

REVISIONS			
LTR	DESCRIPTION	DATE (YR-MO-DA)	APPROVED
A	Changes in accordance with NOR 5962-R320-97.	97-10-22	Monica L. Poelking
B	Update boilerplate to MIL-PRF-38535 and updated appendix A. Editorial changes throughout. - tmh	00-06-14	Monica L. Poelking

REV																				
SHEET																				
REV	B	B	B																	
SHEET	15	16	17																	
REV STATUS	REV			B	B	B	B	B	B	B	B	B	B	B	B	B	B	B	B	
OF SHEETS	SHEET			1	2	3	4	5	6	7	8	9	10	11	12	13	14			
PMIC N/A	PREPARED BY Thanh V. Nguyen						<b>DEFENSE SUPPLY CENTER COLUMBUS COLUMBUS, OHIO 43216</b>													
<b>STANDARD MICROCIRCUIT DRAWING</b>	CHECKED BY Thanh V. Nguyen																			
	APPROVED BY Monica L. Poelking																			
	DRAWING APPROVAL DATE 95-12-19																			
	REVISION LEVEL B																			
THIS DRAWING IS AVAILABLE FOR USE BY ALL DEPARTMENTS AND AGENCIES OF THE DEPARTMENT OF DEFENSE						MICROCIRCUIT, DIGITAL, RADIATION HARDENED ADVANCED CMOS, NONINVERTING OCTAL BIDIRECTIONAL BUS TRANSCEIVER WITH THREE-STATE OUTPUTS, MONOLITHIC SILICON														
																				AMSC N/A
						SHEET 1 OF 17														

1. SCOPE

1.1 Scope. This drawing documents two product assurance class levels consisting of high reliability (device classes Q and M) and space application (device class V). A choice of case outlines and lead finishes are available and are reflected in the Part or Identifying Number (PIN). When available, a choice of Radiation Hardness Assurance (RHA) levels are reflected in the PIN.

1.2 PIN. The PIN is as shown in the following example:

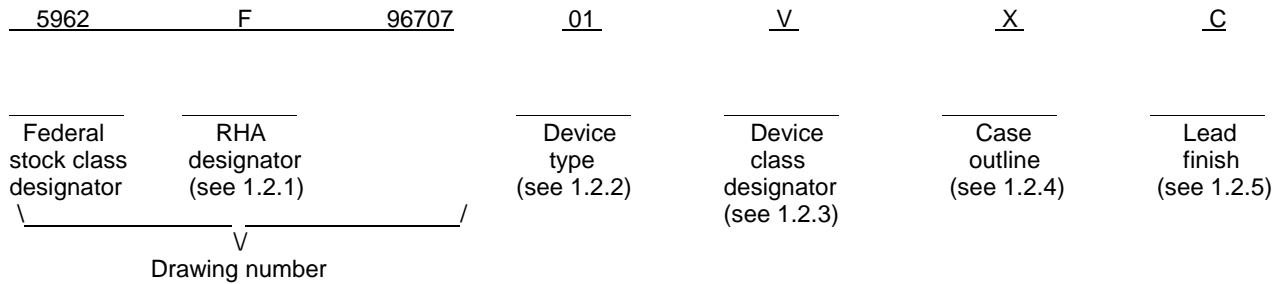

1.2.1 RHA designator. Device classes Q and V RHA marked devices meet the MIL-PRF-38535 specified RHA levels and are marked with the appropriate RHA designator. Device class M RHA marked devices meet the MIL-PRF-38535, appendix A specified RHA levels and are marked with the appropriate RHA designator. A dash (-) indicates a non-RHA device.

1.2.2 Device type(s). The device type(s) identify the circuit function as follows:

<u>Device type</u>	<u>Generic number</u>	<u>Circuit function</u>
01	ACS245	Radiation hardened SOS, advanced CMOS, noninverting octal bidirectional bus transceiver with three-state outputs
02	ACS245A	Radiation hardened SOS, advanced CMOS, noninverting octal bidirectional bus transceiver with three-state outputs
03 <sup>1/</sup>	ACS245-02	Radiation hardened SOS, advanced CMOS, noninverting octal bidirectional bus transceiver with three-state outputs
04 <sup>1/</sup>	ACS245A-02	Radiation hardened SOS, advanced CMOS, noninverting octal bidirectional bus transceiver with three-state outputs

1.2.3 Device class designator. The device class designator is a single letter identifying the product assurance level as follows:

<u>Device class</u>	<u>Device requirements documentation</u>
M	Vendor self-certification to the requirements for MIL-STD-883 compliant, non-JAN class level B microcircuits in accordance with MIL-PRF-38535, appendix A
Q or V	Certification and qualification to MIL-PRF-38535

1.2.4 Case outline(s). The case outline(s) are as designated in MIL-STD-1835 and as follows:

<u>Outline letter</u>	<u>Descriptive designator</u>	<u>Terminals</u>	<u>Package style</u>
R	CDIP2-T20	20	dual-in-line package
X	CDFP4-F20	20	flat package

1.2.5 Lead finish. The lead finish is as specified in MIL-PRF-38535 for device classes Q and V or MIL-PRF-38535, appendix A for device class M.

<sup>1/</sup> Device type -02 is the same as device type -01 except that the device type -02 products are manufactured at an overseas wafer foundry. Device type -02 is used to positively identify, by marketing part number and by brand of the actual device, material that is supplied by an overseas foundry.

<b>STANDARD MICROCIRCUIT DRAWING</b> DEFENSE SUPPLY CENTER COLUMBUS COLUMBUS, OHIO 43216-5000	SIZE <b>A</b>	REVISION LEVEL <b>B</b>	<b>5962-96707</b>  SHEET <b>2</b>
---	------------------	----------------------------	--

1.3 Absolute maximum ratings. 1/ 2/ 3/

Supply voltage range (V <sub>CC</sub> )	-0.5 V dc to +7.0 V dc
DC input voltage range (V <sub>IN</sub> )	-0.5 V dc to V <sub>CC</sub> + 0.5 V dc
DC output voltage range (V <sub>OUT</sub> )	-0.5 V dc to V <sub>CC</sub> + 0.5 V dc
DC input current, any one input (I <sub>IN</sub> )	±10 mA
DC output current, any one output (I <sub>OUT</sub> )	±50 mA
Storage temperature range (T <sub>STG</sub> )	-65°C to +150°C
Lead temperature (soldering, 10 seconds)	+265°C
Thermal resistance, junction-to-case (θ <sub>JC</sub> ):	
Case outline R	24°C/W
Case outline X	28°C/W
Thermal resistance, junction-to-ambient (θ <sub>JA</sub> ):	
Case outline R	72°C/W
Case outline X	107°C/W
Junction temperature (T <sub>J</sub> )	+175°C
Maximum package power dissipation at T <sub>A</sub> = +125°C (P <sub>D</sub> ): 4/	
Case outline R	0.69 W
Case outline X	0.47 W

1.4 Recommended operating conditions. 2/ 3/

Supply voltage range (V <sub>CC</sub> )	+4.5 V dc to +5.5 V dc
Input voltage range (V <sub>IN</sub> )	+0.0 V dc to V <sub>CC</sub>
Output voltage range (V <sub>OUT</sub> )	+0.0 V dc to V <sub>CC</sub>
Maximum low level input voltage (V <sub>IL</sub> )	
Device 01, 03	30% of V <sub>CC</sub>
Device 02, 04	20% of V <sub>CC</sub>
Minimum high level input voltage (V <sub>IH</sub> )	70% of V <sub>CC</sub>
Case operating temperature range (T <sub>C</sub> )	-55°C to +125°C
Maximum input rise and fall time at V <sub>CC</sub> = 4.5 V (t <sub>r</sub> , t <sub>f</sub> )	10 ns/V
Radiation features:	
Total dose	> 3 x 10 <sup>5</sup> Rads (Si)
Single event phenomenon (SEP) effective	
linear energy threshold (LET) no upsets (see 4.4.4.4)	> 100 MeV/(cm <sup>2</sup> /mg) 5/
Dose rate upset (20 ns pulse)	> 1 x 10 <sup>11</sup> Rads (Si)/s 5/
Latch-up	None 5/
Dose rate survivability	> 1 x 10 <sup>12</sup> Rads (Si)/s 5/

2. APPLICABLE DOCUMENTS

2.1 Government specification, standards, and handbooks. The following specification, standards, and handbooks form a part of this drawing to the extent specified herein. Unless otherwise specified, the issues of these documents are those listed in the issue of the Department of Defense Index of Specifications and Standards (DoDISS) and supplement thereto, cited in the solicitation.

SPECIFICATION

DEPARTMENT OF DEFENSE

MIL-PRF-38535 - Integrated Circuits, Manufacturing, General Specification for.

- 1/ Stresses above the absolute maximum rating may cause permanent damage to the device. Extended operation at the maximum levels may degrade performance and affect reliability.
- 2/ Unless otherwise specified, all voltages are referenced to V<sub>SS</sub>.
- 3/ The limits for the parameters specified herein shall apply over the full specified V<sub>CC</sub> range and case temperature range of -55°C to +125°C unless otherwise noted.
- 4/ If device power exceeds package dissipation capability, provide heat sinking or derate linearly (the derating is based on θ<sub>JA</sub>) at the following rate:
 

Case R	13.9 mW/°C
Case X	9.3 mW/°C
- 5/ Guaranteed by design or process but not tested.

<b>STANDARD MICROCIRCUIT DRAWING</b> DEFENSE SUPPLY CENTER COLUMBUS COLUMBUS, OHIO 43216-5000	SIZE <b>A</b>	REVISION LEVEL <b>B</b>	<b>5962-96707</b>  SHEET 3
---	------------------	----------------------------	-------------------------------------

STANDARDS

DEPARTMENT OF DEFENSE

- MIL-STD-883 - Test Method Standard Microcircuits.
- MIL-STD-973 - Configuration Management.
- MIL-STD-1835 - Interface Standard For Microcircuit Case Outlines.

HANDBOOKS

DEPARTMENT OF DEFENSE

- MIL-HDBK-103 - List of Standard Microcircuit Drawings (SMD's).
- MIL-HDBK-780 - Standard Microcircuit Drawings.

(Unless otherwise indicated, copies of the specification, standards, and handbooks are available from the Standardization Document Order Desk, 700 Robbins Avenue, Building 4D, Philadelphia, PA 19111-5094.)

2.2 Order of precedence. In the event of a conflict between the text of this drawing and the references cited herein, the text of this drawing takes precedence. Nothing in this document, however, supersedes applicable laws and regulations unless a specific exemption has been obtained.

3. REQUIREMENTS

3.1 Item requirements. The individual item requirements for device classes Q and V shall be in accordance with MIL-PRF-38535 and as specified herein or as modified in the device manufacturer's Quality Management (QM) plan. The modification in the QM plan shall not affect the form, fit, or function as described herein. The individual item requirements for device class M shall be in accordance with MIL-PRF-38535, appendix A for non-JAN class level B devices and as specified herein.

3.2 Design, construction, and physical dimensions. The design, construction, and physical dimensions shall be as specified in MIL-PRF-38535 and herein for device classes Q and V or MIL-PRF-38535, appendix A and herein for device class M.

3.2.1 Case outlines. The case outlines shall be in accordance with 1.2.4 herein.

3.2.2 Terminal connections. The terminal connections shall be as specified on figure 1.

3.2.3 Truth table. The truth table shall be as specified on figure 2.

3.2.4 Logic diagram. The logic diagram shall be as specified on figure 3.

3.2.5 Switching waveform and test circuit. The switching waveforms and test circuits shall be as specified on figure 4.

3.2.6 Radiation exposure circuit. The radiation test connections shall be as specified in table III herein.

3.3 Electrical performance characteristics and postirradiation parameter limits. Unless otherwise specified herein, the electrical performance characteristics and postirradiation parameter limits are as specified in table I and shall apply over the full case operating temperature range.

3.4 Electrical test requirements. The electrical test requirements shall be the subgroups specified in table II. The electrical tests for each subgroup are defined in table I.

3.5 Marking. The part shall be marked with the PIN listed in 1.2 herein. In addition, the manufacturer's PIN may also be marked as listed in MIL-HDBK-103. For packages where marking of the entire SMD PIN number is not feasible due to space limitations, the manufacturer has the option of not marking the "5962-" on the device. For RHA product using this option, the RHA designator shall still be marked. Marking for device classes Q and V shall be in accordance with MIL-PRF-38535. Marking for device class M shall be in accordance with MIL-PRF-38535, appendix A.

3.5.1 Certification/compliance mark. The certification mark for device classes Q and V shall be a "QML" or "Q" as required in MIL-PRF-38535. The compliance mark for device class M shall be a "C" as required in MIL-PRF-38535, appendix A.

<b>STANDARD MICROCIRCUIT DRAWING</b> DEFENSE SUPPLY CENTER COLUMBUS COLUMBUS, OHIO 43216-5000	SIZE <b>A</b>		<b>5962-96707</b>
		REVISION LEVEL <b>B</b>	SHEET <b>4</b>

3.6 Certificate of compliance. For device classes Q and V, a certificate of compliance shall be required from a QML-38535 listed manufacturer in order to supply to the requirements of this drawing (see 6.6.1 herein). For device class M, a certificate of compliance shall be required from a manufacturer in order to be listed as an approved source of supply in MIL-HDBK-103 (see 6.6.2 herein). The certificate of compliance submitted to DSCC-VA prior to listing as an approved source of supply for this drawing shall affirm that the manufacturer's product meets, for device classes Q and V, the requirements of MIL-PRF-38535 and herein or for device class M, the requirements of MIL-PRF-38535, appendix A and herein.

3.7 Certificate of conformance. A certificate of conformance as required for device classes Q and V in MIL-PRF-38535 or for device class M in MIL-PRF-38535, appendix A shall be provided with each lot of microcircuits delivered to this drawing.

3.8 Notification of change for device class M. For device class M, notification to DSCC-VA of change of product (see 6.2 herein) involving devices acquired to this drawing is required for any change as defined in MIL-STD-973.

3.9 Verification and review for device class M. For device class M, DSCC, DSCC's agent, and the acquiring activity retain the option to review the manufacturer's facility and applicable required documentation. Offshore documentation shall be made available onshore at the option of the reviewer.

3.10 Microcircuit group assignment for device class M. Device class M devices covered by this drawing shall be in microcircuit group number 37 (see MIL-PRF-38535, appendix A).

4. QUALITY ASSURANCE PROVISIONS

4.1 Sampling and inspection. For device classes Q and V, sampling and inspection procedures shall be in accordance with MIL-PRF-38535 or as modified in the device manufacturer's Quality Management (QM) plan. The modification in the QM plan shall not affect the form, fit, or function as described herein. For device class M, sampling and inspection procedures shall be in accordance with MIL-PRF-38535, appendix A.

4.2 Screening. For device classes Q and V, screening shall be in accordance with MIL-PRF-38535, and shall be conducted on all devices prior to qualification and technology conformance inspection. For device class M, screening shall be in accordance with method 5004 of MIL-STD-883, and shall be conducted on all devices prior to quality conformance inspection.

4.2.1 Additional criteria for device class M.

a. Burn-in test, method 1015 of MIL-STD-883.

(1) Test condition A, B, C or D. The test circuit shall be maintained by the manufacturer under document revision level control and shall be made available to the preparing or acquiring activity upon request. The test circuit shall specify the inputs, outputs, biases, and power dissipation, as applicable, in accordance with the intent specified in test method 1015.

(2) T<sub>A</sub> = +125°C, minimum.

b. Interim and final electrical test parameters shall be as specified in table IIA herein.

4.2.2 Additional criteria for device classes Q and V.

a. The burn-in test duration, test condition and test temperature, or approved alternatives shall be as specified in the device manufacturer's QM plan in accordance with MIL-PRF-38535. The burn-in test circuit shall be maintained under document revision level control of the device manufacturer's Technology Review Board (TRB) in accordance with MIL-PRF-38535 and shall be made available to the acquiring or preparing activity upon request. The test circuit shall specify the inputs, outputs, biases, and power dissipation, as applicable, in accordance with the intent specified in test method 1015 of MIL-STD-883.

b. Interim and final electrical test parameters shall be as specified in table IIA herein.

c. Additional screening for device class V beyond the requirements of device class Q shall be as specified in MIL-PRF-38535, appendix B.

4.3 Qualification inspection for device classes Q and V. Qualification inspection for device classes Q and V shall be in accordance with MIL-PRF-38535. Inspections to be performed shall be those specified in MIL-PRF-38535 and herein for groups A, B, C, D, and E inspections (see 4.4.1 through 4.4.4).

<b>STANDARD MICROCIRCUIT DRAWING</b> DEFENSE SUPPLY CENTER COLUMBUS COLUMBUS, OHIO 43216-5000	SIZE <b>A</b>		<b>5962-96707</b>
		REVISION LEVEL <b>B</b>	SHEET <b>5</b>

TABLE I. Electrical performance characteristics.

Test	Symbol	Test conditions <u>1/</u> -55°C ≤ T <sub>C</sub> ≤ +125°C unless otherwise specified	Device type	V <sub>CC</sub>	Group A subgroups	Limits <u>2/</u>		Unit		
						Min	Max			
High level output voltage	V <sub>OH</sub>	For all inputs affecting output under test V <sub>IN</sub> = 4.5 V or 0.0 V For all other inputs V <sub>IN</sub> = V <sub>CC</sub> or GND I <sub>OH</sub> = -50 μA	01, 03	4.5 V	1, 2, 3	4.40		V		
			M, D, L, R, F <u>3/</u>						01, 03	1
		For all inputs affecting output under test V <sub>IN</sub> = 5.5 V or 0.0 V For all other inputs V <sub>IN</sub> = V <sub>CC</sub> or GND I <sub>OH</sub> = -50 μA	01, 03	5.5 V	1, 2, 3	5.40			V	
			M, D, L, R, F <u>3/</u>							01, 03
		For all inputs affecting output under test V <sub>IN</sub> = 3.15 V or 0.9 V For all other inputs V <sub>IN</sub> = V <sub>CC</sub> or GND I <sub>OH</sub> = -50 μA	02, 04	4.5 V	1, 2, 3	4.40				V
For all inputs affecting output under test V <sub>IN</sub> = 3.85 V or 1.1 V For all other inputs V <sub>IN</sub> = V <sub>CC</sub> or GND I <sub>OH</sub> = -50 μA	02, 04	5.5 V	1, 2, 3	5.40		V				
							M, D, L, R, F <u>3/</u>	02, 04		
Low level output voltage	V <sub>OL</sub>	For all inputs affecting output under test V <sub>IN</sub> = 4.5 V or 0.0 V For all other inputs V <sub>IN</sub> = V <sub>CC</sub> or GND I <sub>OL</sub> = 50 μA	01, 03	4.5 V	1, 2, 3			0.1	V	
			M, D, L, R, F <u>3/</u>							
		For all inputs affecting output under test V <sub>IN</sub> = 5.5 V or 0.0 V For all other inputs V <sub>IN</sub> = V <sub>CC</sub> or GND I <sub>OL</sub> = 50 μA	01, 03	5.5 V	1, 2, 3			0.1		V

See footnotes at end of table.

<b>STANDARD MICROCIRCUIT DRAWING</b> DEFENSE SUPPLY CENTER COLUMBUS COLUMBUS, OHIO 43216-5000	SIZE <b>A</b>		<b>5962-96707</b>
		REVISION LEVEL <b>B</b>	SHEET <b>6</b>

TABLE I. Electrical performance characteristics - Continued.

Test	Symbol	Test conditions <u>1/</u> -55°C ≤ T <sub>C</sub> ≤ +125°C unless otherwise specified	Device type	V <sub>CC</sub>	Group A subgroups	Limits <u>2/</u>		Unit		
						Min	Max			
Low level output voltage	V <sub>OL</sub>	For all inputs affecting output under test V <sub>IN</sub> = 3.15 V or 0.9 V For all other inputs V <sub>IN</sub> = V <sub>CC</sub> or GND I <sub>OL</sub> = 50 μA		4.5 V	1, 2, 3		0.1	V		
			M, D, L, R, F <u>3/</u>		02, 04	1	0.1			
		For all inputs affecting output under test V <sub>IN</sub> = 3.85 V or 1.1 V For all other inputs V <sub>IN</sub> = V <sub>CC</sub> or GND I <sub>OL</sub> = 50 μA		5.5 V	1, 2, 3		0.1			
			M, D, L, R, F <u>3/</u>		02, 04	1	0.1			
		Positive-going threshold	V <sub>T+</sub>			4.5 V	1, 2, 3	2.15	3.15	V
					M, D, L, R, F <u>3/</u>		02, 04	1	2.15	
Negative-going threshold	V <sub>T-</sub>			4.5 V	1, 2, 3	0.90	1.90	V		
			M, D, L, R, F <u>3/</u>		02, 04	1	0.90		1.90	
Hysteresis (V <sub>T+</sub> - V <sub>T-</sub> )	V <sub>H</sub>			4.5 V	1, 2, 3	0.80	2.25	V		
			M, D, L, R, F <u>3/</u>		02, 04	1	0.80		2.25	
Input current high	I <sub>IH</sub>	For input under test, V <sub>IN</sub> = 5.5 V For all other inputs V <sub>IN</sub> = V <sub>CC</sub> or GND		5.5 V	1		+0.5	μA		
					2, 3		+1.0			
			M, D, L, R, F <u>3/</u>		All	1			+1.0	
Input current low	I <sub>IL</sub>	For input under test, V <sub>IN</sub> = GND For all other inputs V <sub>IN</sub> = V <sub>CC</sub> or GND		5.5 V	1		-0.5	μA		
					2, 3		-1.0			
			M, D, L, R, F <u>3/</u>		All	1			-1.0	
Output current high (Source)	I <sub>OH</sub> <u>4/</u>	For all inputs affecting output under test, V <sub>IN</sub> = 4.5 V or 0.0 V For all other inputs V <sub>IN</sub> = V <sub>CC</sub> or GND V <sub>OUT</sub> = 4.1 V		4.5 V	1	-16.0		mA		
			M, D, L, R, F <u>3/</u>		01, 03	2, 3	-12.0			
		For all inputs affecting output under test, V <sub>IN</sub> = 4.5 V or 0.0 V For all other inputs V <sub>IN</sub> = V <sub>CC</sub> or GND V <sub>OUT</sub> = 4.1 V		4.5 V	1	-12.0		mA		
			M, D, L, R, F <u>3/</u>		02, 04	2, 3	-8.0			
				4.5 V	1	-12.0		mA		
			M, D, L, R, F <u>3/</u>		02, 04	1	-8.0			

See footnotes at end of table.

<b>STANDARD MICROCIRCUIT DRAWING</b> DEFENSE SUPPLY CENTER COLUMBUS COLUMBUS, OHIO 43216-5000	SIZE <b>A</b>		<b>5962-96707</b>
		REVISION LEVEL <b>B</b>	SHEET <b>7</b>

TABLE I. Electrical performance characteristics - Continued.

Test	Symbol	Test conditions <u>1/</u> -55°C ≤ T <sub>C</sub> ≤ +125°C unless otherwise specified	Device type	V <sub>CC</sub>	Group A subgroups	Limits <u>2/</u>		Unit					
						Min	Max						
Output current low (Sink)	I <sub>OL</sub> <u>4/</u>	For all inputs affecting output under test, V <sub>IN</sub> = 4.5 V or 0.0 V For all other inputs V <sub>IN</sub> = V <sub>CC</sub> or GND V <sub>OUT</sub> = 0.4 V	01, 03	4.5 V	1	16.0		mA					
									M, D, L, R, F <u>3/</u>	01, 03	1	12.0	
		For all inputs affecting output under test, V <sub>IN</sub> = 4.5 V or 0.0 V For all other inputs V <sub>IN</sub> = V <sub>CC</sub> or GND V <sub>OUT</sub> = 0.4 V	02, 04	4.5 V	1	12.0		mA					
									M, D, L, R, F <u>3/</u>	02, 04	1	8.0	
Three-state output leakage current high	I <sub>OZH</sub>	OE = 5.5 V For all other inputs V <sub>IN</sub> = 0.0 V or 5.5 V V <sub>OUT</sub> = 5.5 V	All	5.5 V	1		+1.0	μA					
									M, D, L, R, F <u>3/</u>	All	1		+35.0
Three-state output leakage current low	I <sub>OZL</sub>	OE = 5.5 V For all other inputs V <sub>IN</sub> = 0.0 V or 5.5 V V <sub>OUT</sub> = 0.0 V	All	5.5 V	1		-1.0	μA					
									M, D, L, R, F <u>3/</u>	All	1		-35.0
Quiescent supply current	I <sub>CC</sub>	V <sub>IN</sub> = V <sub>CC</sub> or GND	All	5.5 V	1		20.0	μA					
									M, D, L, R, F <u>3/</u>	All	1		400.0
Input capacitance	C <sub>IN</sub>	V <sub>IH</sub> = 5.0 V, V <sub>IL</sub> = 0.0 V f = 1 MHz, see 4.4.1c	01, 03	5.0 V	4		15	pF					
									I/O capacitance	C <sub>I/O</sub>	01, 03	5.0 V	4
Power dissipation capacitance	C <sub>PD</sub> <u>5/</u>	01, 03	5.0 V	4		75	pF						
								02, 04	5.0 V	4		75	
01, 03	5.0 V	4		53									
					02, 04	5.0 V	4		60				
Functional test	<u>6/</u>	V <sub>IH</sub> = 3.15 V, V <sub>IL</sub> = 1.35 V See 4.4.1b	01, 03	4.5 V						7, 8	L	H	
					M, D, L, R, F <u>3/</u>	01, 03	7	L	H				
		V <sub>IH</sub> = 3.15 V, V <sub>IL</sub> = 0.9 V See 4.4.1b	02, 04	4.5 V	7, 8	L	H						
									M, D, L, R, F <u>3/</u>	02, 04	7	L	H

See footnotes at end of table.

<b>STANDARD MICROCIRCUIT DRAWING</b> DEFENSE SUPPLY CENTER COLUMBUS COLUMBUS, OHIO 43216-5000	SIZE <b>A</b>		<b>5962-96707</b>
		REVISION LEVEL <b>B</b>	SHEET <b>8</b>



TABLE I. Electrical performance characteristics - Continued.

Test	Symbol	Test conditions 1/ -55°C ≤ T <sub>C</sub> ≤ +125°C unless otherwise specified	Device type	V <sub>CC</sub>	Group A subgroups	Limits 2/		Unit	
						Min	Max		
Propagation delay time, An to Bn or Bn to An	t <sub>PLH</sub> Z/	C <sub>L</sub> = 50 pF R <sub>L</sub> = 500Ω See figure 4	01, 03	4.5 V	9	1.0	8.5	ns	
						10, 11	1.0		10.0
		M, D, L, R, F 3/	01, 03		9	1.0	10.0		
		C <sub>L</sub> = 50 pF R <sub>L</sub> = 500Ω See figure 4	02, 04		9	2.0	12.0		ns
	10, 11			2.0		12.0			
	M, D, L, R, F 3/	02, 04	9	2.0	12.0				
	Propagation delay time, output enable, OE to An or Bn	t <sub>PHL</sub> Z/	C <sub>L</sub> = 50 pF R <sub>L</sub> = 500Ω See figure 4	01, 03	4.5 V	9	1.0	8.0	ns
							10, 11	1.0	
M, D, L, R, F 3/			01, 03	9		1.0	9.0		
C <sub>L</sub> = 50 pF R <sub>L</sub> = 500Ω See figure 4			02, 04	9		2.0	12.0	ns	
		10, 11			2.0	12.0			
M, D, L, R, F 3/		02, 04	9	2.0	12.0				
Propagation delay time, output disable, OE to An or Bn		t <sub>PZH</sub> Z/	C <sub>L</sub> = 50 pF R <sub>L</sub> = 500Ω See figure 4	01, 03	4.5 V	9	2.0	12.5	ns
							10, 11	2.0	
	M, D, L, R, F 3/		01, 03	9		2.0	15.0		
	C <sub>L</sub> = 50 pF R <sub>L</sub> = 500Ω See figure 4		02, 04	9		2.0	20.0	ns	
		10, 11			2.0	20.0			
	M, D, L, R, F 3/	02, 04	9	2.0	20.0				
	Propagation delay time, output disable, OE to An or Bn	t <sub>PZL</sub> Z/	C <sub>L</sub> = 50 pF R <sub>L</sub> = 500Ω See figure 4	01, 03	4.5V	9	2.0	11.5	ns
							10, 11	2.0	
M, D, L, R, F 3/			01, 03	9		2.0	15.0		
C <sub>L</sub> = 50 pF R <sub>L</sub> = 500Ω See figure 4			02, 04	9		2.0	20.0	ns	
		10, 11			2.0	20.0			
M, D, L, R, F 3/		02, 04	9	2.0	20.0				
Propagation delay time, output enable, OE to An or Bn		t <sub>PHZ</sub> Z/	C <sub>L</sub> = 50 pF R <sub>L</sub> = 500Ω See figure 4	01, 03	4.5 V	9	2.0	14.5	ns
							10, 11	2.0	
	M, D, L, R, F 3/		01, 03	9		2.0	15.0		
	C <sub>L</sub> = 50 pF R <sub>L</sub> = 500Ω See figure 4		02, 04	9		2.0	20.0	ns	
		10, 11			2.0	20.0			
	M, D, L, R, F 3/	02, 04	9	2.0	20.0				

See footnotes at end of table.

<b>STANDARD MICROCIRCUIT DRAWING</b> DEFENSE SUPPLY CENTER COLUMBUS COLUMBUS, OHIO 43216-5000	SIZE <b>A</b>		<b>5962-96707</b>
		REVISION LEVEL <b>B</b>	SHEET 9

TABLE I. Electrical performance characteristics - Continued.

Test	Symbol	Test conditions <u>1/</u> -55°C ≤ T <sub>C</sub> ≤ +125°C unless otherwise specified	Device type	V <sub>CC</sub>	Group A subgroups	Limits <u>2/</u>		Unit	
						Min	Max		
Propagation delay time, output disable, OE to An or Bn	t <sub>PLZ</sub> <u>7/</u>	C <sub>L</sub> = 50 pF R <sub>L</sub> = 500Ω See figure 4	01, 03	4.5 V	9	2.0	13.5	ns	
						M, D, L, R, F <u>3/</u>	01, 03		9
			C <sub>L</sub> = 50 pF R <sub>L</sub> = 500Ω See figure 4		02, 04				9
		M, D, L, R, F <u>3/</u>				02, 04	10, 11		2.0
					9		2.0		20.0
		Output transition time	t <sub>FHL</sub> , t <sub>TLH</sub> <u>7/</u>		C <sub>L</sub> = 50 pF R <sub>L</sub> = 500Ω See figure 4	All	4.5 V		9
M, D, L, R, F <u>3/</u>	All			10, 11				1.0	
				9		1.0		5.0	

- 1/ Each input/output, as applicable, shall be tested at the specified temperature, for the specified limits, to the tests in table I herein. Output terminals not designated shall be high level logic, low level logic, or open, except for the I<sub>CC</sub> test, the output terminals shall be open. When performing the I<sub>CC</sub> test, the current meter shall be placed in the circuit such that all current flows through the meter.
- 2/ For negative and positive voltage and current values, the sign designates the potential difference in reference to GND and the direction of current flow respectively; and the absolute value of the magnitude, not the sign, is relative to the minimum and maximum limits, as applicable, listed herein.
- 3/ Devices supplied to this drawing meet all levels M, D, L, R, and F of irradiation. However, this device is only tested at the "F" level. Pre and post irradiation values are identical unless otherwise specified in table I. When performing post irradiation electrical measurements for any RHA level, T<sub>A</sub> = +25°C.
- 4/ Force/Measure functions may be interchanged.
- 5/ Power dissipation capacitance (C<sub>PD</sub>) determines both the power consumption (P<sub>D</sub>) and current consumption (I<sub>S</sub>). Where  

$$P_D = (C_{PD} + C_L) (V_{CC} \times V_{CC})f + (I_{CC} \times V_{CC})$$

$$I_S = (C_{PD} + C_L) V_{CC}f + I_{CC}$$
 f is the frequency of the input signal.
- 6/ The test vectors used to verify the truth table shall, at a minimum, test all functions of each input and output. All possible input to output logic patterns per function shall be guaranteed, if not tested, to the truth table in figure 2 herein. For V<sub>OUT</sub> measurements, L ≤ 0.5 V and H ≥ 4.0 V.
- 7/ AC limits at V<sub>CC</sub> = 5.5 V are equal to the limits at V<sub>CC</sub> = 4.5 V. For propagation delay tests, all paths must be tested.

<b>STANDARD MICROCIRCUIT DRAWING</b> DEFENSE SUPPLY CENTER COLUMBUS COLUMBUS, OHIO 43216-5000	SIZE <b>A</b>		<b>5962-96707</b>
		REVISION LEVEL <b>B</b>	SHEET 10

Device type	All		
Case outlines	R and X		
Terminal number	Terminal symbol	Terminal number	Terminal symbol
1	DIR	11	B7
2	A0	12	B6
3	A1	13	B5
4	A2	14	B4
5	A3	15	B3
6	A4	16	B2
7	A5	17	B1
8	A6	18	B0
9	A7	19	$\overline{\text{OE}}$
10	GND	20	V <sub>CC</sub>

FIGURE 1. Terminal connections.

Inputs		Operation
$\overline{\text{OE}}$	DIR	
L	L	B data to A bus
L	H	A data to B bus
H	X	Isolation

H = High voltage level  
L = Low voltage level  
X = Immaterial

FIGURE 2. Truth table.

<b>STANDARD  MICROCIRCUIT DRAWING</b> DEFENSE SUPPLY CENTER COLUMBUS COLUMBUS, OHIO 43216-5000	<b>SIZE  A</b>		<b>5962-96707</b>
		REVISION LEVEL <b>B</b>	SHEET 11

1 OF 8

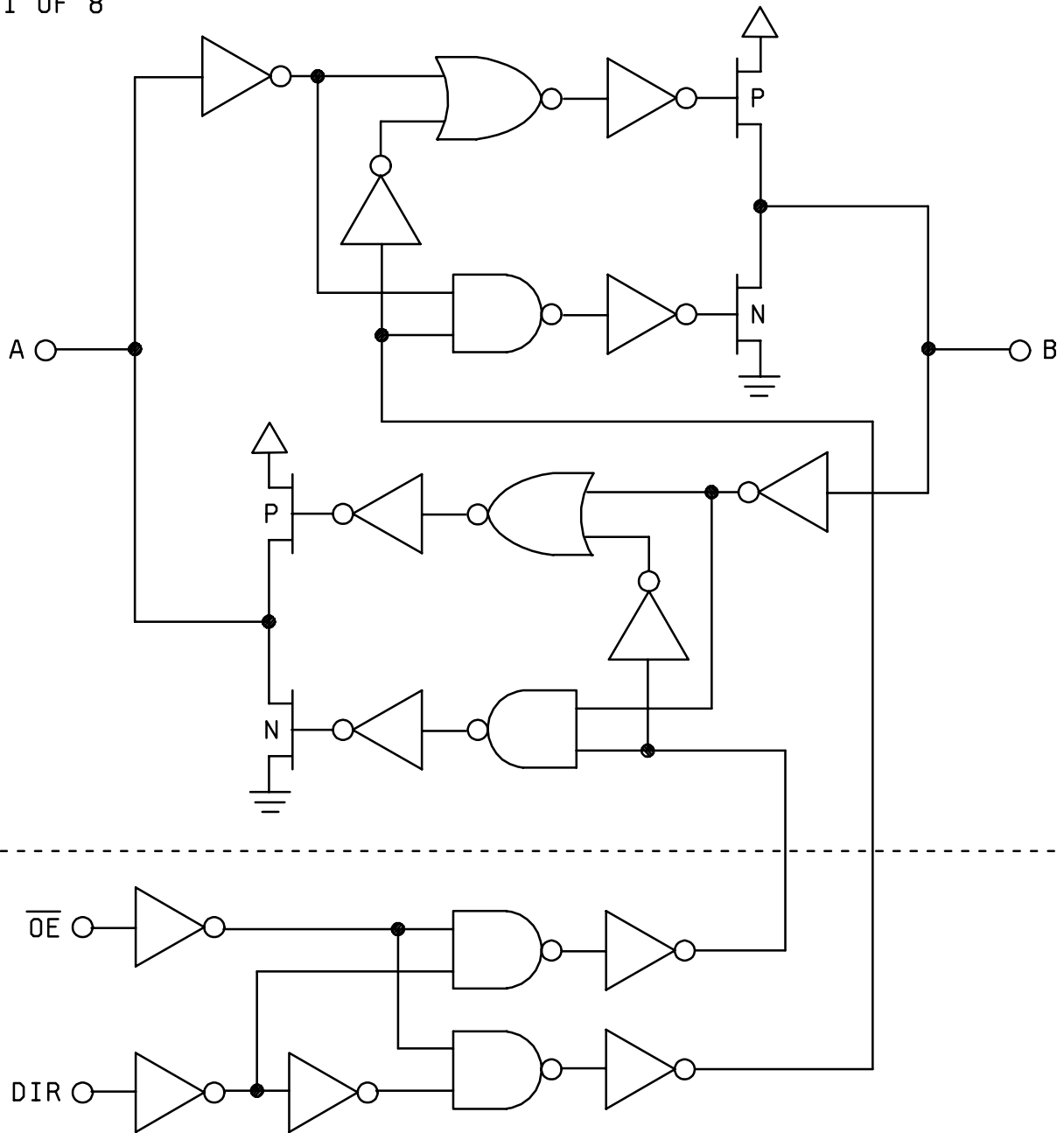

FIGURE 3. Logic diagram.

**STANDARD  
MICROCIRCUIT DRAWING**  
DEFENSE SUPPLY CENTER COLUMBUS  
COLUMBUS, OHIO 43216-5000

SIZE  
**A**

REVISION LEVEL  
**B**

**5962-96707**

SHEET

12

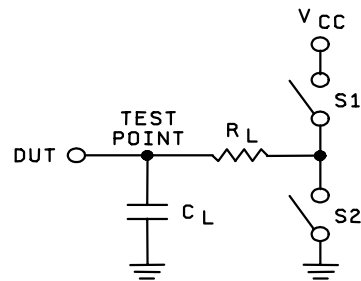
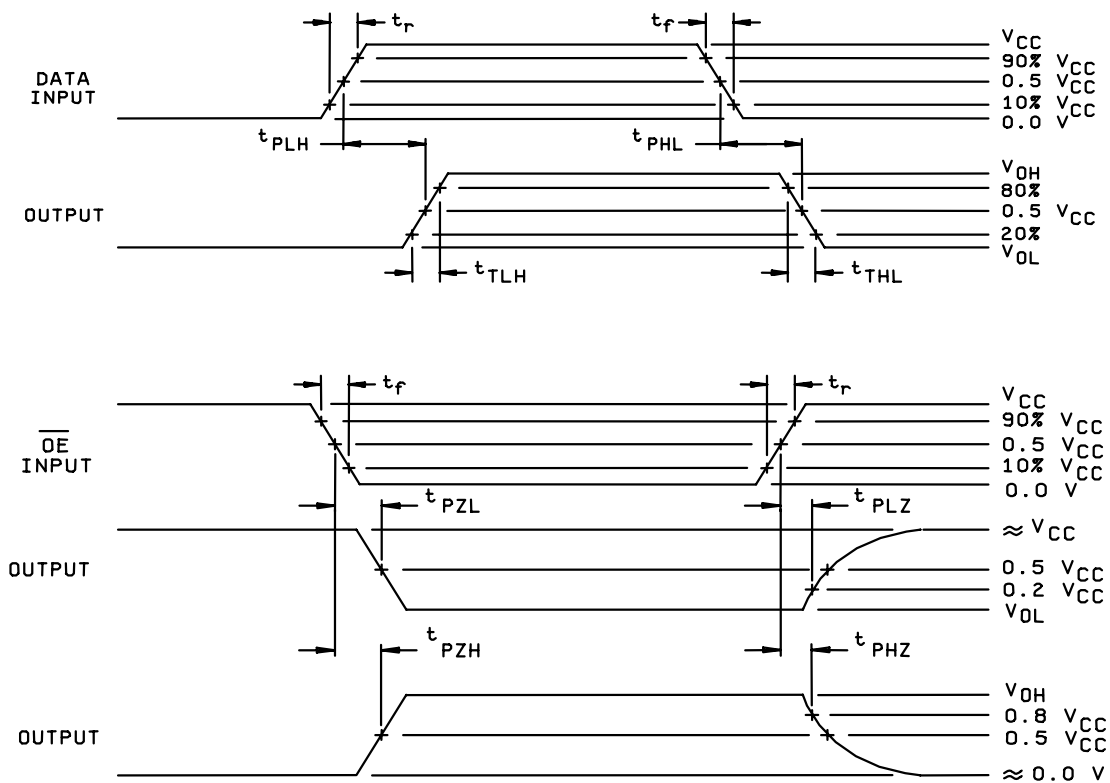

**NOTES:**

1. When measuring  $t_{PZL}$  and  $t_{PLZ}$ , S1 is closed and S2 is open.
2. When measuring  $t_{PLH}$ ,  $t_{PHL}$ ,  $t_{PZH}$ , and  $t_{PHZ}$ , S1 is open and S2 is closed.
3.  $C_L = 50$  pF minimum or equivalent (includes test jig and probe capacitance).
4.  $R_L = 500\Omega$  or equivalent.
5. Input signal from pulse generator:  $V_{IN} = 0.0$  V to  $V_{CC}$ ;  $PRR \leq 10$  MHz;  $t_r \leq 3.0$  ns;  $t_f \leq 3.0$  ns;  $t_r$  and  $t_f$  shall be measured from 10%  $V_{CC}$  to 90%  $V_{CC}$  and from 90%  $V_{CC}$  to 10%  $V_{CC}$ , respectively.

FIGURE 4. Switching waveforms and test circuit.

<b>STANDARD MICROCIRCUIT DRAWING</b> DEFENSE SUPPLY CENTER COLUMBUS COLUMBUS, OHIO 43216-5000	SIZE <b>A</b>		<b>5962-96707</b>
		REVISION LEVEL <b>B</b>	SHEET 13

4.4 Conformance inspection. Technology conformance inspection for classes Q and V shall be in accordance with MIL-PRF-38535 including groups A, B, C, D, and E inspections and as specified herein except where option 2 of MIL-PRF-38535 permits alternate in-line control testing. Quality conformance inspection for device class M shall be in accordance with MIL-PRF-38535, appendix A and as specified herein. Inspections to be performed for device class M shall be those specified in method 5005 of MIL-STD-883 and herein for groups A, B, C, D, and E inspections (see 4.4.1 through 4.4.4).

4.4.1 Group A inspection.

- a. Tests shall be as specified in table IIA herein.
- b. For device class M, subgroups 7 and 8 tests shall be sufficient to verify the truth table. For device classes Q and V, subgroups 7 and 8 shall include verifying the functionality of the device; these tests shall have been fault graded in accordance with MIL-STD-883, test method 5012 (see 1.5 herein).
- c. Subgroup 4 ( $C_{IN}$ ,  $C_{I/O}$  and  $C_{PD}$  measurement) shall be measured only for the initial qualification and after process or design changes which may affect capacitance.  $C_{IN}$ ,  $C_{I/O}$  shall be measured between the designated terminal and GND at a frequency of 1 MHz. For  $C_{IN}$ ,  $C_{I/O}$  and  $C_{PD}$  the tests shall be sufficient to validate the limits defined in table I herein.

TABLE IIA. Electrical test requirements.

Test requirements	Subgroups (in accordance with MIL-STD-883, method 5005, table I)	Subgroups (in accordance with MIL-PRF-38535, table III)	
	Device class M	Device class Q	Device class V
Interim electrical parameters (see 4.2)	1, 7, 9	1, 7, 9	1, 7, 9
Final electrical parameters (see 4.2)	1, 2, 3, 7, 8, 9, 10, 11 <u>1/</u>	1, 2, 3, 7, 8, 9, 10, 11 <u>1/</u>	1, 2, 3, 7, 8, 9, 10, 11 <u>2/ 3/</u>
Group A test requirements (see 4.4)	1, 2, 3, 4, 5, 6, 7, 8, 9, 10, 11	1, 2, 3, 4, 5, 6, 7, 8, 9, 10, 11	1, 2, 3, 4, 7, 8, 9, 10, 11
Group C end-point electrical parameters (see 4.4)	1, 2, 3, 7, 8, 9, 10, 11	1, 2, 3, 7, 8, 9, 10, 11	1, 2, 3, 7, 8, 9, 10, 11 <u>3/</u>
Group D end-point electrical parameters (see 4.4)	1, 7, 9	1, 7, 9	1, 7, 9
Group E end-point electrical parameters (see 4.4)	1, 7, 9	1, 7, 9	1, 7, 9

1/ PDA applies to subgroup 1 and 7.

2/ PDA applies to subgroups 1, 7, 9 and deltas.

3/ Delta limits as specified in table IIB shall be required where specified, and the delta limits shall be completed with reference to the zero hour electrical parameters (see Table I)

TABLE IIB. Burn-in and operating life test, Delta parameters (+25°C).

Parameters <u>1/</u>	Delta limits
$I_{CC}$	$\pm 4 \mu A$
$I_{OL}/I_{OH}$	$\pm 15\%$
$I_{OZL}/I_{OZH}$	$\pm 200 nA$

1/ These parameters shall be recorded before and after the required burn-in and life test to determine delta limits.

4.4.2 Group C inspection. The group C inspection end-point electrical parameters shall be as specified in table II herein.

<b>STANDARD MICROCIRCUIT DRAWING</b> DEFENSE SUPPLY CENTER COLUMBUS COLUMBUS, OHIO 43216-5000	SIZE <b>A</b>		<b>5962-96707</b>
		REVISION LEVEL <b>B</b>	SHEET 14

4.4.2.1 Additional criteria for device class M. Steady-state life test conditions, method 1005 of MIL-STD-883:

- a. Test condition A, B, C or D. The test circuit shall be maintained by the manufacturer under document revision level control and shall be made available to the preparing or acquiring activity upon request. The test circuit shall specify the inputs, outputs, biases, and power dissipation, as applicable, in accordance with the intent specified in test method 1005 of MIL-STD-883.
- b.  $T_A = +125^{\circ}\text{C}$ , minimum.
- c. Test duration: 1,000 hours, except as permitted by method 1005 of MIL-STD-883.

4.4.2.2 Additional criteria for device classes Q and V. The steady-state life test duration, test condition and test temperature, or approved alternatives shall be as specified in the device manufacturer's QM plan in accordance with MIL-PRF-38535. The test circuit shall be maintained under document revision level control by the device manufacturer's TRB in accordance with MIL-PRF-38535 and shall be made available to the acquiring or preparing activity upon request. The test circuit shall specify the inputs, outputs, biases, and power dissipation, as applicable, in accordance with the intent specified in test method 1005 of MIL-STD-883.

4.4.3 Group D inspection. The group D inspection end-point electrical parameters shall be as specified in table II herein.

4.4.4 Group E inspection. Group E inspection is required only for parts intended to be marked as radiation hardness assured (see 3.5 herein). RHA levels for device classes M, Q and V shall be as specified in MIL-PRF-38535. End-point electrical parameters shall be as specified in table IIA herein.

4.4.4.1 Total dose irradiation testing. Total dose irradiation testing shall be performed in accordance with MIL-STD-883 method 1019 and as specified herein.

4.4.4.1.1 Accelerated aging test. Accelerated aging tests shall be performed on all devices requiring a RHA level greater than 5k rads(Si). The post-anneal end-point electrical parameter limits shall be as specified in table I herein and shall be the pre-irradiation end-point electrical parameter limit at  $+25^{\circ}\text{C} \pm 5^{\circ}\text{C}$ . Testing shall be performed at initial qualification and after any design or process changes which may affect the RHA response of the device.

4.4.4.2 Dose rate induced latchup testing. Dose rate induced latchup testing shall be performed in accordance with test method 1020 of MIL-STD-883 and as specified herein (see 1.4 herein). Tests shall be performed on devices, SEC, or approved test structures at technology qualification and after any design or process changes which may effect the RHA capability of the process.

4.4.4.3 Dose rate upset testing. Dose rate upset testing shall be performed in accordance with test method 1021 of MIL-STD-883 and herein (see 1.4 herein).

- a. Transient dose rate upset testing shall be performed at initial qualification and after any design or process changes which may effect the RHA performance of the devices. Test 10 devices with 0 defects unless otherwise specified.
- b. Transient dose rate upset testing for class Q and V devices shall be performed as specified by a TRB approved radiation hardness assurance plan and MIL-PRF-38535.

4.4.4.4 Single event phenomena (SEP). SEP testing shall be required on class V devices (see 1.4 herein). SEP testing shall be performed on a technology process on the Standard Evaluation Circuit (SEC) or alternate SEP test vehicle as approved by the qualifying activity at initial qualification and after any design or process changes which may affect the upset or latchup characteristics. The recommended test conditions for SEP are as follows:

- a. The ion beam angle of incidence shall be between normal to the die surface and  $60^{\circ}$  to the normal, inclusive (i.e.  $0^{\circ} \leq \text{angle} \leq 60^{\circ}$ ). No shadowing of the ion beam due to fixturing or package related effects is allowed.
- b. The fluence shall be  $\geq 100$  errors or  $\geq 10^6$  ions/cm<sup>2</sup>.
- c. The flux shall be between  $10^2$  and  $10^5$  ions/cm<sup>2</sup>/s. The cross-section shall be verified to be flux independent by measuring the cross-section at two flux rates which differ by at least an order of magnitude.
- d. The particle range shall be  $\geq 20$  microns in silicon.
- e. The test temperature shall be  $+25^{\circ}\text{C}$  and the maximum rated operating temperature  $\pm 10^{\circ}\text{C}$ .

<b>STANDARD MICROCIRCUIT DRAWING</b> DEFENSE SUPPLY CENTER COLUMBUS COLUMBUS, OHIO 43216-5000	SIZE <b>A</b>		<b>5962-96707</b>
		REVISION LEVEL <b>B</b>	SHEET 15

- f. Bias conditions shall be defined by the manufacturer for latchup measurements.
- g. Test four devices with zero failures.

4.5 Methods of inspection. Methods of inspection shall be as specified as follows:

4.5.1 Voltage and current. Unless otherwise specified, all voltages given are referenced to the microcircuit GND terminal. Currents given are conventional current and positive when flowing into the referenced terminal.

Table III. Irradiation test connections. 1/

Open	Ground	V <sub>CC</sub> = 5 V ± 0.5 V
-	10	1, 2, 3, 4, 5, 6, 7, 8, 9, 11, 12, 13, 14, 15, 16, 17, 18, 19, 20

1/ Each pin except V<sub>DD</sub> and GND will have a series resistor of 47KΩ ±5%, for irradiation testing.

5. PACKAGING

5.1 Packaging requirements. The requirements for packaging shall be in accordance with MIL-PRF-38535 for device classes Q and V or MIL-PRF-38535, appendix A for device class M.

6. NOTES

6.1 Intended use. Microcircuits conforming to this drawing are intended for use for Government microcircuit applications (original equipment), design applications, and logistics purposes.

6.1.1 Replaceability. Microcircuits covered by this drawing will replace the same generic device covered by a contractor prepared specification or drawing.

6.1.2 Substitutability. Device class Q devices will replace device class M devices.

6.2 Configuration control of SMD's. All proposed changes to existing SMD's will be coordinated with the users of record for the individual documents. This coordination will be accomplished in accordance with MIL-STD-973 using DD Form 1692, Engineering Change Proposal.

6.3 Record of users. Military and industrial users should inform Defense Supply Center Columbus when a system application requires configuration control and which SMD's are applicable to that system. DSCC will maintain a record of users and this list will be used for coordination and distribution of changes to the drawings. Users of drawings covering microelectronic devices (FSC 5962) should contact DSCC-VA, telephone (614) 692-0525.

6.4 Comments. Comments on this drawing should be directed to DSCC-VA , Columbus, Ohio 43216-5000, or telephone (614) 692-0674.

6.5 Abbreviations, symbols, and definitions. The abbreviations, symbols, and definitions used herein are defined in MIL-PRF-38535 and MIL-HDBK-1331.

- GND ..... Ground zero voltage potential.
- I<sub>CC</sub>..... Quiescent supply current.
- I<sub>IL</sub> ..... Input current low.
- I<sub>IH</sub> ..... Input current high.
- T<sub>C</sub>..... Case temperature.
- T<sub>A</sub>..... Ambient temperature.
- V<sub>CC</sub>..... Positive supply voltage.
- C<sub>IN</sub> ..... Input terminal-to-GND capacitance.
- C<sub>OUT</sub>..... Output terminal-to-GND capacitance.
- C<sub>PD</sub>..... Power dissipation capacitance.

<b>STANDARD MICROCIRCUIT DRAWING</b> DEFENSE SUPPLY CENTER COLUMBUS COLUMBUS, OHIO 43216-5000	SIZE <b>A</b>		<b>5962-96707</b>
		REVISION LEVEL <b>B</b>	SHEET 16



6.6 Sources of supply.

6.6.1 Sources of supply for device classes Q and V. Sources of supply for device classes Q and V are listed in QML-38535. The vendors listed in QML-38535 have submitted a certificate of compliance (see 3.6 herein) to DSCC-VA and have agreed to this drawing.

6.6.2 Approved sources of supply for device class M. Approved sources of supply for class M are listed in MIL-HDBK-103. The vendors listed in MIL-HDBK-103 have agreed to this drawing and a certificate of compliance (see 3.6 herein) has been submitted to and accepted by DSCC-VA.

6.7 Additional information. A copy of the following additional data shall be maintained and available from the device manufacturer:

- a. RHA upset levels.
- b. Test conditions (SEP).
- c. Number of upsets (SEP).
- d. Number of transients (SEP).
- e. Occurrence of latchup (SEP).

<b>STANDARD MICROCIRCUIT DRAWING</b> DEFENSE SUPPLY CENTER COLUMBUS COLUMBUS, OHIO 43216-5000	SIZE <b>A</b>		<b>5962-96707</b>
		REVISION LEVEL <b>B</b>	SHEET  17

STANDARD MICROCIRCUIT DRAWING BULLETIN

DATE: 9x-

Approved sources of supply for SMD 5962-96707 are listed below for immediate acquisition information only and shall be added to MIL-HDBK-103 and QML-38535 during the next revision. MIL-HDBK-103 and QML-38535 will be revised to include the addition or deletion of sources. The vendors listed below have agreed to this drawing and a certificate of compliance has been submitted to and accepted by DSCC-VA. This bulletin is superseded by the next dated revision of MIL-HDBK-103 and QML-38535.

Standard microcircuit drawing PIN <u>1/</u>	Vendor CAGE number	Vendor similar PIN <u>2/</u>
5962F9670701VRC	34371	ACS245DMSR
5962F9670701VXC	34371	ACS245KMSR
5962F9670702VRC	34371	ACS245ADMSR
5962F9670702VXC	34371	ACS245AKMSR
5962F9670703VRC	34371	ACS245DMSR-02
5962F9670703VXC	34371	ACS245KMSR-02
5962F9670704VRC	34371	ACS245ADMSR-02
5962F9670704VXC	34371	ACS245AKMSR-02

1/ The lead finish shown for each PIN representing a hermetic package is the most readily available from the manufacturer listed for that part. If the desired lead finish is not listed contact the vendor to determine its availability.

2/ Caution. Do not use this number for item acquisition. Items acquired to this number may not satisfy the performance requirements of this drawing.

Vendor CAGE number

34371

Vendor name and address

Intersil Corporation  
PO Box 883  
Melbourne, FL 32902-0883

The information contained herein is disseminated for convenience only and the Government assumes no liability whatsoever for any inaccuracies in the information bulletin.