

NOTICE OF REVISION (NOR)		1. DATE (YYMMDD) 98-07-31	Form Approved OMB No. 0704-0188
THIS REVISION DESCRIBED BELOW HAS BEEN AUTHORIZED FOR THE DOCUMENT LISTED.			
Public reporting burden for this collection is estimated to average 2 hours per response, including the time for reviewing instructions, searching existing data sources, gathering and maintaining the data needed, and completing and reviewing the collection of information. Send comments regarding this burden estimate or any other aspect of this collection of information, including suggestions for reducing this burden, to Department of Defense, Washington Headquarters Services, Directorate for Information Operations and Reports, 1215 Jefferson Davis Highway, Suite 1204, Arlington, VA 22202-4302, and to the Office of Management and Budget, Paperwork Reduction Project (0704-0188), Washington, DC 20503. PLEASE DO NOT RETURN YOUR COMPLETED FORM TO EITHER OF THESE ADDRESSES. RETURN COMPLETED FORM TO THE GOVERNMENT ISSUING CONTRACTING OFFICER FOR THE CONTRACT/ PROCURING ACTIVITY NUMBER LISTED IN ITEM 2 OF THIS FORM.			2. PROCURING ACTIVITY NO.
			3. DODAAC
4. ORIGINATOR	b. ADDRESS (<i>Street, City, State, Zip Code</i>) Defense Supply Center, Columbus 3990 East Broad Street Columbus, OH 43216-5000	5. CAGE CODE 67268	6. NOR NO. 5962-R142-98
a. TYPED NAME (<i>First, Middle Initial, Last</i>)		7. CAGE CODE 67268	8. DOCUMENT NO. 5962-95788
9. TITLE OF DOCUMENT MICROCIRCUIT, DIGITAL, RADIATION HARDENED, HIGH SPEED CMOS, SYNCHRONOUS 4-BIT BINARY UP/DOWN COUNTER, MONOLITHIC SILICON		10. REVISION LETTER	
		a. CURRENT -	b. NEW A
11. ECP NO. No users listed.			
12. CONFIGURATION ITEM (OR SYSTEM) TO WHICH ECP APPLIES All			
13. DESCRIPTION OF REVISION			
<p>Sheet 1: Revisions ltr column; add "A". Revisions description column; add "Changes in accordance with NOR 5962-R142-98". Revisions date column; add "98-07-31". Revision level block; add "A". Rev status of sheets; for sheets 1, 4, and 18 through 24, add "A".</p> <p>Sheet 4: Add new paragraph which states; "3.1.1 <u>Microcircuit die</u>. For the requirements for microcircuit die, see appendix A to this document." Revision level block; add "A".</p> <p>Sheets 18 through 24: Add attached appendix A.</p> <p style="text-align: center;">CONTINUED ON NEXT SHEETS</p>			
14. THIS SECTION FOR GOVERNMENT USE ONLY			
a. (<i>X one</i>)	<input checked="" type="checkbox"/>	(1) Existing document supplemented by the NOR may be used in manufacture.	
	<input type="checkbox"/>	(2) Revised document must be received before manufacturer may incorporate this change.	
	<input type="checkbox"/>	(3) Custodian of master document shall make above revision and furnish revised document.	
b. ACTIVITY AUTHORIZED TO APPROVE CHANGE FOR GOVERNMENT DSCC-VAC		c. TYPED NAME (<i>First, Middle Initial, Last</i>) MONICA L. POELKING	
d. TITLE CHIEF, CUSTOM MICROELECTRONICS TEAM	e. SIGNATURE MONICA L. POELKING		f. DATE SIGNED (YYMMDD) 98-07-31
15a. ACTIVITY ACCOMPLISHING REVISION DSCC-VAC	b. REVISION COMPLETED (<i>Signature</i>) CHARLES F. SAFFLE, JR.		c. DATE SIGNED (YYMMDD) 98-07-31

APPENDIX A
APPENDIX A FORMS A PART OF SMD 5962-95788

Document No: 5962-95788
Revision: A
NOR No: 5962-R142-98
Sheet: 2 of 8

10. SCOPE

10.1 Scope. This appendix establishes minimum requirements for microcircuit die to be supplied under the Qualified Manufacturers List (QML) Program. QML microcircuit die meeting the requirements of MIL-PRF-38535 and the manufacturers approved QM plan for use in monolithic microcircuits, multichip modules (MCMs), hybrids, electronic modules, or devices using chip and wire designs in accordance with MIL-PRF-38534 are specified herein. Two product assurance classes consisting of military high reliability (device class Q) and space application (device Class V) are reflected in the Part or Identification Number (PIN). When available a choice of Radiation Hardness Assurance (RHA) levels are reflected in the PIN.

10.2 PIN. The PIN shall be as shown in the following example:

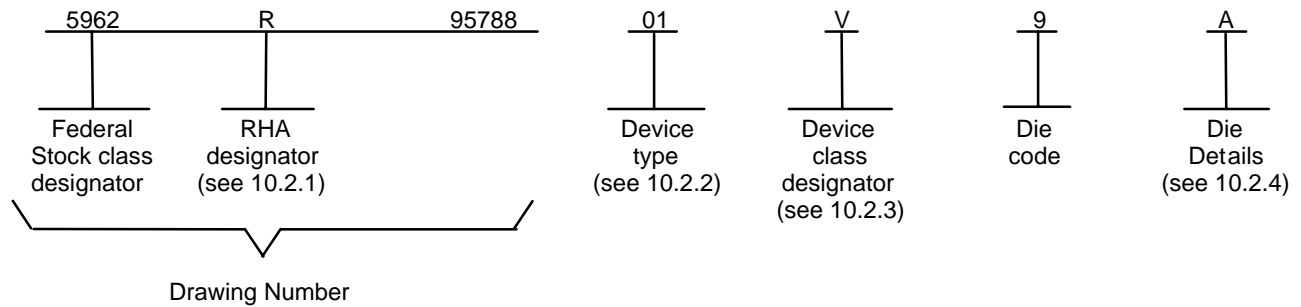

10.2.1 RHA designator. Device classes Q and V RHA identified die shall meet the MIL-PRF-38535 specified RHA levels. A dash (-) indicates a non-RHA die.

10.2.2 Device type(s). The device type(s) shall identify the circuit function as follows:

<u>Device type</u>	<u>Generic number</u>	<u>Circuit function</u>
01	HCS193	Radiation Hardened, SOS, high speed CMOS, synchronous 4-bit binary up/down counter.

10.2.3 Device class designator.

<u>Device class</u>	<u>Device requirements documentation</u>
Q or V	Certification and qualification to the die requirements of MIL-PRF-38535.

STANDARD MICROCIRCUIT DRAWING DEFENSE SUPPLY CENTER COLUMBUS COLUMBUS, OHIO 43216-5000	SIZE A		5962-95788
		REVISION LEVEL A	SHEET 18

APPENDIX A
APPENDIX A FORMS A PART OF SMD 5962-95788

Document No: 5962-95788
Revision: A
NOR No: 5962-R142-98
Sheet: 3 of 8

10.2.4 Die Details. The die details designation shall be a unique letter which designates the die's physical dimensions, bonding pad location(s) and related electrical function(s), interface materials, and other assembly related information, for each product and variant supplied to this appendix.

10.2.4.1 Die Physical dimensions.

<u>Die Types</u>	<u>Figure number</u>
01	A-1

10.2.4.2 Die Bonding pad locations and Electrical functions.

<u>Die Types</u>	<u>Figure number</u>
01	A-1

10.2.4.3 Interface Materials.

<u>Die Types</u>	<u>Figure number</u>
01	A-1

10.2.4.4 Assembly related information.

01	A-1
----	-----

10.3 Absolute maximum ratings. See paragraph 1.3 within the body of this drawing for details.

10.4 Recommended operating conditions. See paragraph 1.4 within the body of this drawing for details.

20. APPLICABLE DOCUMENTS

20.1 Government specifications, standards, bulletin, and handbooks. Unless otherwise specified, the following specifications, standards, bulletin, and handbook of the issue listed in that issue of the Department of Defense Index of Specifications and Standards specified in the solicitation, form a part of this drawing to the extent specified herein.

STANDARD MICROCIRCUIT DRAWING DEFENSE SUPPLY CENTER COLUMBUS COLUMBUS, OHIO 43216-5000	SIZE A		5962-95788
		REVISION LEVEL A	SHEET 19

APPENDIX A
APPENDIX A FORMS A PART OF SMD 5962-95788

Document No: 5962-95788
Revision: A
NOR No: 5962-R142-98
Sheet: 4 of 8

SPECIFICATION

DEPARTMENT OF DEFENSE

MIL-PRF-38535 - Integrated Circuits, Manufacturing, General Specification for.

STANDARDS

DEPARTMENT OF DEFENSE

MIL-STD-883 - Test Methods and Procedures for Microelectronics.

HANDBOOK

DEPARTMENT OF DEFENSE

MIL-HDBK-103 - List of Standardized Military Drawings (SMD's).

(Copies of the specification, standards, bulletin, and handbook required by manufacturers in connection with specific acquisition functions should be obtained from the contracting activity or as directed by the contracting activity).

20.2 Order of precedence. In the event of a conflict between the text of this drawing and the references cited herein, the text of this drawing shall take precedence.

30. REQUIREMENTS

30.1 Item Requirements. The individual item requirements for device classes Q and V shall be in accordance with MIL-PRF-38535 and as specified herein or as modified in the device manufacturer's Quality Management (QM) plan. The modification in the QM plan shall not effect the form, fit or function as described herein.

30.2 Design, construction and physical dimensions. The design, construction and physical dimensions shall be as specified in MIL-PRF-38535 and the manufacturer's QM plan, for device classes Q and V and herein.

30.2.1 Die Physical dimensions. The die physical dimensions shall be as specified in 10.2.4.1 and on figure A-1.

30.2.2 Die bonding pad locations and electrical functions. The die bonding pad locations and electrical functions shall be as specified in 10.2.4.2 and on figure A-1.

30.2.3 Interface materials. The interface materials for the die shall be as specified in 10.2.4.3 and on figure A-1.

30.2.4 Assembly related information. The assembly related information shall be as specified in 10.2.4.4 and figure A-1.

30.2.5 Truth table. The truth table shall be as defined within paragraph 3.2.3 of the body of this document.

30.2.6 Radiation exposure circuit. The radiation exposure circuit shall be as defined within paragraph 3.2.6 of the body of this document.

STANDARD MICROCIRCUIT DRAWING DEFENSE SUPPLY CENTER COLUMBUS COLUMBUS, OHIO 43216-5000	SIZE A		5962-95788
		REVISION LEVEL A	SHEET 20

APPENDIX A
APPENDIX A FORMS A PART OF SMD 5962-95788

Document No: 5962-95788
Revision: A
NOR No: 5962-R142-98
Sheet: 5 of 8

30.3 Electrical performance characteristics and post-irradiation parameter limits. Unless otherwise specified herein, the electrical performance characteristics and post-irradiation parameter limits are as specified in table I of the body of this document.

30.4 Electrical test requirements. The wafer probe test requirements shall include functional and parametric testing sufficient to make the packaged die capable of meeting the electrical performance requirements in table I.

30.5 Marking. As a minimum, each unique lot of die, loaded in single or multiple stack of carriers, for shipment to a customer, shall be identified with the wafer lot number, the certification mark, the manufacturer's identification and the PIN listed in 10.2 herein. The certification mark shall be a "QML" or "Q" as required by MIL-PRF-38535.

30.6 Certification of compliance. For device classes Q and V, a certificate of compliance shall be required from a QML-38535 listed manufacturer in order to supply to the requirements of this drawing (see 60.4 herein). The certificate of compliance submitted to DSCC-VA prior to listing as an approved source of supply for this appendix shall affirm that the manufacturer's product meets, for device classes Q and V, the requirements of MIL-PRF-38535 and the requirements herein.

30.7 Certificate of conformance. A certificate of conformance as required for device classes Q and V in MIL-PRF-38535 shall be provided with each lot of microcircuit die delivered to this drawing.

40. QUALITY ASSURANCE PROVISIONS

40.1 Sampling and inspection. For device classes Q and V, die sampling and inspection procedures shall be in accordance with MIL-PRF-38535 or as modified in the device manufacturer's Quality Management (QM) plan. The modifications in the QM plan shall not effect the form, fit or function as described herein.

40.2 Screening. For device classes Q and V, screening shall be in accordance with MIL-PRF-38535, and as defined in the manufacturer's QM plan. As a minimum it shall consist of:

- a) Wafer Lot acceptance for Class V product using the criteria defined within MIL-STD-883 TM 5007.
- b) 100% wafer probe (see paragraph 30.4).
- c) 100% internal visual inspection to the applicable class Q or V criteria defined within MIL-STD-883 TM2010 or the alternate procedures allowed within MIL-STD-883 TM5004.

STANDARD MICROCIRCUIT DRAWING DEFENSE SUPPLY CENTER COLUMBUS COLUMBUS, OHIO 43216-5000	SIZE A		5962-95788
		REVISION LEVEL A	SHEET 21

APPENDIX A
APPENDIX A FORMS A PART OF SMD 5962-95788

Document No: 5962-95788
Revision: A
NOR No: 5962-R142-98
Sheet: 6 of 8

40.3 Conformance inspection.

40.3.1 Group E inspection. Group E inspection is required only for parts intended to be identified as radiation assured (see 30.5 herein). RHA levels for device classes Q and V shall be as specified in MIL-PRF-38535. End point electrical testing of packaged die shall be as specified in table IIA herein. Group E tests and conditions are as specified within paragraphs 4.4.4.1, 4.4.4.1.1, 4.4.4.2, 4.4.4.3, and 4.4.4.4.

50. DIE CARRIER

50.1 Die carrier requirements. The requirements for the die carrier shall be accordance with the manufacturer's QM plan or as specified in the purchase order by the acquiring activity. The die carrier shall provide adequate physical, mechanical and electrostatic protection.

60. NOTES

60.1 Intended use. Microcircuit die conforming to this drawing are intended for use in microcircuits built in accordance with MIL-PRF-38535 or MIL-PRF-38534 for government microcircuit applications (original equipment), design applications and logistics purposes.

60.2 Comments. Comments on this appendix should be directed to DSCC-VA, Columbus, Ohio, 43216-5000 or telephone (614)-692-0674.

60.3 Abbreviations, symbols and definitions. The abbreviations, symbols, and definitions used herein are defined with MIL-PRF-38535 and MIL-HDBK-1331.

60.4 Sources of Supply for device classes Q and V. Sources of supply for device classes Q and V are listed in QML-38535. The vendors listed within QML-38535 have submitted a certificate of compliance (see 30.6 herein) to DSCC-VA and have agreed to this drawing.

STANDARD MICROCIRCUIT DRAWING DEFENSE SUPPLY CENTER COLUMBUS COLUMBUS, OHIO 43216-5000	SIZE A		5962-95788
		REVISION LEVEL A	SHEET 22

APPENDIX A
 APPENDIX A FORMS A PART OF SMD 5962-95788

Document No: 5962-95788
 Revision: A
 NOR No: 5962-R142-98
 Sheet: 7 of 8

FIGURE A-1

o DIE PHYSICAL DIMENSIONS

Die Size: 2190 x 2650 microns.
 Die Thickness: 21 +/-2 mils.

o DIE BONDING PAD LOCATIONS AND ELECTRICAL FUNCTIONS

The following metallization diagram supplies the locations and electrical functions of the bonding pads. The internal metallization layout and alphanumeric information contained within this diagram may or may not represent the actual circuit defined by this SMD.

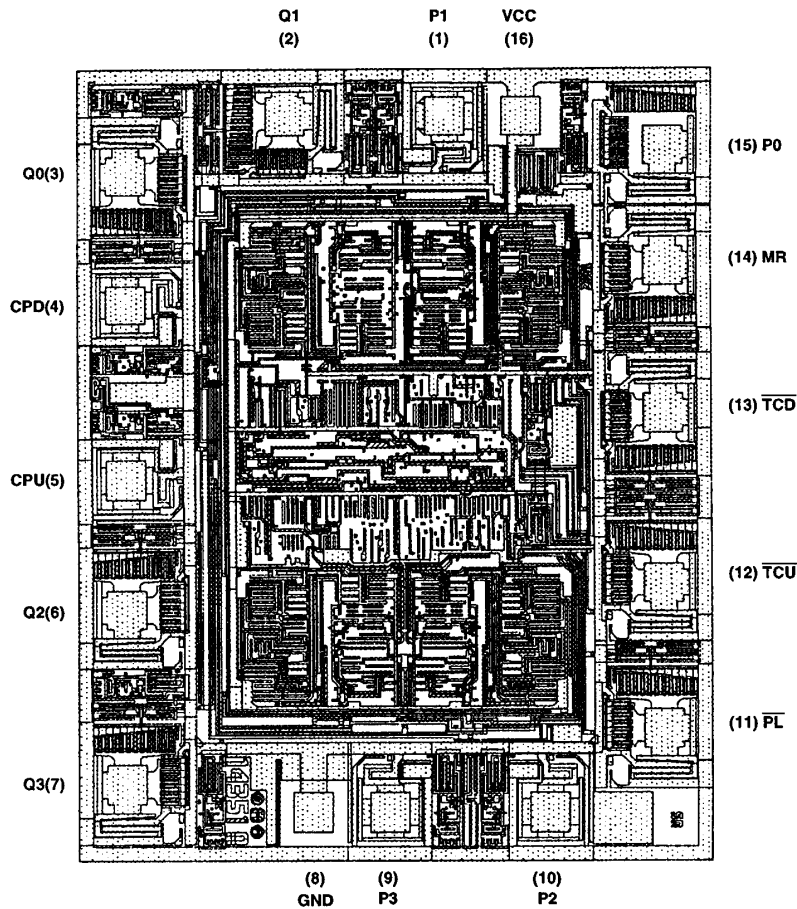

NOTE: Pad numbers reflect terminal numbers when placed in Case Outlines E, X (see Figure 1).

STANDARD MICROCIRCUIT DRAWING DEFENSE SUPPLY CENTER COLUMBUS COLUMBUS, OHIO 43216-5000	SIZE A		5962-95788
		REVISION LEVEL A	SHEET 23

APPENDIX A
APPENDIX A FORMS A PART OF SMD 5962-95788

Document No: 5962-95788
Revision: A
NOR No: 5962-R142-98
Sheet: 8 of 8

o INTERFACE MATERIALS

Top Metallization: SiAl 11.0kA +/- 1kA
Backside Metallization None
Glassivation
Type: SiO2
Thickness 13kA +/- 2.6kA
Substrate: Silicon on Sapphire (SOS)

o ASSEMBLY RELATED INFORMATION

Substrate Potential: Insulator.
Special assembly instructions: Bond pad #16 (VCC) first.

STANDARD MICROCIRCUIT DRAWING DEFENSE SUPPLY CENTER COLUMBUS COLUMBUS, OHIO 43216-5000	SIZE A		5962-95788
		REVISION LEVEL A	SHEET 24

STANDARD MICROCIRCUIT DRAWING BULLETIN

DATE: 98-07-31

Approved sources of supply for SMD 5962-95788 are listed below for immediate acquisition information only and shall be added to MIL-HDBK-103 and QML-38535 during the next revision. MIL-HDBK-103 and QML-38535 will be revised to include the addition or deletion of sources. The vendors listed below have agreed to this drawing and a certificate of compliance has been submitted to and accepted by DSCC-VA. This bulletin is superseded by the next dated revision of MIL-HDBK-103 and QML-38535.

Standard microcircuit drawing PIN	Vendor CAGE number	Vendor similar PIN <u>1/</u>
5962R9578801V9A	34371	HCS193HMSR

1/ Caution. Do not use this number for item acquisition. Items acquired to this number may not satisfy the performance requirements of this drawing.

Vendor CAGE number

34371

Vendor name and address

Harris Semiconductor
P.O. Box 883
Melbourne, FL 32902-0883

The information contained herein is disseminated for convenience only and the Government assumes no liability whatsoever for any inaccuracies in the information bulletin.

REVISIONS

LTR	DESCRIPTION	DATE (YR-MO-DA)	APPROVED

REV																			
SHEET																			
REV																			
SHEET	15	16	17																

REV STATUS OF SHEETS	REV																		
	SHEET	1	2	3	4	5	6	7	8	9	10	11	12	13	14				

PMIC N/A	PREPARED BY Rick C. Officer	DEFENSE ELECTRONICS SUPPLY CENTER DAYTON, OHIO 45444
STANDARD MICROCIRCUIT DRAWING THIS DRAWING IS AVAILABLE FOR USE BY ALL DEPARTMENTS AND AGENCIES OF THE DEPARTMENT OF DEFENSE AMSC N/A	CHECKED BY Thanh V. Nguyen	
	APPROVED BY Monica Poelking	
	DRAWING APPROVAL DATE 95-11-08	
	REVISION LEVEL	
MICROCIRCUIT, DIGITAL, RADIATION HARDENED, HIGH SPEED CMOS, SYNCHRONOUS 4-BIT BINARY UP/DOWN COUNTER, MONOLITHIC SILICON		
SIZE A	CAGE CODE 67268	5962-95788
SHEET 1 OF 17		

1. SCOPE

1.1 Scope. This drawing forms a part of a one part - one part number documentation system (see 6.6 herein). Two product assurance classes consisting of military high reliability (device classes Q and M) and space application (device class V), and a choice of case outlines and lead finishes are available and are reflected in the Part or Identifying Number (PIN). Device class M microcircuits represent non-JAN class B microcircuits in accordance with 1.2.1 of MIL-STD-883, "Provisions for the use of MIL-STD-883 in conjunction with compliant non-JAN devices". When available, a choice of Radiation Hardness Assurance (RHA) levels are reflected in the PIN.

1.2 PIN. The PIN shall be as shown in the following example:

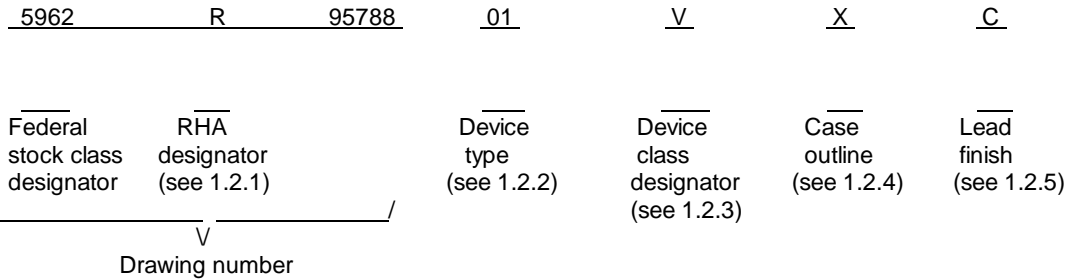

1.2.1 RHA designator. Device class M RHA marked devices shall meet the MIL-I-38535 appendix A specified RHA levels and shall be marked with the appropriate RHA designator. Device classes Q and V RHA marked devices shall meet the MIL-I-38535 specified RHA levels and shall be marked with the appropriate RHA designator. A dash (-) indicates a non-RHA device.

1.2.2 Device type(s). The device type(s) shall identify the circuit function as follows:

<u>Device type</u>	<u>Generic number</u>	<u>Circuit function</u>
01	HCS193	Radiation hardened, SOS, high speed CMOS, synchronous 4-bit binary up/down counter

1.2.3 Device class designator. The device class designator shall be a single letter identifying the product assurance level as follows:

<u>Device class</u>	<u>Device requirements documentation</u>
M	Vendor self-certification to the requirements for non-JAN class B microcircuits in accordance with 1.2.1 of MIL-STD-883
Q or V	Certification and qualification to MIL-I-38535

1.2.4 Case outline(s). The case outline(s) shall be as designated in MIL-STD-1835 and as follows:

<u>Outline letter</u>	<u>Descriptive designator</u>	<u>Terminals</u>	<u>Package style</u>
E	CDIP2-T16	16	Dual-in-line
X	CDFP4-F16	16	Flat pack

1.2.5 Lead finish. The lead finish shall be as specified in MIL-STD-883 (see 3.1 herein) for class M or MIL-I-38535 for classes Q and V. Finish letter "X" shall not be marked on the microcircuit or its packaging. The "X" designation is for use in specifications when lead finishes A, B, and C are considered acceptable and interchangeable without preference.

STANDARD MICROCIRCUIT DRAWING DEFENSE ELECTRONICS SUPPLY CENTER DAYTON, OHIO 45444	SIZE A	5962-95788
	REVISION LEVEL	SHEET 2

1.3 Absolute maximum ratings. 1/ 2/ 3/

Supply voltage range (V_{CC})	-0.5 V dc to +7.0 V dc
DC input voltage range (V_{IN})	-0.5 V dc to $V_{CC} + 0.5$ V dc
DC output voltage range (V_{OUT})	-0.5 V dc to $V_{CC} + 0.5$ V dc
DC input current, any one input (I_{IN})	± 10 mA
DC output current, any one output (I_{OUT})	± 25 mA
Storage temperature range (T_{STG})	-65° C to +150° C
Lead temperature (soldering, 10 seconds)	+265° C
Thermal resistance, junction-to-case (Θ_{JC}):	
Case outline E	24° C/W
Case outline X	29° C/W
Thermal resistance, junction-to-ambient (Θ_{JA}):	
Case outline E	73° C/W
Case outline X	114° C/W
Junction temperature (T_J)	+175° C
Maximum package power dissipation at $T_A = +125^\circ\text{C}$ (P_D): 4/	
Case outline E	0.68 W
Case outline X	0.44 W

1.4 Recommended operating conditions. 2/ 3/

Supply voltage range (V_{CC})	+4.5 V dc to +5.5 V dc
Input voltage range (V_{IN})	+0.0 V dc to V_{CC}
Output voltage range (V_{OUT})	+0.0 V dc to V_{CC}
Maximum low level input voltage (V_{IL})	30% of V_{CC}
Minimum high level input voltage (V_{IH})	70% of V_{CC}
Case operating temperature range (T_C)	-55° C to +125° C
Maximum input rise and fall time at $V_{CC} = 4.5$ V (t_r, t_f)	500 ns
Radiation features:	
Total dose	> 2×10^5 Rads (Si)
Single event phenomenon (SEP) effective	
linear energy threshold (LET) no upsets (see 4.4.4.4)	> 100 MeV/(cm ² /mg) 5/
Dose rate upset (20 ns pulse)	> 1×10^{10} Rads (Si)/s 5/
Latch-up	None 5/
Dose rate survivability	> 1×10^{12} Rads (Si)/s 5/

2. APPLICABLE DOCUMENTS

2.1 Government specification, standards, bulletin, and handbook. Unless otherwise specified, the following specification, standards, bulletin, and handbook of the issue listed in that issue of the Department of Defense Index of Specifications and Standards specified in the solicitation, form a part of this drawing to the extent specified herein.

SPECIFICATION

MILITARY

MIL-I-38535 - Integrated Circuits, Manufacturing, General Specification for.

- 1/ Stresses above the absolute maximum rating may cause permanent damage to the device. Extended operation at the maximum levels may degrade performance and affect reliability.
- 2/ Unless otherwise noted, all voltages are referenced to GND.
- 3/ The limits for the parameters specified herein shall apply over the full specified V_{CC} range and case temperature range of -55° C to +125° C unless otherwise noted.
- 4/ If device power exceeds package dissipation capability, provide heat sinking or derate linearly (the derating is based on Θ_{JA}) at the following rate:

Case outline E	13.7 mW/° C
Case outline X	8.8 mW/° C
- 5/ Guaranteed by design or process but not tested.

STANDARD MICROCIRCUIT DRAWING DEFENSE ELECTRONICS SUPPLY CENTER DAYTON, OHIO 45444	SIZE A		5962-95788
		REVISION LEVEL	SHEET 3

STANDARDS

MILITARY

- MIL-STD-883 - Test Methods and Procedures for Microelectronics.
- MIL-STD-973 - Configuration Management.
- MIL-STD-1835 - Microcircuit Case Outlines.

BULLETIN

MILITARY

- MIL-BUL-103 - List of Standard Microcircuit Drawings (SMD's).

HANDBOOK

MILITARY

- MIL-HDBK-780 - Standardized Military Drawings.

(Copies of the specification, standards, bulletin, and handbook required by manufacturers in connection with specific acquisition functions should be obtained from the contracting activity or as directed by the contracting activity.)

2.2 Order of precedence. In the event of a conflict between the text of this drawing and the references cited herein, the text of this drawing shall take precedence.

3. REQUIREMENTS

3.1 Item requirements. The individual item requirements for device class M shall be in accordance with 1.2.1 of MIL-STD-883, "Provisions for the use of MIL-STD-883 in conjunction with compliant non-JAN devices" and as specified herein. The individual item requirements for device classes Q and V shall be in accordance with MIL-I-38535 and as specified herein or as modified in the device manufacturer's Quality Management (QM) plan. The modification in the QM plan shall not affect the form, fit, or function as described herein.

3.2 Design, construction, and physical dimensions. The design, construction, and physical dimensions shall be as specified in MIL-STD-883 (see 3.1 herein) for device class M and MIL-I-38535 for device classes Q and V and herein.

3.2.1 Case outlines. The case outlines shall be in accordance with 1.2.4 herein.

3.2.2 Terminal connections. The terminal connections shall be as specified on figure 1.

3.2.3 Truth table. The truth table shall be as specified on figure 2.

3.2.4 Logic diagram. The logic diagram shall be as specified on figure 3.

3.2.5 Switching waveforms and test circuit. The switching waveforms and test circuit shall be as specified on figure 4.

3.2.6 Irradiation test connections. The irradiation test connections shall be as specified in table III.

3.3 Electrical performance characteristics and postirradiation parameter limits. Unless otherwise specified herein, the electrical performance characteristics and postirradiation parameter limits are as specified in table I and shall apply over the full case operating temperature range.

3.4 Electrical test requirements. The electrical test requirements shall be the subgroups specified in table IIA. The electrical tests for each subgroup are defined in table I.

3.5 Marking. The part shall be marked with the PIN listed in 1.2 herein. Marking for device class M shall be in accordance with MIL-STD-883 (see 3.1 herein). In addition, the manufacturer's PIN may also be marked as listed in MIL-BUL-103. Marking for device classes Q and V shall be in accordance with MIL-I-38535.

3.5.1 Certification/compliance mark. The compliance mark for device class M shall be a "C" as required in MIL-STD-883 (see 3.1 herein). The certification mark for device classes Q and V shall be a "QML" or "Q" as required in MIL-I-38535.

STANDARD MICROCIRCUIT DRAWING DEFENSE ELECTRONICS SUPPLY CENTER DAYTON, OHIO 45444	SIZE A		5962-95788
		REVISION LEVEL	SHEET 4

TABLE I. Electrical performance characteristics.

Test	Symbol	Test conditions ^{1/} -55°C ≤ T _C ≤ +125°C unless otherwise specified	Device type	V _{CC}	Group A subgroups	Limits ^{2/}		Unit			
						Min	Max				
High level output voltage	V _{OH}	For all inputs affecting output under test V _{IN} = 3.15 V or 1.35 V For all other inputs V _{IN} = V _{CC} or GND I _{OH} = -50 μA	All	4.5 V	1, 2, 3	4.40		V			
					M, D, L, R <u>3/</u>	All	1		4.40		
		For all inputs affecting output under test V _{IN} = 3.85 V or 1.65 V For all other inputs V _{IN} = V _{CC} or GND I _{OH} = -50 μA	All	5.5 V	1, 2, 3	5.40					
					M, D, L, R <u>3/</u>	All	1		5.40		
		Low level output voltage	V _{OL}	For all inputs affecting output under test V _{IN} = 3.15 V or 1.35 V For all other inputs V _{IN} = V _{CC} or GND I _{OL} = 50 μA	All	4.5 V	1, 2, 3			0.1	V
							M, D, L, R <u>3/</u>		All	1	
For all inputs affecting output under test V _{IN} = 3.85 V or 1.65 V For all other inputs V _{IN} = V _{CC} or GND I _{OL} = 50 μA	All			5.5 V	1, 2, 3		0.1				
					M, D, L, R <u>3/</u>	All	1		0.1		
Input current high	I _{IH}			For input under test, V _{IN} = 5.5 V For all other inputs V _{IN} = V _{CC} or GND	All	5.5 V	1		+0.5	μA	
							2, 3		+5.0		
		M, D, L, R <u>3/</u>	All				1		+5.0		
Input current low	I _{IL}	For input under test, V _{IN} = GND For all other inputs V _{IN} = V _{CC} or GND	All	5.5 V	1		-0.5	μA			
					2, 3		-5.0				
					M, D, L, R <u>3/</u>	All	1			-5.0	

See footnotes at end of table.

STANDARD MICROCIRCUIT DRAWING DEFENSE ELECTRONICS SUPPLY CENTER DAYTON, OHIO 45444	SIZE A		5962-95788
		REVISION LEVEL	SHEET 5

TABLE I. Electrical performance characteristics - Continued.

Test	Symbol	Test conditions <u>1/</u> -55° C ≤ C ≤ +125° C unless otherwise specified	Device type	V _{CC}	Group A subgroups	Limits <u>2/</u>		Unit					
						Min	Max						
Output current high (Source)	I _{OH}	For all inputs affecting output under test, V _{IN} = 4.5 V or 0.0 V For all other inputs V _{IN} = V _{CC} or GND V _{OUT} = 4.1 V	All	4.5 V	1	-4.8		mA					
									M, D, L, R <u>3/</u>	All	1	-4.0	
Output current low (Sink)	I _{OL}	For all inputs affecting output under test, V _{IN} = 4.5 V or 0.0 V For all other inputs V _{IN} = V _{CC} or GND V _{OUT} = 0.4 V	All	4.5 V	1	4.8		mA					
									M, D, L, R <u>3/</u>	All	1	4.0	
Quiescent supply current	I _{CC}	V _{IN} = V _{CC} or GND	All	5.5 V	1		40.0	μA					
									M, D, L, R <u>3/</u>	All	1	750.0	
Input capacitance	C _{IN}	V _{IH} = 5.0 V, V _{IL} = 0.0 V, f = 1 MHz, see 4.4.1c	All	5.0 V	4		10	pF					
Power dissipation capacitance	C _{PD} <u>4/</u>		All	5.0 V	4		53	pF					
Functional test	<u>5/</u>	V _{IH} = 3.15 V, V _{IL} = 1.35 V, See 4.4.1b	All	4.5 V	7, 8	L	H						
									M, D, L, R <u>3/</u>	All	7	L	H
Propagation delay time, CPU to Qn	t _{PHL1} <u>6/</u>	C _L = 50 pF, R _L = 500Ω, See figure 4	All	4.5 V	9	2.0	31.0	ns					
									M, D, L, R <u>3/</u>	All	9	2.0	36.0
	t _{PLH1} <u>6/</u>	C _L = 50 pF, R _L = 500Ω, See figure 4	All	4.5 V	9	2.0	31.0	ns					
									M, D, L, R <u>3/</u>	All	9	2.0	38.0
Propagation delay time, CPU to TCU	t _{PHL2} , t _{PLH2} <u>6/</u>	C _L = 50 pF, R _L = 500Ω, See figure 4	All	4.5 V	9	2.0	23.0	ns					
									M, D, L, R <u>3/</u>	All	9	2.0	27.0

See footnotes at end of table.

STANDARD MICROCIRCUIT DRAWING DEFENSE ELECTRONICS SUPPLY CENTER DAYTON, OHIO 45444	SIZE A		5962-95788
		REVISION LEVEL	SHEET 6

TABLE I. Electrical performance characteristics - Continued.

Test	Symbol	Test conditions 1/ -55° C ≤ C ≤ +125° C unless otherwise specified	Device type	V _{CC}	Group A subgroups	Limits 2/		Unit	
						Min	Max		
Propagation delay time, CPD to TCD	t _{PHL3} , t _{PLH3} 6/	C _L = 50 pF, R _L = 500Ω, See figure 4	All	4.5 V	9	2.0	23.0	ns	
						10, 11	2.0		27.0
						M, D, L, R 3/	9		2.0
Propagation delay time, CPD to Qn	t _{PHL4} 6/	C _L = 50 pF, R _L = 500Ω, See figure 4	All	4.5 V	9	2.0	31.0	ns	
						10, 11	2.0		37.0
						M, D, L, R 3/	9		2.0
	t _{PLH4} 6/	C _L = 50 pF, R _L = 500Ω, See figure 4	All	4.5 V	9	2.0	32.0	ns	
						10, 11	2.0		39.0
						M, D, L, R 3/	9		2.0
Propagation delay time, PL to Qn	t _{PHL5} 6/	C _L = 50 pF, R _L = 500Ω, See figure 4	All	4.5 V	9	2.0	34.0	ns	
						10, 11	2.0		40.0
						M, D, L, R 3/	9		2.0
	t _{PLH5} 6/	C _L = 50 pF, R _L = 500Ω, See figure 4	All	4.5 V	9	2.0	26.0	ns	
						10, 11	2.0		31.0
						M, D, L, R 3/	9		2.0
Propagation delay time, MR to Qn	t _{PHL6} 6/	C _L = 50 pF, R _L = 500Ω, See figure 4	All	4.5 V	9	2.0	33.0	ns	
						10, 11	2.0		38.0
						M, D, L, R 3/	9		2.0
Maximum operating frequency, CPU, CPD	f _{MAX} 7/	C _L = 50 pF, R _L = 500Ω, See figure 4	All	4.5 V	9	25.0	MHz		
					10, 11			17.0	
Output transition time	t _{TLH} , t _{THL} 7/	C _L = 50 pF, R _L = 500Ω, See figure 4	All	4.5 V	9		15.0	ns	
					10, 11		22.0		
Setup time, high or low, Pn to PL	t _S 7/	C _L = 50 pF, R _L = 500Ω, See figure 4	All	4.5 V	9	16.0	ns		
					10, 11	24.0			
Hold time, high or low, Pn to PL	t _{h1} 7/	C _L = 50 pF, R _L = 500Ω, See figure 4	All	4.5 V	9	0.0	ns		
					10, 11	0.0			

See footnotes at end of table.

STANDARD MICROCIRCUIT DRAWING DEFENSE ELECTRONICS SUPPLY CENTER DAYTON, OHIO 45444	SIZE A		5962-95788
		REVISION LEVEL	SHEET 7

TABLE I. Electrical performance characteristics - Continued.

Test	Symbol	Test conditions 1/ -55°C ≤ T ≤ +125°C unless otherwise specified	Device type	V _{CC}	Group A subgroups	Limits 2/		Unit
						Min	Max	
Hold time, high or low, CPD to CPU or CPU to CPD	t _{h2} Z/	C _L = 50 pF, R _L = 500Ω, See figure 4	All	4.5 V	9	16.0		ns
					10, 11	24.0		
CPU or CPD pulse width, high or low	t _{w1} Z/	C _L = 50 pF, R _L = 500Ω, See figure 4	All	4.5 V	9	20.0		ns
					10, 11	30.0		
PL pulse width, low	t _{w2}	C _L = 50 pF, R _L = 500Ω, See figure 4	All	4.5 V	9	16.0		ns
					10, 11	24.0		
MR pulse width, high	t _{w3} Z/	C _L = 50 pF, R _L = 500Ω, See figure 4	All	4.5 V	9	20.0		ns
					10, 11	30.0		
Recovery time, PL to CPU or CPD	t _{REC1} Z/	C _L = 50 pF, R _L = 500Ω, See figure 4	All	4.5 V	9	16.0		ns
					10, 11	24.0		
Recovery time, MR to CPU or CPD	t _{REC2} Z/	C _L = 50 pF, R _L = 500Ω, See figure 4	All	4.5 V	9, 10, 11	5.0		ns

- 1/ Each input/output, as applicable, shall be tested at the specified temperature, for the specified limits, to the tests in table I herein. Output terminals not designated shall be high level logic, low level logic, or open, except for the I_{CC} test, the output terminals shall be open. When performing the I_{CC} test, the current meter shall be placed in the circuit such that all current flows through the meter.
- 2/ For negative and positive voltage and current values, the sign designates the potential difference in reference to GND and the direction of current flow respectively; and the absolute value of the magnitude, not the sign, is relative to the minimum and maximum limits, as applicable, listed herein.
- 3/ Devices supplied to this drawing meet all levels M, D, L, and R of irradiation. However, this device is only tested at the "R" level. Pre and post irradiation values are identical unless otherwise specified in table I. When performing post irradiation electrical measurements for any RHA level, T_A = +25°C.
- 4/ Power dissipation capacitance (C_{PD}) determines both the power consumption (P_D) and current consumption (I_S).
Where

$$P_D = (C_{PD} + C_L) (V_{CC} \times V_{CC})f + (I_{CC} \times V_{CC})$$

$$I_S = (C_{PD} + C_L) V_{CC}f + I_{CC}$$
 f is the frequency of the input signal.
- 5/ The test vectors used to verify the truth table shall, at a minimum, test all functions of each input and output. All possible input to output logic patterns per function shall be guaranteed, if not tested, to the truth table in figure 2 herein. For V_{OUT} measurements, L ≤ 0.5 V and H ≥ 4.0 V.
- 6/ AC limits at V_{CC} = 5.5 V are equal to the limits at V_{CC} = 4.5 V. For propagation delay tests, all paths must be tested.
- Z/ This parameter is guaranteed but not tested. This parameter is characterized upon initial design or process changes which affect this characteristic.

STANDARD MICROCIRCUIT DRAWING DEFENSE ELECTRONICS SUPPLY CENTER DAYTON, OHIO 45444	SIZE A		5962-95788
		REVISION LEVEL	SHEET 8

Device type	All
Case outlines	E and X
Terminal number	Terminal symbol
1	P1
2	Q1
3	Q0
4	CPD
5	CPU
6	Q2
7	Q3
8	GND
9	P3
10	<u>P2</u>
11	<u>PL</u>
12	<u>TCU</u>
13	<u>TCD</u>
14	MR
15	P0
16	V _{CC}

FIGURE 1. Terminal connections.

Function	CPU	CPD	MR	<u>PL</u>
Count up	↑	H	L	H
Count down	H	↑	L	H
Reset	X	X	H	X
Load preset input	X	X	L	L

H = High voltage level
L = Low voltage level
X = Don't care
↑ = Low-to-high clock transition

FIGURE 2. Truth table.

STANDARD MICROCIRCUIT DRAWING DEFENSE ELECTRONICS SUPPLY CENTER DAYTON, OHIO 45444	SIZE A		5962-95788
		REVISION LEVEL	SHEET 9

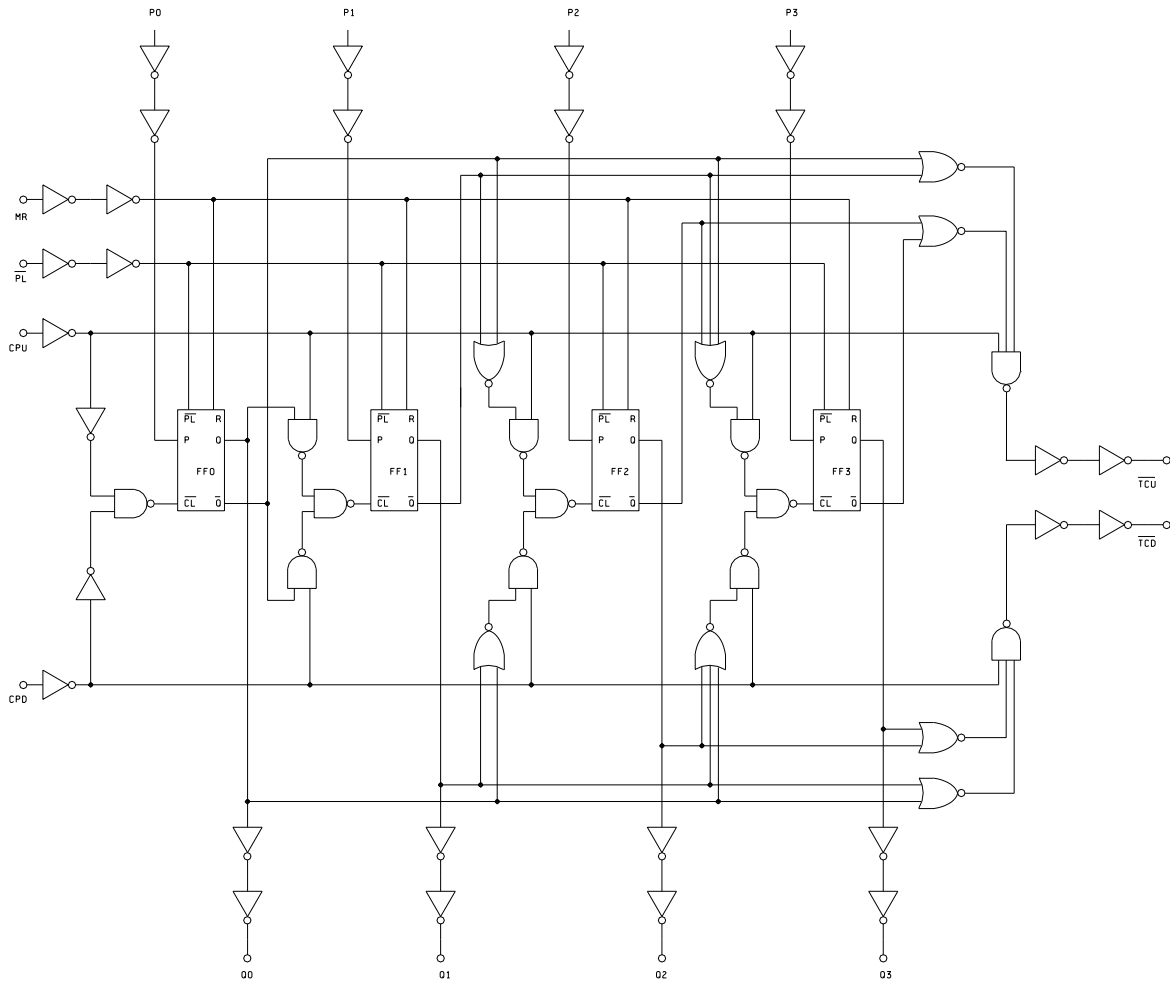

FIGURE 3. Logic diagram.

**STANDARD
MICROCIRCUIT DRAWING
DEFENSE ELECTRONICS SUPPLY CENTER
DAYTON, OHIO 45444**

SIZE
A

5962-95788

REVISION LEVEL

SHEET

10

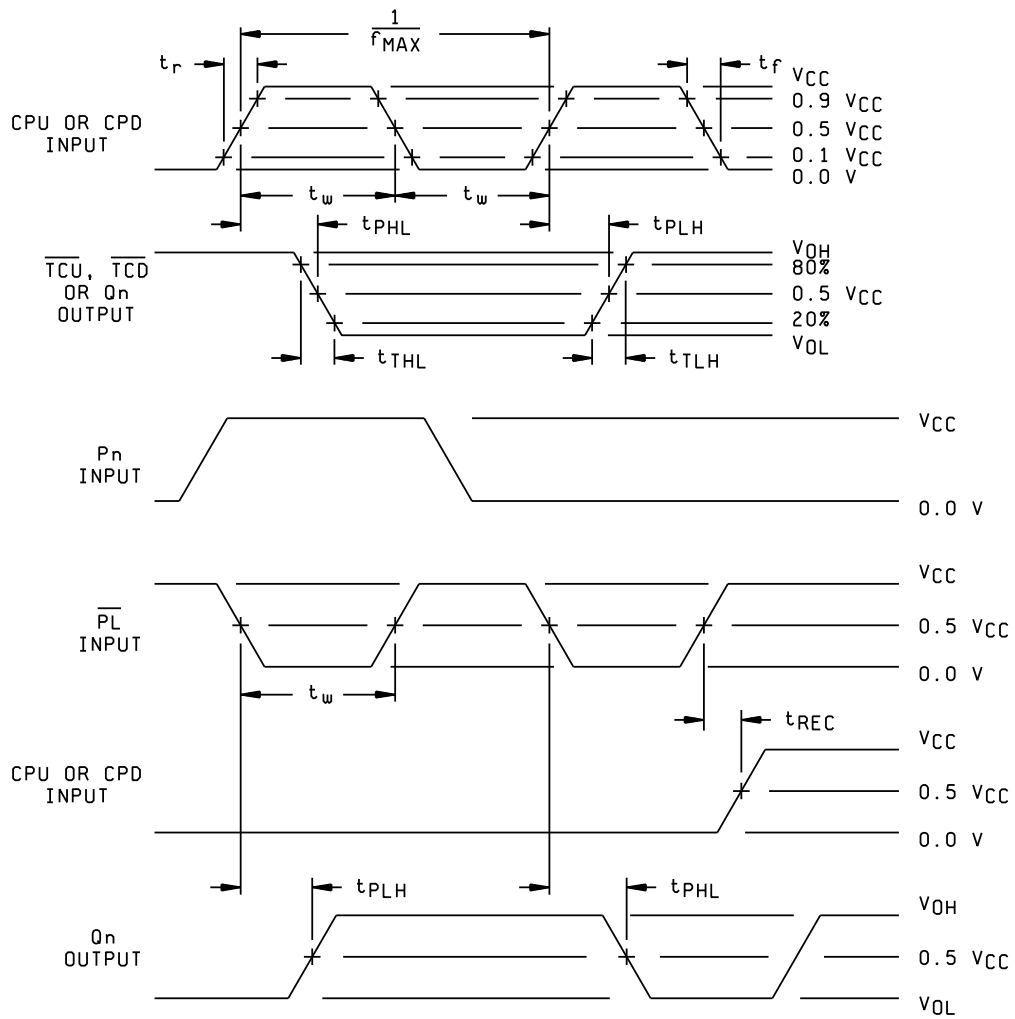

FIGURE 4. Switching waveforms and test circuit.

STANDARD
MICROCIRCUIT DRAWING
DEFENSE ELECTRONICS SUPPLY CENTER
DAYTON, OHIO 45444

SIZE
A

5962-95788

REVISION LEVEL

SHEET

11

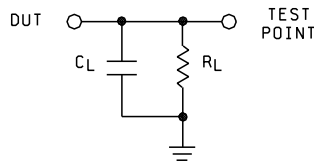
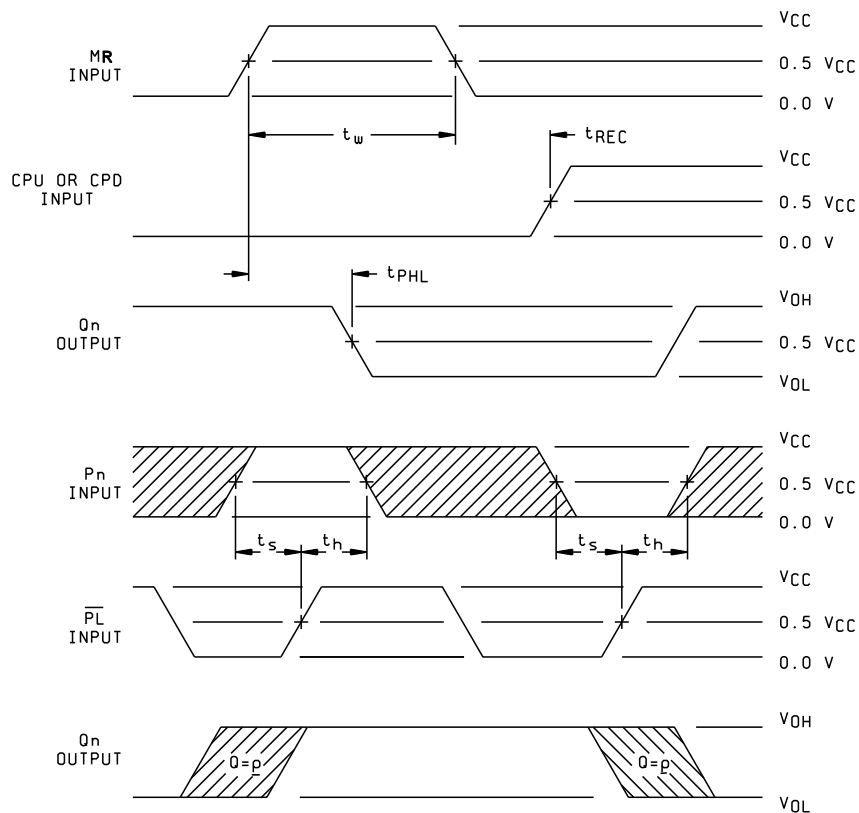

NOTES:

1. $C_L = 50$ pF minimum or equivalent (includes test jig and probe capacitance).
2. $R_L = 500\Omega$ or equivalent.
3. Input signal from pulse generator: $V_{IN} = 0.0$ V to V_{CC} ; $PRR \leq 10$ MHz; $t_r \leq 3.0$ ns; $t_f \leq 3.0$ ns; t_r and t_f shall be measured from 10% V_{CC} to 90% V_{CC} and from 90% V_{CC} to 10% V_{CC} , respectively.

FIGURE 4. Switching waveforms and test circuit - Continued.

STANDARD MICROCIRCUIT DRAWING DEFENSE ELECTRONICS SUPPLY CENTER DAYTON, OHIO 45444	SIZE A		5962-95788
		REVISION LEVEL	SHEET 12

3.6 Certificate of compliance. For device class M, a certificate of compliance shall be required from a manufacturer in order to be listed as an approved source of supply in MIL-BUL-103 (see 6.7.2 herein). For device classes Q and V, a certificate of compliance shall be required from a QML-38535 listed manufacturer in order to supply to the requirements of this drawing (see 6.7.1 herein). The certificate of compliance submitted to DESC-EC prior to listing as an approved source of supply for this drawing shall affirm that the manufacturer's product meets, for device class M, the requirements of MIL-STD-883 (see 3.1 herein), or for device classes Q and V, the requirements of MIL-I-38535 and the requirements herein.

3.7 Certificate of conformance. A certificate of conformance as required for device class M in MIL-STD-883 (see 3.1 herein) or for device classes Q and V in MIL-I-38535 shall be provided with each lot of microcircuits delivered to this drawing.

3.8 Notification of change for device class M. For device class M, notification to DESC-EC of change of product (see 6.2 herein) involving devices acquired to this drawing is required for any change as defined in MIL-STD-973.

3.9 Verification and review for device class M. For device class M, DESC, DESC's agent, and the acquiring activity retain the option to review the manufacturer's facility and applicable required documentation. Offshore documentation shall be made available onshore at the option of the reviewer.

3.10 Microcircuit group assignment for device class M. Device class M devices covered by this drawing shall be in microcircuit group number 40 (see MIL-I-38535, appendix A).

4. QUALITY ASSURANCE PROVISIONS

4.1 Sampling and inspection. For device class M, sampling and inspection procedures shall be in accordance with MIL-STD-883 (see 3.1 herein). For device classes Q and V, sampling and inspection procedures shall be in accordance with MIL-I-38535 or as modified in the device manufacturer's Quality Management (QM) plan. The modification in the QM plan shall not affect the form, fit, or function as described herein.

4.2 Screening. For device class M, screening shall be in accordance with method 5004 of MIL-STD-883, and shall be conducted on all devices prior to quality conformance inspection. For device classes Q and V, screening shall be in accordance with MIL-I-38535, and shall be conducted on all devices prior to qualification and technology conformance inspection.

4.2.1 Additional criteria for device class M.

a. Burn-in test, method 1015 of MIL-STD-883.

(1) Test condition A, B, C, or D. The test circuit shall be maintained by the manufacturer under document revision level control and shall be made available to the preparing or acquiring activity upon request. The test circuit shall specify the inputs, outputs, biases, and power dissipation, as applicable, in accordance with the intent specified in test method 1015.

(2) $T_A = +125^\circ\text{C}$, minimum.

b. Interim and final electrical test parameters shall be as specified in table IIA herein.

4.2.2 Additional criteria for device classes Q and V.

a. The burn-in test duration, test condition and test temperature, or approved alternatives shall be as specified in the device manufacturer's QM plan in accordance with MIL-I-38535. The burn-in test circuit shall be maintained under document revision level control of the device manufacturer's Technology Review Board (TRB) in accordance with MIL-I-38535 and shall be made available to the acquiring or preparing activity upon request. The test circuit shall specify the inputs, outputs, biases, and power dissipation, as applicable, in accordance with the intent specified in test method 1015.

b. Interim and final electrical test parameters shall be as specified in table IIA herein.

c. Additional screening for device class V beyond the requirements of device class Q shall be as specified in appendix B of MIL-I-38535 or as modified in the device manufacturer's Quality Management (QM) plan.

4.3 Qualification inspection for device classes Q and V. Qualification inspection for device classes Q and V shall be in accordance with MIL-I-38535. Inspections to be performed shall be those specified in MIL-I-38535 and herein for groups A, B, C, D, and E inspections (see 4.4.1 through 4.4.4).

4.3.1 Electrostatic discharge sensitivity (ESDS) qualification inspection. ESDS testing shall be performed in accordance with MIL-STD-883, method 3015. ESDS testing shall be measured only for initial qualification and after process or design changes which may affect ESDS classification.

STANDARD MICROCIRCUIT DRAWING DEFENSE ELECTRONICS SUPPLY CENTER DAYTON, OHIO 45444	SIZE A		5962-95788
		REVISION LEVEL	SHEET 13

TABLE IIA. Electrical test requirements.

Test requirements	Subgroups (in accordance with MIL-STD-883, TM 5005, table I)	Subgroups (in accordance with MIL-I-38535, table III)	
	Device class M	Device class Q	Device class V
Interim electrical parameters (see 4.2)	1, 7, 9	1, 7, 9	1, 7, 9
Final electrical parameters (see 4.2)	1, 2, 3, 7, 8, 9, 10, 11 1/	1, 2, 3, 7, 8, 9, 10, 11 1/	1, 2, 3, 7, 8, 9, 10, 11 2/ 3/
Group A test requirements (see 4.4)	1, 2, 3, 4, 5, 6, 7, 8, 9, 10, 11	1, 2, 3, 4, 5, 6, 7, 8, 9, 10, 11	1, 2, 3, 4, 5, 6, 7, 8, 9, 10, 11
Group C end-point electrical parameters (see 4.4)	1, 2, 3, 7, 8, 9, 10, 11	1, 2, 3, 7, 8, 9, 10, 11	1, 2, 3, 7, 8, 9, 10, 11 3/
Group D end-point electrical parameters (see 4.4)	1, 7, 9	1, 7, 9	1, 7, 9
Group E end-point electrical parameters (see 4.4)	1, 7, 9	1, 7, 9	1, 7, 9

1/ PDA applies to subgroups 1 and 7.

2/ PDA applies to subgroups 1, 7, 9, and 10.

3/ Delta limits as specified in table IIB herein shall be required where specified, and the delta values shall be completed with reference to the zero hour electrical parameters (see table I).

TABLE IIB. Burn-in and operating life test. Delta parameters (+25°C).

Parameters 1/	Delta limits
I_{CC}	+12 μ A
I_{OL}/I_{OH}	-15%

1/ These parameters shall be recorded before and after the required burn-in and life test to determine delta limits.

4.4 Conformance inspection. Quality conformance inspection for device class M shall be in accordance with MIL-STD-883 (see 3.1 herein) and as specified herein. Inspections to be performed for device class M shall be those specified in method 5005 of MIL-STD-883 and herein for groups A, B, C, D, and E inspections (see 4.4.1 through 4.4.4). Technology conformance inspection for classes Q and V shall be in accordance with MIL-I-38535 or as specified in QM plan including groups A, B, C, D, and E inspections and as specified herein except where option 2 of MIL-I-38535 permits alternate in-line control testing.

4.4.1 Group A inspection.

- a. Tests shall be as specified in table IIA herein.
- b. For device class M, subgroups 7 and 8 tests shall be sufficient to verify the truth table in figure 2 herein. For device classes Q and V, subgroups 7 and 8 shall include verifying the functionality of the device.
- c. C_{IN} and C_{PD} shall be measured only for initial qualification and after process or design changes which may affect capacitance. C_{IN} shall be measured between the designated terminal and GND at a frequency of 1 MHz. For C_{IN} and C_{PD} , tests shall be sufficient to validate the limits defined in table I herein.

STANDARD MICROCIRCUIT DRAWING DEFENSE ELECTRONICS SUPPLY CENTER DAYTON, OHIO 45444	SIZE A		5962-95788
		REVISION LEVEL	SHEET 14

4.4.2 Group C inspection. The group C inspection end-point electrical parameters shall be as specified in table IIA herein.

4.4.2.1 Additional criteria for device class M. Steady-state life test conditions, method 1005 of MIL-STD-883:

- a. Test condition A, B, C, or D. The test circuit shall be maintained by the manufacturer under document revision level control and shall be made available to the preparing or acquiring activity upon request. The test circuit shall specify the inputs, outputs, biases, and power dissipation, as applicable, in accordance with the intent specified in test method 1005.
- b. $T_A = +125^\circ\text{C}$, minimum.
- c. Test duration: 1,000 hours, except as permitted by method 1005 of MIL-STD-883.

4.4.2.2 Additional criteria for device classes Q and V. The steady-state life test duration, test condition and test temperature, or approved alternatives shall be as specified in the device manufacturer's QM plan in accordance with MIL-I-38535. The test circuit shall be maintained under document revision level control by the device manufacturer's TRB, in accordance with MIL-I-38535, and shall be made available to the acquiring or preparing activity upon request. The test circuit shall specify the inputs, outputs, biases, and power dissipation, as applicable, in accordance with the intent specified in test method 1005.

4.4.3 Group D inspection. The group D inspection end-point electrical parameters shall be as specified in table IIA herein.

4.4.4 Group E inspection. Group E inspection is required only for parts intended to be marked as radiation hardness assured (see 3.5 herein). RHA levels for device classes M, Q, and V shall be as specified in MIL-I-38535. End-point electrical parameters shall be as specified in table IIA herein.

4.4.4.1 Total dose irradiation testing. Total dose irradiation testing shall be performed in accordance with MIL-STD-883, test method 1019 and as specified herein.

4.4.4.1.1 Accelerated aging testing. Accelerated aging testing shall be performed on all devices requiring a RHA level greater than 5k rads (Si). The post-anneal end-point electrical parameter limits shall be as specified in table I herein and shall be the pre-irradiation end-point electrical parameter limits at $25^\circ\text{C} \pm 5^\circ\text{C}$. Testing shall be performed at initial qualification and after any design or process changes which may affect the RHA response of the device.

4.4.4.2 Dose rate induced latchup testing. Dose rate induced latchup testing shall be performed in accordance with test method 1020 of MIL-STD-883 and as specified herein (see 1.4 herein). Tests shall be performed on devices, SEC, or approved test structures at technology qualification and after any design or process changes which may effect the RHA capability of the process.

4.4.4.3 Dose rate upset testing. Dose rate upset testing shall be performed in accordance with test method 1021 of MIL-STD-883 and herein (see 1.4 herein).

- a. Transient dose rate upset testing shall be performed at initial qualification and after any design or process changes which may affect the RHA performance of the devices. Test 10 devices with 0 defects unless otherwise specified.
- b. Transient dose rate upset testing for class Q and V devices shall be performed as specified by a TRB approved radiation hardness assurance plan and MIL-I-38535.

TABLE III. Irradiation test connections.

Open	Ground	$V_{CC} = 5\text{ V} \pm 0.5\text{ V}$
2, 3, 6, 7, 12, 13	8	1, 4, 5, 9, 10, 11, 14, 15, 16

NOTE: Each pin except V_{CC} and GND will have a resistor of $47\text{ k}\Omega \pm 5\%$ for irradiation testing.

STANDARD MICROCIRCUIT DRAWING DEFENSE ELECTRONICS SUPPLY CENTER DAYTON, OHIO 45444	SIZE A		5962-95788
		REVISION LEVEL	SHEET 15

4.4.4.4 Single event phenomena (SEP). SEP testing shall be required on class V devices (see 1.4 herein). SEP testing shall be performed on a technology process on the Standard Evaluation Circuit (SEC) or alternate SEP test vehicle as approved by the qualifying activity at initial qualification and after any design or process changes which may affect the upset or latchup characteristics. The recommended test conditions for SEP are as follows:

- a. The ion beam angle of incidence shall be between normal to the die surface and 60° to the normal, inclusive (i.e. $0^\circ \leq \text{angle} \leq 60^\circ$). No shadowing of the ion beam due to fixturing or package related effects is allowed.
- b. The fluence shall be ≥ 100 errors or $\geq 10^6$ ions/cm².
- c. The flux shall be between 10^2 and 10^5 ions/cm²/s. The cross-section shall be verified to be flux independent by measuring the cross-section at two flux rates which differ by at least an order of magnitude.
- d. The particle range shall be ≥ 20 micron in silicon.
- e. The test temperature shall be +25° C and the maximum rated operating temperature $\pm 10^\circ$ C.
- f. Bias conditions shall be defined by the manufacturer for the latchup measurements.
- g. Test four devices with zero failures.

4.5 Methods of inspection. Methods of inspection shall be specified as follows:

4.5.1 Voltage and current. Unless otherwise specified, all voltages given are referenced to the microcircuit GND terminal. Currents given are conventional current and positive when flowing into the referenced terminal.

5. PACKAGING

5.1 Packaging requirements. The requirements for packaging shall be in accordance with MIL-STD-883 (see 3.1 herein) for device class M and MIL-I-38535 for device classes Q and V.

6. NOTES

6.1 Intended use. Microcircuits conforming to this drawing are intended for use for Government microcircuit applications (original equipment), design applications, and logistics purposes.

6.1.1 Replaceability. Microcircuits covered by this drawing will replace the same generic device covered by a contractor-prepared specification or drawing.

6.1.2 Substitutability. Device class Q devices will replace device class M devices.

6.2 Configuration control of SMD's. All proposed changes to existing SMD's will be coordinated with the users of record for the individual documents. This coordination will be accomplished in accordance with MIL-STD-973 using DD Form 1692, Engineering Change Proposal.

6.3 Record of users. Military and industrial users shall inform Defense Electronics Supply Center when a system application requires configuration control and which SMD's are applicable to that system. DESC will maintain a record of users and this list will be used for coordination and distribution of changes to the drawings. Users of drawings covering microelectronic devices (FSC 5962) should contact DESC-EC, telephone (513) 296-6047.

6.4 Comments. Comments on this drawing should be directed to DESC-EC, Dayton, Ohio 45444-5270, or telephone (513) 296-5377.

6.5 Abbreviations, symbols, and definitions. The abbreviations, symbols, and definitions used herein are defined in MIL-I-38535 and MIL-STD-1331.

- GND Ground zero voltage potential.
- I_{CC} Quiescent supply current.
- I_{IL} Input current low.
- I_{IH} Input current high.
- T_C Case temperature.
- T_A Ambient temperature.
- V_{CC} Positive supply voltage.
- C_{IN} Input terminal-to-GND capacitance.
- C_{PD} Power dissipation capacitance.

STANDARD MICROCIRCUIT DRAWING DEFENSE ELECTRONICS SUPPLY CENTER DAYTON, OHIO 45444	SIZE A		5962-95788
		REVISION LEVEL	SHEET 16

6.6 One part - one part number system. The one part - one part number system described below has been developed to allow for transitions between identical generic devices covered by the three major microcircuit requirements documents (MIL-H-38534, MIL-I-38535, and 1.2.1 of MIL-STD-883) without the necessity for the generation of unique PIN's. The three military requirements documents represent different class levels, and previously when a device manufacturer upgraded military product from one class level to another, the benefits of the upgraded product were unavailable to the Original Equipment Manufacturer (OEM), that was contractually locked into the original unique PIN. By establishing a one part number system covering all three documents, the OEM can acquire to the highest class level available for a given generic device to meet system needs without modifying the original contract parts selection criteria.

<u>Military documentation format</u>	<u>Example PIN under new system</u>	<u>Manufacturing source listing</u>	<u>Document listing</u>
New MIL-H-38534 Standard Microcircuit Drawings	5962-XXXXXZZ(H or K)YY	QML-38534	MIL-BUL-103
New MIL-I-38535 Standard Microcircuit Drawings	5962-XXXXXZZ(Q or V)YY	QML-38535	MIL-BUL-103
New 1.2.1 of MIL-STD-883 Standard Microcircuit Drawings	5962-XXXXXZZ(M)YY	MIL-BUL-103	MIL-BUL-103

6.7 Sources of supply.

6.7.1 Sources of supply for device classes Q and V. Sources of supply for device classes Q and V are listed in QML-38535. The vendors listed in QML-38535 have submitted a certificate of compliance (see 3.6 herein) to DESC-EC and have agreed to this drawing.

6.7.2 Approved sources of supply for device class M. Approved sources of supply for class M are listed in MIL-BUL-103. The vendors listed in MIL-BUL-103 have agreed to this drawing and a certificate of compliance (see 3.6 herein) has been submitted to and accepted by DESC-EC.

6.8 Additional information. A copy of the following additional data shall be maintained and available from the device manufacturer:

- a. RHA upset levels.
- b. Test conditions (SEP).
- c. Number of upsets (SEP).
- d. Number of transients (SEP).
- e. Occurrence of latchup (SEP).

STANDARD MICROCIRCUIT DRAWING DEFENSE ELECTRONICS SUPPLY CENTER DAYTON, OHIO 45444	SIZE A		5962-95788
		REVISION LEVEL	SHEET 17

STANDARD MICROCIRCUIT DRAWING SOURCE APPROVAL BULLETIN

DATE: 95-11-08

Approved sources of supply for SMD 5962-95788 are listed below for immediate acquisition only and shall be added to MIL-BUL-103 and QML-38535 during the next revision. MIL-BUL-103 and QML-38535 will be revised to include the addition or deletion of sources. The vendors listed below have agreed to this drawing and a certificate of compliance has been submitted to and accepted by DESC-EC. This bulletin is superseded by the next dated revision of MIL-BUL-103 and QML-38535.

Standard microcircuit drawing PIN	Vendor CAGE number	Vendor similar PIN <u>1/</u>
5962R9578801VEC	34371	HCS193DMSR
5962R9578801VXC	34371	HCS193KMSR

1/ Caution. Do not use this number for item acquisition. Items acquired to this number may not satisfy the performance requirements of this drawing.

Vendor CAGE
number

34371

Vendor name
and address

Harris Semiconductor
P.O. Box 883
Melbourne, FL 32902-0883

The information contained herein is disseminated for convenience only and the Government assumes no liability whatsoever for any inaccuracies in the information bulletin.