

REVISIONS

LTR	DESCRIPTION	DATE (YR-MO-DA)	APPROVED

REV																			
SHEET																			
REV																			
SHEET																			

REV STATUS OF SHEETS	REV																	
	SHEET	1	2	3	4	5	6	7	8	9	10	11	12	13				

PMIC N/A	PREPARED BY Thomas M. Hess	DEFENSE ELECTRONICS SUPPLY CENTER DAYTON, OHIO 45444												
<p><b>STANDARD MICROCIRCUIT DRAWING</b></p> <p>THIS DRAWING IS AVAILABLE FOR USE BY ALL DEPARTMENTS AND AGENCIES OF THE DEPARTMENT OF DEFENSE</p> <p>AMSC N/A</p>	CHECKED BY Thomas M. Hess	MICROCIRCUIT, DIGITAL, CMOS, OCTAL LATCHING BUS DRIVER, MONOLITHIC SILICON												
	APPROVED BY Monica L. Poelking													
	DRAWING APPROVAL DATE 95-12-28	SIZE <b>A</b>	CAGE CODE <b>67268</b>	<b>5962-95716</b>										
	REVISION LEVEL	SHEET 1 OF 13												

DESC FORM 193  
JUL 94

DISTRIBUTION STATEMENT A. Approved for public release; distribution is unlimited.

5962-E238-96

1. SCOPE

1.1 Scope. This drawing forms a part of a one part - one part number documentation system (see 6.6 herein). Two product assurance classes consisting of military high reliability (device classes Q and M) and space application (device class V), and a choice of case outlines and lead finishes are available and are reflected in the Part or Identifying Number (PIN). Device class M microcircuits represent non-JAN class B microcircuits in accordance with 1.2.1 of MIL-STD-883, "Provisions for the use of MIL-STD-883 in conjunction with compliant non-JAN devices". When available, a choice of Radiation Hardness Assurance (RHA) levels are reflected in the PIN.

1.2 PIN. The PIN shall be as shown in the following example:

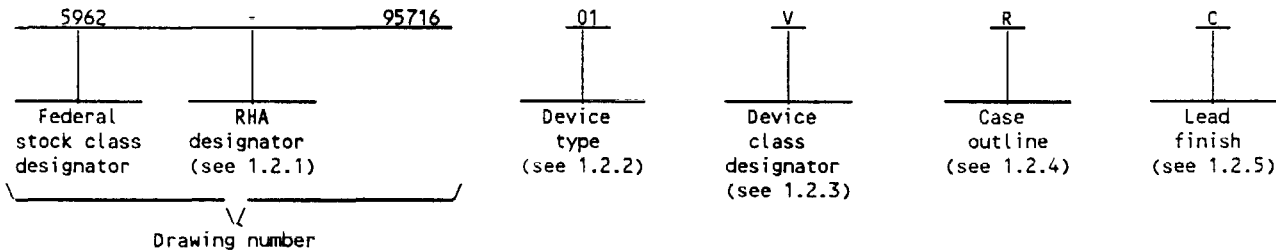

1.2.1 RHA designator. Device class M RHA marked devices shall meet the MIL-I-38535 appendix A specified RHA levels and shall be marked with the appropriate RHA designator. Device classes Q and V RHA marked devices shall meet the MIL-I-38535 specified RHA levels and shall be marked with the appropriate RHA designator. A dash (-) indicates a non-RHA device.

1.2.2 Device type(s). The device type(s) shall identify the circuit function as follows:

<u>Device type</u>	<u>Generic number</u>	<u>Circuit function</u>
01	82C82/7	Latchup resistant CMOS octal latching bus driver

1.2.3 Device class designator. The device class designator shall be a single letter identifying the product assurance level as follows:

<u>Device class</u>	<u>Device requirements documentation</u>
M	Vendor self-certification to the requirements for non-JAN class B microcircuits in accordance with 1.2.1 of MIL-STD-883
Q or V	Certification and qualification to MIL-I-38535

1.2.4 Case outline(s). The case outline(s) shall be as designated in MIL-STD-1835 and as follows:

<u>Outline letter</u>	<u>Descriptive designator</u>	<u>Terminals</u>	<u>Package style</u>
R	CDIP2-T20	20	Dual-in-line package

1.2.5 Lead finish. The lead finish shall be as specified in MIL-STD-883 (see 3.1 herein) for class M or MIL-I-38535 for classes Q and V. Finish letter "X" shall not be marked on the microcircuit or its packaging. The "X" designation is for use in specifications when lead finishes A, B, and C are considered acceptable and interchangeable without preference.

STANDARD MICROCIRCUIT DRAWING DEFENSE ELECTRONICS SUPPLY CENTER DAYTON, OHIO 45444	SIZE <b>A</b>		5962-95716
		REVISION LEVEL	SHEET 2

1.3 Absolute maximum ratings. 1/

Supply voltage ( $V_{CC}$ ) - - - - -	+8.0 V dc
Input or output voltage range - - - - -	GND -0.5 v dc to $V_{CC}$ +0.5 V dc
Storage temperature range ( $T_{STG}$ ) - - - - -	-65°C to +150°C
Thermal resistance, Junction-to-case ( $\theta_{JC}$ ) - - - - -	12°C/W
Thermal resistance, Junction-to-ambient ( $\theta_{JA}$ ) - - - - -	68°C/W
Maximum package power dissipation at $T_A = +125^\circ\text{C}$ ( $P_D$ ) 2/ - - - -	0.73 W
Junction temperature ( $T_J$ ) - - - - -	+175°C
Lead temperature (soldering, 10 seconds) - - - - -	+300°C

1.4 Recommended operating conditions.

Operating supply voltage range ( $V_{DD}$ ) - - - - -	4.5 V dc to +5.5 V dc
Operating temperature range ( $T_A$ ) - - - - -	-55°C to +125°C
Input low voltage range ( $V_{IL}$ ) - - - - -	0 V dc to +0.8 V dc
Input high voltage range ( $V_{IH}$ ) - - - - -	2.2 V dc to $V_{DD}$

2. APPLICABLE DOCUMENTS

2.1 Government specification, standards, bulletin, and handbook. Unless otherwise specified, the following specification, standards, bulletin, and handbook of the issue listed in that issue of the Department of Defense Index of Specifications and Standards specified in the solicitation, form a part of this drawing to the extent specified herein.

SPECIFICATION

MILITARY

MIL-I-38535 - Integrated Circuits, Manufacturing, General Specification for.

STANDARDS

MILITARY

- MIL-STD-883 - Test Methods and Procedures for Microelectronics.
- MIL-STD-973 - Configuration Management.
- MIL-STD-1835 - Microcircuit Case Outlines.

BULLETIN

MILITARY

MIL-BUL-103 - List of Standardized Military Drawings (SMD's).

HANDBOOK

MILITARY

MIL-HDBK-780 - Standardized Military Drawings.

(Copies of the specification, standards, bulletin, and handbook required by manufacturers in connection with specific acquisition functions should be obtained from the contracting activity or as directed by the contracting activity.)

2.2 Order of precedence. In the event of a conflict between the text of this drawing and the references cited herein, the text of this drawing shall take precedence.

1/ Stresses above the absolute maximum rating may cause permanent damage to the device. Extended operation at the maximum levels may degrade performance and affect reliability.  
 2/ If device power exceeds package dissipation capability, provide heat sinking or derate linearly (the derating is based on  $\theta_{JA}$ ) at the rate of 14.7 mW/°C.

STANDARD MICROCIRCUIT DRAWING DEFENSE ELECTRONICS SUPPLY CENTER DAYTON, OHIO 45444	SIZE <b>A</b>		5962-95716
		REVISION LEVEL	SHEET 3

### 3. REQUIREMENTS

3.1 Item requirements. The individual item requirements for device class M shall be in accordance with 1.2.1 of MIL-STD-883, "Provisions for the use of MIL-STD-883 in conjunction with compliant non-JAN devices" and as specified herein. The individual item requirements for device classes Q and V shall be in accordance with MIL-I-38535 and as specified herein or as modified in the device manufacturer's Quality Management (QM) plan. The modification in the QM plan shall not effect the form, fit, or function as described herein.

3.2 Design, construction, and physical dimensions. The design, construction, and physical dimensions shall be as specified in MIL-STD-883 (see 3.1 herein) for device class M and MIL-I-38535 for device classes Q and V and herein.

3.2.1 Case outline(s). The case outline(s) shall be in accordance with 1.2.4 herein.

3.2.2 Terminal connections. The terminal connections shall be as specified on figure 1.

3.2.3 Block diagram. The block diagram shall be as specified on figure 2.

3.2.4 Timing waveforms. The timing waveforms shall be as specified in figure 3.

3.3 Electrical performance characteristics and postirradiation parameter limits. Unless otherwise specified herein, the electrical performance characteristics and postirradiation parameter limits are as specified in table I and shall apply over the full ambient operating temperature range.

3.4 Electrical test requirements. The electrical test requirements shall be the subgroups specified in table IIA. The electrical tests for each subgroup are defined in table I.

3.5 Marking. The part shall be marked with the PIN listed in 1.2 herein. Marking for device class M shall be in accordance with MIL-STD-883 (see 3.1 herein). In addition, the manufacturer's PIN may also be marked as listed in MIL-BUL-103. Marking for device classes Q and V shall be in accordance with MIL-I-38535.

3.5.1 Certification/compliance mark. The compliance mark for device class M shall be a "C" as required in MIL-STD-883 (see 3.1 herein). The certification mark for device classes Q and V shall be a "QML" or "Q" as required in MIL-I-38535.

3.6 Certificate of compliance. For device class M, a certificate of compliance shall be required from a manufacturer in order to be listed as an approved source of supply in MIL-BUL-103 (see 6.7.2 herein). For device classes Q and V, a certificate of compliance shall be required from a QML-38535 listed manufacturer in order to supply to the requirements of this drawing (see 6.7.1 herein). The certificate of compliance submitted to DESC-EC prior to listing as an approved source of supply for this drawing shall affirm that the manufacturer's product meets, for device class M, the requirements of MIL-STD-883 (see 3.1 herein), or for device classes Q and V, the requirements of MIL-I-38535 and the requirements herein.

3.7 Certificate of conformance. A certificate of conformance as required for device class M in MIL-STD-883 (see 3.1 herein) or for device classes Q and V in MIL-I-38535 shall be provided with each lot of microcircuits delivered to this drawing.

3.8 Notification of change for device class M. For device class M, notification to DESC-EC of change of product (see 6.2 herein) involving devices acquired to this drawing is required for any change as defined in MIL-STD-973.

3.9 Verification and review for device class M. For device class M, DESC, DESC's agent, and the acquiring activity retain the option to review the manufacturer's facility and applicable required documentation. Offshore documentation shall be made available onshore at the option of the reviewer.

3.10 Microcircuit group assignment for device class M. Device class M devices covered by this drawing shall be in microcircuit group number 105 (see MIL-I-38535, appendix A).

STANDARD MICROCIRCUIT DRAWING DEFENSE ELECTRONICS SUPPLY CENTER DAYTON, OHIO 45444	SIZE <b>A</b>		5962-95716
		REVISION LEVEL	SHEET 4

TABLE I. Electrical performance characteristics.

Test	Symbol	Conditions -55°C ≤ T <sub>A</sub> ≤ +125°C unless otherwise specified 1/	Group A subgroups	Device type	Limits		Unit
					Min	Max	
Logical "1" input voltage	V <sub>IH</sub>	V <sub>CC</sub> = 5.5 V 2/ 3/ Pins 1-8,9,11	1,2,3	ALL	2.2		V
Logical "0" input voltage	V <sub>IL</sub>	V <sub>CC</sub> = 4.5 V 3/ Pins 1-8,9,11	1,2,3	ALL		0.8	V
Output HIGH voltage	V <sub>OHI</sub>	V <sub>CC</sub> = 4.5 V, $\overline{OE}$ = GND 4/ I <sub>OH</sub> = -8.0 mA, Pins 12-19	1,2,3	ALL	2.9		V
	V <sub>OHz</sub>	V <sub>CC</sub> = 4.5 V, $\overline{OE}$ = GND 4/ I <sub>OH</sub> = -100 μA, Pins 12-19			V <sub>CC</sub> -0.4		
Output LOW voltage	V <sub>OL</sub>	V <sub>CC</sub> = 4.5 V, $\overline{OE}$ = GND 4/ I <sub>OL</sub> = +8.0 mA, Pins 12-19	1,2,3	ALL		0.4	V
Input leakage current	I <sub>IH</sub> I <sub>IL</sub>	V <sub>CC</sub> = 5.5 V, V <sub>IN</sub> = GND or V <sub>CC</sub> Pins 1-9, 11	1,2,3	ALL	-1.0	1.0	μA
Output leakage current	I <sub>OZL</sub> I <sub>OZH</sub>	V <sub>CC</sub> = 5.5 V, $\overline{OE}$ > = V <sub>CC</sub> -0.5 V V <sub>OUT</sub> = GND or V <sub>CC</sub> PINS 12-19	1,2,3	ALL	-10	10	μA
Standby power supply current	I <sub>CCSB</sub>	V <sub>CC</sub> = 5.5 V, V <sub>IN</sub> = GND or V <sub>DD</sub> Outputs open	1,2,3	ALL		10.0	μA
Input capacitance	C <sub>IN</sub>	V <sub>CC</sub> = Open, f = 1 MHz All measurements referenced to GND	4	ALL		13	pF
Output capacitance	C <sub>OUT</sub>	See 4.4.1c	4	ALL		20	pF
Functional tests		See 4.4.1b V <sub>CC</sub> = 4.5 V and 5.5 V 5/	7,8	ALL			

TIMING REQUIREMENTS

Propagation delay, input to output	t <sub>I<sub>VOV</sub></sub>	V <sub>CC</sub> = 4.5 V 6/ 7/	9,10,11	ALL		40	ns
Propagation delay, STB to output	t <sub>SHOV</sub>		9,10,11	ALL		55	ns

See footnotes at end of table.

<p>STANDARD MICROCIRCUIT DRAWING DEFENSE ELECTRONICS SUPPLY CENTER DAYTON, OHIO 45444</p>	SIZE <b>A</b>		5962-95716
		REVISION LEVEL	SHEET 5

TABLE I. Electrical performance characteristics - Continued.

Test	Symbol	Conditions 1/ -55°C ≤ T <sub>A</sub> ≤ +125°C unless otherwise specified	Group A subgroups	Device type	Limits		Unit
					Min	Max	
<b>TIMING REQUIREMENTS - CONTINUED.</b>							
Output enable time	t <sub>ELOV</sub>	V <sub>CC</sub> = 4.5 V 6/ 7/	9,10,11	All		50	ns
Input to STB setup time	t <sub>IVSL</sub>		9,10,11	All	0		ns
Input to STB hold time	t <sub>SLIX</sub>		9,10,11	All	25		ns
STB high time	t <sub>SHSL</sub>		9,10,11	All	25		ns
Output disable time	t <sub>EHOZ</sub>	8/ 9/	9,10,11	All		40	ns
Input rise/fall time	t <sub>R</sub> t <sub>F</sub>	8/	9,10,11	All		20	ns

- 1/ All testing to be performed using worst case test conditions unless otherwise specified.
- 2/ V<sub>IH</sub> is measured by applying a pulse of magnitude = V<sub>IH</sub> min to one data input at a time and checking the corresponding device output for a valid logical "1" during valid input high time. Control pins (STB, CE) are tested separately with all device data inputs at V<sub>CC</sub>-0.4 v.
- 3/ Go/no go test
- 4/ Interchanging of force and sense conditions is permitted.
- 5/ f = 1 MHz, V<sub>IH</sub> = 2.6 V (V<sub>IH</sub> for STB > = V<sub>CC</sub>-0.5 V), V<sub>IL</sub> = 0.4 V, C<sub>L</sub> = 50 pF, V<sub>OH</sub> = 1.5 V, V<sub>OL</sub> = 1.5 V.
- 6/ All ac parameter tested as per test load circuits and definitions on figures 4. Input rise and fall times are driven at 1 V/ns.
- 7/ Unless otherwise specified, test as follows: f = 1 MHz, V<sub>IH</sub> = 2.6 V (V<sub>IH</sub> for STB > = V<sub>CC</sub>-0.5), V<sub>IL</sub> = 0.4 V, C<sub>L</sub> = 50 pF V<sub>OH</sub> > = 1.5 V, V<sub>OL</sub> < = 1.5 V, V<sub>CC</sub> = 4.5.
- 8/ The parameters listed are controlled via design of process parameters and are not directly listed. These parameters are characterized upon initial design and after major process and/or design changes.
- 9/ Unless otherwise specified, test as follows: f = 1 MHz, V<sub>IH</sub> = 2.6 V (V<sub>IH</sub> for STB > = V<sub>CC</sub>-0.5), V<sub>IL</sub> = 0.4 V, C<sub>L</sub> = 50 pF V<sub>OH</sub> > = 1.5 V, V<sub>OL</sub> < = 1.5 V, V<sub>CC</sub> = 4.5. and 5.5 V.

STANDARD MICROCIRCUIT DRAWING DEFENSE ELECTRONICS SUPPLY CENTER DAYTON, OHIO 45444	SIZE <b>A</b>		5962-95716
		REVISION LEVEL	SHEET 6

Device type	
Case outline	
Terminal number	Terminal symbol
1	DI <sub>0</sub>
2	DI <sub>1</sub>
3	DI <sub>2</sub>
4	DI <sub>3</sub>
5	DI <sub>4</sub>
6	DI <sub>5</sub>
7	DI <sub>6</sub>
8	DI <sub>7</sub>
9	$\overline{\text{OE}}$
10	GND
11	STB
12	DO <sub>7</sub>
13	DO <sub>6</sub>
14	DO <sub>5</sub>
15	DO <sub>4</sub>
16	DO <sub>3</sub>
17	DO <sub>2</sub>
18	DO <sub>1</sub>
19	DO <sub>0</sub>
20	V <sub>CC</sub>

FIGURE 1. Terminal connections.

<b>STANDARD MICROCIRCUIT DRAWING DEFENSE ELECTRONICS SUPPLY CENTER DAYTON, OHIO 45444</b>	<b>SIZE A</b>		<b>5962-95716</b>
		<b>REVISION LEVEL</b>	<b>SHEET 7</b>

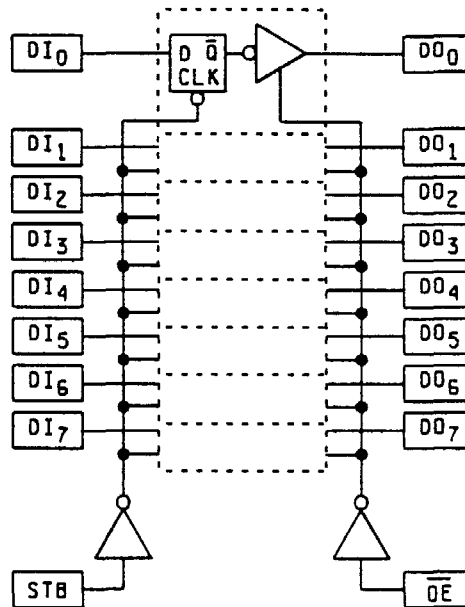

FIGURE 2. Block diagram.

STB	$\overline{OE}$	DI	DO
X	H	X	HI-Z
H	L	L	L
H	L	H	H
J	L	X	*

H = Logic 1  
 L = Logic 0  
 X = Don't care  
 HI-Z = High Impedance  
 J = Neg. transition  
 \* = latched to value of last data

Figure 3. Truth table

STANDARD MICROCIRCUIT DRAWING DEFENSE ELECTRONICS SUPPLY CENTER DAYTON, OHIO 45444	SIZE <b>A</b>		<b>5962-95716</b>
		REVISION LEVEL	SHEET 8



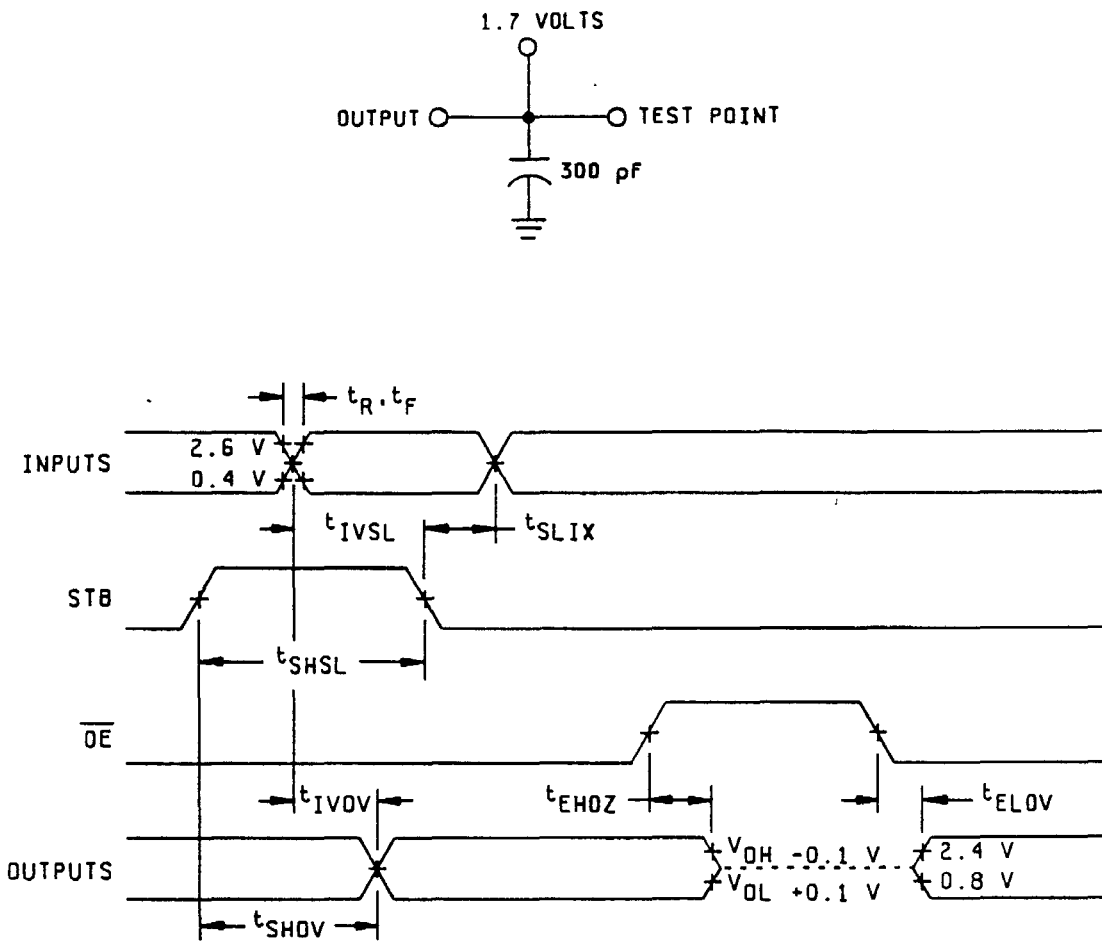

STB  $V_{IN} = V_{DD} - 0.5 V$ ,  $V_{IL} = 0.4 V$   
 ALL MEASUREMENTS ARE MADE AT 1.0 V  
 UNLESS OTHERWISE NOTED.

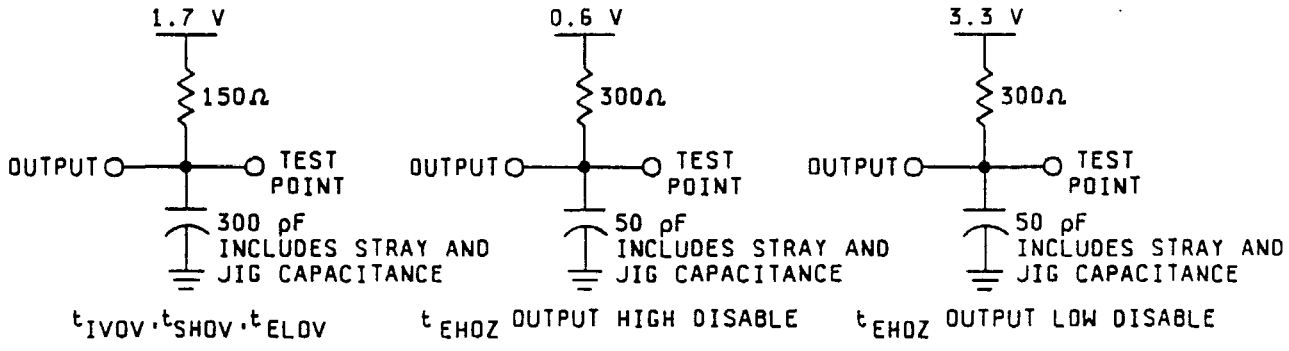

FIGURE 4. Timing waveform and test circuit.

STANDARD MICROCIRCUIT DRAWING DEFENSE ELECTRONICS SUPPLY CENTER DAYTON, OHIO 45444	SIZE <b>A</b>		5962-95716
		REVISION LEVEL	SHEET 9

4. QUALITY ASSURANCE PROVISIONS

4.1 Sampling and inspection. For device class M, sampling and inspection procedures shall be in accordance with MIL-STD-883 (see 3.1 herein). For device classes Q and V, sampling and inspection procedures shall be in accordance with MIL-I-38535 or as modified in the device manufacturer's Quality Management (QM) plan. The modification in the QM plan shall not effect the form, fit, or function as described herein.

4.2 Screening. For device class M, screening shall be in accordance with method 5004 of MIL-STD-883, and shall be conducted on all devices prior to quality conformance inspection. For device classes Q and V, screening shall be in accordance with MIL-I-38535, and shall be conducted on all devices prior to qualification and technology conformance inspection.

4.2.1 Additional criteria for device class M.

a. Burn-in test, method 1015 of MIL-STD-883.

(1) Test condition A, B, C or D. The test circuit shall be maintained by the manufacturer under document revision level control and shall be made available to the preparing or acquiring activity upon request. The test circuit shall specify the inputs, outputs, biases, and power dissipation, as applicable, in accordance with the intent specified in test method 1015.

(2)  $T_A = +125^{\circ}\text{C}$ , minimum.

b. Interim and final electrical test parameters shall be as specified in table IIA herein.

4.2.2 Additional criteria for device classes Q and V.

a. The burn-in test duration, test condition and test temperature, or approved alternatives shall be as specified in the device manufacturer's QM plan in accordance with MIL-I-38535. The burn-in test circuit shall be maintained under document revision level control of the device manufacturer's Technology Review Board (TRB) in accordance with MIL-I-38535 and shall be made available to the acquiring or preparing activity upon request. The test circuit shall specify the inputs, outputs, biases, and power dissipation, as applicable, in accordance with the intent specified in test method 1015.

b. Interim and final electrical test parameters shall be as specified in table IIA herein.

c. Additional screening for device class V beyond the requirements of device class Q shall be as specified in appendix B of MIL-I-38535, or as modified in the device manufacturers approved Quality Management (QM) plan.

4.3 Qualification inspection for device classes Q and V. Qualification inspection for device classes Q and V shall be in accordance with MIL-I-38535. Inspections to be performed shall be those specified in MIL-I-38535 and herein for groups A, B, C, D, and E inspections (see 4.4.1 through 4.4.4).

4.4 Conformance inspection. Quality conformance inspection for device class M shall be in accordance with MIL-STD-883 (see 3.1 herein) and as specified herein. Inspections to be performed for device class M shall be those specified in method 5005 of MIL-STD-883 and herein for groups A, B, C, D, and E inspections (see 4.4.1 through 4.4.4). Technology conformance inspection for classes Q and V shall be in accordance with MIL-I-38535, or as specified in the QM plan, including groups A, B, C, D, and E inspections and as specified herein except where option 2 of MIL-I-38535 permits alternate in-line control testing.

4.4.1 Group A inspection.

a. Tests shall be as specified in table IIA herein.

b. For device class M, subgroups 7 and 8 tests shall be sufficient to verify the functionality of the device. For device classes Q and V, subgroups 7 and 8 shall include verifying the functionality of the device.

c. Subgroup 4 ( $C_{IN}$ ,  $C_{OUT}$  measurement) shall be measured only for the initial test and after process or design changes which may affect capacitance. A minimum sample size of 5 devices with zero rejects shall be required.

4.4.2 Group C inspection. The group C inspection end-point electrical parameters shall be as specified in table II herein.

STANDARD MICROCIRCUIT DRAWING DEFENSE ELECTRONICS SUPPLY CENTER DAYTON, OHIO 45444	SIZE <b>A</b>		5962-95716
		REVISION LEVEL	SHEET 10

TABLE IIA. Electrical test requirements.

Test requirements	Subgroups (in accordance with MIL-STD-883, TM 5005, table I)	Subgroups (in accordance with MIL-I-38535, table III)	
	Device class M	Device class Q	Device class V
Interim electrical parameters (see 4.2)	1,7,9	1,7,9	1,7,9
Final electrical parameters (see 4.2)	1,2,3,7,8,9, 1/ 10,11	1,2,3,7,8, 1/ 9,10,11	1,2,3,7,8,2/ 9,10,11 3/
Group A test requirements (see 4.4)	1,2,3,4,7,8,9 10,11	1,2,3,4,7,8, 9,10,11	1,2,3,4,7, 8,9,10,11
Group C end-point electrical parameters (see 4.4)	1,2,3,7,8,9 10,11	1,2,3,7,8,9 10,11	1,2,3,7,8,9 10,11 3/
Group D end-point electrical parameters (see 4.4)	1,7,9	1,7,9	1,7,9
Group E end-point electrical parameters (see 4.4)	1,7,9	1,7,9	1,7,9

1/ PDA applies to subgroup 1 and 7.

2/ PDA applies to subgroups 1,7 and delta's.

3/ Delta limits as specified in Table IIB herein shall be required where specified and the delta values shall be completed with reference to the zero hour electrical parameters (See Table I).

Table IIB. Delta Limits

Parameter	Symbol	Delta Limits
Standby power supply current	ICCSB	+/- 2.0 $\mu$ A
Output leakage current	IOZL, IOZH	+/- 2.0 $\mu$ A
Input leakage current	IIH, IIL	+/- 200 nA

4.4.2.1 Additional criteria for device class M. Steady-state life test conditions, method 1005 of MIL-STD-883:

- a. Test condition A, B, C, or D. The test circuit shall be maintained by the manufacturer under document revision level control and shall be made available to the preparing or acquiring activity upon request. The test circuit shall specify the inputs, outputs, biases, and power dissipation, as applicable, in accordance with the intent specified in test method 1005.
- b.  $T_A = +125^\circ\text{C}$ , minimum.
- c. Test duration: 1,000 hours, except as permitted by method 1005 of MIL-STD-883.

STANDARD MICROCIRCUIT DRAWING DEFENSE ELECTRONICS SUPPLY CENTER DAYTON, OHIO 45444	SIZE <b>A</b>		5962-95716
		REVISION LEVEL	SHEET 11

4.4.2.2 Additional criteria for device classes Q and V. The steady-state life test duration, test condition and test temperature, or approved alternatives shall be as specified in the device manufacturer's QM plan in accordance with MIL-I-38535. The test circuit shall be maintained under document revision level control by the device manufacturer's TRB, in accordance with MIL-I-38535, and shall be made available to the acquiring or preparing activity upon request. The test circuit shall specify the inputs, outputs, biases, and power dissipation, as applicable, in accordance with the intent specified in test method 1005.

4.4.3 Group D inspection. The group D inspection end-point electrical parameters shall be as specified in table IIA herein.

4.4.4 Group E inspection. Group E inspection is required only for parts intended to be marked as radiation hardness assured (see 3.5 herein). RHA levels for device classes Q and V shall be M, D, L, R, F, G, and H and for device class M shall be M and D.

- a. End-point electrical parameters shall be as specified in table IIA herein.
- b. For device class M, the devices shall be subjected to radiation hardness assured tests as specified in MIL-I-38535, appendix A, for the RHA level being tested. For device classes Q and V, the devices or test vehicle shall be subjected to radiation hardness assured tests as specified in MIL-I-38535 for the RHA level being tested. All device classes must meet the postirradiation end-point electrical parameter limits as defined in table I at  $T_A = +25^{\circ}\text{C} \pm 5^{\circ}\text{C}$ , after exposure, to the subgroups specified in table IIA herein.
- c. When specified in the purchase order or contract, a copy of the RHA delta limits shall be supplied.

5. PACKAGING

5.1 Packaging requirements. The requirements for packaging shall be in accordance with MIL-STD-883 (see 3.1 herein) for device class M and MIL-I-38535 for device classes Q and V.

6. NOTES

6.1 Intended use. Microcircuits conforming to this drawing are intended for use for Government microcircuit applications (original equipment), design applications, and logistics purposes.

6.1.1 Replaceability. Microcircuits covered by this drawing will replace the same generic device covered by a contractor-prepared specification or drawing.

6.1.2 Substitutability. Device class Q devices will replace device class M devices.

6.2 Configuration control of SMD's. All proposed changes to existing SMD's will be coordinated with the users of record for the individual documents. This coordination will be accomplished in accordance with MIL-STD-973 using DD Form 1692, Engineering Change Proposal.

6.3 Record of users. Military and industrial users shall inform Defense Electronics Supply Center when a system application requires configuration control and which SMD's are applicable to that system. DESC will maintain a record of users and this list will be used for coordination and distribution of changes to the drawings. Users of drawings covering microelectronic devices (FSC 5962) should contact DESC-EC, telephone (513) 296-6047.

6.4 Comments. Comments on this drawing should be directed to DESC-EC, Dayton, Ohio 45444-5270, or telephone (513) 296-5377.

6.5 Abbreviations, symbols, and definitions. The abbreviations, symbols, and definitions used herein are defined in MIL-I-38535 and MIL-STD-1331.

STANDARD MICROCIRCUIT DRAWING DEFENSE ELECTRONICS SUPPLY CENTER DAYTON, OHIO 45444	SIZE <b>A</b>		5962-95716
		REVISION LEVEL	SHEET 12

6.6 One part - one part number system. The one part - one part number system described below has been developed to allow for transitions between identical generic devices covered by the three major microcircuit requirements documents (MIL-H-38534, MIL-I-38535, and 1.2.1 of MIL-STD-883) without the necessity for the generation of unique PIN's. The three military requirements documents represent different class levels, and previously when a device manufacturer upgraded military product from one class level to another, the benefits of the upgraded product were unavailable to the Original Equipment Manufacturer (OEM), that was contractually locked into the original unique PIN. By establishing a one part number system covering all three documents, the OEM can acquire to the highest class level available for a given generic device to meet system needs without modifying the original contract parts selection criteria.

<u>Military documentation format</u>	<u>Example PIN under new system</u>	<u>Manufacturing source listing</u>	<u>Document listing</u>
New MIL-H-38534 Standard Microcircuit Drawings	5962-XXXXZZ(H or K)YY	QML-38534	MIL-BUL-103
New MIL-I-38535 Standard Microcircuit Drawings	5962-XXXXZZ(Q or V)YY	QML-38535	MIL-BUL-103
New 1.2.1 of MIL-STD-883 Standard Microcircuit Drawings	5962-XXXXZZ(M)YY	MIL-BUL-103	MIL-BUL-103

6.7 Sources of supply.

6.7.1 Sources of supply for device classes Q and V. Sources of supply for device classes Q and V are listed in QML-38535. The vendors listed in QML-38535 have submitted a certificate of compliance (see 3.6 herein) to DESC-EC and have agreed to this drawing.

6.7.2 Approved sources of supply for device class M. Approved sources of supply for class M are listed in MIL-BUL-103. The vendors listed in MIL-BUL-103 have agreed to this drawing and a certificate of compliance (see 3.6 herein) has been submitted to and accepted by DESC-EC.

<b>STANDARD MICROCIRCUIT DRAWING DEFENSE ELECTRONICS SUPPLY CENTER DAYTON, OHIO 45444</b>	<b>SIZE A</b>		<b>5962-95716</b>
		<b>REVISION LEVEL</b>	<b>SHEET 13</b>

## STANDARD MICROCIRCUIT DRAWING SOURCE APPROVAL BULLETIN

DATE:95-12-28

Approved sources of supply for SMD 5962-95716 are listed below for immediate acquisition only and shall be added to MIL-BUL-103 during the next revision. MIL-BUL-103 will be revised to include the addition or deletion of sources. The vendors listed below have agreed to this drawing and a certificate of compliance has been submitted to and accepted by DESC-EC. This bulletin is superseded by the next dated revision of MIL-BUL-103.

Standard microcircuit drawing PIN	Vendor CAGE number	Vendor similar PIN 1/
5962-9571601VRC	34371	MD82C82/7

1/ Caution. Do not use this number for item acquisition. Items acquired to this number may not satisfy the performance requirements of this drawing.

Vendor CAGE  
number

34371

Vendor name  
and address

Harris Semiconductor  
P.O. Box 883  
Melbourne FL 32902-0883

The information contained herein is disseminated for convenience only and the Government assumes no liability whatsoever for any inaccuracies in this information bulletin.