

REVISIONS			
LTR	DESCRIPTION	DATE (YR-MO-DA)	APPROVED
A	Changes in accordance with NOR 5962-R107-98.	98-05-11	R. MONNIN
B	Changes to 1.2.4, 1.3, and 1.4. Update boilerplate. - rrp	99-06-07	R. MONNIN
C	Add 3.1.1 and appendix A. - ro	99-09-14	R. MONNIN
D	Update boilerplate and update die plot in appendix A. - rrp	01-07-27	R. MONNIN
E	Add low dose rate footnote under 1.5 and Table I. Add sentence for clarification to footnote 2/ as specified under Table I. Under 1.5, delete Neutron test, Latchup test, and corresponding footnotes. Under 4.4.4, delete Accelerated aging test, Neutron testing, and Dose rate induced latchup testing paragraphs. Delete 6.7, Additional information paragraph. - ro	07-03-15	R. HEBER



REV																				
SHEET																				
REV	E	E	E	E	E															
SHEET	15	16	17	18	19															
REV STATUS	REV			E	E	E	E	E	E	E	E	E	E	E	E	E	E	E	E	
OF SHEETS	SHEET			1	2	3	4	5	6	7	8	9	10	11	12	13	14			

PMIC N/A	PREPARED BY RAJESH PITHADIA	DEFENSE SUPPLY CENTER COLUMBUS COLUMBUS, OHIO 43218-3990 http://www.dsc.dla.mil																	
STANDARD MICROCIRCUIT DRAWING THIS DRAWING IS AVAILABLE FOR USE BY ALL DEPARTMENTS AND AGENCIES OF THE DEPARTMENT OF DEFENSE AMSC N/A	CHECKED BY RAJESH PITHADIA																		
	APPROVED BY MICHAEL FRYE	MICROCIRCUIT, LINEAR, RADIATION HARDENED, UNCOMPENSATED, HIGH SLEW RATE, OPERATIONAL AMPLIFIER, MONOLITHIC SILICON																	
	DRAWING APPROVAL DATE 95-11-09																		
	REVISION LEVEL E		SIZE A	CAGE CODE 67268	5962-95685														
		SHEET	1 OF 19																

1. SCOPE

1.1 Scope. This drawing documents two product assurance class levels consisting of high reliability (device classes Q and M) and space application (device class V). A choice of case outlines and lead finishes are available and are reflected in the Part or Identifying Number (PIN). When available, a choice of Radiation Hardness Assurance (RHA) levels is reflected in the PIN.

1.2 PIN. The PIN is as shown in the following example:

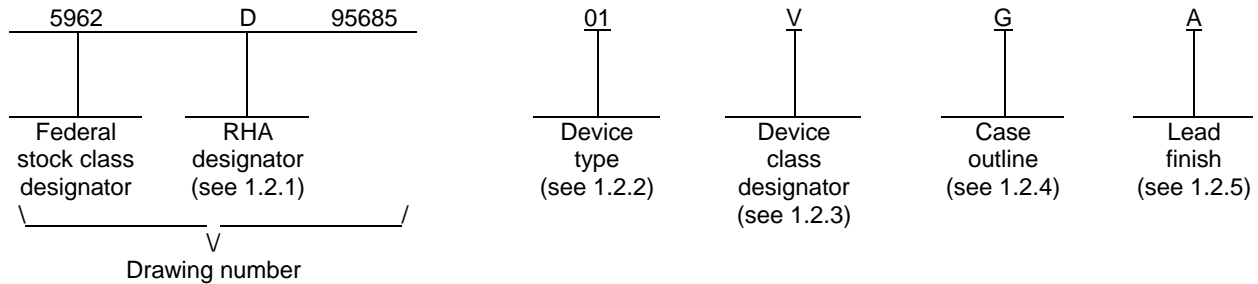

1.2.1 RHA designator. Device classes Q and V RHA marked devices meet the MIL-PRF-38535 specified RHA levels and are marked with the appropriate RHA designator. Device class M RHA marked devices meet the MIL-PRF-38535, appendix A specified RHA levels and are marked with the appropriate RHA designator. A dash (-) indicates a non-RHA device.

1.2.2 Device type(s). The device type(s) identify the circuit function as follows:

<u>Device type</u>	<u>Generic number</u>	<u>Circuit function</u>
01	HS-2520RH	Radiation hardened, D.I., uncompensated high slew rate, operational amplifier

1.2.3 Device class designator. The device class designator is a single letter identifying the product assurance level as follows:

<u>Device class</u>	<u>Device requirements documentation</u>
M	Vendor self-certification to the requirements for MIL-STD-883 compliant, non-JAN class level B microcircuits in accordance with MIL-PRF-38535, appendix A
Q or V	Certification and qualification to MIL-PRF-38535

1.2.4 Case outline(s). The case outline(s) are as designated in MIL-STD-1835 and as follows:

<u>Outline letter</u>	<u>Descriptive designator</u>	<u>Terminals</u>	<u>Package style</u>
G	MACY1-X8	8	Can
P	GDIP1-T8 or CDIP2-T8	8	Dual-in-line

1.2.5 Lead finish. The lead finish is as specified in MIL-PRF-38535 for device classes Q and V or MIL-PRF-38535, appendix A for device class M.

STANDARD MICROCIRCUIT DRAWING DEFENSE SUPPLY CENTER COLUMBUS COLUMBUS, OHIO 43218-3990	SIZE A		5962-95685
		REVISION LEVEL E	SHEET 2

1.3 Absolute maximum ratings. 1/

Supply voltage between V+ and V-	40 V
Differential input voltage	15 V
Voltage at either input terminal	V+ to V-
Peak output current	50 mA
Junction temperature (T _J)	+175°C
Storage temperature range	-65°C to +150°C
Maximum package power dissipation (P _D) at T _A = +125°C:	
Case G	0.31 W <u>2/</u>
Case P	0.44 W <u>2/</u>
Lead temperature (soldering, 10 seconds)	+275°C
Thermal resistance, junction-to-case (θ _{JC}):	
Case G	70°C/W
Case P	30°C/W
Thermal resistance, junction-to-ambient (θ _{JA}):	
Case G	160°C/W
Case P	115°C/W

1.4 Recommended operating conditions.

Positive supply voltage (V+)	+15 V
Negative supply voltage (V-)	-15 V
Ambient operating temperature range (T _A)	-55°C to +125°C

1.5 Radiation features.

Maximum total dose available (dose rate = 50 - 300 rads (Si)/s) 10 Krads (Si) 3/

2. APPLICABLE DOCUMENTS

2.1 Government specification, standards, and handbooks. The following specification, standards, and handbooks form a part of this drawing to the extent specified herein. Unless otherwise specified, the issues of these documents are those cited in the solicitation or contract.

DEPARTMENT OF DEFENSE SPECIFICATION

MIL-PRF-38535 - Integrated Circuits, Manufacturing, General Specification for.

DEPARTMENT OF DEFENSE STANDARDS

MIL-STD-883 - Test Method Standard Microcircuits.
 MIL-STD-1835 - Interface Standard Electronic Component Case Outlines.

1/ Stresses above the absolute maximum rating may cause permanent damage to the device. Extended operation at the maximum levels may degrade performance and affect reliability.

2/ If device power exceeds package dissipation capability, provide heat sinking or derate linearly (the derating is based on θ_{JA}) at the following rate:

Case outline G	6.3 mW/°C
Case outline P	8.7 mW/°C

3/ These parts may be dose rate sensitive in a space environment and may demonstrate enhanced low dose rate effects. Radiation end point limits for the noted parameters are guaranteed only for the conditions specified in MIL-STD-883, method 1019, condition A.

STANDARD MICROCIRCUIT DRAWING DEFENSE SUPPLY CENTER COLUMBUS COLUMBUS, OHIO 43218-3990	SIZE A		5962-95685
		REVISION LEVEL E	SHEET 3

DEPARTMENT OF DEFENSE HANDBOOKS

- MIL-HDBK-103 - List of Standard Microcircuit Drawings.
- MIL-HDBK-780 - Standard Microcircuit Drawings.

(Copies of these documents are available online at <http://assist.daps.dla.mil/quicksearch/> or <http://assist.daps.dla.mil> or from the Standardization Document Order Desk, 700 Robbins Avenue, Building 4D, Philadelphia, PA 19111-5094.)

2.2 Order of precedence. In the event of a conflict between the text of this drawing and the references cited herein, the text of this drawing takes precedence. Nothing in this document, however, supersedes applicable laws and regulations unless a specific exemption has been obtained.

3. REQUIREMENTS

3.1 Item requirements. The individual item requirements for device classes Q and V shall be in accordance with MIL-PRF-38535 and as specified herein or as modified in the device manufacturer's Quality Management (QM) plan. The modification in the QM plan shall not affect the form, fit, or function as described herein. The individual item requirements for device class M shall be in accordance with MIL-PRF-38535, appendix A for non-JAN class level B devices and as specified herein.

3.1.1 Microcircuit die. For the requirements of microcircuit die, see appendix A to this document.

3.2 Design, construction, and physical dimensions. The design, construction, and physical dimensions shall be as specified in MIL-PRF-38535 and herein for device classes Q and V or MIL-PRF-38535, appendix A and herein for device class M.

3.2.1 Case outlines. The case outlines shall be in accordance with 1.2.4 herein.

3.2.2 Terminal connections. The terminal connections shall be as specified on figure 1.

3.2.3 Radiation exposure circuit. The radiation exposure circuit shall be as specified on figure 2.

3.3 Electrical performance characteristics and postirradiation parameter limits. Unless otherwise specified herein, the electrical performance characteristics and postirradiation parameter limits are as specified in table I and shall apply over the full ambient operating temperature range.

3.4 Electrical test requirements. The electrical test requirements shall be the subgroups specified in table IIA. The electrical tests for each subgroup are defined in table I.

3.5 Marking. The part shall be marked with the PIN listed in 1.2 herein. In addition, the manufacturer's PIN may also be marked. For packages where marking of the entire SMD PIN number is not feasible due to space limitations, the manufacturer has the option of not marking the "5962-" on the device. For RHA product using this option, the RHA designator shall still be marked. Marking for device classes Q and V shall be in accordance with MIL-PRF-38535. Marking for device class M shall be in accordance with MIL-PRF-38535, appendix A.

3.5.1 Certification/compliance mark. The certification mark for device classes Q and V shall be a "QML" or "Q" as required in MIL-PRF-38535. The compliance mark for device class M shall be a "C" as required in MIL-PRF-38535, appendix A.

3.6 Certificate of compliance. For device classes Q and V, a certificate of compliance shall be required from a QML-38535 listed manufacturer in order to supply to the requirements of this drawing (see 6.6.1 herein). For device class M, a certificate of compliance shall be required from a manufacturer in order to be listed as an approved source of supply in MIL-HDBK-103 (see 6.6.2 herein). The certificate of compliance submitted to DSCC-VA prior to listing as an approved source of supply for this drawing shall affirm that the manufacturer's product meets, for device classes Q and V, the requirements of MIL-PRF-38535 and herein or for device class M, the requirements of MIL-PRF-38535, appendix A and herein.

3.7 Certificate of conformance. A certificate of conformance as required for device classes Q and V in MIL-PRF-38535 or for device class M in MIL-PRF-38535, appendix A shall be provided with each lot of microcircuits delivered to this drawing.

3.8 Notification of change for device class M. For device class M, notification to DSCC-VA of change of product (see 6.2 herein) involving devices acquired to this drawing is required for any change that affects this drawing.

STANDARD MICROCIRCUIT DRAWING DEFENSE SUPPLY CENTER COLUMBUS COLUMBUS, OHIO 43218-3990	SIZE A		5962-95685
		REVISION LEVEL E	SHEET 4

TABLE I. Electrical performance characteristics.

Test	Symbol	Conditions ^{1/} -55°C ≤ T _A ≤ +125°C unless otherwise specified	Device type	Group A subgroups	Limits		Unit
					Min	Max	
Input offset voltage	V _{IO}	V _{CM} = 0 V M, D <u>2/ 3/</u>	01	1	-8	8	mV
				2, 3	-10	10	
				1	-10	10	
Input bias current	+I _B	V _{CM} = 0 V, +R _S = 100 kΩ, -R _S = 100 Ω M, D <u>2/ 3/</u>	01	1	-200	200	nA
				2, 3	-400	400	
				1	-700	700	
	-I _B	V _{CM} = 0 V, +R _S = 100 Ω, -R _S = 100 kΩ M, D <u>2/ 3/</u>	01	1	-200	200	
				2, 3	-400	400	
				1	-700	700	
Input offset current	I _{IO}	V _{CM} = 0 V, +R _S = 100 kΩ, -R _S = 100 kΩ M, D <u>2/ 3/</u>	01	1	-25	25	nA
				2, 3	-50	50	
				1	-50	50	
Common mode range	+CMR	V ₊ = 5 V, V ₋ = -25 V M, D <u>2/ 3/</u>	01	1	+10		V
				2, 3	+10		
				1	+10		
	-CMR	V ₊ = 25 V, V ₋ = -5 V M, D <u>2/ 3/</u>	01	1		-10	
				2, 3		-10	
				1		-10	
Large signal voltage gain	+A _{VOL}	V _{OUT} = 0 V and +10 V, R _L = 2 kΩ M, D <u>2/ 3/</u>	01	4	10		kV/V
				5, 6	7.5		
				4	6.5		
	-A _{VOL}	V _{OUT} = 0 V and -10 V, R _L = 2 kΩ M, D <u>2/ 3/</u>	01	4	10		
				5, 6	7.5		
				4	6.5		

See footnotes at end of table.

STANDARD MICROCIRCUIT DRAWING DEFENSE SUPPLY CENTER COLUMBUS COLUMBUS, OHIO 43218-3990	SIZE A		5962-95685
		REVISION LEVEL E	SHEET 5

TABLE I. Electrical performance characteristics – Continued.

Test	Symbol	Conditions <u>1/</u> -55°C ≤ T _A ≤ +125°C unless otherwise specified	Device type	Group A subgroups	Limits		Unit
					Min	Max	
Common mode rejection ratio	+CMRR	$\Delta V_{CM} = +10\text{ V}$, +V = +5 V, -V = -25 V, V _{OUT} = -10 V	01	1	80		dB
				2, 3	80		
				1	75		
	-CMRR	$\Delta V_{CM} = -10\text{ V}$, +V = +25 V, -V = -5 V, V _{OUT} = +10 V	01	1	80		
				2, 3	80		
				1	75		
Output voltage swing	+V _{OUT}	R _L = 2 kΩ	01	4	10		V
				5, 6	10		
				4	10		
	-V _{OUT}	R _L = 2 kΩ	01	4		-10	
				5, 6		-10	
				4		-10	
Output current	+I _{OUT}	V _{OUT} = -10 V	01	4	10		mA
				5, 6	7.5		
				4	7.5		
	-I _{OUT}	V _{OUT} = +10 V	01	4		-10	
				5, 6		-7.5	
				4		-7.5	
Quiescent power supply current	+I _{CC}	I _{OUT} = 0 mA	01	1		6	mA
				2, 3		6.5	
				1		6.5	
	-I _{CC}	I _{OUT} = 0 mA	01	1	-6		
				2, 3	-6.5		
				1	-6.5		

See footnotes at end of table.

STANDARD MICROCIRCUIT DRAWING DEFENSE SUPPLY CENTER COLUMBUS COLUMBUS, OHIO 43218-3990	SIZE A		5962-95685
		REVISION LEVEL E	SHEET 6

TABLE I. Electrical performance characteristics – Continued.

Test	Symbol	Conditions <u>1/</u> -55°C ≤ T _A ≤ +125°C unless otherwise specified	Device type	Group A subgroups	Limits		Unit
					Min	Max	
Power supply rejection ratio	+PSRR	$\Delta V_{SUP} = 10\text{ V}$, $+V = +20\text{ V}$, $-V = -15\text{ V}$, $+V = +10\text{ V}$, $-V = -15\text{ V}$	01	1, 2, 3	80		dB
				1	76		
	-PSRR	$\Delta V_{SUP} = 10\text{ V}$, $+V = +15\text{ V}$, $-V = -20\text{ V}$, $+V = +15\text{ V}$, $-V = -10\text{ V}$		1, 2, 3	80		
				1	76		
Offset voltage <u>4/</u> adjustment	+V _{IO} ADJ		01	1, 2, 3	V _{IO} - 1		mV
				1	V _{IO} - 1		
	-V _{IO} ADJ			1, 2, 3	V _{IO} + 1		
				1	V _{IO} + 1		
Differential input <u>5/ 6/</u> resistance	R _{IN}	V _{CM} = 0 V, C _{COMP} = 0 pF	01	4	50		MΩ
Gain bandwidth <u>5/ 6/</u> product	GBWP	V _{OUT} = 200 mV, f _O = 10 kHz, C _{COMP} = 0 pF	01	4	10		MHz
		V _{OUT} = 200 mV, f _O = 1 MHz, C _{COMP} = 0 pF			10		
Full power <u>5/ 6/ 7/</u> bandwidth	FPBW	V _{PEAK} = 10 V, C _{COMP} = 0 pF	01	4	1.6		MHz
Minimum closed <u>5/ 6/</u> loop stable gain	CLSG	R _L = 2 kΩ, C _L = 50 pF, C _{COMP} = 0 pF	01	4, 5, 6	+3		V/V
Quiescent <u>5/ 6/ 8/</u> power consumption	P _C	V _{OUT} = 0 V, I _{OUT} = 0 mA, C _{COMP} = 0 pF	01	1, 2, 3		195	mW

See footnotes at end of table.

STANDARD MICROCIRCUIT DRAWING DEFENSE SUPPLY CENTER COLUMBUS COLUMBUS, OHIO 43218-3990	SIZE A		5962-95685
		REVISION LEVEL E	SHEET 7

TABLE I. Electrical performance characteristics – Continued.

Test	Symbol	Conditions <u>1/</u> -55°C ≤ T _A ≤ +125°C unless otherwise specified	Device type	Group A subgroups	Limits		Unit
					Min	Max	
Slew rate	+SR	V _{OUT} = -5 V to +5 V <u>6/</u> see figure 3 <div style="text-align: right; border: 1px solid black; padding: 2px;">M, D <u>2/ 3/</u></div>	01	9	100		V/μs
				10, 11	84		
				9	84		
	-SR	V _{OUT} = +5 V to -5 V <u>6/</u> see figure 3 <div style="text-align: right; border: 1px solid black; padding: 2px;">M, D <u>2/ 3/</u></div>		9	100		
				10, 11	84		
				9	84		
Rise and fall time	t _r	V _{OUT} = 0 to +200 mV, <u>6/</u> see figure 3 <div style="text-align: right; border: 1px solid black; padding: 2px;">M, D <u>2/ 3/</u></div>	01	9		50	ns
				10, 11		55	
				9		55	
	-t _f	V _{OUT} = 0 to -200 mV, <u>6/</u> see figure 3 <div style="text-align: right; border: 1px solid black; padding: 2px;">M, D <u>2/ 3/</u></div>		9		50	
				10, 11		55	
				9		55	
Overshoot	+OS	V _{OUT} = 0 to +200 mV, <u>6/</u> see figure 3 <div style="text-align: right; border: 1px solid black; padding: 2px;">M, D <u>2/ 3/</u></div>	01	9		40	%
				10, 11		45	
				9		45	
	-OS	V _{OUT} = 0 to -200 mV, <u>6/</u> see figure 3 <div style="text-align: right; border: 1px solid black; padding: 2px;">M, D <u>2/ 3/</u></div>		9		40	
				10, 11		45	
				9		45	

- 1/ Supply voltage (V_S) = ±15 V, source resistance (R_S) = 100 Ω, load resistance (R_L) = 500 kΩ, V_{OUT} = 0 V.
- 2/ Devices supplied to this drawing meet all levels M, D of irradiation. However, this device is only tested at the 'D' level. Pre and Post irradiation values are identical unless otherwise specified in table I. When performing post irradiation electrical measurements for any RHA level, T_A = +25°C.
- 3/ These parts may be dose rate sensitive in a space environment and may demonstrate enhanced low dose rate effects. Radiation end point limits for the noted parameters are guaranteed only for the conditions specified in MIL-STD-883, method 1019, condition A.
- 4/ Offset adjustment range is [V_{IO} (measured) ± 1 mV] minimum referred to output. This test is for functionality only to assure adjustment through 0 V.
- 5/ If not tested, shall be guaranteed to the limits specified in table I.
- 6/ Supply voltage (V_S) = ±15 V, source resistance (R_S) = 50 Ω, load resistance (R_L) = 2 kΩ, load capacitance (C_L) = 50 pF, A_{VCL} = +3 V/V.
- 7/ Full power bandwidth guarantee based on slew rate measurement using FPBW = slew rate / (2πV_{PEAK}).
- 8/ Quiescent power consumption based upon quiescent supply current test maximum (no load on outputs).

STANDARD MICROCIRCUIT DRAWING DEFENSE SUPPLY CENTER COLUMBUS COLUMBUS, OHIO 43218-3990	SIZE A		5962-95685
		REVISION LEVEL E	SHEET 8

Device type	01
Case outlines	G and P
Terminal number	Terminal symbol
1	BAL
2	-IN
3	+IN
4	V-
5	BAL
6	OUT
7	V+
8	COMP

FIGURE 1. Terminal connections.

STANDARD MICROCIRCUIT DRAWING DEFENSE SUPPLY CENTER COLUMBUS COLUMBUS, OHIO 43218-3990	SIZE A		5962-95685
		REVISION LEVEL E	SHEET 9

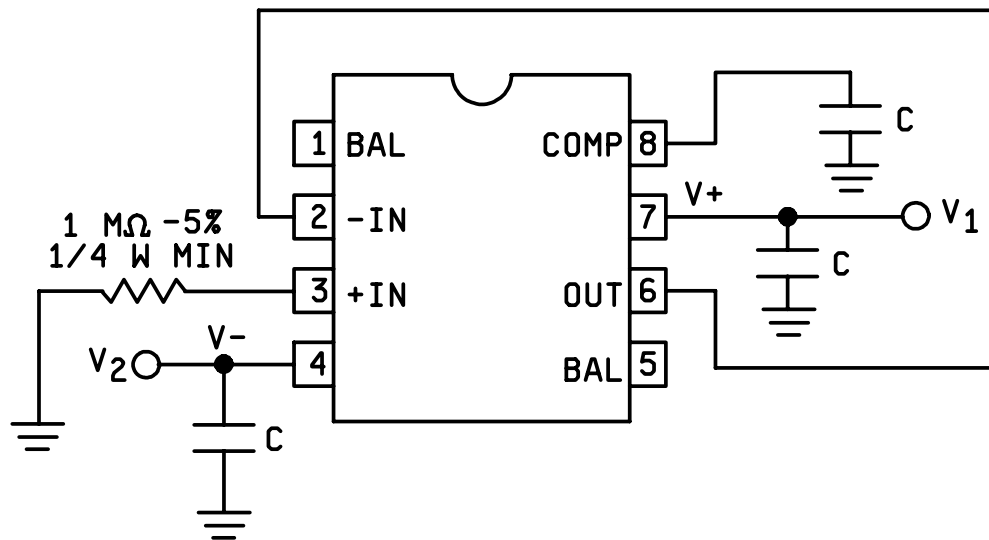

NOTE:

1. $V_1 = +15\text{ V} \pm 10\%$, $V_2 = -15\text{ V} \pm 10\%$, $C = 0.1\ \mu\text{F} \pm 10\%$.

FIGURE 2. Radiation exposure circuit.

**STANDARD
MICROCIRCUIT DRAWING**
DEFENSE SUPPLY CENTER COLUMBUS
COLUMBUS, OHIO 43218-3990

SIZE
A

REVISION LEVEL
E

5962-95685

SHEET
10

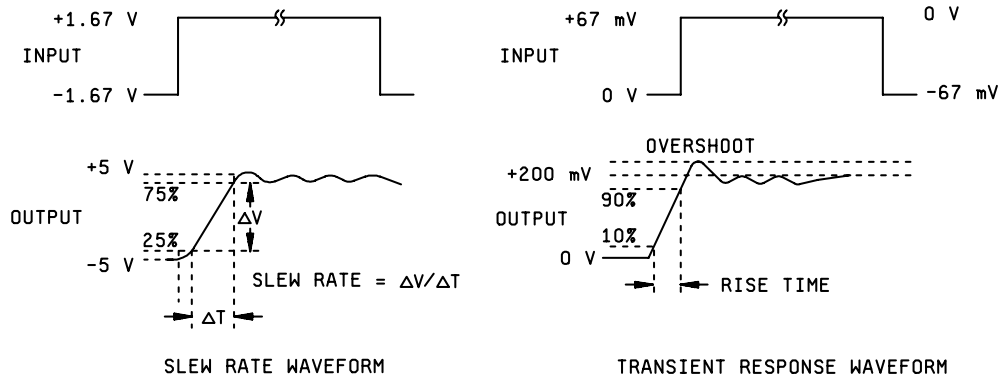
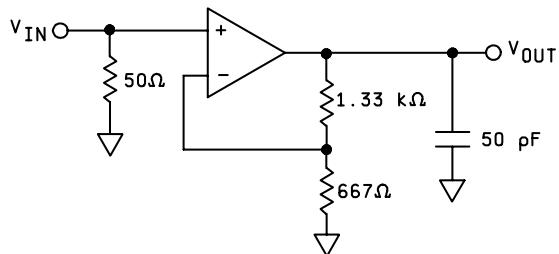

NOTE:

Measured on both positive and negative transitions. Capacitance at compensation pin should be minimized.

FIGURE 3. Test circuit and timing waveforms.

STANDARD MICROCIRCUIT DRAWING DEFENSE SUPPLY CENTER COLUMBUS COLUMBUS, OHIO 43218-3990	SIZE A		5962-95685
		REVISION LEVEL E	SHEET 11

3.9 Verification and review for device class M. For device class M, DSCC, DSCC's agent, and the acquiring activity retain the option to review the manufacturer's facility and applicable required documentation. Offshore documentation shall be made available onshore at the option of the reviewer.

3.10 Microcircuit group assignment for device class M. Device class M devices covered by this drawing shall be in microcircuit group number 49 (see MIL-PRF-38535, appendix A).

4. VERIFICATION

4.1 Sampling and inspection. For device classes Q and V, sampling and inspection procedures shall be in accordance with MIL-PRF-38535 or as modified in the device manufacturer's Quality Management (QM) plan. The modification in the QM plan shall not affect the form, fit, or function as described herein. For device class M, sampling and inspection procedures shall be in accordance with MIL-PRF-38535, appendix A.

4.2 Screening. For device classes Q and V, screening shall be in accordance with MIL-PRF-38535, and shall be conducted on all devices prior to qualification and technology conformance inspection. For device class M, screening shall be in accordance with method 5004 of MIL-STD-883, and shall be conducted on all devices prior to quality conformance inspection.

4.2.1 Additional criteria for device class M.

- a. Burn-in test, method 1015 of MIL-STD-883.
 - (1) Test condition A, B, C, or D. The test circuit shall be maintained by the manufacturer under document revision level control and shall be made available to the preparing or acquiring activity upon request. The test circuit shall specify the inputs, outputs, biases, and power dissipation, as applicable, in accordance with the intent specified in method 1015.
 - (2) $T_A = +125^{\circ}\text{C}$, minimum.
- b. Interim and final electrical test parameters shall be as specified in table IIA herein.

4.2.2 Additional criteria for device classes Q and V.

- a. The burn-in test duration, test condition and test temperature, or approved alternatives shall be as specified in the device manufacturer's QM plan in accordance with MIL-PRF-38535. The burn-in test circuit shall be maintained under document revision level control of the device manufacturer's Technology Review Board (TRB) in accordance with MIL-PRF-38535 and shall be made available to the acquiring or preparing activity upon request. The test circuit shall specify the inputs, outputs, biases, and power dissipation, as applicable, in accordance with the intent specified in method 1015 of MIL-STD-883.
- b. Interim and final electrical test parameters shall be as specified in table IIA herein.
- c. Additional screening for device class V beyond the requirements of device class Q shall be as specified in MIL-PRF-38535, appendix B.

4.3 Qualification inspection for device classes Q and V. Qualification inspection for device classes Q and V shall be in accordance with MIL-PRF-38535. Inspections to be performed shall be those specified in MIL-PRF-38535 and herein for groups A, B, C, D, and E inspections (see 4.4.1 through 4.4.4).

4.4 Conformance inspection. Technology conformance inspection for classes Q and V shall be in accordance with MIL-PRF-38535 including groups A, B, C, D, and E inspections and as specified herein. Quality conformance inspection for device class M shall be in accordance with MIL-PRF-38535, appendix A and as specified herein. Inspections to be performed for device class M shall be those specified in method 5005 of MIL-STD-883 and herein for groups A, B, C, D, and E inspections (see 4.4.1 through 4.4.4).

4.4.1 Group A inspection.

- a. Tests shall be as specified in table IIA herein.
- b. Subgroups 7 and 8 in table I, method 5005 of MIL-STD-883 shall be omitted.

STANDARD MICROCIRCUIT DRAWING DEFENSE SUPPLY CENTER COLUMBUS COLUMBUS, OHIO 43218-3990	SIZE A		5962-95685
		REVISION LEVEL E	SHEET 12

TABLE IIA. Electrical test requirements.

Test requirements	Subgroups (in accordance with MIL-STD-883, method 5005, table I)	Subgroups (in accordance with MIL-PRF-38535, table III)	
	Device class M	Device class Q	Device class V
Interim electrical parameters (see 4.2)	1, 9	1, 9	1, 9
Final electrical parameters (see 4.2)	1, 2, 3, 4, 5, 6, <u>1/</u> 9, 10, 11	1, 2, 3, 4, <u>1/</u> 5, 6, 9, 10, 11	1, 2, 3, 4, <u>1/ 2/</u> 5, 6, 9, 10, 11
Group A test requirements (see 4.4)	1, 2, 3, 4, 5, 6, 9, 10, 11	1, 2, 3, 4, 5, 6, 9, 10, 11	1, 2, 3, 4, 5, 6, 9, 10, 11
Group C end-point electrical parameters (see 4.4)	1, 2, 3, 4, 5, 6, 9, 10, 11	1, 2, 3, 4, 5, 6, 9, 10, 11	1, 2, 3, 4, <u>2/</u> 5, 6, 9, 10, 11
Group D end-point electrical parameters (see 4.4)	1, 4, 9	1, 4, 9	1, 4, 9
Group E end-point electrical parameters (see 4.4)	1, 4, 9	1, 4, 9	1, 4, 9

1/ PDA applies to subgroup 1.

2/ Delta limits (see table IIB) shall be required and the delta values shall be computed with reference to the zero hour electrical parameters (see Table I).

Table IIB. Burn-in and group C delta parameters ($T_A = +25^\circ\text{C}$).

Parameter	Delta limits
V_{IO}	± 2.0 mV
IBIAS	± 50 nA

4.4.2 Group C inspection. The group C inspection end-point electrical parameters shall be as specified in table IIA herein.

4.4.2.1 Additional criteria for device class M. Steady-state life test conditions, method 1005 of MIL-STD-883:

- a. Test condition A, B, C, or D. The test circuit shall be maintained by the manufacturer under document revision level control and shall be made available to the preparing or acquiring activity upon request. The test circuit shall specify the inputs, outputs, biases, and power dissipation, as applicable, in accordance with the intent specified in method 1005 of MIL-STD-883.
- b. $T_A = +125^\circ\text{C}$, minimum.
- c. Test duration: 1,000 hours, except as permitted by method 1005 of MIL-STD-883.

4.4.2.2 Additional criteria for device classes Q and V. The steady-state life test duration, test condition and test temperature, or approved alternatives shall be as specified in the device manufacturer's QM plan in accordance with MIL-PRF-38535. The test circuit shall be maintained under document revision level control by the device manufacturer's TRB in accordance with MIL-PRF-38535 and shall be made available to the acquiring or preparing activity upon request. The test circuit shall specify the inputs, outputs, biases, and power dissipation, as applicable, in accordance with the intent specified in method 1005 of MIL-STD-883.

4.4.3 Group D inspection. The group D inspection end-point electrical parameters shall be as specified in table IIA herein.

STANDARD MICROCIRCUIT DRAWING DEFENSE SUPPLY CENTER COLUMBUS COLUMBUS, OHIO 43218-3990	SIZE A		5962-95685
		REVISION LEVEL E	SHEET 13

4.4.4 Group E inspection. Group E inspection is required only for parts intended to be marked as radiation hardness assured (see 3.5 herein). RHA levels for device classes M, Q and V shall be as specified in MIL-PRF-38535. End-point electrical parameters shall be as specified in table IIA herein.

4.4.4.1 Total dose irradiation testing. Total dose irradiation testing shall be performed in accordance with MIL-STD-883 method 1019 condition A and as specified herein.

4.4.4.2 Dose rate burnout. When required by the customer, test shall be performed on devices, SEC, or approved test structures at technology qualifications and after any design or process changes which may effect the RHA capability of the process. Dose rate burnout shall be performed in accordance with test method 1023 of MIL-STD-883 and as specified herein.

5. PACKAGING

5.1 Packaging requirements. The requirements for packaging shall be in accordance with MIL-PRF-38535 for device classes Q and V or MIL-PRF-38535, appendix A for device class M.

6. NOTES

6.1 Intended use. Microcircuits conforming to this drawing are intended for use for Government microcircuit applications (original equipment), design applications, and logistics purposes.

6.1.1 Replaceability. Microcircuits covered by this drawing will replace the same generic device covered by a contractor prepared specification or drawing.

6.1.2 Substitutability. Device class Q devices will replace device class M devices.

6.2 Configuration control of SMD's. All proposed changes to existing SMD's will be coordinated with the users of record for the individual documents. This coordination will be accomplished using DD Form 1692, Engineering Change Proposal.

6.3 Record of users. Military and industrial users should inform Defense Supply Center Columbus (DSCC) when a system application requires configuration control and which SMD's are applicable to that system. DSCC will maintain a record of users and this list will be used for coordination and distribution of changes to the drawings. Users of drawings covering microelectronic devices (FSC 5962) should contact DSCC-VA, telephone (614) 692-0544.

6.4 Comments. Comments on this drawing should be directed to DSCC-VA, Columbus, Ohio 43218-3990, or telephone (614) 692-0547.

6.5 Abbreviations, symbols, and definitions. The abbreviations, symbols, and definitions used herein are defined in MIL-PRF-38535 and MIL-HDBK-1331.

6.6 Sources of supply.

6.6.1 Sources of supply for device classes Q and V. Sources of supply for device classes Q and V are listed in QML-38535. The vendors listed in QML-38535 have submitted a certificate of compliance (see 3.6 herein) to DSCC-VA and have agreed to this drawing.

6.6.2 Approved sources of supply for device class M. Approved sources of supply for class M are listed in MIL-HDBK-103. The vendors listed in MIL-HDBK-103 have agreed to this drawing and a certificate of compliance (see 3.6 herein) has been submitted to and accepted by DSCC-VA.

STANDARD MICROCIRCUIT DRAWING DEFENSE SUPPLY CENTER COLUMBUS COLUMBUS, OHIO 43218-3990	SIZE A		5962-95685
		REVISION LEVEL E	SHEET 14

APPENDIX A
APPENDIX A FORMS A PART OF SMD 5962-95685

A.1 SCOPE

A.1.1 Scope. This appendix establishes minimum requirements for microcircuit die to be supplied under the Qualified Manufacturers List (QML) Program. QML microcircuit die meeting the requirements of MIL-PRF-38535 and the manufacturers approved QM plan for use in monolithic microcircuits, multi-chip modules (MCMs), hybrids, electronic modules, or devices using chip and wire designs in accordance with MIL-PRF-38534 are specified herein. Two product assurance classes consisting of military high reliability (device class Q) and space application (device class V) are reflected in the Part or Identification Number (PIN). When available, a choice of Radiation Hardness Assurance (RHA) levels are reflected in the PIN.

A.1.2 PIN. The PIN is as shown in the following example:

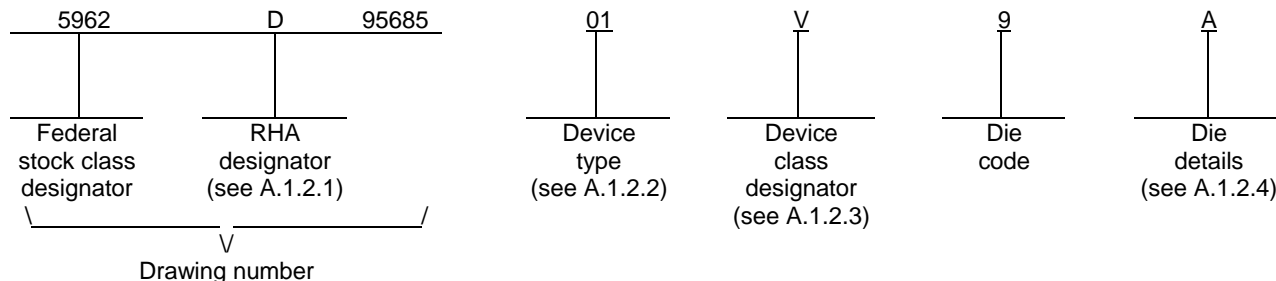

A.1.2.1 RHA designator. Device classes Q and V RHA identified die meet the MIL-PRF-38535 specified RHA levels. A dash (-) indicates a non-RHA die.

A.1.2.2 Device type(s). The device type(s) identify the circuit function as follows:

<u>Device type</u>	<u>Generic number</u>	<u>Circuit function</u>
01	HS-2520RH	Radiation hardened DI uncompensated high slew rate operational amplifier

A.1.2.3 Device class designator.

<u>Device class</u>	<u>Device requirements documentation</u>
Q or V	Certification and qualification to the die requirements of MIL-PRF-38535

STANDARD MICROCIRCUIT DRAWING DEFENSE SUPPLY CENTER COLUMBUS COLUMBUS, OHIO 43218-3990	SIZE A		5962-95685
		REVISION LEVEL E	SHEET 15

APPENDIX A
APPENDIX A FORMS A PART OF SMD 5962-95685

A.1.2.4 Die details. The die details designation is a unique letter which designates the die's physical dimensions, bonding pad location(s) and related electrical function(s), interface materials, and other assembly related information, for each product and variant supplied to this appendix.

A.1.2.4.1 Die physical dimensions.

<u>Die type</u>	<u>Figure number</u>
01	A-1

A.1.2.4.2 Die bonding pad locations and electrical functions.

<u>Die type</u>	<u>Figure number</u>
01	A-1

A.1.2.4.3 Interface materials.

<u>Die type</u>	<u>Figure number</u>
01	A-1

A.1.2.4.4 Assembly related information.

<u>Die type</u>	<u>Figure number</u>
01	A-1

A.1.3 Absolute maximum ratings. See paragraph 1.3 herein for details.

A.1.4 Recommended operating conditions. See paragraph 1.4 herein for details.

STANDARD MICROCIRCUIT DRAWING DEFENSE SUPPLY CENTER COLUMBUS COLUMBUS, OHIO 43218-3990	SIZE A		5962-95685
		REVISION LEVEL E	SHEET 16

APPENDIX A
APPENDIX A FORMS A PART OF SMD 5962-95685

A.2 APPLICABLE DOCUMENTS.

A.2.1 Government specification, standards, and handbooks. The following specification, standards, and handbooks form a part of this drawing to the extent specified herein. Unless otherwise specified, the issues of these documents are those cited in the solicitation or contract.

DEPARTMENT OF DEFENSE SPECIFICATION

MIL-PRF-38535 - Integrated Circuits, Manufacturing, General Specification for.

DEPARTMENT OF DEFENSE STANDARD

MIL-STD-883 - Test Method Standard Microcircuits.

DEPARTMENT OF DEFENSE HANDBOOKS

MIL-HDBK-103 - List of Standard Microcircuit Drawings.

MIL-HDBK-780 - Standard Microcircuit Drawings.

(Copies of these documents are available online at <http://assist.daps.dla.mil/quicksearch/> or <http://assist.daps.dla.mil> or from the Standardization Document Order Desk, 700 Robbins Avenue, Building 4D, Philadelphia, PA 19111-5094.)

A.2.2 Order of precedence. In the event of a conflict between the text of this drawing and the references cited herein, the text of this drawing takes precedence. Nothing in this document, however, supersedes applicable laws and regulations unless a specific exemption has been obtained.

A.3 REQUIREMENTS

A.3.1 Item requirements. The individual item requirements for device classes Q and V shall be in accordance with MIL-PRF-38535 and as specified herein or as modified in the device manufacturer's Quality Management (QM) plan. The modification in the QM plan shall not affect the form, fit, or function as described herein.

A.3.2 Design, construction and physical dimensions. The design, construction, and physical dimensions shall be as specified in MIL-PRF-38535 and herein and the manufacturer's QM plan for device classes Q and V.

A.3.2.1 Die physical dimensions. The die physical dimensions shall be as specified in A.1.2.4.1 and on figure A-1.

A.3.2.2 Die bonding pad locations and electrical functions. The die bonding pad locations and electrical functions shall be as specified in A.1.2.4.2 and on figure A-1.

A.3.2.3 Interface materials. The interface materials for the die shall be as specified in A.1.2.4.3 and on figure A-1.

A.3.2.4 Assembly related information. The assembly related information shall be as specified in A.1.2.4.4 and on figure A-1.

A.3.2.5 Radiation exposure circuit. The radiation exposure circuit shall be as defined in paragraph 3.2.3 herein.

A.3.3 Electrical performance characteristics and post-irradiation parameter limits. Unless otherwise specified herein, the electrical performance characteristics and post-irradiation parameter limits are as specified in table I of the body of this document.

A.3.4 Electrical test requirements. The wafer probe test requirements shall include functional and parametric testing sufficient to make the packaged die capable of meeting the electrical performance requirements in table I.

A.3.5 Marking. As a minimum, each unique lot of die, loaded in single or multiple stack of carriers, for shipment to a customer, shall be identified with the wafer lot number, the certification mark, the manufacturer's identification and the PIN listed in A.1.2 herein. The certification mark shall be a "QML" or "Q" as required by MIL-PRF-38535.

STANDARD MICROCIRCUIT DRAWING DEFENSE SUPPLY CENTER COLUMBUS COLUMBUS, OHIO 43218-3990	SIZE A		5962-95685
		REVISION LEVEL E	SHEET 17

APPENDIX A
APPENDIX A FORMS A PART OF SMD 5962-95685

A.3.6 Certification of compliance. For device classes Q and V, a certificate of compliance shall be required from a QML-38535 listed manufacturer in order to supply to the requirements of this drawing (see A.6.4 herein). The certificate of compliance submitted to DSCC-VA prior to listing as an approved source of supply for this appendix shall affirm that the manufacturer's product meets, for device classes Q and V, the requirements of MIL-PRF-38535 and the requirements herein.

A.3.7 Certificate of conformance. A certificate of conformance as required for device classes Q and V in MIL-PRF-38535 shall be provided with each lot of microcircuit die delivered to this drawing.

A.4 VERIFICATION

A.4.1 Sampling and inspection. For device classes Q and V, die sampling and inspection procedures shall be in accordance with MIL-PRF-38535 or as modified in the device manufacturer's Quality Management (QM) plan. The modifications in the QM plan shall not affect the form, fit, or function as described herein.

A.4.2 Screening. For device classes Q and V, screening shall be in accordance with MIL-PRF-38535, and as defined in the manufacturer's QM plan. As a minimum, it shall consist of:

- a. Wafer lot acceptance for class V product using the criteria defined in MIL-STD-883, method 5007.
- b. 100% wafer probe (see paragraph A.3.4 herein).
- c. 100% internal visual inspection to the applicable class Q or V criteria defined in MIL-STD-883, method 2010 or the alternate procedures allowed in MIL-STD-883, method 5004.

A.4.3 Conformance inspection.

A.4.3.1 Group E inspection. Group E inspection is required only for parts intended to be identified as radiation assured (see A.3.5 herein). RHA levels for device classes Q and V shall be as specified in MIL-PRF-38535. End point electrical testing of packaged die shall be as specified in table II herein. Group E tests and conditions are as specified in paragraphs 4.4.4, 4.4.4.1, and 4.4.4.2 herein.

A.5 DIE CARRIER

A.5.1 Die carrier requirements. The requirements for the die carrier shall be accordance with the manufacturer's QM plan or as specified in the purchase order by the acquiring activity. The die carrier shall provide adequate physical, mechanical and electrostatic protection.

A.6 NOTES

A.6.1 Intended use. Microcircuit die conforming to this drawing are intended for use in microcircuits built in accordance with MIL-PRF-38535 or MIL-PRF-38534 for government microcircuit applications (original equipment), design applications, and logistics purposes.

A.6.2 Comments. Comments on this appendix should be directed to DSCC-VA, Columbus, Ohio, 43218-3990 or telephone (614)-692-0547.

A.6.3 Abbreviations, symbols, and definitions. The abbreviations, symbols, and definitions used herein are defined in MIL-PRF-38535 and MIL-HDBK-1331.

A.6.4 Sources of supply for device classes Q and V. Sources of supply for device classes Q and V are listed in QML-38535. The vendors listed within QML-38535 have submitted a certificate of compliance (see A.3.6 herein) to DSCC-VA and have agreed to this drawing.

STANDARD MICROCIRCUIT DRAWING DEFENSE SUPPLY CENTER COLUMBUS COLUMBUS, OHIO 43218-3990	SIZE A		5962-95685
		REVISION LEVEL E	SHEET 18

APPENDIX A
 APPENDIX A FORMS A PART OF SMD 5962-95685

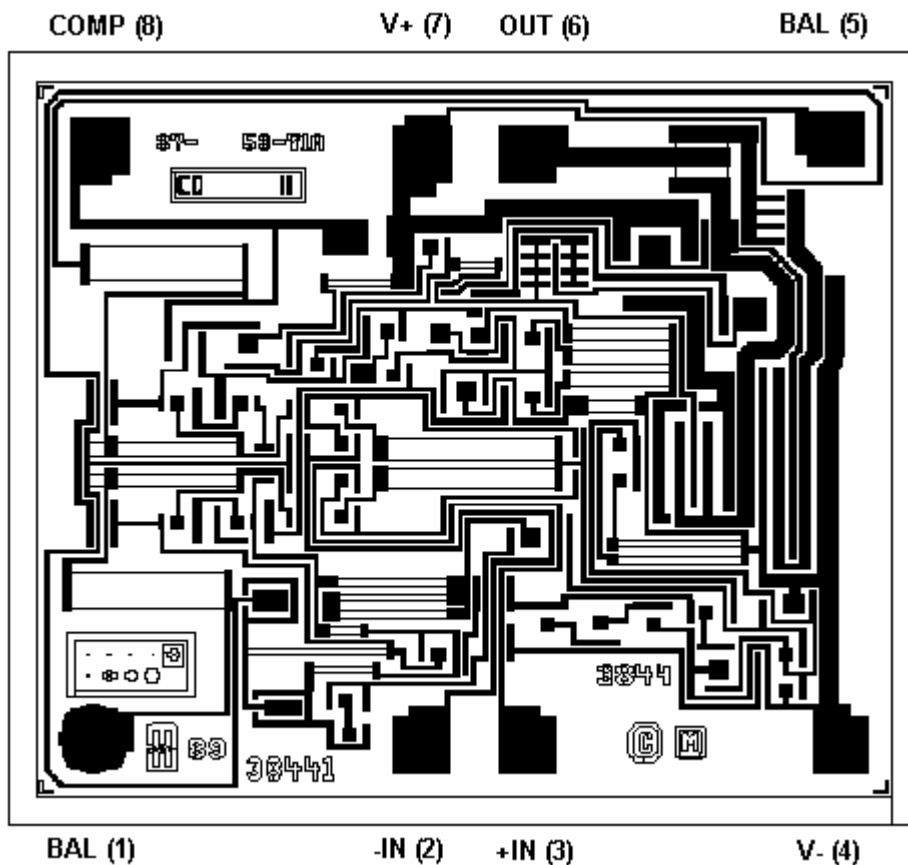

NOTE: Pad numbers reflect terminal numbers when placed in case outlines G and P (see figure 1).

Die physical dimensions.

Die size: 1700 microns x 1440 microns.

Die thickness: 19 mils ± 1 mils.

Interface materials.

Top metallization: Al 16.0 kÅ ± 2 kÅ

Backside metallization: None

Glassivation.

Type: Nitride (Si₃N₄) over Silox (SiO₂, 5% Phos)

Silox Thickness: 12.0 kÅ ± 2 kÅ

Nitride Thickness: 3.5 kÅ ± 1.5 kÅ

Substrate: DI (dielectric isolation)

Assembly related information.

Substrate potential: Unbiased

Special assembly instructions: None

FIGURE A-1. Die bonding pad locations and electrical functions.

STANDARD MICROCIRCUIT DRAWING DEFENSE SUPPLY CENTER COLUMBUS COLUMBUS, OHIO 43218-3990	SIZE A		5962-95685
		REVISION LEVEL E	SHEET 19

STANDARD MICROCIRCUIT DRAWING BULLETIN

DATE: 07-03-15

Approved sources of supply for SMD 5962-95685 are listed below for immediate acquisition information only and shall be added to MIL-HDBK-103 and QML-38535 during the next revision. MIL-HDBK-103 and QML-38535 will be revised to include the addition or deletion of sources. The vendors listed below have agreed to this drawing and a certificate of compliance has been submitted to and accepted by DSCC-VA. This information bulletin is superseded by the next dated revision of MIL-HDBK-103 and QML-38535. DSCC maintains an online database of all current sources of supply at <http://www.dscclia.mil/Programs/Smcr/>.

Standard microcircuit drawing PIN <u>1/</u>	Vendor CAGE number	Vendor similar PIN <u>2/</u>
5962D9568501VGA	<u>3/</u>	HS2-2520RH-Q
5962D9568501VPA	<u>3/</u>	HS7-2520RH-Q
5962D9568501VPC	<u>3/</u>	HS7B-2520RH-Q
5962D9568501V9A	<u>3/</u>	HS0-2520RH-Q

- 1/ The lead finish shown for each PIN representing a hermetic package is the most readily available from the manufacturer listed for that part. If the desired lead finish is not listed contact the vendor to determine its availability.
- 2/ Caution. Do not use this number for item acquisition. Items acquired to this number may not satisfy the performance requirements of this drawing.
- 3/ Not available from an approved source of supply. The last known supplier is listed below.

Vendor CAGE
number

34371

Vendor name
and address

Intersil Corporation
1001 Murphy Ranch Road
Milpitas, CA 95035-6803
Point of contact: 2401 Palm Bay Blvd.
P.O. Box 883
Melbourne, FL 32902-0883

The information contained herein is disseminated for convenience only and the Government assumes no liability whatsoever for any inaccuracies in the information bulletin.