

REVISIONS			
LTR	DESCRIPTION	DATE (YR-MO-DA)	APPROVED
A	Drawing updated to reflect current requirements. -ro	02-02-05	R. MONNIN
B	Five year review requirement. -rrp	09-11-03	C. SAFFLE

REV																				
SHEET																				
REV	B																			
SHEET	15																			
REV STATUS	REV	B	B	B	B	B	B	B	B	B	B	B	B	B	B	B	B	B	B	B
OF SHEETS	SHEET	1	2	3	4	5	6	7	8	9	10	11	12	13	14					

PMIC N/A	PREPARED BY GREG A. PITZ	DEFENSE SUPPLY CENTER COLUMBUS COLUMBUS, OHIO 43218-3990 http://www.dsc.dla.mil																	
STANDARD MICROCIRCUIT DRAWING THIS DRAWING IS AVAILABLE FOR USE BY ALL DEPARTMENTS AND AGENCIES OF THE DEPARTMENT OF DEFENSE AMSC N/A	CHECKED BY RAJESH R. PITHADIA																		
	APPROVED BY MICHAEL A. FRYE	MICROCIRCUIT, LINEAR, CURRENT FEEDBACK AMPLIFIER, ULTRA HIGH SPEED, OUTPUT CLAMPING, MONOLITHIC SILICON																	
	DRAWING APPROVAL DATE 94-08-08																		
	REVISION LEVEL B		SIZE A	CAGE CODE 67268	5962-94677														
		SHEET 1 OF 15																	

1. SCOPE

1.1 Scope. This drawing documents two product assurance class levels consisting of high reliability (device classes Q and M) and space application (device class V). A choice of case outlines and lead finishes are available and are reflected in the Part or Identifying Number (PIN). When available, a choice of Radiation Hardness Assurance (RHA) levels is reflected in the PIN.

1.2 PIN. The PIN is as shown in the following example:

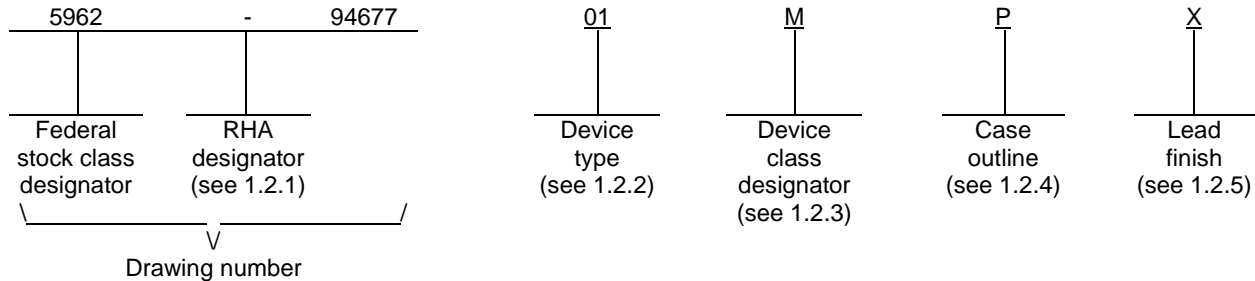

1.2.1 RHA designator. Device classes Q and V RHA marked devices meet the MIL-PRF-38535 specified RHA levels and are marked with the appropriate RHA designator. Device class M RHA marked devices meet the MIL-PRF-38535, appendix A specified RHA levels and are marked with the appropriate RHA designator. A dash (-) indicates a non-RHA device.

1.2.2 Device type(s). The device type(s) identify the circuit function as follows:

<u>Device type</u>	<u>Generic number</u>	<u>Circuit function</u>
01	HFA1130	Output clamping ultra high speed current feedback amplifier

1.2.3 Device class designator. The device class designator is a single letter identifying the product assurance level as follows:

<u>Device class</u>	<u>Device requirements documentation</u>
M	Vendor self-certification to the requirements for MIL-STD-883 compliant, non-JAN class level B microcircuits in accordance with MIL-PRF-38535, appendix A
Q or V	Certification and qualification to MIL-PRF-38535

1.2.4 Case outline(s). The case outline(s) are as designated in MIL-STD-1835 and as follows:

<u>Outline letter</u>	<u>Descriptive designator</u>	<u>Terminals</u>	<u>Package style</u>
P	GDIP1-T8 or CDIP2-T8	8	Dual-in-line
2	CQCC1-N20	20	Square leadless chip carrier

1.2.5 Lead finish. The lead finish is as specified in MIL-PRF-38535 for device classes Q and V or MIL-PRF-38535, appendix A for device class M.

STANDARD MICROCIRCUIT DRAWING DEFENSE SUPPLY CENTER COLUMBUS COLUMBUS, OHIO 43218-3990	SIZE A		5962-94677
		REVISION LEVEL B	SHEET 2

1.3 Absolute maximum ratings. 1/

Voltage between V+ and V-	12 V
Differential input voltage	5 V
Voltage at either input terminal	V+ to V-
Voltage at V _H or V _L terminal	(V+) +2 V to (V-) -2 V
Output current (50% duty cycle)	±55 mA
Maximum power dissipation at +75°C:	
Case outline P	0.87 W
Case outline 2	1.33 W
Power dissipation derating factor above +75°C:	
Case outline P	8.7 mW/°C
Case outline 2	13.3 mW/°C
Junction temperature (T _J)	+175°C
Storage temperature range	-65°C to +150°C
Thermal resistance, junction-to-case (θ _{JC})	See MIL-STD-1835
Lead temperature (soldering 10 seconds)	+300°C

1.4 Recommended operating conditions.

Operating supply voltage (±V _S)	±5 V
Load resistance (R _L)	≥ 50 Ω
Ambient operating temperature range (T _A)	-55°C to +125°C

2. APPLICABLE DOCUMENTS

2.1 Government specification, standards, and handbooks. The following specification, standards, and handbooks form a part of this drawing to the extent specified herein. Unless otherwise specified, the issues of these documents are those cited in the solicitation or contract.

DEPARTMENT OF DEFENSE SPECIFICATION

MIL-PRF-38535 - Integrated Circuits, Manufacturing, General Specification for.

DEPARTMENT OF DEFENSE STANDARDS

MIL-STD-883 - Test Method Standard Microcircuits.
MIL-STD-1835 - Interface Standard Electronic Component Case Outlines.

DEPARTMENT OF DEFENSE HANDBOOKS

MIL-HDBK-103 - List of Standard Microcircuit Drawings.
MIL-HDBK-780 - Standard Microcircuit Drawings.

(Copies of these documents are available online at <http://assist.daps.dla.mil/quicksearch/> or from the Standardization Document Order Desk, 700 Robbins Avenue, Building 4D, Philadelphia, PA 19111-5094.)

2.2 Order of precedence. In the event of a conflict between the text of this drawing and the references cited herein, the text of this drawing takes precedence. Nothing in this document, however, supersedes applicable laws and regulations unless a specific exemption has been obtained.

1/ Stresses above the absolute maximum rating may cause permanent damage to the device. Extended operation at the maximum levels may degrade performance and affect reliability.

STANDARD MICROCIRCUIT DRAWING DEFENSE SUPPLY CENTER COLUMBUS COLUMBUS, OHIO 43218-3990	SIZE A		5962-94677
		REVISION LEVEL B	SHEET 3

3. REQUIREMENTS

3.1 Item requirements. The individual item requirements for device classes Q and V shall be in accordance with MIL-PRF-38535 and as specified herein or as modified in the device manufacturer's Quality Management (QM) plan. The modification in the QM plan shall not affect the form, fit, or function as described herein. The individual item requirements for device class M shall be in accordance with MIL-PRF-38535, appendix A for non-JAN class level B devices and as specified herein.

3.2 Design, construction, and physical dimensions. The design, construction, and physical dimensions shall be as specified in MIL-PRF-38535 and herein for device classes Q and V or MIL-PRF-38535, appendix A and herein for device class M.

3.2.1 Case outlines. The case outlines shall be in accordance with 1.2.4 herein.

3.2.2 Terminal connections. The terminal connections shall be as specified on figure 1.

3.2.3 Test circuit. The test circuit shall be as specified on figure 2.

3.2.4 Test waveform. The test waveform shall be as specified on figure 3.

3.3 Electrical performance characteristics and postirradiation parameter limits. Unless otherwise specified herein, the electrical performance characteristics and postirradiation parameter limits are as specified in table I and shall apply over the full ambient operating temperature range.

3.4 Electrical test requirements. The electrical test requirements shall be the subgroups specified in table II. The electrical tests for each subgroup are defined in table I.

3.5 Marking. The part shall be marked with the PIN listed in 1.2 herein. In addition, the manufacturer's PIN may also be marked. For packages where marking of the entire SMD PIN number is not feasible due to space limitations, the manufacturer has the option of not marking the "5962-" on the device. For RHA product using this option, the RHA designator shall still be marked. Marking for device classes Q and V shall be in accordance with MIL-PRF-38535. Marking for device class M shall be in accordance with MIL-PRF-38535, appendix A.

3.5.1 Certification/compliance mark. The certification mark for device classes Q and V shall be a "QML" or "Q" as required in MIL-PRF-38535. The compliance mark for device class M shall be a "C" as required in MIL-PRF-38535, appendix A.

3.6 Certificate of compliance. For device classes Q and V, a certificate of compliance shall be required from a QML-38535 listed manufacturer in order to supply to the requirements of this drawing (see 6.6.1 herein). For device class M, a certificate of compliance shall be required from a manufacturer in order to be listed as an approved source of supply in MIL-HDBK-103 (see 6.6.2 herein). The certificate of compliance submitted to DSCC-VA prior to listing as an approved source of supply for this drawing shall affirm that the manufacturer's product meets, for device classes Q and V, the requirements of MIL-PRF-38535 and herein or for device class M, the requirements of MIL-PRF-38535, appendix A and herein.

3.7 Certificate of conformance. A certificate of conformance as required for device classes Q and V in MIL-PRF-38535 or for device class M in MIL-PRF-38535, appendix A shall be provided with each lot of microcircuits delivered to this drawing.

3.8 Notification of change for device class M. For device class M, notification to DSCC-VA of change of product (see 6.2 herein) involving devices acquired to this drawing is required for any change that affects this drawing.

3.9 Verification and review for device class M. For device class M, DSCC, DSCC's agent, and the acquiring activity retain the option to review the manufacturer's facility and applicable required documentation. Offshore documentation shall be made available onshore at the option of the reviewer.

3.10 Microcircuit group assignment for device class M. Device class M devices covered by this drawing shall be in microcircuit group number 49 (see MIL-PRF-38535, appendix A).

STANDARD MICROCIRCUIT DRAWING DEFENSE SUPPLY CENTER COLUMBUS COLUMBUS, OHIO 43218-3990	SIZE A		5962-94677
		REVISION LEVEL B	SHEET 4

TABLE I. Electrical performance characteristics.

Test	Symbol	Conditions -55°C ≤ T _A ≤ +125°C V _{SUPPLY} = ±5 V unless otherwise specified	Group A subgroups	Device type	Limits		Unit
					Min	Max	
Input offset voltage <u>1/</u>	V _{IO}	V _{CM} = 0 V	1	All	-6	6	mV
			2, 3		-10	10	
Common mode rejection ratio <u>1/</u>	CMRR	ΔV _{CM} = ±2 V, V ₊ = 3 V, V ₋ = -7 V, V ₊ = 7 V, V ₋ = -3 V	1	All	40		dB
			2, 3		38		
Power supply rejection ratio <u>1/</u>	PSRRP	ΔV _{SUPPLY} = ±1.25 V, V ₊ = 6.25 V, V ₋ = -5 V, V ₋ = 3.75 V, V ₊ = -5 V	1	All	45		dB
			2, 3		42		
	PSRRN	ΔV _{SUPPLY} = ±1.25 V, V ₊ = 5 V, V ₋ = -6.25 V, V ₊ = 5 V, V ₋ = -3.75 V	1		45		
			2, 3		42		
Non-inverting input (+IN) current <u>1/</u>	I _{BSP}	V _{CM} = 0 V	1	All	-40	40	μA
			2, 3		-65	65	
+IN current common mode sensitivity <u>1/</u>	CMS _{IBP}	ΔV _{CM} = ±2 V, V ₊ = 3 V, V ₋ = -7 V, V ₊ = 7 V, V ₋ = -3 V	1	All		40	μA/V
			2, 3			50	
+IN resistance <u>1/</u>	+R _{IN}	<u>2/</u>	1	All	25		kΩ
			2, 3		20		
Inverting input (-IN) current <u>1/</u>	I _{BSN}	V _{CM} = 0 V	1	All	-50	50	μA
			2, 3		-75	75	
-IN current common mode sensitivity <u>1/</u>	CMS _{IBN}	ΔV _{CM} = ±2 V, V ₊ = 3 V, V ₋ = -7 V, V ₊ = 7 V, V ₋ = -3 V	1	All		7	μA/V
			2, 3			10	

See footnotes at end of table.

STANDARD MICROCIRCUIT DRAWING DEFENSE SUPPLY CENTER COLUMBUS COLUMBUS, OHIO 43218-3990	SIZE A		5962-94677
		REVISION LEVEL B	SHEET 5

TABLE I. Electrical performance characteristics - Continued.

Test	Symbol	Conditions -55°C ≤ T _A ≤ +125°C V _{SUPPLY} = ±5 V unless otherwise specified	Group A subgroups	Device type	Limits		Unit				
					Min	Max					
-IN current power supply sensitivity 1/	PPSS _{IBN}	ΔV _{SUPPLY} = ±1.25 V, V ₊ = 6.25 V, V ₋ = -5 V, V ₊ = 3.75 V, V ₋ = -5 V	1	All		15	μA/V				
			2, 3			27					
	NPSS _{IBN}	ΔV _{SUPPLY} = ±1.25 V, V ₊ = 5 V, V ₋ = -6.25 V, V ₊ = 5 V, V ₋ = -3.75 V	1			15					
			2, 3			27					
Output voltage swing 1/	VOP ₁₀₀	V _{IN} = -3.5 V, A _V = -1, R _L = 100 Ω	1	All	3		V				
			2, 3		2.5						
	VON ₁₀₀	V _{IN} = +3.5 V, A _V = -1, R _L = 100 Ω	1					-3			
			2, 3					-2.5			
	VOP ₅₀	V _{IN} = -3.0 V, A _V = -1, R _L = 50 Ω	1, 2			2.5					
			3			1.5					
	VON ₅₀	V _{IN} = +3.0 V, A _V = -1, R _L = 50 Ω	1, 2					-2.5			
			3					-1.5			
	Output current 1/	+I _{OUT}	3/		1, 2	All		50		mA	
					3			30			
		-I _{OUT}			1, 2						-50
					3						-30

See footnotes at end of table.

STANDARD MICROCIRCUIT DRAWING DEFENSE SUPPLY CENTER COLUMBUS COLUMBUS, OHIO 43218-3990	SIZE A		5962-94677
		REVISION LEVEL B	SHEET 6

TABLE I. Electrical performance characteristics - Continued.

Test	Symbol	Conditions -55°C ≤ T _A ≤ +125°C V _{SUPPLY} = ±5 V unless otherwise specified	Group A subgroups	Device type	Limits		Unit
					Min	Max	
Quiescent power supply current <u>1/</u>	I _{CC}	R _L = 100 Ω	1	All	14	26	mA
			2, 3			33	
	I _{EE}	R _L = 100 Ω	1		-26	-14	
			2, 3		-33		
Clamp accuracy <u>1/</u>	V _H CLMP	A _V = -1, V _{IN} = -2 V, V _H = 1 V	1	All	-125	125	mV
			2, 3		-200	200	
	V _L CLMP	A _V = -1, V _{IN} = +2 V, V _L = -1 V	1		-125	125	
			2, 3		-200	200	
Clamp input current <u>1/</u>	V _H BIAS	V _H = 1 V	1	All		200	μA
			2, 3			300	
	V _L BIAS	V _L = -1 V	1		-200		
			2, 3		-300		
-3 dB Bandwidth <u>1/ 4/</u>	BW(-1)	A _V = -1, R _F = 430 Ω, <u>5/</u> V _{OUT} = 200 mV _{P-P}	4	All	300		MHz
	BW(+1)	A _V = +1, R _F = 510 Ω, <u>5/</u> V _{OUT} = 200 mV _{P-P}			550		
	BW(+2)	A _V = +2, <u>5/</u> V _{OUT} = 200 mV _{P-P}			350		
Gain flatness <u>4/ 5/</u>	GF30	A _V = +2, R _F = 510 Ω, V _{OUT} = 200 mV _{P-P} , f ≤ 30 MHz	4	All		±0.04	dB
	GF50	A _V = +2, R _F = 510 Ω, V _{OUT} = 200 mV _{P-P} , f ≤ 50 MHz				±0.10	
	GF100	A _V = +2, R _F = 510 Ω, V _{OUT} = 200 mV _{P-P} , f ≤ 100 MHz				±0.30	

See footnotes at end of table.

STANDARD MICROCIRCUIT DRAWING DEFENSE SUPPLY CENTER COLUMBUS COLUMBUS, OHIO 43218-3990	SIZE A		5962-94677
		REVISION LEVEL B	SHEET 7

TABLE I. Electrical performance characteristics - Continued.

Test	Symbol	Conditions -55°C ≤ T _A ≤ +125°C V _{SUPPLY} = ±5 V unless otherwise specified	Group A subgroups	Device type	Limits		Unit
					Min	Max	
Slew rate <u>4/ 5/</u>	+SR(+1)	A _V = +1, R _F = 510 Ω, <u>6/</u> V _{OUT} = 5 V _{P-P}	4	All	1200		V/μs
	-SR(+1)	A _V = +1, R _F = 510 Ω, <u>6/</u> V _{OUT} = 5 V _{P-P}			1100		
	+SR(+2)	A _V = +2, <u>6/</u> V _{OUT} = 5 V _{P-P}			1650		
	-SR(+2)	A _V = +2, <u>6/</u> V _{OUT} = 5 V _{PP}			1500		
Rise and fall time <u>4/ 5/</u>	T _R	A _V = +2, <u>6/</u> V _{OUT} = 0.5 V _{P-P}	9	All		1	ns
	T _F	A _V = +2, <u>6/</u> V _{OUT} = 0.5 V _{P-P}				1	
Overshoot <u>4/ 5/</u>	+OS	A _V = +2, <u>7/</u> V _{OUT} = 0.5 V _{P-P}	4	All		25	%
	-OS	A _V = +2, <u>7/</u> V _{OUT} = 0.5 V _{P-P}				20	
Settling time <u>4/ 5/</u>	TS(0.1)	A _V = +2, R _F = 510 Ω, V _{OUT} = 2 V to 0 V, to 0.1%	9	All		20	ns
	TS(.05)	A _V = +2, R _F = 510 Ω, <u>6/</u> V _{OUT} = 2 V to 0 V, to 0.05%				33	
2nd harmonic distortion <u>4/</u>	HD2(30)	A _V = +2, V _{OUT} = 2 V _{P-P} , f = 30 MHz	4	All		-48	dBc
	HD2(50)	A _V = +2, V _{OUT} = 2 V _{P-P} , f = 50 MHz				-45	
	HD2(100)	A _V = +2, V _{OUT} = 2 V _{P-P} , f = 100 MHz				-35	

See footnotes at end of table.

STANDARD MICROCIRCUIT DRAWING DEFENSE SUPPLY CENTER COLUMBUS COLUMBUS, OHIO 43218-3990	SIZE A		5962-94677
		REVISION LEVEL B	SHEET 8

TABLE I. Electrical performance characteristics - Continued.

Test	Symbol	Conditions -55°C ≤ T _A ≤ +125°C V _{SUPPLY} = ±5 V unless otherwise specified	Group A subgroups	Device type	Limits		Unit
					Min	Max	
3rd harmonic distortion	4/ HD3(30)	A _V = +2, V _{OUT} = 2 V _{P-P} , f = 30 MHz	4	All		-65	dBc
	HD3(50)	A _V = +2, V _{OUT} = 2 V _{P-P} , f = 50 MHz				-60	
	HD3(100)	A _V = +2, V _{OUT} = 2 V _{P-P} , f = 100 MHz				-40	

1/ A_V = +1, R_F = 510 Ω, R_{SOURCE} = 0 Ω, R_L = 100 Ω, V_{OUT} = 0 V unless otherwise specified. See figure 2.

2/ Guaranteed from +IN common mode rejection test, by : +R_{IN} = 1/CMS_{IBP}.

3/ Guaranteed from V_{OUT} test with R_L = 50 Ω, by : I_{OUT} = V_{OUT}/50 Ω.

4/ Shall be guaranteed, if not tested, to the specified limits in table I.

5/ A_V = +2, R_F = 360 Ω, R_L = 100 Ω unless otherwise specified. See figure 3.

6/ Measured between 10% and 90% points.

7/ For 200 ps input transition times. Overshoot decreases as input transition time increase, especially for A_V = +1.

4. VERIFICATION

4.1 Sampling and inspection. For device classes Q and V, sampling and inspection procedures shall be in accordance with MIL-PRF-38535 or as modified in the device manufacturer's Quality Management (QM) plan. The modification in the QM plan shall not affect the form, fit, or function as described herein. For device class M, sampling and inspection procedures shall be in accordance with MIL-PRF-38535, appendix A.

4.2 Screening. For device classes Q and V, screening shall be in accordance with MIL-PRF-38535, and shall be conducted on all devices prior to qualification and technology conformance inspection. For device class M, screening shall be in accordance with method 5004 of MIL-STD-883, and shall be conducted on all devices prior to quality conformance inspection.

4.2.1 Additional criteria for device class M.

a. Burn-in test, method 1015 of MIL-STD-883.

(1) Test condition A, B, C, or D. The test circuit shall be maintained by the manufacturer under document revision level control and shall be made available to the preparing or acquiring activity upon request. The test circuit shall specify the inputs, outputs, biases, and power dissipation, as applicable, in accordance with the intent specified in method 1015 of MIL-STD-883.

(2) T_A = +125°C, minimum.

b. Interim and final electrical test parameters shall be as specified in table II herein.

STANDARD MICROCIRCUIT DRAWING DEFENSE SUPPLY CENTER COLUMBUS COLUMBUS, OHIO 43218-3990	SIZE A		5962-94677
		REVISION LEVEL B	SHEET 9

Device type	01	
Case outlines	P	2
Terminal number	Terminal symbol	
1	NC	NC
2	-INPUT	NC
3	+INPUT	NC
4	V-	NC
5	V _L	-INPUT
6	OUTPUT	NC
7	V+	+INPUT
8	V _H	NC
9	---	NC
10	---	V-
11	---	V _L
12	---	NC
13	---	NC
14	---	NC
15	---	OUTPUT
16	---	NC
17	---	V+
18	---	V _H
19	---	NC
20	---	NC

NC = No connection

FIGURE 1. Terminal connections.

STANDARD MICROCIRCUIT DRAWING DEFENSE SUPPLY CENTER COLUMBUS COLUMBUS, OHIO 43218-3990	SIZE A		5962-94677
		REVISION LEVEL B	SHEET 10

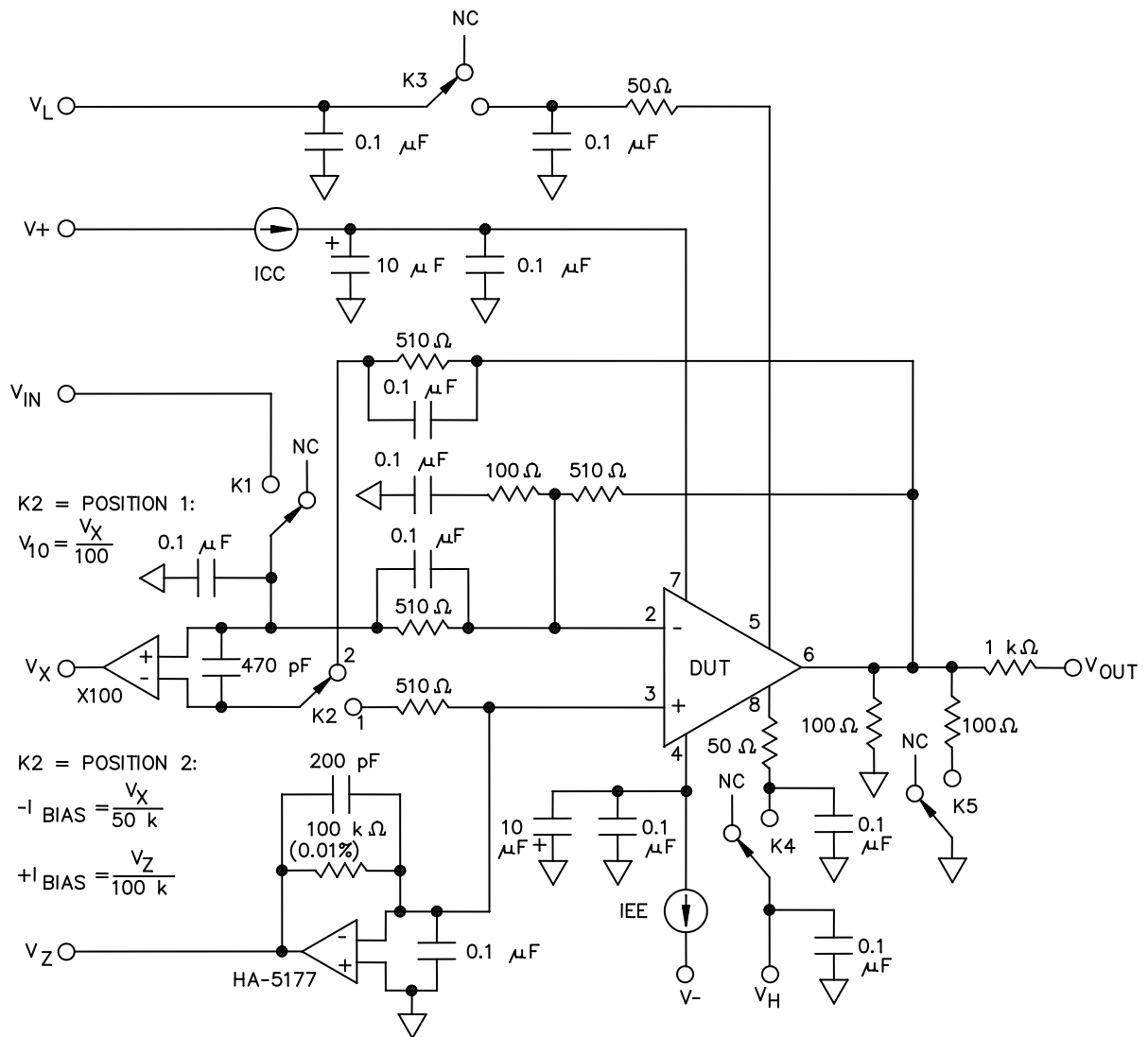

Notes:

1. All resistors = $\pm 1\%$ (Ω).
2. All capacitors = $\pm 10\%$ (μF).
3. Unless otherwise noted.
4. Chip components recommended.
5. Terminal numbers refer to DIP package.

FIGURE 2. Test circuit.

STANDARD MICROCIRCUIT DRAWING DEFENSE SUPPLY CENTER COLUMBUS COLUMBUS, OHIO 43218-3990	SIZE A		5962-94677
		REVISION LEVEL B	SHEET 11

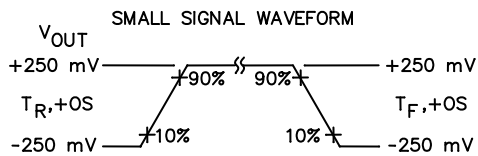
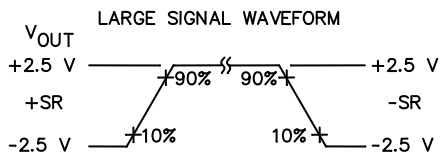
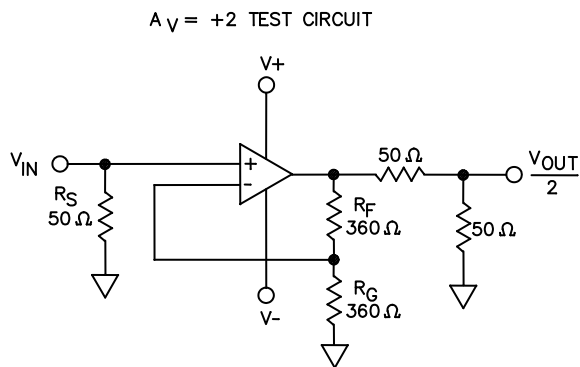
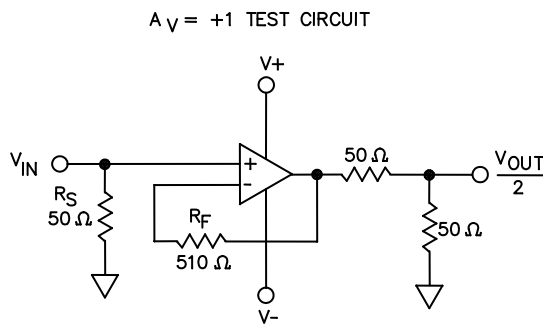

Note :

1. $V_S = \pm 5$ V, $A_V = +1$
2. $R_S = 50$ Ω
3. $R_L = 100$ Ω for small and large signals

Note :

1. $V_S = \pm 5$ V, $A_V = +2$
2. $R_S = 50$ Ω
3. $R_L = 100$ Ω for small and large signals

FIGURE 3. Test waveforms.

**STANDARD
MICROCIRCUIT DRAWING**
DEFENSE SUPPLY CENTER COLUMBUS
COLUMBUS, OHIO 43218-3990

SIZE
A

REVISION LEVEL
B

5962-94677

SHEET
12

4.2.2 Additional criteria for device classes Q and V.

- a. The burn-in test duration, test condition and test temperature, or approved alternatives shall be as specified in the device manufacturer's QM plan in accordance with MIL-PRF-38535. The burn-in test circuit shall be maintained under document revision level control of the device manufacturer's Technology Review Board (TRB) in accordance with MIL-PRF-38535 and shall be made available to the acquiring or preparing activity upon request. The test circuit shall specify the inputs, outputs, biases, and power dissipation, as applicable, in accordance with the intent specified in method 1015 of MIL-STD-883.
- b. Interim and final electrical test parameters shall be as specified in table II herein.
- c. Additional screening for device class V beyond the requirements of device class Q shall be as specified in MIL-PRF-38535, appendix B.

4.3 Qualification inspection for device classes Q and V. Qualification inspection for device classes Q and V shall be in accordance with MIL-PRF-38535. Inspections to be performed shall be those specified in MIL-PRF-38535 and herein for groups A, B, C, D, and E inspections (see 4.4.1 through 4.4.4).

4.4 Conformance inspection. Technology conformance inspection for classes Q and V shall be in accordance with MIL-PRF-38535 including groups A, B, C, D, and E inspections and as specified herein. Quality conformance inspection for device class M shall be in accordance with MIL-PRF-38535, appendix A and as specified herein. Inspections to be performed for device class M shall be those specified in method 5005 of MIL-STD-883 and herein for groups A, B, C, D, and E inspections (see 4.4.1 through 4.4.4).

4.4.1 Group A inspection.

- a. Tests shall be as specified in table II herein.
- b. Subgroups 5, 6, 7, 8, 10, and 11 in table I, method 5005 of MIL-STD-883 shall be omitted.

4.4.2 Group C inspection. The group C inspection end-point electrical parameters shall be as specified in table II herein.

4.4.2.1 Additional criteria for device class M. Steady-state life test conditions, method 1005 of MIL-STD-883:

- a. Test condition A, B, C, or D. The test circuit shall be maintained by the manufacturer under document revision level control and shall be made available to the preparing or acquiring activity upon request. The test circuit shall specify the inputs, outputs, biases, and power dissipation, as applicable, in accordance with the intent specified in method 1005 of MIL-STD-883.
- b. $T_A = +125^{\circ}\text{C}$, minimum.
- c. Test duration: 1,000 hours, except as permitted by method 1005 of MIL-STD-883.

4.4.2.2 Additional criteria for device classes Q and V. The steady-state life test duration, test condition and test temperature, or approved alternatives shall be as specified in the device manufacturer's QM plan in accordance with MIL-PRF-38535. The test circuit shall be maintained under document revision level control by the device manufacturer's TRB in accordance with MIL-PRF-38535 and shall be made available to the acquiring or preparing activity upon request. The test circuit shall specify the inputs, outputs, biases, and power dissipation, as applicable, in accordance with the intent specified in method 1005 of MIL-STD-883.

STANDARD MICROCIRCUIT DRAWING DEFENSE SUPPLY CENTER COLUMBUS COLUMBUS, OHIO 43218-3990	SIZE A		5962-94677
		REVISION LEVEL B	SHEET 13

TABLE II. Electrical test requirements.

Test requirements	Subgroups (in accordance with MIL-STD-883, method 5005, table I)	Subgroups (in accordance with MIL-PRF-38535, table III)	
	Device class M	Device class Q	Device class V
Interim electrical parameters (see 4.2)	1	1	1
Final electrical parameters (see 4.2)	1,2,3 <u>1/</u>	1,2,3 <u>1/</u>	1,2,3 <u>1/</u>
Group A test requirements (see 4.4)	1,2,3,4,9 <u>2/</u>	1,2,3,4,9	1,2,3,4,9
Group C end-point electrical parameters (see 4.4)	1	1	1,2,3,4,9
Group D end-point electrical parameters (see 4.4)	1	1	1
Group E end-point electrical parameters (see 4.4)	---	---	---

1/ PDA applies to subgroup 1.

2/ Subgroups 4 and 9 are guaranteed if not tested.

4.4.3 Group D inspection. The group D inspection end-point electrical parameters shall be as specified in table II herein.

4.4.4 Group E inspection. Group E inspection is required only for parts intended to be marked as radiation hardness assured (see 3.5 herein).

- a. End-point electrical parameters shall be as specified in table II herein.
- b. For device classes Q and V, the devices or test vehicle shall be subjected to radiation hardness assured tests as specified in MIL-PRF-38535 for the RHA level being tested. For device class M, the devices shall be subjected to radiation hardness assured tests as specified in MIL-PRF-38535, appendix A for the RHA level being tested. All device classes must meet the post irradiation end-point electrical parameter limits as defined in table I at $T_A = +25^{\circ}\text{C} \pm 5^{\circ}\text{C}$, after exposure, to the subgroups specified in table II herein.

5. PACKAGING

5.1 Packaging requirements. The requirements for packaging shall be in accordance with MIL-PRF-38535 for device classes Q and V or MIL-PRF-38535, appendix A for device class M.

6. NOTES

6.1 Intended use. Microcircuits conforming to this drawing are intended for use for Government microcircuit applications (original equipment), design applications, and logistics purposes.

6.1.1 Replaceability. Microcircuits covered by this drawing will replace the same generic device covered by a contractor prepared specification or drawing.

6.1.2 Substitutability. Device class Q devices will replace device class M devices.

6.2 Configuration control of SMD's. All proposed changes to existing SMD's will be coordinated with the users of record for the individual documents. This coordination will be accomplished using DD Form 1692, Engineering Change Proposal.

STANDARD MICROCIRCUIT DRAWING DEFENSE SUPPLY CENTER COLUMBUS COLUMBUS, OHIO 43218-3990	SIZE A		5962-94677
		REVISION LEVEL B	SHEET 14

6.3 Record of users. Military and industrial users should inform Defense Supply Center Columbus (DSCC) when a system application requires configuration control and which SMD's are applicable to that system. DSCC will maintain a record of users and this list will be used for coordination and distribution of changes to the drawings. Users of drawings covering microelectronic devices (FSC 5962) should contact DSCC-VA, telephone (614) 692-0544.

6.4 Comments. Comments on this drawing should be directed to DSCC-VA , Columbus, Ohio 43218-3990, or telephone (614) 692-0547.

6.5 Abbreviations, symbols, and definitions. The abbreviations, symbols, and definitions used herein are defined in MIL-PRF-38535 and MIL-HDBK-1331.

6.6 Sources of supply.

6.6.1 Sources of supply for device classes Q and V. Sources of supply for device classes Q and V are listed in QML-38535. The vendors listed in QML-38535 have submitted a certificate of compliance (see 3.6 herein) to DSCC-VA and have agreed to this drawing.

6.6.2 Approved sources of supply for device class M. Approved sources of supply for class M are listed in MIL-HDBK-103. The vendors listed in MIL-HDBK-103 have agreed to this drawing and a certificate of compliance (see 3.6 herein) has been submitted to and accepted by DSCC-VA.

STANDARD MICROCIRCUIT DRAWING DEFENSE SUPPLY CENTER COLUMBUS COLUMBUS, OHIO 43218-3990	SIZE A		5962-94677
		REVISION LEVEL B	SHEET 15

STANDARD MICROCIRCUIT DRAWING BULLETIN

DATE: 09-11-03

Approved sources of supply for SMD 5962-94677 are listed below for immediate acquisition information only and shall be added to MIL-HDBK-103 and QML-38535 during the next revision. MIL-HDBK-103 and QML-38535 will be revised to include the addition or deletion of sources. The vendors listed below have agreed to this drawing and a certificate of compliance has been submitted to and accepted by DSCC-VA. This information bulletin is superseded by the next dated revision of MIL-HDBK-103 and QML-38535. DSCC maintains an online database of all current sources of supply at <http://www.dsccl.dla.mil/Programs/Smcr/> .

Standard microcircuit drawing PIN <u>1/</u>	Vendor CAGE number	Vendor similar PIN <u>2/</u>
5962-9467701MPA	<u>3/</u>	HFA1130MJ/883
5962-9467701M2A	34371	HFA1130M

1/ The lead finish shown for each PIN representing a hermetic package is the most readily available from the manufacturer listed for that part. If the desired lead finish is not listed contact the vendor to determine its availability.

2/ Caution. Do not use this number for item acquisition. Items acquired to this number may not satisfy the performance requirements of this drawing.

3/ Not available from an approved source of supply.

Vendor CAGE number

24355

Vendor name and address

Intersil Corporation
 1001 Murphy Ranch Road
 Milpitas, CA 95035-6803
 Point of contact: 1650 Robert J. Conlan Blvd
 Palm Bay, FL 32905

The information contained herein is disseminated for convenience only and the Government assumes no liability whatsoever for any inaccuracies in the information bulletin.