

REVISIONS

LTR	DESCRIPTION	DATE (YR-MO-DA)	APPROVED
A	Changes in accordance with NOR 5962-R057-93.	92-12-29	Michael A. Frye
B	Drawing updated to reflect current requirements. - ro	02-03-07	Raymond Monnin
C	Redrawn. Update paragraphs to MIL-PRF-38535 requirements. - drw	14-01-17	Charles F. Saffle
D	Update drawing to current MIL-PRF-38535 requirements. - drw	19-04-08	Charles F. Saffle

THE ORIGINAL FIRST SHEET OF THIS DRAWING HAS BEEN REPLACED.



REV																				
SHEET																				
REV																				
SHEET																				
REV STATUS OF SHEETS	REV SHEET	D	D	D	D	D	D	D	D	D	D	D	D							
PMIC N/A	PREPARED BY Dan Wonnell	<p align="center">DLA LAND AND MARITIME COLUMBUS, OHIO 43218-3990 https://www.dla.mil/landandmaritime</p>																		
<p align="center">STANDARD MICROCIRCUIT DRAWING</p> <p>THIS DRAWING IS AVAILABLE FOR USE BY ALL DEPARTMENTS AND AGENCIES OF THE DEPARTMENT OF DEFENSE</p> <p align="center">AMSC N/A</p>	CHECKED BY Sandra Rooney																			
	APPROVED BY Michael A. Frye	<p align="center">MICROCIRCUIT, LINEAR, DIGITAL TO ANALOG CONVERTER, 12 BIT, HIGH SPEED, MONOLITHIC SILICON</p>																		
	DRAWING APPROVAL DATE 92-07-15																			
	REVISION LEVEL D	<table border="1"> <tr> <td>SIZE A</td> <td>CAGE CODE 67268</td> <td>5962-89808</td> </tr> </table>	SIZE A	CAGE CODE 67268	5962-89808															
SIZE A	CAGE CODE 67268	5962-89808																		
		SHEET	1 OF 11																	

1. SCOPE

1.1 Scope. This drawing describes device requirements for MIL-STD-883 compliant, non-JAN class level B microcircuits in accordance with MIL-PRF-38535, appendix A.

1.2 Part or Identifying Number (PIN). The complete PIN is as shown in the following example:

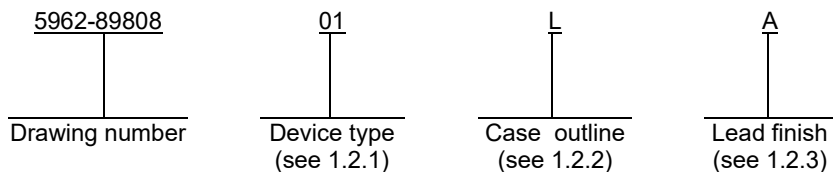

1.2.1 Device types. The device types identify the circuit function as follows:

<u>Device type</u>	<u>Generic number</u>	<u>Circuit function</u>
01	AD568SQ	12-bit high speed D/A converter
02	AD568SE	12-bit high speed D/A converter

1.2.2 Case outlines. The case outlines are as designated in MIL-STD-1835 as follows:

<u>Outline letter</u>	<u>Descriptive designator</u>	<u>Terminals</u>	<u>Package style</u>
J	GDIP1-T24 or CDIP2-T24	24	Dual-in-line
L	GDIP3-T24 or CDIP4-T24	24	Dual-in-line
3	CQCC1-N28	28	Square leadless chip carrier

1.2.3 Lead finish. The lead finish is as specified in MIL-PRF-38535, appendix A.

1.3 Absolute maximum ratings.

VCC to reference common range	0 V dc to +18 V dc
VEE to reference common range	0 V dc to -18 V dc
Reference common to ladder common range	+100 mV to -10 V dc
Analog common to ladder common	±100 mV
Threshold common to ladder common	±500 mV
10 V span resistor to ladder common	±12 V
Bipolar offset to ladder common	±5 V
IOUT to ladder common	-5 V dc to threshold control
Digital inputs to threshold common range	-500 mV to +7.0 V dc
Voltage across span resistor	12 V dc
Threshold control to threshold common range	-0.7 V dc to +1.4 V dc
Logic threshold control input current	5 mA
Power dissipation (Pd):	
Cases J and L	1000 mW
Case 3	600 mW
Storage temperature range	-65°C to +150°C
Junction temperature (Tj)	200°C

STANDARD MICROCIRCUIT DRAWING DLA LAND AND MARITIME COLUMBUS, OHIO 43218-3990	SIZE A		5962-89808
		REVISION LEVEL D	SHEET 2

1.3 Absolute maximum ratings - continued.

Thermal resistance junction-to-case (θ_{JC}):

Cases J and L 25°C/W
 Case 3 42°C/W

Thermal resistance junction-to-ambient (θ_{JA}):

Cases J and L 75°C/W
 Case 3 125°C/W

1.4 Recommended operating conditions.

VCC to reference common range +13.5 V dc to +16.5 V dc
 VEE to reference common range -13.5 V dc to -16.5 V dc
 Ambient operating temperature range (TA) -55°C to +125°C

2. APPLICABLE DOCUMENTS

2.1 Government specification, standards, and handbooks. The following specification, standards, and handbooks form a part of this drawing to the extent specified herein. Unless otherwise specified, the issues of these documents are those cited in the solicitation or contract.

DEPARTMENT OF DEFENSE SPECIFICATION

MIL-PRF-38535 - Integrated Circuits, Manufacturing, General Specification for.

DEPARTMENT OF DEFENSE STANDARDS

MIL-STD-883 - Test Method Standard Microcircuits.
 MIL-STD-1835 - Interface Standard Electronic Component Case Outlines.

DEPARTMENT OF DEFENSE HANDBOOKS

MIL-HDBK-103 - List of Standard Microcircuit Drawings.
 MIL-HDBK-780 - Standard Microcircuit Drawings.

(Copies of these documents are available online at <https://quicksearch.dla.mil>).

2.2 Order of precedence. In the event of a conflict between the text of this drawing and the references cited herein, the text of this drawing takes precedence. Nothing in this document, however, supersedes applicable laws and regulations unless a specific exemption has been obtained.

STANDARD MICROCIRCUIT DRAWING DLA LAND AND MARITIME COLUMBUS, OHIO 43218-3990	SIZE A		5962-89808
		REVISION LEVEL D	SHEET 3

3. REQUIREMENTS

3.1 Item requirements. The individual item requirements shall be in accordance with MIL-PRF-38535, appendix A for non-JAN class level B devices and as specified herein. Product built to this drawing that is produced by a Qualified Manufacturer Listing (QML) certified and qualified manufacturer or a manufacturer who has been granted transitional certification to MIL-PRF-38535 may be processed as QML product in accordance with the manufacturers approved program plan and qualifying activity approval in accordance with MIL-PRF-38535. This QML flow as documented in the Quality Management (QM) plan may make modifications to the requirements herein. These modifications shall not affect form, fit, or function of the device. These modifications shall not affect the PIN as described herein. A "Q" or "QML" certification mark in accordance with MIL-PRF-38535 is required to identify when the QML flow option is used.

3.2 Design, construction, and physical dimensions. The design, construction, and physical dimensions shall be as specified in MIL-PRF-38535, appendix A and herein.

3.2.1 Case outlines. The case outlines shall be in accordance with 1.2.2 herein.

3.2.2 Terminal connections. The terminal connections shall be as specified on figure 1.

3.2.3 Functional block diagram. The functional block diagram shall be as specified on figure 2.

3.3 Electrical performance characteristics. Unless otherwise specified herein, the electrical performance characteristics are as specified in table I and shall apply over the full ambient operating temperature range.

3.4 Electrical test requirements. The electrical test requirements shall be the subgroups specified in table II. The electrical tests for each subgroup are described in table I.

3.5 Marking. Marking shall be in accordance with MIL-PRF-38535, appendix A. The part shall be marked with the PIN listed in 1.2 herein. In addition, the manufacturer's PIN may also be marked. For packages where marking of the entire SMD PIN number is not feasible due to space limitations, the manufacturer has the option of not marking the "5962-" on the device.

3.5.1 Certification/compliance mark. A compliance indicator "C" shall be marked on all non-JAN devices built in compliance to MIL-PRF-38535, appendix A. The compliance indicator "C" shall be replaced with a "Q" or "QML" certification mark in accordance with MIL-PRF-38535 to identify when the QML flow option is used.

3.6 Certificate of compliance. A certificate of compliance shall be required from a manufacturer in order to be listed as an approved source of supply in MIL-HDBK-103 (see 6.6 herein). The certificate of compliance submitted to DLA Land and Maritime -VA prior to listing as an approved source of supply shall affirm that the manufacturer's product meets the requirements of MIL-PRF-38535, appendix A and the requirements herein.

3.7 Certificate of conformance. A certificate of conformance as required in MIL-PRF-38535, appendix A shall be provided with each lot of microcircuits delivered to this drawing.

3.8 Notification of change. Notification of change to DLA Land and Maritime -VA shall be required for any change that affects this drawing.

3.9 Verification and review. DLA Land and Maritime, DLA Land and Maritime's agent, and the acquiring activity retain the option to review the manufacturer's facility and applicable required documentation. Offshore documentation shall be made available onshore at the option of the reviewer.

STANDARD MICROCIRCUIT DRAWING DLA LAND AND MARITIME COLUMBUS, OHIO 43218-3990	SIZE A		5962-89808
		REVISION LEVEL D	SHEET 4

TABLE I. Electrical performance characteristics.

Test	Symbol	Conditions -55°C ≤ TA ≤ +125°C VCC = +15 V, VEE = -15 V unless otherwise specified	Group A subgroups	Device type	Limits <u>1/</u>		Unit
					Min	Max	
Relative accuracy	RA	IOUT mode	1	All	-0.5	+0.5	LSB
			2, 3	01	-0.75	+0.75	
				02	-1	+1	
Differential nonlinearity	DNL	IOUT mode	1, 2, 3	All	-1	+1	LSB
Gain error	AE	All bits on, IOUT mode	1	All	-1	+1	% of FSR
Gain drift temperature coefficient	TCAE	All bits on, VOUT mode	2, 3	01	-50	+50	ppm of FSR/°C
				02	-60	+60	
		All bits on, IOUT mode		All	-150	+150	
Unipolar offset	UOS	All bits off, IOUT mode	1	All	-0.2	+0.2	% of FSR
Unipolar offset temperature coefficient	TCUOS	All bits off, VOUT mode	2, 3	All	-5	+5	ppm of FSR/°C
Bipolar offset	BPOS	IOUT mode, all bits off bipolar	1	All	-1.0	+1.0	% of FSR
Bipolar offset temperature coefficient	TCBPOS	VOUT mode, all bits off bipolar	2, 3	01	-30	+30	ppm of FSR/°C
				02	-40	+40	
Bipolar zero	BPZE	IOUT mode, MSB on, all other bits off bipolar	1	All	-0.2	+0.2	% of FSR
Bipolar zero temperature coefficient	TCBPZE	VOUT mode, MSB on, all other bits off bipolar	2, 3	All	-15	+15	ppm of FSR/°C
High input voltage	VIH		1, 2, 3	All	2.0	7.0	V
Low input voltage	VIL		1, 2, 3	All	0.0	0.8	V

See footnotes at end of table.

**STANDARD
MICROCIRCUIT DRAWING**
DLA LAND AND MARITIME
COLUMBUS, OHIO 43218-3990

SIZE
A

5962-89808

REVISION LEVEL
D

SHEET
5

TABLE I. Electrical performance characteristics – continued.

Test	Symbol	Conditions -55°C ≤ TA ≤ +125°C VCC = +15 V, VEE = -15 V unless otherwise specified	Group A subgroups	Device type	Limits <u>1/</u>		Unit
					Min	Max	
High input current	I _{IH}	V _{IH} = 7 V	1, 2, 3	All	-10.0	+10.0	μA
Low input current	I _{IL}	V _{IL} = 0.0 V	1	All	-100	-0.5	μA
			2, 3		-200	-0.5	
Output current	I _O	Unipolar, all bits on	1	All	10.137	10.343	mA
			2, 3		9.985	10.50	
		Bipolar, all bits on	1		5.017	5.223	
			2, 3		4.942	5.300	
Output voltage	V _O	Unipolar, all bits on	1	All	1.014	1.034	V
			2, 3		1.008	1.040	
		Bipolar, all bits on	1		0.507	0.517	
			2, 3		0.504	0.520	
Compliance voltage	V _C	<u>2/</u>	1, 2, 3	All	-2	+1.2	V
Output resistance exclusive of R _L	R _{OE}	<u>2/</u>	1, 2, 3	All	160	240	Ω
Output resistance inclusive of R _L	R _{OI}	<u>2/</u>	1, 2, 3	All	99	101	Ω
Settling time	t _{SL}	Current to ±0.025 % of FSR <u>2/</u>	9	All		120	ns
			10, 11			165	
		Current to ±0.1 % of FSR <u>2/</u>	9			125	
			10, 11			130	

See footnotes at end of table.

**STANDARD
MICROCIRCUIT DRAWING**
DLA LAND AND MARITIME
COLUMBUS, OHIO 43218-3990

SIZE
A

REVISION LEVEL
D

5962-89808

SHEET
6

TABLE I. Electrical performance characteristics – continued.

Test	Symbol	Conditions -55°C ≤ TA ≤ +125°C VCC = +15 V, VEE = -15 V unless otherwise specified	Group A subgroups	Device type	Limits <u>1/</u>		Unit
					Min	Max	
Rise time	tR	From 10 % to 90 %, <u>2/</u> VOUT mode	9, 10, 11	All		20	ns
Fall time	tF	From 90 % to 10 %, <u>2/</u> VOUT mode	9, 10, 11	All		20	ns
Power supply current	ICC	VCC = 16.5 V, VEE = -16.5 V, VOUT = 5 V	1, 2, 3	All		32	mA
	IEE	VCC = 16.5 V, VEE = -16.5 V, VOUT = 5 V			-8		
Power supply rejection ratio	+PSRR	13.5 V ≤ VCC ≤ 16.5 V, VEE = -15 V	1	All		0.05	% of FSR/V
			2, 3			0.06	
	-PSRR	-13.5 V ≤ VEE ≤ -16.5 V, VCC = 15 V	1			0.05	
			2, 3			0.06	

1/ The algebraic convention whereby the most negative value is minimum and the most positive a maximum, is used in this table. Negative current shall be defined as conventional current flow out of a device terminal.

2/ If not tested, shall be guaranteed to the limits specified in table I herein.

**STANDARD
MICROCIRCUIT DRAWING**
DLA LAND AND MARITIME
COLUMBUS, OHIO 43218-3990

SIZE
A

5962-89808

REVISION LEVEL
D

SHEET
7

Device types	01	02
Case outlines	J and L	3
Terminal number	Terminal symbol	
1	BIT 1 (MSB)	NC
2	BIT 2	BIT 1 (MSB)
3	BIT 3	BIT 2
4	BIT 4	BIT 3
5	BIT 5	BIT 4
6	BIT 6	BIT 5
7	BIT 7	BIT 6
8	BIT 8	NC
9	BIT 9	BIT 7
10	BIT 10	BIT 8
11	BIT 11	BIT 9
12	BIT 12 (LSB)	BIT 10
13	THRESHOLD CONTROL (V _{TH})	BIT 11
14	THRESHOLD COMMON (THCOM)	BIT 12 (LSB)
15	10 V SPAN RESISTOR	NC
16	10 V SPAN RESISTOR	THRESHOLD CONTROL (V _{TH})
17	LADDER COMMON (LCOM)	THRESHOLD COMMON (THCOM)
18	ANALOG COMMON (ACOM)	10 V SPAN RESISTOR
19	LOAD RESISTOR (RL)	10 V SPAN RESISTOR
20	IOUT	LADDER COMMON (LCOM)
21	BIPOLAR OFFSET (IBPO)	ANALOG COMMON (ACOM)
22	VEE	NC
23	REFERENCE COMMON (REFCOM)	LOAD RESISTOR (RL)
24	VCC	IOUT
25	---	BIPOLAR OFFSET (IBPO)
26	---	VEE
27	---	REFERENCE COMMON (REFCOM)
28	---	VCC

NC = No connection

FIGURE 1. Terminal connections.

STANDARD MICROCIRCUIT DRAWING DLA LAND AND MARITIME COLUMBUS, OHIO 43218-3990	SIZE A		5962-89808
		REVISION LEVEL D	SHEET 8

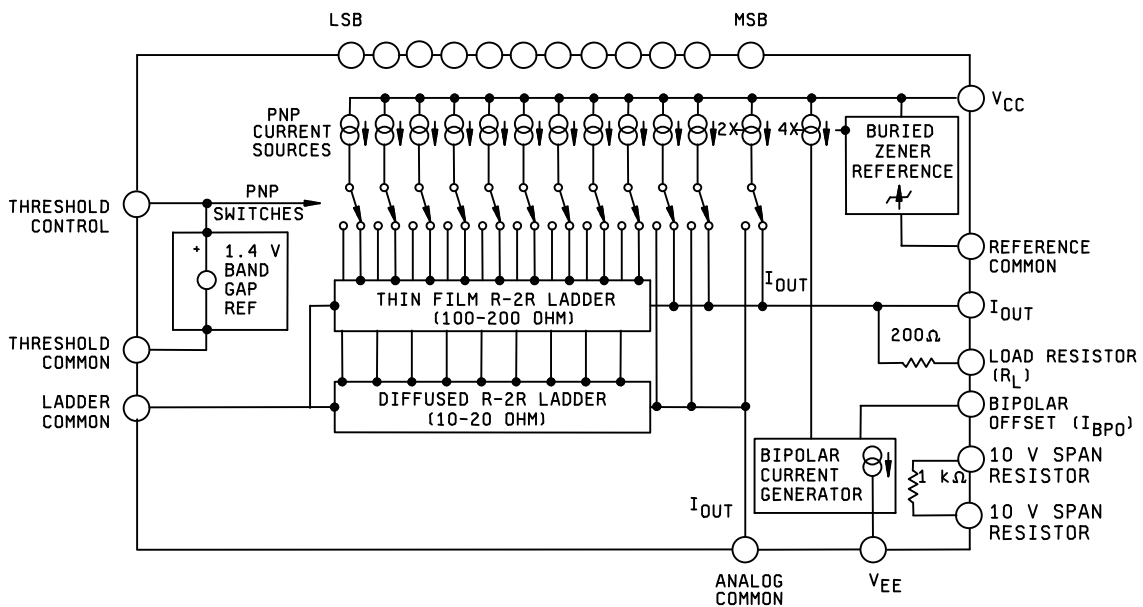

FIGURE 2. Functional block diagram.

**STANDARD
MICROCIRCUIT DRAWING**

DLA LAND AND MARITIME
COLUMBUS, OHIO 43218-3990

SIZE
A

5962-89808

REVISION LEVEL
D

SHEET
9

4. VERIFICATION

4.1 Sampling and inspection. Sampling and inspection procedures shall be in accordance with MIL-PRF-38535, appendix A.

4.2 Screening. Screening shall be in accordance with method 5004 of MIL-STD-883, and shall be conducted on all devices prior to quality conformance inspection. The following additional criteria shall apply:

a. Burn-in test, method 1015 of MIL-STD-883.

(1) Test condition A, B, C, or D. The test circuit shall be maintained by the manufacturer under document revision level control and shall be made available to the preparing or acquiring activity upon request. The test circuit shall specify the inputs, outputs, biases, and power dissipation, as applicable, in accordance with the intent specified in method 1015 of MIL-STD-883.

(2) T_A = +125°C, minimum.

b. Interim and final electrical test parameters shall be as specified in table II herein, except interim electrical parameter tests prior to burn-in are optional at the discretion of the manufacturer.

TABLE II. Electrical test requirements.

MIL-STD-883 test requirements	Subgroups (in accordance with MIL-STD-883, method 5005, table I)
Interim electrical parameters (method 5004)	1
Final electrical test parameters (method 5004)	1*, 2, 3
Group A test requirements (method 5005)	1, 2, 3, 9**, 10**, 11**
Groups C and D end-point electrical parameters (method 5005)	1

* PDA applies to subgroup 1.

** Subgroups 9, 10, and 11, if not tested, shall be guaranteed.

4.3 Quality conformance inspection. Quality conformance inspection shall be in accordance with method 5005 of MIL-STD-883 including groups A, B, C, and D inspections. The following additional criteria shall apply.

4.3.1 Group A inspection.

a. Tests shall be as specified in table II herein.

b. Subgroups 4, 5, 6, 7 and 8 in table I, method 5005 of MIL-STD-883 shall be omitted.

STANDARD MICROCIRCUIT DRAWING DLA LAND AND MARITIME COLUMBUS, OHIO 43218-3990	SIZE A		5962-89808
		REVISION LEVEL D	SHEET 10

4.3.2 Groups C and D inspections.

- a. End-point electrical parameters shall be as specified in table II herein.
- b. Steady-state life test conditions, method 1005 of MIL-STD-883.
 - (1) Test condition A, B, C, or D. The test circuit shall be maintained by the manufacturer under document revision level control and shall be made available to the preparing or acquiring activity upon request. The test circuit shall specify the inputs, outputs, biases, and power dissipation, as applicable, in accordance with the intent specified in method 1005 of MIL-STD-883.
 - (2) $T_A = +125^{\circ}\text{C}$, minimum.
 - (3) Test duration: 1,000 hours, except as permitted by method 1005 of MIL-STD-883.

5. PACKAGING

5.1 Packaging requirements. The requirements for packaging shall be in accordance with MIL-PRF-38535, appendix A.

6. NOTES

6.1 Intended use. Microcircuits conforming to this drawing are intended for use for Government microcircuit applications (original equipment), design applications, and logistics purposes.

6.2 Replaceability. Microcircuits covered by this drawing will replace the same generic device covered by a contractor-prepared specification or drawing.

6.3 Configuration control of SMD's. All proposed changes to existing SMD's will be coordinated with the users of record for the individual documents. This coordination will be accomplished using DD Form 1692, Engineering Change Proposal.

6.4 Record of users. Military and industrial users shall inform DLA Land and Maritime when a system application requires configuration control and the applicable SMD to that system. DLA Land and Maritime will maintain a record of users and this list will be used for coordination and distribution of changes to the drawings. Users of drawings covering microelectronics devices (FSC 5962) should contact DLA Land and Maritime-VA, telephone (614) 692-8108.

6.5 Comments. Comments on this drawing should be directed to DLA Land and Maritime-VA, Columbus, Ohio 43218-3990, or telephone (614) 692-0540.

6.6 Approved sources of supply. Approved sources of supply are listed in MIL-HDBK-103 and QML-38535. The vendors listed in MIL-HDBK-103 and QML-38535 have agreed to this drawing and a certificate of compliance (see 3.6 herein) has been submitted to and accepted by DLA Land and Maritime-VA.

STANDARD MICROCIRCUIT DRAWING DLA LAND AND MARITIME COLUMBUS, OHIO 43218-3990	SIZE A		5962-89808
		REVISION LEVEL D	SHEET 11

STANDARD MICROCIRCUIT DRAWING BULLETIN

DATE: 19-04-08

Approved sources of supply for SMD 5962-89808 are listed below for immediate acquisition information only and shall be added to MIL-HDBK-103 and QML-38535 during the next revision. MIL-HDBK-103 and QML-38535 will be revised to include the addition or deletion of sources. The vendors listed below have agreed to this drawing and a certificate of compliance has been submitted to and accepted by DLA Land and Maritime-VA. This information bulletin is superseded by the next dated revision of MIL-HDBK-103 and QML-38535. DLA Land and Maritime maintains an online database of all current sources of supply at: <https://landandmaritimeapps.dla.mil/programs/smcr/>

Standard microcircuit drawing PIN <u>1/</u>	Vendor CAGE number	Vendor similar PIN <u>2/</u>
5962-8980801JA	<u>3/</u>	AD568SQ/883B
5962-8980801LA	24355	AD568SQ/883B
5962-89808023A	<u>3/</u>	AD568SE/883B

- 1/ The lead finish shown for each PIN representing a hermetic package is the most readily available from the manufacturer listed for that part. If the desired lead finish is not listed contact the vendor to determine its availability.
- 2/ Caution. Do not use this number for item acquisition. Items acquired to this number may not satisfy the performance requirements of this drawing.
- 3/ Not available from an approved source of supply.

Vendor CAGE
number

24355

Vendor name
and address

Analog Devices
Route 1 Industrial Park
P.O. Box 9106
Norwood, MA 02062
Point of contact: 804 Woburn Street
Wilmington, MA 01887-3462

The information contained herein is disseminated for convenience only and the Government assumes no liability whatsoever for any inaccuracies in the information bulletin.