

REVISIONS			
LTR	DESCRIPTION	DATE (YR-MO-DA)	APPROVED
A	Make correction to pin assignments as specified in figure 2. - ro	02-02-13	R. MONNIN
B	Make correction to the descriptive designator as specified in 1.2.4. - ro	02-12-04	R. MONNIN
C	Add a new footnote under paragraph 1.5 and Table I. Delete paragraphs 4.4.4.2, 4.4.4.3, and 4.4.4.4. - ro	05-06-21	R. MONNIN
D	Make correction to terminal number column as specified under figure 1. - ro	07-01-16	J. RODENBECK
E	Add device type 02. Add ASTM F1192 information under section 2, Table IB, and paragraph A.1.5. Delete radiation exposure circuit. - ro	12-08-13	C. SAFFLE
F	Delete references to device class M requirements. Update document paragraphs to current MIL-PRF-38535 requirements. - ro	17-10-17	C. SAFFLE
G	Under TABLE IA, Input voltage common mode rejection ratio (CMRR) test, move the limits from the max column to the min column. Add device type 02 to paragraph A.1.2.4. - ro	18-04-04	C. SAFFLE
H	Drawing updated to reflect current MIL-PRF-38535 requirements. -rrp	24-02-26	J. ESCHMEYER



REV																				
SHEET																				
REV	H	H	H	H	H															
SHEET	15	16	17	18	19															
REV STATUS OF SHEETS	REV			H	H	H	H	H	H	H	H	H	H	H	H	H	H	H	H	H
	SHEET			1	2	3	4	5	6	7	8	9	10	11	12	13	14			

PMIC N/A	PREPARED BY RICK OFFICER	<b>DLA LAND AND MARITIME</b> <b>COLUMBUS, OHIO 43218-3990</b> <a href="https://www.dla.mil/LandandMaritime">https://www.dla.mil/LandandMaritime</a>																	
<b>STANDARD MICROCIRCUIT DRAWING</b>  THIS DRAWING IS AVAILABLE FOR USE BY ALL DEPARTMENTS AND AGENCIES OF THE DEPARTMENT OF DEFENSE  AMSC N/A	CHECKED BY RAJESH PITHADIA																		
	APPROVED BY RAYMOND MONNIN	MICROCIRCUIT, LINEAR, RADIATION HARDENED, QUAD VOLTAGE COMPARATOR, MONOLITHIC SILICON																	
	DRAWING APPROVAL DATE 00-12-21																		
	REVISION LEVEL H	<table border="1"> <tr> <td>SIZE A</td> <td>CAGE CODE <b>67268</b></td> <td><b>5962-01510</b></td> </tr> </table>	SIZE A	CAGE CODE <b>67268</b>	<b>5962-01510</b>														
SIZE A	CAGE CODE <b>67268</b>	<b>5962-01510</b>																	
		SHEET 1 OF 19																	

1. SCOPE

1.1 Scope. This drawing documents two product assurance class levels consisting of high reliability (device class Q) and space application (device class V). A choice of case outlines and lead finishes are available and are reflected in the Part or Identifying Number (PIN). When available, a choice of Radiation Hardness Assurance (RHA) levels is reflected in the PIN.

1.2 PIN. The PIN is as shown in the following example:

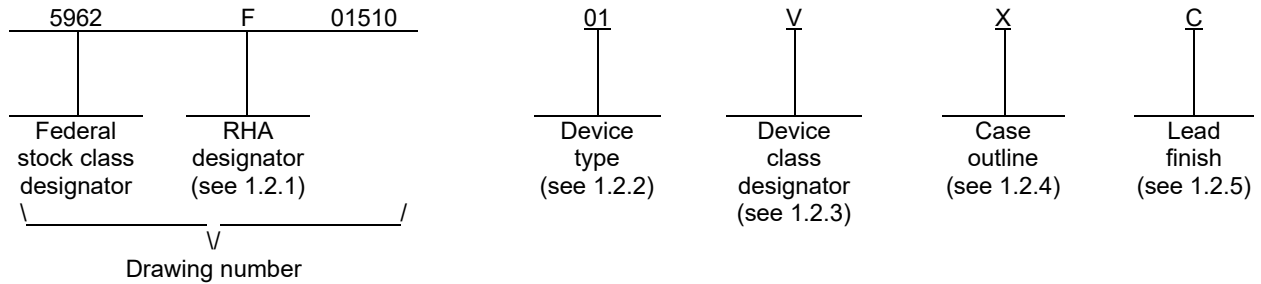

1.2.1 RHA designator. Device classes Q and V RHA marked devices meet the MIL-PRF-38535 specified RHA levels and are marked with the appropriate RHA designator. A dash (-) indicates a non-RHA device.

1.2.2 Device type(s). The device type(s) identify the circuit function as follows:

<u>Device type</u>	<u>Generic number</u>	<u>Circuit function</u>
01	IS-139ASRH	Single event radiation hardened quad voltage comparator
02	IS-139ASEH	Single event radiation hardened quad voltage comparator

1.2.3 Device class designator. The device class designator is a single letter identifying the product assurance level as follows:

<u>Device class</u>	<u>Device requirements documentation</u>
Q or V	Certification and qualification to MIL-PRF-38535

1.2.4 Case outline(s). The case outline(s) are as designated in MIL-STD-1835 and as follows:

<u>Outline letter</u>	<u>Descriptive designator</u>	<u>Terminals</u>	<u>Package style</u>
X	CDFP4-F20	20	Flat pack

1.2.5 Lead finish. The lead finish is as specified in MIL-PRF-38535 for device classes Q and V.

<b>STANDARD MICROCIRCUIT DRAWING</b> DLA LAND AND MARITIME COLUMBUS, OHIO 43218-3990	SIZE <b>A</b>		<b>5962-01510</b>
		REVISION LEVEL H	SHEET 2

1.3 Absolute maximum ratings. 1/

Supply voltage range (+VCC) .....	33 V dc
Input voltage range (VIN) .....	-0.3 V dc to 33 V dc
Input current (IIN) (VIN < -0.3 V) .....	50 mA <u>2/</u>
Maximum storage temperature range .....	-65°C to 150°C
Maximum power dissipation (PD) .....	0.62 W
Lead temperature (soldering, 10 seconds) .....	+265°C maximum
Junction temperature (TJ) .....	+175°C maximum
Thermal resistance, junction-to-case (θJC) .....	15°C/W
Thermal resistance, junction-to-ambient (θJA) .....	80°C/W <u>3/</u>

1.4 Recommended operating conditions.

Supply voltage range (+VCC) .....	9 V dc to 30 V dc
Ambient operating temperature range (TA) .....	-55°C to +125°C

1.5 Radiation features.

Maximum total dose available (dose rate = 50 – 300 rads(Si)/s):	
Device type 01 .....	300 krads(Si) <u>4/</u>
Device type 02 .....	300 krads(Si) <u>5/</u>
Maximum total dose available (dose rate ≤ 0.01 rads(Si)/s):	
Device type 02 .....	50 krads(Si) <u>5/</u>
Single event phenomena (SEP) for device types 01 and 02:	
No single event burn out (SEB) occurs at effective (LET) (see 4.4.2) .....	≤ 83 MeV/mg/cm <sup>2</sup> <u>6/</u>
Single event latchup (SEL) .....	No latch up <u>7/</u>

- 1/ Stresses above the absolute maximum rating may cause permanent damage to the device. Extended operation at the maximum levels may degrade performance and affect reliability.
- 2/ Inputs must not go more negative than -0.3 V.
- 3/ θJA is measured with the component mounted on an evaluation printed circuit (PC) board in free air.
- 4/ Device type 01 may be dose rate sensitive in a space environment and may demonstrate enhanced low dose rate effects. The radiation end point limits for the noted parameters are guaranteed only for the conditions as specified in MIL-STD-883, method 1019, condition A to a maximum total dose of 300 krads(Si).
- 5/ The device type 02 radiation end point limits for the noted parameters are guaranteed only for the conditions as specified in MIL-STD-883, method 1019, condition A to a maximum total dose of 300 krads(Si), and condition D to a maximum total dose of 50 krads(Si).
- 6/ Limits are characterized at initial qualification and after any design or process changes which may affect the SEP characteristics but, are not production tested. See manufacturer's SEE test report for more information.
- 7/ Device types 01 and 02 use dielectrically isolated (DI) technology and latch-up is physically not possible.

<b>STANDARD MICROCIRCUIT DRAWING</b> DLA LAND AND MARITIME COLUMBUS, OHIO 43218-3990	SIZE <b>A</b>		<b>5962-01510</b>
		REVISION LEVEL <b>H</b>	SHEET <b>3</b>

2. APPLICABLE DOCUMENTS

2.1 Government specification, standards, and handbooks. The following specification, standards, and handbooks form a part of this drawing to the extent specified herein. Unless otherwise specified, the issues of these documents are those cited in the solicitation or contract.

DEPARTMENT OF DEFENSE SPECIFICATION

MIL-PRF-38535 - Integrated Circuits, Manufacturing, General Specification for.

DEPARTMENT OF DEFENSE STANDARDS

MIL-STD-883 - Test Method Standard Microcircuits.  
 MIL-STD-1835 - Interface Standard Electronic Component Case Outlines.

DEPARTMENT OF DEFENSE HANDBOOKS

MIL-HDBK-103 - List of Standard Microcircuit Drawings.  
 MIL-HDBK-780 - Standard Microcircuit Drawings.

(Copies of these documents are available online at <https://quicksearch.dla.mil>).

2.2 Non-Government publications. The following document(s) form a part of this document to the extent specified herein. Unless otherwise specified, the issues of these documents are those cited in the solicitation or contract.

ASTM INTERNATIONAL (ASTM)

ASTM F1192 - Standard Guide for the Measurement of Single Event Phenomena (SEP) Induced by Heavy Ion Irradiation of semiconductor Devices.

(Copies of these documents are available online at <https://www.astm.org>).

2.3 Order of precedence. In the event of a conflict between the text of this drawing and the references cited herein, the text of this drawing takes precedence. Nothing in this document, however, supersedes applicable laws and regulations unless a specific exemption has been obtained.

3. REQUIREMENTS

3.1 Item requirements. The individual item requirements for device classes Q and V shall be in accordance with MIL-PRF-38535 as specified herein, or as modified in the device manufacturer's Quality Management (QM) plan. The modification in the QM plan shall not affect the form, fit, or function as described herein.

3.1.1 Microcircuit die. For the requirements of microcircuit die, see appendix A to this document.

3.2 Design, construction, and physical dimensions. The design, construction, and physical dimensions shall be as specified in MIL-PRF-38535 and herein for device classes Q and V.

3.2.1 Case outline. The case outline shall be in accordance with 1.2.4 herein.

3.2.2 Terminal connections. The terminal connections shall be as specified on figure 1.

3.2.3 Block diagram. The block diagram shall be as specified on figure 2.

3.2.4 Timing diagrams. The timing diagrams shall be as specified on figure 3.

3.2.5 Radiation exposure circuit. The radiation exposure circuit shall be maintained by the manufacturer under document revision level control and shall be made available to the preparing and acquiring activity upon request.

3.3 Electrical performance characteristics and postirradiation parameter limits. Unless otherwise specified herein, the electrical performance characteristics and postirradiation parameter limits are as specified in table I and shall apply over the full ambient operating temperature range.

<b>STANDARD                  MICROCIRCUIT DRAWING</b> DLA LAND AND MARITIME COLUMBUS, OHIO 43218-3990	SIZE <b>A</b>		<b>5962-01510</b>
		REVISION LEVEL H	SHEET 4

TABLE IA. Electrical performance characteristics.

Test	Symbol	Conditions <u>1/ 2/</u> -55°C ≤ TA ≤ +125°C +VCC = 9 V unless otherwise specified	Group A subgroups	Device type	Limits		Unit
					Min	Max	
Input offset voltage	VIO	VREF = 1.4 V, RS = 0 Ω, output switch point = 1.4 V, +VCC = 9 V dc to 30 V	1,2	01,02	-5	+5	mV
			3		-9	+9	
			M,D,P,L,R,F		1	-9	
Saturation voltage	VSAT	-VIN = 1 V, +VIN = 0 V, ISINK ≤ 4 mA	1,2,3	01,02		300	mV
			M,D,P,L,R,F		1		
Common mode input voltage range <u>3/</u>	VICR	+VCC = 9 V dc to 30 V	1,2,3	01,02	0	+VCC -2.5	V
			M,D,P,L,R,F		1	0	
Input offset current	IIO	+IIN - -IIN, +VCC = 9 V dc to 30 V	1,2	01,02	-150	+150	nA
			3		-500	+500	
			M,D,P,L,R,F		1	-500	
Input bias current	IIB	+IIN or -IIN with output in linear range	1,2	01,02	-400	+400	nA
			3		-1000	+1000	
			M,D,P,L,R,F		1	-1000	
Total supply current	+ICC	RL = infinite on all comparators, +VCC = 9 V dc to 30 V	1,2,3	01,02		3.0	mA
			M,D,P,L,R,F		1		
Input voltage common mode rejection ratio	CMRR	+VCC = 30 V, RL ≥ 15 kΩ, VCM = 0 V to 27.5 V	1,2,3	01,02	70		dB
			M,D,P,L,R,F		1	70	
Output leakage current	ICEX	+IN ≥ 1 V dc, -IN = 0 V, VOUT = 30 V dc	1,2,3	01,02		0.5	μA
			M,D,P,L,R,F		1		

See footnotes at end of table.

<b>STANDARD MICROCIRCUIT DRAWING</b> DLA LAND AND MARITIME COLUMBUS, OHIO 43218-3990	SIZE <b>A</b>		<b>5962-01510</b>
		REVISION LEVEL <b>H</b>	SHEET <b>5</b>

TABLE IA. Electrical performance characteristics - Continued.

Test	Symbol	Conditions <u>1/ 2/</u> -55°C ≤ TA ≤ +125°C +VCC = 9 V  unless otherwise specified	Group A subgroups	Device type	Limits		Unit
					Min	Max	
Output sink current	IOSK	-VIN > 1 V, +VIN = 0 V, VOUT < 1.5 V	1,2,3	01,02	12		mA
			M,D,P,L,R,F		1	12	
Voltage gain	AOL	RL > 15 kΩ, +VCC = 15 V	1,2,3	01,02	25		V/mV
			M,D,P,L,R,F		1	25	
Response time <u>4/</u>	tPHL	VIN = VIO + 5 mV, VREF = 1.4 V, VRL = 5 V, RL = 5.1 kΩ, see figure 3	4,6	01,02		4	μs
			5			6	
			M,D,P,L,R,F		4		
	tPLH	VIN = VIO + 5 mV, VREF = 1.4 V, VRL = 5 V, RL = 5.1 kΩ, see figure 3	4,6			5	μs
			5			7	
			M,D,P,L,R,F		4		

1/ RHA device type 01 supplied to this drawing will meet all levels M, D, P, L, R and F of irradiation. However, device type 01 is only tested at the "F" level accordance with MIL-STD-883 method 1019 condition A (see 1.5 herein). Device type 01 may be dose rate sensitive in a space environment and may demonstrate enhanced low dose rate effects.

RHA device type 02 supplied to this drawing will meet all levels M, D, P, L, R, and F of irradiation for condition A and M, D, P, and L for condition D. However, device type 02 is only tested at the "F" level in accordance with MIL-STD-883, method 1019, condition A and tested at the "L" level in accordance with MIL-STD-883, method 1019, condition D (see 1.5 herein).

Pre and post irradiation values are identical unless otherwise specified in table IA. When performing post irradiation electrical measurements for any RHA level, TA = +25°C.

2/ The comparator will provide a proper output state even if the positive swing of the inputs exceeds the power supply voltage level, if the other input remains within the common mode voltage range. The low input voltage state must not be less than -0.3 V (or 0.3 V below the magnitude of the negative power supply, if used).

3/ The upper end of the common mode voltage range is (+VCC) - 2.5 V, but either or both inputs can go to +30 V without damage.

4/ If not tested, shall be guaranteed to the limits specified in table IA herein.

<b>STANDARD MICROCIRCUIT DRAWING</b> DLA LAND AND MARITIME COLUMBUS, OHIO 43218-3990	SIZE <b>A</b>		<b>5962-01510</b>
		REVISION LEVEL <b>H</b>	SHEET <b>6</b>

TABLE IB. SEP test limits. 1/ 2/

Device types	Bias for No single event burn-out (SEB) test; maximum operating voltage VCC = 30 V at effective LET = 3/ 4/ 5/ [MeV/(mg/cm <sup>2</sup> )]
01, 02	LET ≤ 83

1/ For SEP test conditions, see 4.4.4.2 herein.

2/ Technology characterization and model verification supplemented by in-line data may be used in lieu of end-of-line testing. Test plan must be approved by TRB and qualifying activity.

3/ Tested for latch-up at worst case operating temperature, TA = +125°C ± 10°C

4/ Tested to LET ≤ 83 MeV/(mg/cm<sup>2</sup>) and no latch-up occurs.

5/ Limits are characterized at initial qualification and after any design or process changes which may affect the SEP characteristics but are not production tested. See manufacturer's SEE test report for more information.

3.4 Electrical test requirements. The electrical test requirements shall be the subgroups specified in table IIA. The electrical tests for each subgroup are defined in table IA.

3.5 Marking. The part shall be marked with the PIN listed in 1.2 herein. In addition, the manufacturer's PIN may also be marked. For packages where marking of the entire SMD PIN number is not feasible due to space limitations, the manufacturer has the option of not marking the "5962-" on the device. For RHA product using this option, the RHA designator shall still be marked. Marking for device classes Q and V shall be in accordance with MIL-PRF-38535.

3.5.1 Certification/compliance mark. The certification mark for device classes Q and V shall be a "QML" or "Q" as required in MIL-PRF-38535.

3.6 Certificate of compliance. For device classes Q and V, a certificate of compliance shall be required from a QML-38535 listed manufacturer in order to supply to the requirements of this drawing (see 6.6.1 herein). The certificate of compliance submitted to DLA Land and Maritime-VA prior to listing as an approved source of supply for this drawing shall affirm that the manufacturer's product meets, for device classes Q and V, the requirements of MIL-PRF-38535 and herein.

3.7 Certificate of conformance. A certificate of conformance as required for device classes Q and V in MIL-PRF-38535 shall be provided with each lot of microcircuits delivered to this drawing.

<b>STANDARD MICROCIRCUIT DRAWING</b> DLA LAND AND MARITIME COLUMBUS, OHIO 43218-3990	SIZE <b>A</b>		<b>5962-01510</b>
		REVISION LEVEL H	SHEET 7

Device types	01 and 02
Case outline	X
Terminal number	Terminal symbol
1	NC
2	OUTPUT B
3	NC
4	OUTPUT A
5	NC
6	NC
7	VCC
8	-INPUT A
9	+INPUT A
10	-INPUT B
11	+INPUT B
12	-INPUT C
13	+INPUT C
14	-INPUT D
15	+INPUT D
16	NC
17	GND
18	NC
19	OUTPUT D
20	OUTPUT C

NC = No connection

FIGURE 1. Terminal connections.

<b>STANDARD MICROCIRCUIT DRAWING</b> DLA LAND AND MARITIME COLUMBUS, OHIO 43218-3990	SIZE <b>A</b>		<b>5962-01510</b>
		REVISION LEVEL H	SHEET 8



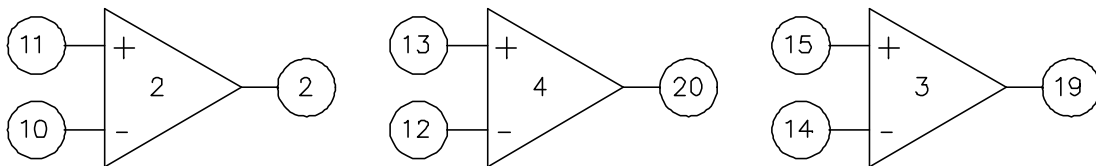
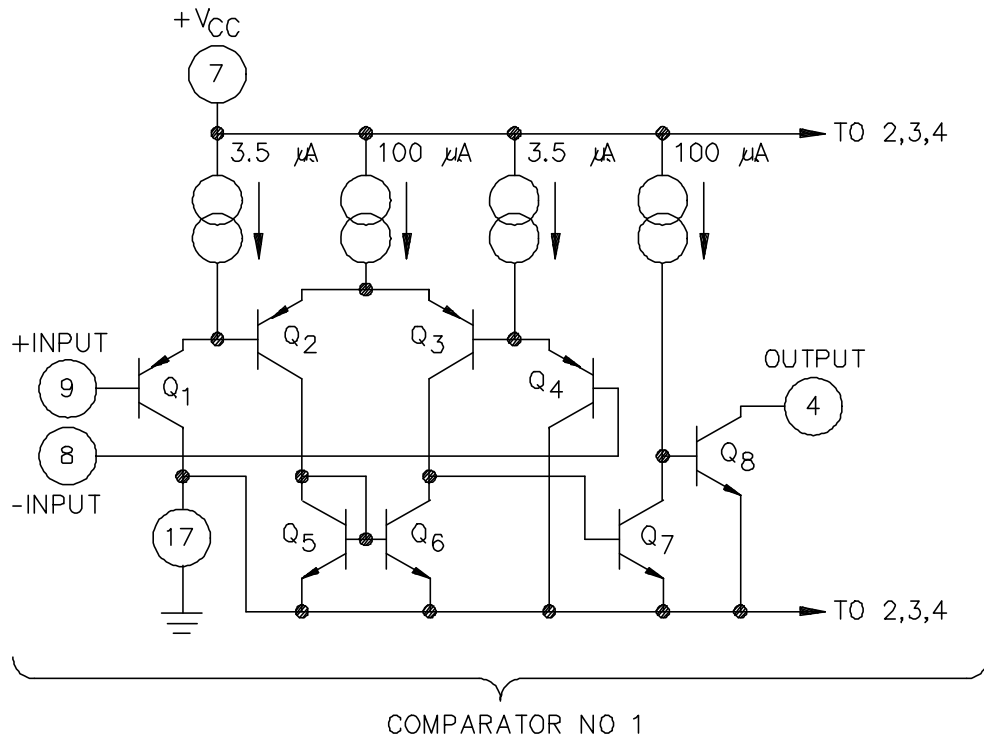

FIGURE 2. Block diagram.

**STANDARD  
MICROCIRCUIT DRAWING**  
DLA LAND AND MARITIME  
COLUMBUS, OHIO 43218-3990

SIZE  
**A**

**5962-01510**

REVISION LEVEL  
**H**

SHEET  
**9**

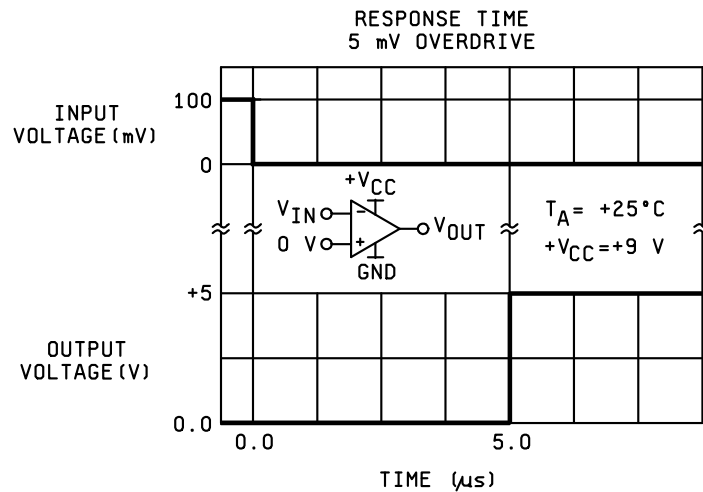
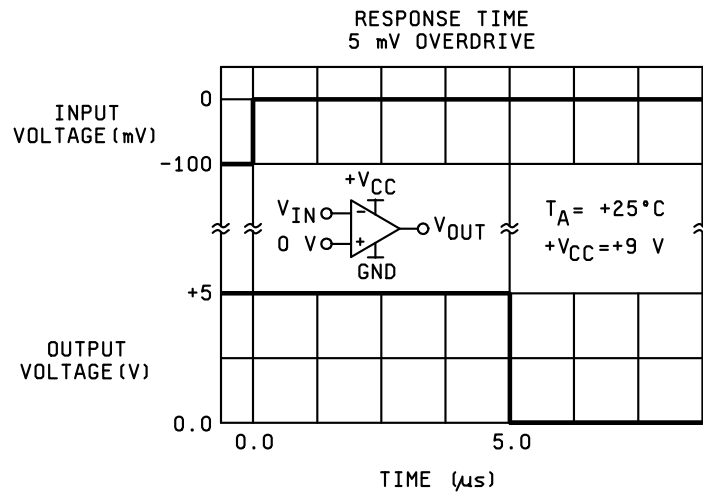

FIGURE 3. Timing diagrams.

**STANDARD  
MICROCIRCUIT DRAWING**  
DLA LAND AND MARITIME  
COLUMBUS, OHIO 43218-3990

SIZE  
**A**

REVISION LEVEL  
H

**5962-01510**

SHEET  
10

4. VERIFICATION

4.1 Sampling and inspection. For device classes Q and V, sampling and inspection procedures shall be in accordance with MIL-PRF-38535 or as modified in the device manufacturer's Quality Management (QM) plan. The modification in the QM plan shall not affect the form, fit, or function as described herein.

4.2 Screening. For device classes Q and V, screening shall be in accordance with MIL-PRF-38535 and shall be conducted on all devices prior to qualification and technology conformance inspection.

4.2.1 Additional criteria for device classes Q and V.

- a. The burn-in test shall be performed in accordance with method 1015 of MIL-STD-883. The burn-in test duration, test condition and test temperature, or approved alternatives shall be as specified in the device manufacturer's QM plan in accordance with MIL-PRF-38535. The burn-in test circuit shall be maintained under document revision level control of the device manufacturer's Technology Review Board (TRB) in accordance with MIL-PRF-38535 and shall be made available to the acquiring or preparing activity upon request. The test circuit shall specify the inputs, outputs, biases, and power dissipation, as applicable, in accordance with the intent specified in method 1015 of MIL-STD-883.
- b. Interim and final electrical test parameters shall be as specified in table IIA herein.
- c. Additional screening for device class V beyond the requirements of device class Q shall be as specified in MIL-PRF-38535, appendix B.

4.3 Qualification inspection for device classes Q and V. Qualification inspection for device classes Q and V shall be in accordance with MIL-PRF-38535. Inspections to be performed shall be those specified in MIL-PRF-38535 and herein for groups A, B, C, D, and E inspections (see 4.4.1 through 4.4.4).

4.4 Conformance inspection. Technology conformance inspection for classes Q and V shall be in accordance with MIL-PRF-38535 including groups A, B, C, D, and E inspections, and as specified herein.

4.4.1 Group A inspection.

- a. Tests shall be as specified in table IIA herein.
- b. Subgroups 7, 8, 9, 10, and 11 in table I, method 5005 of MIL-STD-883 shall be omitted.

4.4.2 Group C inspection. The group C inspection end-point electrical parameters shall be as specified in table IIA herein.

4.4.2.1 Additional criteria for device classes Q and V. The steady-state life test duration, test condition and test temperature, or approved alternatives shall be as specified in the device manufacturer's QM plan in accordance with MIL-PRF-38535. The test circuit shall be maintained under document revision level control by the device manufacturer's TRB in accordance with MIL-PRF-38535 and shall be made available to the acquiring or preparing activity upon request. The test circuit shall specify the inputs, outputs, biases, and power dissipation, as applicable, in accordance with the intent specified in method 1005 of MIL-STD-883.

4.4.3 Group D inspection. The group D inspection end-point electrical parameters shall be as specified in table IIA herein.

<b>STANDARD MICROCIRCUIT DRAWING</b> DLA LAND AND MARITIME COLUMBUS, OHIO 43218-3990	SIZE <b>A</b>		<b>5962-01510</b>
		REVISION LEVEL <b>H</b>	SHEET <b>11</b>

TABLE IIA Electrical test requirements.

Test requirements	Subgroups (in accordance with MIL-PRF-38535, table III)	
	Device class Q	Device class V
Interim electrical parameters (see 4.2)	1,4	1,4
Final electrical parameters (see 4.2)	1,2,3,4,5,6 <u>1/</u>	1,2,3, <u>1/ 2/</u> 4,5,6
Group A test requirements (see 4.4)	1,2,3,4,5,6	1,2,3,4,5,6
Group C end-point electrical parameters (see 4.4)	1,2,3,4,5,6	1,2,3, <u>2/</u> 4,5,6
Group D end-point electrical parameters (see 4.4)	1,4	1,4
Group E end-point electrical parameters (see 4.4)	1,4	1,4

1/ PDA applies to subgroup 1.

2/ Delta limits as specified in table IIB shall be required and the delta values shall be computed with reference to the zero hour electrical parameters (see table IA).

TABLE IIB. Burn-in and life test delta parameters. (TA = +25°C).

Parameters	Symbol	Min	Max	Units
Input offset voltage	V <sub>IO</sub>	-2	+2	mV
Input bias current	±I <sub>IB</sub>	-100	+100	nA
Input offset current	I <sub>IO</sub>	-100	+100	nA

**STANDARD  
MICROCIRCUIT DRAWING**  
DLA LAND AND MARITIME  
COLUMBUS, OHIO 43218-3990

SIZE  
**A**

REVISION LEVEL  
**H**

**5962-01510**

SHEET

12

4.4.4 Group E inspection. Group E inspection is required only for parts intended to be marked as radiation hardness assured (see 3.5 herein).

- a. End-point electrical parameters shall be as specified in table IIA herein.
- b. For device classes Q and V, the devices or test vehicle shall be subjected to radiation hardness assured tests as specified in MIL-PRF-38535 for the RHA level being tested. All device classes must meet the post irradiation end-point electrical parameter limits as defined in table IA at TA = +25°C ±5°C, after exposure, to the subgroups specified in table IIA herein.

4.4.4.1 Total dose irradiation testing. Total dose irradiation testing shall be performed in accordance with MIL-STD-883 method 1019, condition A and as specified herein for device types 01 and 02. In addition, for device type 02 a low dose rate test shall be performed in accordance with MIL-STD-883 method 1019, condition D and as specified herein.

4.4.4.1.1 Accelerated annealing test. Accelerated annealing tests shall be performed on all devices requiring a RHA level greater than 5 krad(Si). The post-anneal end-point electrical parameter limits shall be as specified in table IA herein and shall be the pre-irradiation end-point electrical parameter limit at 25°C ±5°C. Testing shall be performed at initial qualification and after any design or process changes which may affect the RHA response of the device.

4.4.4.2 Single event phenomena (SEP). When specified in the purchase order or contract, SEP testing shall be performed on class V devices. SEP testing shall be performed on the Standard Evaluation Circuit (SEC) or alternate SEP test vehicle as approved by the qualifying activity at initial qualification and after any design or process changes which may affect the upset or latchup characteristics. Test four devices with zero failures. ASTM F1192 may be used as a guideline when performing SEP testing. The recommended test conditions for SEP are as follows:

- a. The ion beam angle of incidence shall be between normal to the die surface and 60° to the normal, inclusive (i.e. 0° ≤ angle ≤ 60°). No shadowing of the ion beam due to fixturing or package related affects is allowed.
- b. The fluence shall be ≥ 100 errors or ≥ 10<sup>7</sup> ions/cm<sup>2</sup>.
- c. The flux shall be between 10<sup>2</sup> and 10<sup>5</sup> ions/cm<sup>2</sup>/s. The cross-section shall be verified to be flux independent by measuring the cross-section at two flux rates which differ by at least an order of magnitude.
- d. The particle range shall be ≥ 20 micron in silicon.
- e. The test temperature shall be +125°C ±10% for SEB.
- f. For SEB test limits, see Table IB herein.

5. PACKAGING

5.1 Packaging requirements. The requirements for packaging shall be in accordance with MIL-PRF-38535 for device classes Q and V.

<b>STANDARD MICROCIRCUIT DRAWING</b> DLA LAND AND MARITIME COLUMBUS, OHIO 43218-3990	SIZE <b>A</b>		<b>5962-01510</b>
		REVISION LEVEL H	SHEET 13

6. NOTES

6.1 Intended use. Microcircuits conforming to this drawing are intended for use for Government microcircuit applications (original equipment), design applications, and logistics purposes.

6.1.1 Replaceability. Microcircuits covered by this drawing will replace the same generic device covered by a contractor prepared specification or drawing.

6.2 Configuration control of SMD's. All proposed changes to existing SMD's will be coordinated with the users of record for the individual documents. This coordination will be accomplished using DD Form 1692, Engineering Change Proposal, or email communication.

6.3 Record of users. Military and industrial users should inform DLA Land and Maritime when a system application requires configuration control and which SMD's are applicable to that system. DLA Land and Maritime will maintain a record of users and this list will be used for coordination and distribution of changes to the drawings. Users of drawings covering microelectronic devices (FSC 5962) should contact DLA Land and Maritime-VA, telephone (614) 692-8108.

6.4 Comments. Comments on this drawing should be directed to DLA Land and Maritime-VA, Columbus, Ohio 43218-3990, or telephone (614) 692-0591.

6.5 Abbreviations, symbols, and definitions. The abbreviations, symbols, and definitions used herein are defined in MIL-PRF-38535 and MIL-HDBK-1331.

6.6 Sources of supply.

6.6.1 Sources of supply for device classes Q and V. Sources of supply for device classes Q and V are listed in MIL-HDBK-103 and QML-38535. The vendors listed in MIL-HDBK-103 and QML-38535 have submitted a certificate of compliance (see 3.6 herein) to DLA Land and Maritime-VA and have agreed to this drawing.

<b>STANDARD MICROCIRCUIT DRAWING</b> DLA LAND AND MARITIME COLUMBUS, OHIO 43218-3990	SIZE <b>A</b>		<b>5962-01510</b>
		REVISION LEVEL H	SHEET 14

APPENDIX A  
APPENDIX A FORMS A PART OF SMD 5962-01510

A.1 SCOPE

A.1.1 Scope. This appendix establishes minimum requirements for microcircuit die to be supplied under the Qualified Manufacturers List (QML) Program. QML microcircuit die meeting the requirements of MIL-PRF-38535 and the manufacturers approved QM plan for use in monolithic microcircuits, multi-chip modules (MCMs), hybrids, electronic modules, or devices using chip and wire designs in accordance with MIL-PRF-38534 are specified herein. Two product assurance classes consisting of military high reliability (device class Q) and space application (device class V) are reflected in the Part or Identification Number (PIN). When available, a choice of Radiation Hardness Assurance (RHA) levels are reflected in the PIN.

A.1.2 PIN. The PIN is as shown in the following example:

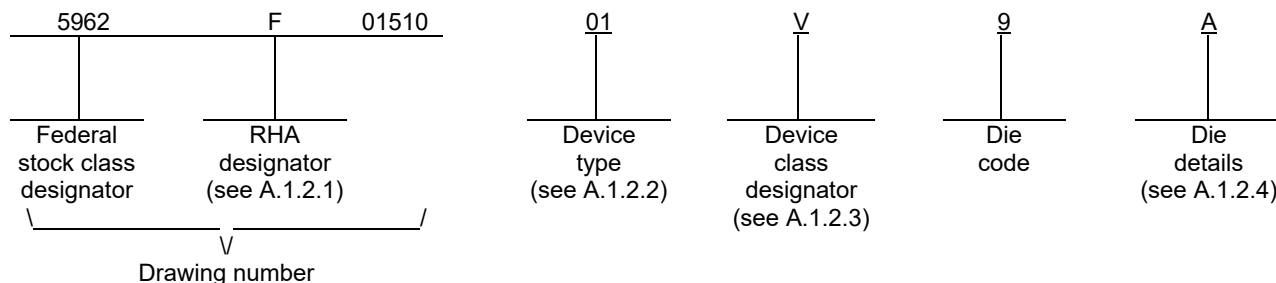

A.1.2.1 RHA designator. Device classes Q and V RHA identified die meet the MIL-PRF-38535 specified RHA levels. A dash (-) indicates a non-RHA die.

A.1.2.2 Device type(s). The device type(s) identify the circuit function as follows:

<u>Device type</u>	<u>Generic number</u>	<u>Circuit function</u>
01	IS-139ASRH	Single event radiation hardened quad voltage comparator
02	IS-139ASEH	Single event radiation hardened quad voltage comparator

A.1.2.3 Device class designator.

<u>Device class</u>	<u>Device requirements documentation</u>
Q or V	Certification and qualification to the die requirements of MIL-PRF-38535

<b>STANDARD MICROCIRCUIT DRAWING</b> DLA LAND AND MARITIME COLUMBUS, OHIO 43218-3990	SIZE <b>A</b>		<b>5962-01510</b>
		REVISION LEVEL H	SHEET 15

APPENDIX A  
APPENDIX A FORMS A PART OF SMD 5962-01510

A.1.2.4 Die details. The die details designation is a unique letter which designates the die's physical dimensions, bonding pad location(s) and related electrical function(s), interface materials, and other assembly related information, for each product and variant supplied to this appendix.

A.1.2.4.1 Die physical dimensions.

<u>Die type</u>	<u>Figure number</u>
01, 02	A-1

A.1.2.4.2 Die bonding pad locations and electrical functions.

<u>Die type</u>	<u>Figure number</u>
01, 02	A-1

A.1.2.4.3 Interface materials.

<u>Die type</u>	<u>Figure number</u>
01, 02	A-1

A.1.2.4.4 Assembly related information.

<u>Die type</u>	<u>Figure number</u>
01, 02	A-1

A.1.3 Absolute maximum ratings. See paragraph 1.3 herein for details.

A.1.4 Recommended operating conditions. See paragraph 1.4 herein for details.

A.1.5 Radiation features. See paragraph 1.5 herein for details.

<b>STANDARD MICROCIRCUIT DRAWING</b> DLA LAND AND MARITIME COLUMBUS, OHIO 43218-3990	SIZE <b>A</b>	<b>5962-01510</b>
	REVISION LEVEL H	SHEET 16



APPENDIX A  
APPENDIX A FORMS A PART OF SMD 5962-01510

A.2 APPLICABLE DOCUMENTS.

A.2.1 Government specification, standards, and handbooks. The following specification, standards, and handbooks form a part of this drawing to the extent specified herein. Unless otherwise specified, the issues of these documents are those cited in the solicitation or contract.

DEPARTMENT OF DEFENSE SPECIFICATION

MIL-PRF-38535 - Integrated Circuits, Manufacturing, General Specification for.

DEPARTMENT OF DEFENSE STANDARD

MIL-STD-883 - Test Method Standard Microcircuits.

DEPARTMENT OF DEFENSE HANDBOOKS

MIL-HDBK-103 - List of Standard Microcircuit Drawings.

MIL-HDBK-780 - Standard Microcircuit Drawings.

(Copies of these documents are available online at <https://quicksearch.dla.mil>).

A.2.2 Order of precedence. In the event of a conflict between the text of this drawing and the references cited herein, the text of this drawing takes precedence. Nothing in this document, however, supersedes applicable laws and regulations unless a specific exemption has been obtained.

A.3 REQUIREMENTS

A.3.1 Item requirements. The individual item requirements for device classes Q and V shall be in accordance with MIL-PRF-38535 and as specified herein or as modified in the device manufacturer's Quality Management (QM) plan. The modification in the QM plan shall not affect the form, fit, or function as described herein.

A.3.2 Design, construction and physical dimensions. The design, construction, and physical dimensions shall be as specified in MIL-PRF-38535 and herein and the manufacturer's QM plan for device classes Q and V.

A.3.2.1 Die physical dimensions. The die physical dimensions shall be as specified in A.1.2.4.1 and on figure A-1.

A.3.2.2 Die bonding pad locations and electrical functions. The die bonding pad locations and electrical functions shall be as specified in A.1.2.4.2 and on figure A-1.

A.3.2.3 Interface materials. The interface materials for the die shall be as specified in A.1.2.4.3 and on figure A-1.

A.3.2.4 Assembly related information. The assembly related information shall be as specified in A.1.2.4.4 and on figure A-1.

A.3.2.5 Radiation exposure circuit. The radiation exposure circuit shall be as defined in paragraph 3.2.5 herein.

A.3.3 Electrical performance characteristics and post-irradiation parameter limits. Unless otherwise specified herein, the electrical performance characteristics and post-irradiation parameter limits are as specified in table IA of the body of this document.

A.3.4 Electrical test requirements. The wafer probe test requirements shall include functional and parametric testing sufficient to make the packaged die capable of meeting the electrical performance requirements in table IA.

A.3.5 Marking. As a minimum, each unique lot of die, loaded in single or multiple stack of carriers, for shipment to a customer, shall be identified with the wafer lot number, the certification mark, the manufacturer's identification and the PIN listed in A.1.2 herein. The certification mark shall be a "QML" or "Q" as required by MIL-PRF-38535.

<b>STANDARD MICROCIRCUIT DRAWING</b> DLA LAND AND MARITIME COLUMBUS, OHIO 43218-3990	SIZE <b>A</b>		<b>5962-01510</b>
		REVISION LEVEL H	SHEET 17

APPENDIX A  
APPENDIX A FORMS A PART OF SMD 5962-01510

A.3.6 Certification of compliance. For device classes Q and V, a certificate of compliance shall be required from a QML-38535 listed manufacturer in order to supply to the requirements of this drawing (see A.6.4 herein). The certificate of compliance submitted to DLA Land and Maritime -VA prior to listing as an approved source of supply for this appendix shall affirm that the manufacturer's product meets, for device classes Q and V, the requirements of MIL-PRF-38535 and the requirements herein.

A.3.7 Certificate of conformance. A certificate of conformance as required for device classes Q and V in MIL-PRF-38535 shall be provided with each lot of microcircuit die delivered to this drawing.

A.4 VERIFICATION

A.4.1 Sampling and inspection. For device classes Q and V, die sampling and inspection procedures shall be in accordance with MIL-PRF-38535 or as modified in the device manufacturer's Quality Management (QM) plan. The modifications in the QM plan shall not affect the form, fit, or function as described herein.

A.4.2 Screening. For device classes Q and V, screening shall be in accordance with MIL-PRF-38535, and as defined in the manufacturer's QM plan. As a minimum, it shall consist of:

- a. Wafer lot acceptance for class V product using the criteria defined in MIL-STD-883, method 5007.
- b. 100% wafer probe (see paragraph A.3.4 herein).
- c. 100% internal visual inspection to the applicable class Q or V criteria defined in MIL-STD-883, method 2010 or the alternate procedures allowed in MIL-STD-883, method 5004.

A.4.3 Conformance inspection.

A.4.3.1 Group E inspection. Group E inspection is required only for parts intended to be identified as radiation assured (see A.3.5 herein). RHA levels for device classes Q and V shall be as specified in MIL-PRF-38535. End point electrical testing of packaged die shall be as specified in table IIA herein. Group E tests and conditions are as specified in paragraphs 4.4.4, 4.4.4.1, 4.4.4.1.1, and 4.4.4.2 herein.

A.5 DIE CARRIER

A.5.1 Die carrier requirements. The requirements for the die carrier shall be accordance with the manufacturer's QM plan or as specified in the purchase order by the acquiring activity. The die carrier shall provide adequate physical, mechanical and electrostatic protection.

A.6 NOTES

A.6.1 Intended use. Microcircuit die conforming to this drawing are intended for use in microcircuits built in accordance with MIL-PRF-38535 or MIL-PRF-38534 for government microcircuit applications (original equipment), design applications, and logistics purposes.

A.6.2 Comments. Comments on this appendix should be directed to DLA Land and Maritime -VA, Columbus, Ohio, 43218-3990 or telephone (614)-692-0591.

A.6.3 Abbreviations, symbols, and definitions. The abbreviations, symbols, and definitions used herein are defined in MIL-PRF-38535 and MIL-HDBK-1331.

A.6.4 Sources of supply for device classes Q and V. Sources of supply for device classes Q and V are listed in QML-38535. The vendors listed within MIL-HDBK-103 and QML-38535 have submitted a certificate of compliance (see A.3.6 herein) to DLA Land and Maritime -VA and have agreed to this drawing.

<b>STANDARD MICROCIRCUIT DRAWING</b> DLA LAND AND MARITIME COLUMBUS, OHIO 43218-3990	SIZE <b>A</b>		<b>5962-01510</b>
		REVISION LEVEL <b>H</b>	SHEET <b>18</b>

APPENDIX A  
 APPENDIX A FORMS A PART OF SMD 5962-01510

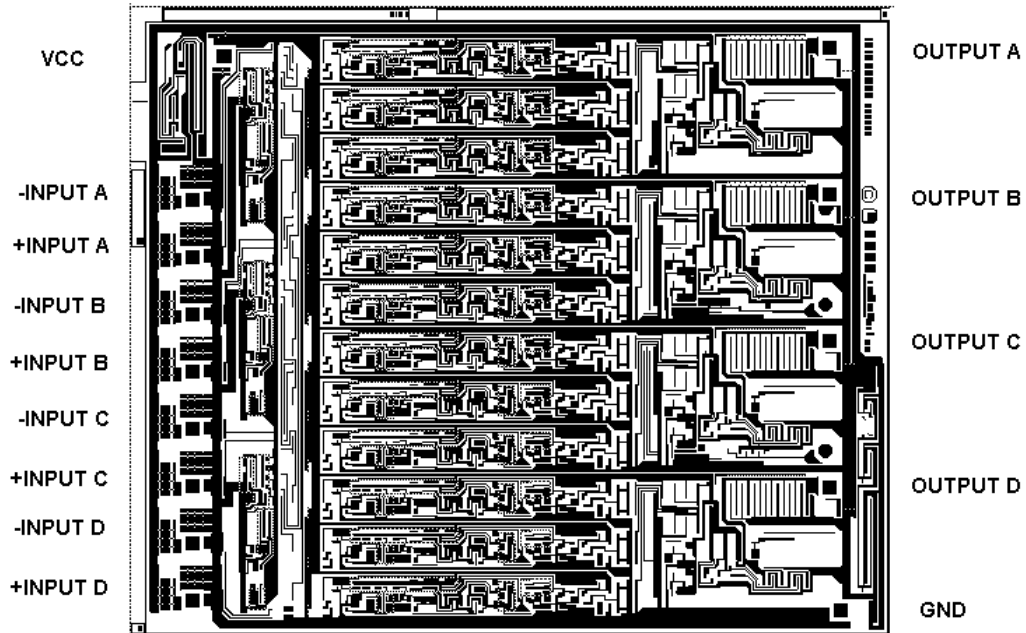

NOTE: Pad numbers reflect terminal numbers when placed in case outline X (see figure 1).

Die physical dimensions.

Die size: 3750 microns x 4510 microns  
 Die thickness: 19 ±1 mils

Interface materials.

Top metallization: Al Si Cu 16.0 kÅ ±2 kÅ  
 Backside metallization: Silicon

Glassivation.

Type: Silox (SiO<sub>2</sub>)  
 Thickness: 8.0 kÅ ±1.0 kÅ

Substrate: Dielectrically Isolated (D.I.)

Assembly related information.

Substrate potential: Unbiased  
 Special assembly instructions: None

FIGURE A-1. Die bonding pad locations and electrical functions.

<b>STANDARD          MICROCIRCUIT DRAWING</b> DLA LAND AND MARITIME COLUMBUS, OHIO 43218-3990	SIZE <b>A</b>		<b>5962-01510</b>
		REVISION LEVEL <b>H</b>	SHEET 19

STANDARD MICROCIRCUIT DRAWING BULLETIN

DATE: 24-02-26

Approved sources of supply for SMD 5962-01510 are listed below for immediate acquisition information only and shall be added to MIL-HDBK-103 and QML-38535 during the next revision. MIL-HDBK-103 and QML-38535 will be revised to include the addition or deletion of sources. The vendors listed below have agreed to this drawing and a certificate of compliance has been submitted to and accepted by DLA Land and Maritime-VA. This information bulletin is superseded by the next dated revision of MIL-HDBK-103 and QML-38535. DLA Land and Maritime maintains an online database of all current sources of supply at <https://landandmaritimeapps.dla.mil/programs/smcr/>.

Standard microcircuit drawing PIN <u>1/</u>	Vendor CAGE number	Vendor similar PIN <u>2/</u>
5962F0151001QXC	34371	IS9-139ASRH-8
5962F0151001VXC	34371	IS9-139ASRH-Q
5962F0151001V9A	34371	IS0-139ASRH-Q
5962F0151002VXC	34371	IS9-139ASEH-Q
5962F0151002V9A	34371	IS0-139ASEH-Q

- 1/ The lead finish shown for each PIN representing a hermetic package is the most readily available from the manufacturer listed for that part. If the desired lead finish is not listed contact the vendor to determine its availability.
- 2/ Caution. Do not use this number for item acquisition. Items acquired to this number may not satisfy the performance requirements of this drawing.

Vendor CAGE number

34371

Vendor name and address

Renesas Electronics America, Inc.  
1650 Robert J. Conlan Blvd. NE  
Palm Bay, FL 32905-3406

The information contained herein is disseminated for convenience only and the Government assumes no liability whatsoever for any inaccuracies in the information bulletin.