

**REVISIONS**

LTR	DESCRIPTION	DATE (YR-MO-DA)	APPROVED
A	Sheet 4: Table I, conditions block, delete " $V_S = \pm 5 V$ " and substitute " $V_S = +5 V$ ". Table I, nonlinearity (NL) test, conditions column, delete "-55°C to +150°C with ambient error (E) set to zero. 1/ 2", and substitute "-55°C to +150°C". Sheet 5: Table I, conditions block, delete " $V_S = \pm 5 V$ " and substitute " $V_S = +5 V$ ". Sheet 6: Figure 1, case outline X, add "NOTE: Top view". Changes in accordance with NOR 5962-R036-93.	92-12-23	M. A. Frye
B	Change boilerplate to add one-part numbers. Add table IIB for delta limits. Editorial changes throughout. Redrawn	97-03-07	R. Monnin
C	Add radiation hardness assurance requirements. Update boilerplate. -rrp	98-06-18	R. Monnin
D	Changes to 1.5, table IIB, and 4.4.4.1. -rrp	99-04-12	R. Monnin
E	Changes to table IIA footnotes and table IIB. -rrp	00-09-15	R. Monnin
F	Add device type 04 to the post irradiation value for the ambient error test in table I. Update boilerplate. -rrp	02-05-24	R. Monnin
G	Add paragraph 4.4.4.1. Editorial changes throughout. -rrp	07-05-14	Robert M. Heber
H	Add device type 05. Delete figure 4 radiation exposure circuit. - ro	13-01-14	C. Saffle
J	Update drawing to current MIL-PRF-38535 requirements. - jch	19-03-01	C. Saffle



THE ORIGINAL FIRST PAGE OF THIS DRAWING HAS BEEN REPLACED.

REV																			
SHEET																			
REV																			
SHEET																			

REV STATUS	REV	J	J	J	J	J	J	J	J	J	J	J	J	J	J	J
OF SHEETS	SHEET	1	2	3	4	5	6	7	8	9	10	11	12	13	14	

PMIC N/A	PREPARED BY Marcia B. Kelleher	<p align="center"><b>DLA LAND AND MARITIME</b>                  COLUMBUS, OHIO 43218-3990  <a href="https://www.dla.mil/landandmaritime">https://www.dla.mil/landandmaritime</a></p>													
<p align="center"><b>STANDARD MICROCIRCUIT DRAWING</b></p> <p align="center">THIS DRAWING IS AVAILABLE FOR USE BY ALL DEPARTMENTS AND AGENCIES OF THE DEPARTMENT OF DEFENSE</p> <p align="center">AMSC N/A</p>	CHECKED BY D. A. DiCenzo														
	APPROVED BY Nelson Hauck	<p align="center">MICROCIRCUIT, LINEAR, RADIATION HARDENED, TWO TERMINAL TEMPERATURE TRANSDUCER, MONOLITHIC SILICON</p>													
	DRAWING APPROVAL DATE 87-09-21														
	REVISION LEVEL J	SIZE A	CAGE CODE <b>67268</b>	<b>5962-87571</b>											
		SHEET 1 OF 14													

1. SCOPE

1.1 Scope. This drawing documents two product assurance class levels consisting of high reliability (device class Q and M) and space application (device class V). A choice of case outlines and lead finishes are available and are reflected in the Part or Identifying Number (PIN). When available, a choice of Radiation Hardness Assurance (RHA) levels is reflected in the PIN.

1.2 PIN. The PIN is as shown in the following examples.

For device class M and Q:

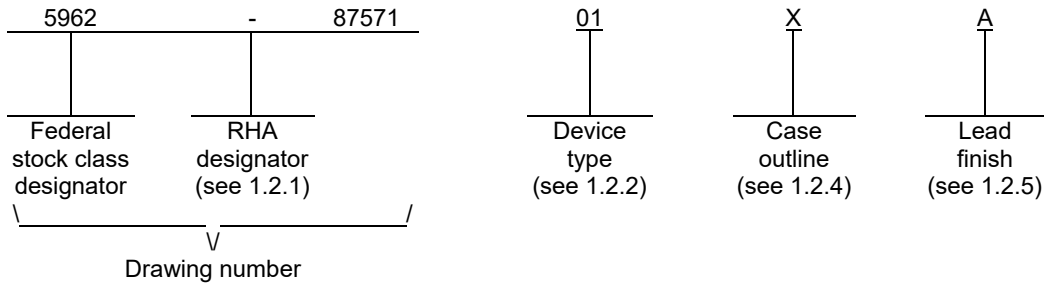

For device class V:

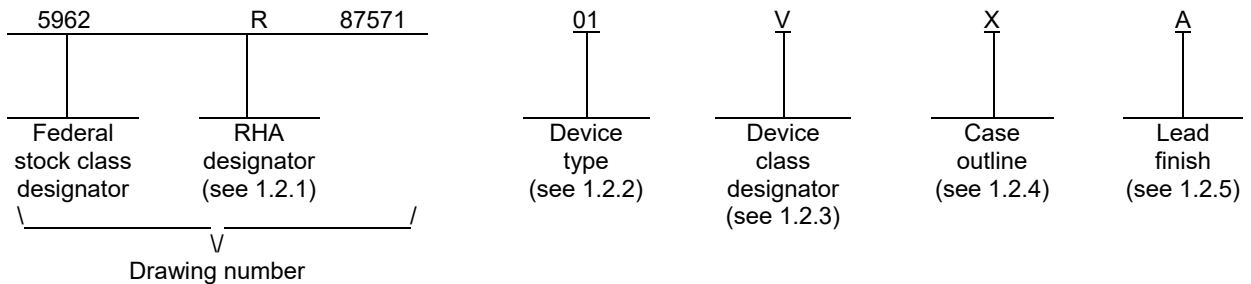

1.2.1 RHA designator. Device classes Q and V RHA marked devices meet the MIL-PRF-38535 specified RHA levels and are marked with the appropriate RHA designator. Device class M RHA marked devices meet the MIL-PRF-38535, appendix A specified RHA levels and are marked with the appropriate RHA designator. A dash (-) indicates a non-RHA device.

1.2.2 Device type(s). The device type(s) identify the circuit function as follows:

<u>Device type</u>	<u>Generic number</u>	<u>Circuit function</u>
01	AD590J	Temperature transducer
02	AD590K	Temperature transducer
03	AD590L	Temperature transducer
04	AD590M	Temperature transducer
05	AD590M	Temperature transducer

1.2.3 Device class designator. The device class designator is a single letter identifying the product assurance level as listed below. Since the device class designator has been added after the original issuance of this drawing, device classes M and Q designators will not be included in the PIN and will not be marked on the device.

<u>Device class</u>	<u>Device requirements documentation</u>
M	Vendor self-certification to the requirements for MIL-STD-883 compliant, non-JAN class level B microcircuits in accordance with MIL-PRF-38535, appendix A
Q or V	Certification and qualification to MIL-PRF-38535

<b>STANDARD MICROCIRCUIT DRAWING</b> DLA LAND AND MARITIME COLUMBUS, OHIO 43218-3990	SIZE <b>A</b>		<b>5962-87571</b>
		REVISION LEVEL <b>J</b>	SHEET <b>2</b>

1.2.4 Case outline(s). The case outline(s) are as designated in MIL-STD-1835 and as follows:

<u>Outline letter</u>	<u>Descriptive designator</u>	<u>Terminals</u>	<u>Package style</u>
X	See figure 1	2	Flat package
Y	See figure 1	3	Metal Can

1.2.5 Lead finish. The lead finish is as specified in MIL-PRF-38535 for device classes Q and V or MIL-PRF-38535, appendix A for device class M.

1.3 Absolute maximum ratings. 1/

Forward voltage (E+ to E-)	+44 V dc
Reverse voltage (E+ to E-)	-20 V dc
Breakdown voltage (case to E+ or E-)	±200 V dc
Rated performance temperature range	-55°C to +150°C 2/
Storage performance temperature range	-65°C to +155°C
Lead temperature range (soldering, 10 seconds)	+300°C
Thermal resistance (θJA):	

MEDIUM	θJC + θCA (°C/W)		TS 3/	
	Y 4/	X 4/	Y 4/	X 4/
Aluminum block	30	10	0.6	0.1
Stirred oil 5/	42	60	1.4	0.6
Moving air 6/				
with heat sink	45	---	5.0	---
without heat sink	115	190	13.5	10.0
Still air				
with heat sink	191	---	108	---
without heat sink	480	650	60	30

1.4 Recommended operating conditions.

Supply voltage range (V <sub>cc</sub> )	4 V dc to 30 V dc
Operating ambient temperature range	-55°C to +150°C 2/

1/ Stresses above the absolute maximum rating may cause permanent damage to the device. Extended operation at the maximum levels may degrade performance and affect reliability.

2/ Device types 02, 03, 04, and 05 class V rated performance temperature range = -55°C to +125°C.

3/ The time constant is defined as the time required to reach 63.2 percent of an instantaneous temperature change.

4/ Y – 3-pin can; X – 2-pin flat package.

5/ T is dependent upon velocity of oil: average of several velocities listed above.

6/ Air velocity = 9 feet per second.

<b>STANDARD MICROCIRCUIT DRAWING</b> DLA LAND AND MARITIME COLUMBUS, OHIO 43218-3990	SIZE <b>A</b>		<b>5962-87571</b>
		REVISION LEVEL J	SHEET <b>3</b>

1.5 Radiation features.

Maximum total dose available (dose rate = 50 – 300 rads(Si)/s):

Device class V:

Device types 03 and 04 ..... 100 krads(Si) 7/

Maximum total dose available (dose rate ≤ 10 mrad(Si)/s):

Device class V:

Device type 05 ..... 50 krads(Si) 7/

2. APPLICABLE DOCUMENTS

2.1 Government specification, standards, and handbooks. The following specification, standards, and handbooks form a part of this drawing to the extent specified herein. Unless otherwise specified, the issues of these documents are those cited in the solicitation or contract.

DEPARTMENT OF DEFENSE SPECIFICATION

MIL-PRF-38535 - Integrated Circuits, Manufacturing, General Specification for.

DEPARTMENT OF DEFENSE STANDARDS

MIL-STD-883 - Test Method Standard Microcircuits.

MIL-STD-1835 - Interface Standard Electronic Component Case Outlines.

DEPARTMENT OF DEFENSE HANDBOOKS

MIL-HDBK-103 - List of Standard Microcircuit Drawings.

MIL-HDBK-780 - Standard Microcircuit Drawings.

(Copies of these documents are available online at <https://quicksearch.dla.mil>.)

2.2 Order of precedence. In the event of a conflict between the text of this drawing and the references cited herein, the text of this drawing takes precedence. Nothing in this document, however, supersedes applicable laws and regulations unless a specific exemption has been obtained.

3. REQUIREMENTS

3.1 Item requirements. The individual item requirements for device classes Q and V shall be in accordance with MIL-PRF-38535 and as specified herein or as modified in the device manufacturer's Quality Management (QM) plan. The modification in the QM plan shall not affect the form, fit, or function as described herein. The individual item requirements for device class M shall be in accordance with MIL-PRF-38535, appendix A for non-JAN class level B devices and as specified herein.

3.2 Design, construction, and physical dimensions. The design, construction, and physical dimensions shall be as specified in MIL-PRF-38535 and herein for device classes Q and V or MIL-PRF-38535, appendix A and herein for device class M.

3.2.1 Case outlines. The case outlines shall be in accordance with 1.2.4 herein and figures 1 and 2.

3.2.2 Terminal connections. The terminal connections shall be as specified on figure 3.

3.2.3 Radiation exposure circuit. The radiation exposure circuit shall be maintained by the manufacturer under document revision level control and shall be made available to the preparing and acquiring activity upon request.

7/ Device types 03 and 04 may be dose rate sensitive in a space environment and may demonstrate en rate effects. Radiation end point limits for the noted parameters are guaranteed only for the condition MIL-STD-883, method 1019, condition A for device types 03 and 04, condition D for device type 05.

<b>STANDARD MICROCIRCUIT DRAWING</b> DLA LAND AND MARITIME COLUMBUS, OHIO 43218-3990	SIZE <b>A</b>		<b>5962-87571</b>
		REVISION LEVEL <b>J</b>	SHEET <b>4</b>

3.3 Electrical performance characteristics and postirradiation parameter limits. Unless otherwise specified herein, the electrical performance characteristics and postirradiation parameter limits are as specified in table I and shall apply over the full ambient operating temperature range.

3.4 Electrical test requirements. The electrical test requirements shall be the subgroups specified in table IIA. The electrical tests for each subgroup are defined in table I.

3.5 Marking. The part shall be marked with the PIN listed in 1.2 herein. In addition, the manufacturer's PIN may also be marked. For packages where marking of the entire SMD PIN number is not feasible due to space limitations, the manufacturer has the option of not marking the "5962-" on the device. For RHA product using this option, the RHA designator shall still be marked. Marking for device classes Q and V shall be in accordance with MIL-PRF-38535. Marking for device class M shall be in accordance with MIL-PRF-38535, appendix A.

3.5.1 Certification/compliance mark. The certification mark for device classes Q and V shall be a "QML" or "Q" as required in MIL-PRF-38535. The compliance mark for device class M shall be a "C" as required in MIL-PRF-38535, appendix A.

3.6 Certificate of compliance. For device classes Q and V, a certificate of compliance shall be required from a QML-38535 listed manufacturer in order to supply to the requirements of this drawing (see 6.6.1 herein). For device class M, a certificate of compliance shall be required from a manufacturer in order to be listed as an approved source of supply in MIL-HDBK-103 (see 6.6.2 herein). The certificate of compliance submitted to DLA Land and Maritime-VA prior to listing as an approved source of supply for this drawing shall affirm that the manufacturer's product meets, for device classes Q and V, the requirements of MIL-PRF-38535 and herein or for device class M, the requirements of MIL-PRF-38535, appendix A and herein.

3.7 Certificate of conformance. A certificate of conformance as required for device classes Q and V in MIL-PRF-38535 or for device class M in MIL-PRF-38535, appendix A shall be provided with each lot of microcircuits delivered to this drawing.

3.8 Notification of change for device class M. For device class M, notification to DLA Land and Maritime-VA of change of product (see 6.2 herein) involving devices acquired to this drawing is required for any change that affects this drawing.

3.9 Verification and review for device class M. For device class M, DLA Land and Maritime, DLA Land and Maritime's agent, and the acquiring activity retain the option to review the manufacturer's facility and applicable required documentation. Offshore documentation shall be made available onshore at the option of the reviewer.

3.10 Microcircuit group assignment for device class M. Device class M devices covered by this drawing shall be in microcircuit group number 59 (see MIL-PRF-38535, appendix A).

<b>STANDARD MICROCIRCUIT DRAWING</b> DLA LAND AND MARITIME COLUMBUS, OHIO 43218-3990	SIZE <b>A</b>		<b>5962-87571</b>
		REVISION LEVEL <b>J</b>	SHEET <b>5</b>

TABLE I. Electrical performance characteristics.

Test	Symbol	Conditions <u>1/ 2/</u> -55°C ≤ T <sub>A</sub> ≤ +125°C V <sub>S</sub> = +5 V unless otherwise specified	Group A subgroups	Device type	Limits		Unit
					Min	Max	
Ambient error	E	Nominal output current is 298.15 μA at +25°C	1	All		5.0	±°C
			12	01		5.0	
			12	02		2.5	
			12	03		1.0	
			12	04, 05		0.5	
				M,D,P,L,R	12	03, 04	
	M, D, P, L	12	05	-10.0	1.0		
Absolute error	E <sub>A</sub>	-55°C to +150°C without external calibration <u>3/</u>	2, 3	01		10	±°C
		-55°C to +125°C without external calibration <u>3/</u>	2, 3	02		5.5	
			2, 3	03		3	
			2, 3	04, 05		1.7	
Calibrated absolute error	E <sub>C</sub>	-55°C to +150°C with ambient error (E) set to zero. <u>3/ 4/</u>	2, 3	01		3	±°C
		-55°C to +125°C without external calibration. <u>3/ 4/</u>	2, 3	02		2	
			2, 3	03		1.6	
			2, 3	04, 05		1	
Nonlinearity	NL	-55°C to +150°C <u>3/ 4/ 5/</u>	2, 3	01		1.5	±°C
		-55°C to +125°C without external calibration. <u>3/ 4/ 5/</u>	2, 3	02		0.8	
			2, 3	03		0.4	
			2, 3	04, 05		0.3	
Repeatability	RPT	Max deviation between +25°C readings after temperature. Cycling between -55°C and +150°C. <u>3/ 5/ 6/</u>	1, 2, 3	All		0.1	±°C
Long-term drift	ΔE/ΔT	Constant +5 V; Constant +125°C <u>3/ 5/</u>		All		0.1	±°C/ month

See footnotes at end of table.

<b>STANDARD MICROCIRCUIT DRAWING</b> DLA LAND AND MARITIME COLUMBUS, OHIO 43218-3990	SIZE <b>A</b>		<b>5962-87571</b>
		REVISION LEVEL <b>J</b>	SHEET <b>6</b>

TABLE I. Electrical performance characteristics – Continued.

Test	Symbol	Conditions <u>1/ 2/</u> -55°C ≤ T <sub>A</sub> ≤ +125°C V <sub>S</sub> = +5 V unless otherwise specified	Group A subgroups	Device type	Limits		Unit
					Min	Max	
Power supply rejection ratio	PSRR	+4 V ≤ V <sub>S</sub> ≤ +5 V <u>3/ 5/</u>	1	All		1	°C/V
		+5 V ≤ V <sub>S</sub> ≤ +15 V <u>3/ 5/</u>				0.4	
		+15 V ≤ V <sub>S</sub> ≤ +30 V <u>3/ 5/</u>				0.2	
Power supply voltage range	V <sub>S</sub>	<u>3/ 5/</u>	1	All	+4		V
						+30	

- 1/ Device types 03 and 04 supplied to this drawing have been characterized through all levels P, L, R of irradiation. Device type 05 supplied to this drawing has been characterized through all levels P and L of irradiation. However, device types 03 and 04 are only tested at the "R" and device type 05 is only tested at the "L" level. Pre and Post irradiation values are identical unless otherwise specified in Table I.
- 2/ Device types 03 and 04 may be dose rate sensitive in a space environment and may demonstrate enhanced low dose rate effects. Radiation end point limits for the noted parameters are guaranteed only for the conditions specified in MIL-STD-883, method 1019, condition A for device types 03 and 04 and condition D for device type 05.
- 3/ This parameter is not tested post-irradiation.
- 4/ See figure 4.
- 5/ Guaranteed if not tested.
- 6/ For device types 02, 03, 04, and 05 class V maximum temperature = +125°C.

<b>STANDARD MICROCIRCUIT DRAWING</b> DLA LAND AND MARITIME COLUMBUS, OHIO 43218-3990	SIZE <b>A</b>		<b>5962-87571</b>
		REVISION LEVEL <b>J</b>	SHEET <b>7</b>

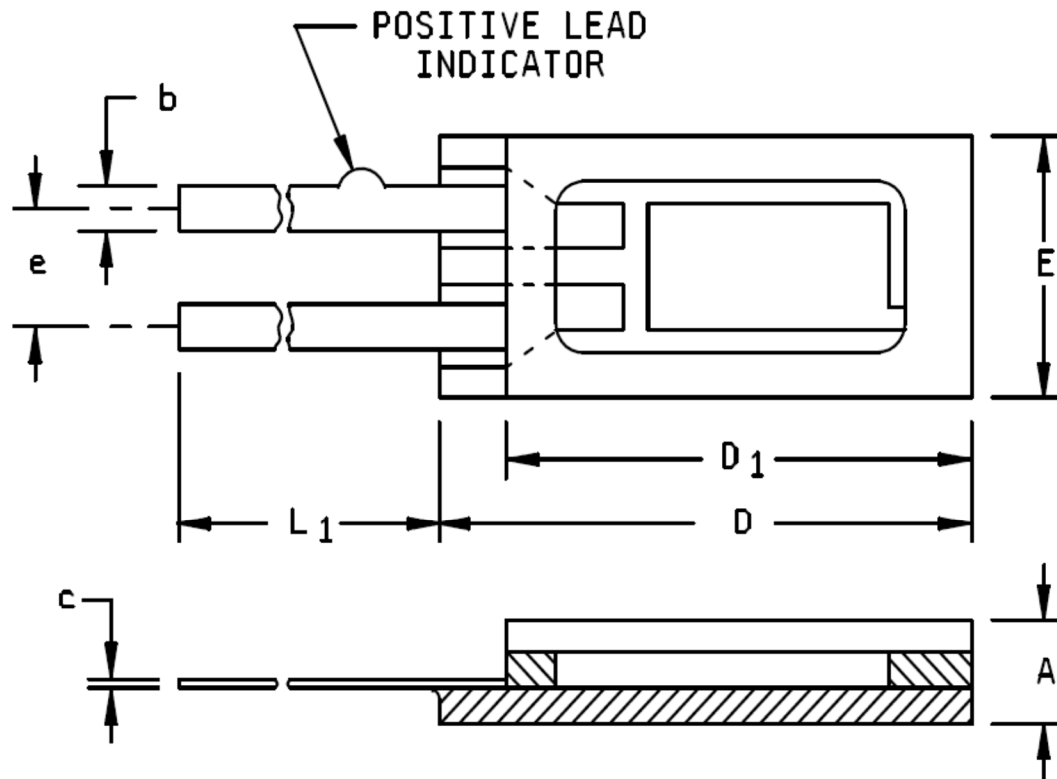

Symbol	Inches		Millimeters		Notes
	Min	Max	Min	Max	
A	0.041	0.050	1.04	1.27	
b	0.015	0.019	0.38	0.48	
c	0.0045	0.0065	0.12	0.17	
D	---	0.250	---	6.35	2
D <sub>1</sub>	---	0.220	---	5.59	
E	0.081	0.093	2.06	2.36	2
e	0.045	0.056	1.14	1.40	
L <sub>1</sub>	0.500	---	12.69	---	

NOTES:

1. The US government preferred system of measurement is the metric SI system. However, this item was originally designed using inch-pound units of measurement. In the event of conflict between the metric and inch-pound units, the inch-pound units shall take precedence.
2. This dimension allows for off-center lid, meniscus and solder overrun.
3. Top view.

FIGURE 1. Case outline X (2-lead, 0.087" x 0.250" flat package).

<b>STANDARD MICROCIRCUIT DRAWING</b> DLA LAND AND MARITIME COLUMBUS, OHIO 43218-3990	SIZE <b>A</b>		<b>5962-87571</b>
		REVISION LEVEL <b>J</b>	SHEET <b>8</b>



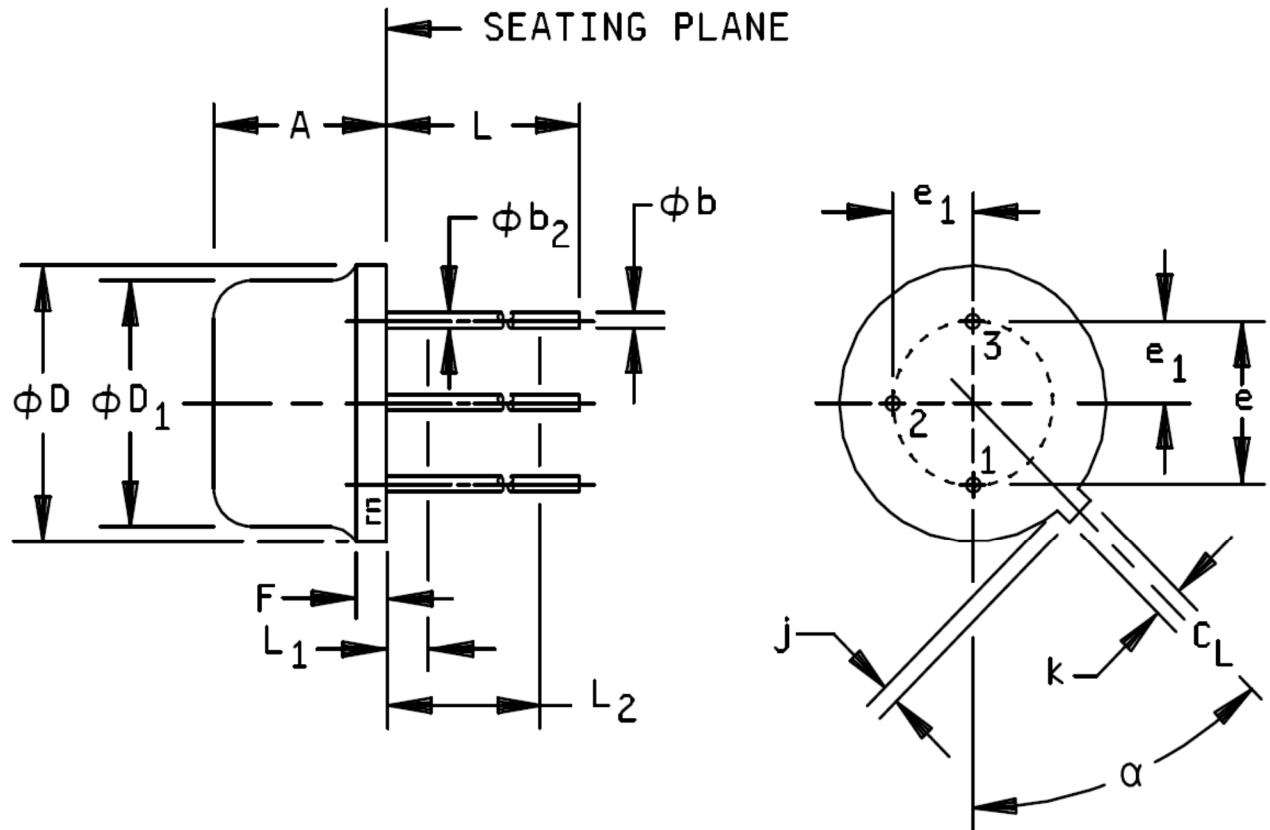

FIGURE 2. Case outline Y (3-lead metal can).

**STANDARD  
MICROCIRCUIT DRAWING**  
DLA LAND AND MARITIME  
COLUMBUS, OHIO 43218-3990

SIZE  
**A**

**5962-87571**

REVISION LEVEL  
**J**

SHEET  
**9**

Symbol	Inches		Millimeters		Notes
	Min	Max	Min	Max	
A	0.115	0.150	2.92	3.81	
$\phi b$	---	0.021	---	0.53	2, 5
$\phi b_2$	0.016	0.019	0.41	0.48	2, 5
$\phi D$	0.209	0.230	5.31	5.84	
$\phi D_1$	0.178	0.195	4.52	4.95	
e	0.100 BSC		2.54 BSC		3
e <sub>1</sub>	0.050 BSC		1.27 BSC		3
F	---	0.030	---	0.76	
j	0.036	0.046	0.91	1.17	
k	0.028	0.048	0.71	1.22	4
L	0.500	---	12.70	---	2
L <sub>1</sub>	---	0.050	---	1.27	2
L <sub>2</sub>	0.250	---	6.35	---	
$\alpha$	45° BSC		45° BSC		

NOTES:

1. The US government preferred system of measurement is the metric SI system. However, this item was originally designed using inch-pound units of measurement. In the event of conflict between the metric and inch-pound units, the inch-pound units shall take precedence.
2. (Three leads)  $\phi b_2$  applies between L<sub>1</sub> and L<sub>2</sub>.  $\phi b$  applies between L<sub>2</sub> and 0.5 inch (12.70 mm) from seating plane. Diameter is uncontrolled in L<sub>1</sub> and beyond 0.5 inch (12.70 mm) from seating plane.
3. Leads having maximum diameter 0.019 inch (0.48 mm) measured in gauging plane 0.054 inch (1.4 mm) + 0.001 inch (0.03 mm) - 0.000 inch (0.00 mm) below the seating plane of the device are within 0.007 inch (0.18 mm) of their true positions relative to a maximum-width tab.
4. Measured from maximum diameter of the actual device.
5. All leads: Increase maximum limit by 0.003 inch (0.08 mm) when hot solder dip finish is applied.

FIGURE 2. Case outline Y (3-lead metal can) – Continued.

<b>STANDARD MICROCIRCUIT DRAWING</b> DLA LAND AND MARITIME COLUMBUS, OHIO 43218-3990	SIZE <b>A</b>		<b>5962-87571</b>
		REVISION LEVEL <b>J</b>	SHEET <b>10</b>

Device types	01, 02, 03, 04	01, 02, 03, 04, 05
Case outlines	X	Y
Terminal number	Terminal symbol	
1	+	+
2	-	-
3	---	NC

NC = No connect

FIGURE 3. Terminal connections.

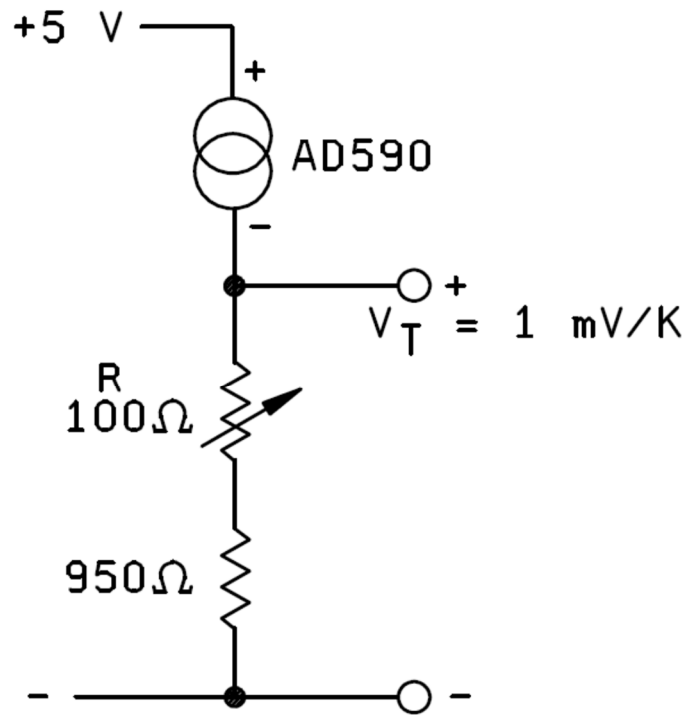

NOTE:  $V_s$  across device must remain constant or PSRR error must be included.

FIGURE 4. One temperature trim.

<b>STANDARD MICROCIRCUIT DRAWING</b> DLA LAND AND MARITIME COLUMBUS, OHIO 43218-3990	SIZE <b>A</b>		<b>5962-87571</b>
		REVISION LEVEL <b>J</b>	SHEET <b>11</b>

4. VERIFICATION

4.1 Sampling and inspection. For device classes Q and V, sampling and inspection procedures shall be in accordance with MIL-PRF-38535 or as modified in the device manufacturer's Quality Management (QM) plan. The modification in the QM plan shall not affect the form, fit, or function as described herein. For device class M, sampling and inspection procedures shall be in accordance with MIL-PRF-38535, appendix A.

4.2 Screening. For device classes Q and V, screening shall be in accordance with MIL-PRF-38535, and shall be conducted on all devices prior to qualification and technology conformance inspection. For device class M, screening shall be in accordance with method 5004 of MIL-STD-883, and shall be conducted on all devices prior to quality conformance inspection.

4.2.1 Additional criteria for device class M.

- a. Burn-in test, method 1015 of MIL-STD-883.
  - (1) Test condition A, B, C, or D. The test circuit shall be maintained by the manufacturer under document revision level control and shall be made available to the preparing or acquiring activity upon request. The test circuit shall specify the inputs, outputs, biases, and power dissipation, as applicable, in accordance with the intent specified in method 1015.
  - (2) T<sub>A</sub> = +125°C, minimum.
- b. Interim and final electrical test parameters shall be as specified in table IIA herein.

4.2.2 Additional criteria for device classes Q and V.

- a. The burn-in test duration, test condition and test temperature, or approved alternatives shall be as specified in the device manufacturer's QM plan in accordance with MIL-PRF-38535. The burn-in test circuit shall be maintained under document revision level control of the device manufacturer's Technology Review Board (TRB) in accordance with MIL-PRF-38535 and shall be made available to the acquiring or preparing activity upon request. The test circuit shall specify the inputs, outputs, biases, and power dissipation, as applicable, in accordance with the intent specified in method 1015 of MIL-STD-883.
- b. Interim and final electrical test parameters shall be as specified in table IIA herein.
- c. Additional screening for device class V beyond the requirements of device class Q shall be as specified in MIL-PRF-38535, appendix B.

4.3 Qualification inspection for device classes Q and V. Qualification inspection for device classes Q and V shall be in accordance with MIL-PRF-38535. Inspections to be performed shall be those specified in MIL-PRF-38535 and herein for groups A, B, C, D, and E inspections (see 4.4.1 through 4.4.4).

4.4 Conformance inspection. Technology conformance inspection for classes Q and V shall be in accordance with MIL-PRF-38535 including groups A, B, C, D, and E inspections and as specified. Quality conformance inspection for device class M shall be in accordance with MIL-PRF-38535, appendix A and as specified herein. Inspections to be performed for device class M shall be those specified in method 5005 of MIL-STD-883 and herein for groups A, B, C, D, and E inspections (see 4.4.1 through 4.4.4).

4.4.1 Group A inspection.

- a. Tests shall be as specified in table IIA herein.
- b. Subgroups 4, 5, 6, 7, 8, 9, 10, and 11 in table I, method 5005 of MIL-STD-883 shall be omitted.
- c. Optional subgroup 12 is used for grading and part selection at +25°C, it is not included in PDA.

<b>STANDARD MICROCIRCUIT DRAWING</b> DLA LAND AND MARITIME COLUMBUS, OHIO 43218-3990	SIZE <b>A</b>		<b>5962-87571</b>
		REVISION LEVEL <b>J</b>	SHEET <b>12</b>

TABLE IIA. Electrical test requirements.

Test requirements	Subgroups (in accordance with MIL-STD-883, method 5005, table I)	Subgroups (in accordance with MIL-PRF-38535, table III)	
	Device class M	Device class Q	Device class V
Interim electrical parameters (see 4.2)	---	---	---
Final electrical parameters (see 4.2)	1, 2, 3, 12 <u>1/</u>	1, 2, 3, 12 <u>1/</u>	1, 2, 3, 12 <u>1/ 2/</u>
Group A test requirements (see 4.4)	1, 2, 3, 12	1, 2, 3, 12	1, 2, 3, 12
Group C end-point electrical parameters (see 4.4)	1	1	1 <u>2/</u>
Group D end-point electrical parameters (see 4.4)	1	1	1
Group E end-point electrical parameters (see 4.4)	---	---	1

1/ PDA applies to subgroup 1. Delta's excluded from PDA.

2/ Delta limits in accordance with table IIB shall be computed with reference to the previous interim electrical parameters.

TABLE IIB. 240 hour burn-in and group C end-point electrical parameters.

Parameter	Device types	Burn-in endpoint	Burn-in delta	Group C endpoint	Group C delta	Units
Ambient error (E)	02	2.5	0.5	3.5	1.0	±°C
	03	1.0	0.5	2.0	1.0	±°C
	04	0.5	0.5	1.5	1.0	±°C
	05	0.5	0.5	1.5	1.0	±°C

4.4.2 Group C inspection. The group C inspection end-point electrical parameters shall be as specified in table IIA herein.

4.4.2.1 Additional criteria for device class M. Steady-state life test conditions, method 1005 of MIL-STD-883:

- a. Test condition A, B, C, or D. The test circuit shall be maintained by the manufacturer under document revision level control and shall be made available to the preparing or acquiring activity upon request. The test circuit shall specify the inputs, outputs, biases, and power dissipation, as applicable, in accordance with the intent specified in method 1005 of MIL-STD-883.
- b.  $T_A = +125^\circ\text{C}$ , minimum.
- c. Test duration: 1,000 hours, except as permitted by method 1005 of MIL-STD-883.

<b>STANDARD MICROCIRCUIT DRAWING</b> DLA LAND AND MARITIME COLUMBUS, OHIO 43218-3990	SIZE <b>A</b>		<b>5962-87571</b>
		REVISION LEVEL <b>J</b>	SHEET <b>13</b>

4.4.2.2 Additional criteria for device classes Q and V. The steady-state life test duration, test condition and test temperature, or approved alternatives shall be as specified in the device manufacturer's QM plan in accordance with MIL-PRF-38535. The test circuit shall be maintained under document revision level control by the device manufacturer's TRB in accordance with MIL-PRF-38535 and shall be made available to the acquiring or preparing activity upon request. The test circuit shall specify the inputs, outputs, biases, and power dissipation, as applicable, in accordance with the intent specified in method 1005 of MIL-STD-883.

4.4.3 Group D inspection. The group D inspection end-point electrical parameters shall be as specified in table IIA herein.

4.4.4 Group E inspection. Group E inspection is required only for parts intended to be marked as radiation hardness assured (see 3.5 herein).

- a. End-point electrical parameters shall be as specified in table IIA herein.
- b. For device classes Q and V, the devices or test vehicle shall be subjected to radiation hardness assured tests as specified in MIL-PRF-38535 for the RHA level being tested. For device class M, the devices shall be subjected to radiation hardness assured tests as specified in MIL-PRF-38535, appendix A for the RHA level being tested. All device classes must meet the postirradiation end-point electrical parameter limits as defined in table I at  $T_A = +25^{\circ}\text{C} \pm 5^{\circ}\text{C}$ , after exposure, to the subgroups specified in table IIA herein.

## 5. PACKAGING

5.1 Packaging requirements. The requirements for packaging shall be in accordance with MIL-PRF-38535 for device classes Q and V or MIL-PRF-38535, appendix A for device class M.

## 6. NOTES

6.1 Intended use. Microcircuits conforming to this drawing are intended for use for Government microcircuit applications (original equipment), design applications, and logistics purposes.

6.1.1 Replaceability. Microcircuits covered by this drawing will replace the same generic device covered by a contractor-prepared specification or drawing.

6.2 Configuration control of SMD's. All proposed changes to existing SMD's will be coordinated with the users of record for the individual documents. This coordination will be accomplished using DD Form 1692, Engineering Change Proposal.

6.3 Record of users. Military and industrial users should inform DLA Land and Maritime when a system application requires configuration control and which SMD's are applicable to that system. DLA Land and Maritime will maintain a record of users and this list will be used for coordination and distribution of changes to the drawings. Users of drawings covering microelectronic devices (FSC 5962) should contact DLA Land and Maritime-VA, telephone (614) 692-8108.

6.4 Comments. Comments on this drawing should be directed to DLA Land and Maritime-VA, Columbus, Ohio 43218-3990, or telephone (614) 692-0540.

6.5 Abbreviations, symbols, and definitions. The abbreviations, symbols, and definitions used herein are defined in MIL-PRF-38535 and MIL-HDBK-1331.

### 6.6 Sources of supply.

6.6.1 Sources of supply for device classes Q and V. Sources of supply for device classes Q and V are listed in MIL-HDBK-103 and QML-38535. The vendors listed in MIL-HDBK-103 and QML-38535 have submitted a certificate of compliance (see 3.6 herein) to DLA Land and Maritime-VA and have agreed to this drawing.

6.6.2 Approved sources of supply for device class M. Approved sources of supply for class M are listed in MIL-HDBK-103. The vendors listed in MIL-HDBK-103 have agreed to this drawing and a certificate of compliance (see 3.6 herein) has been submitted to and accepted by DLA Land and Maritime-VA.

<b>STANDARD MICROCIRCUIT DRAWING</b> DLA LAND AND MARITIME COLUMBUS, OHIO 43218-3990	SIZE <b>A</b>		<b>5962-87571</b>
		REVISION LEVEL <b>J</b>	SHEET <b>14</b>

STANDARD MICROCIRCUIT DRAWING BULLETIN

DATE: 19-03-01

Approved sources of supply for SMD 5962-87571 are listed below for immediate acquisition information only and shall be added to MIL-HDBK-103 and QML-38535 during the next revision. MIL-HDBK-103 and QML-38535 will be revised to include the addition or deletion of sources. The vendors listed below have agreed to this drawing and a certificate of compliance has been submitted to and accepted by DLA Land and Maritime-VA. This information bulletin is superseded by the next dated revision of MIL-HDBK-103 and QML-38535. DLA Land and Maritime maintains an online database of all current sources of supply at <https://landandmaritimeapps.dla.mil/programs/smcr/>.

Standard microcircuit drawing PIN 1/	Vendor CAGE number	Vendor similar PIN 2/
5962-8757101XA	24355 (2)	AD590JF/883B
5962-8757101YA	24355 (2)	AD590JH/883B
5962-8757102XA	24355 (2)	AD590KF/883B
5962-8757102YA	24355 (2)	AD590KH/883B
5962-8757102VXA	<u>3/</u>	AD590KF/QMLV
5962-8757102VYA	<u>3/</u>	AD590KH/QMLV
5962-8757103XA	24355 (2)	AD590LF/883B
5962-8757103YA	24355 (2)	AD590LH/883B
5962-8757103VXA	<u>3/</u>	AD590LF/QMLV
5962-8757103VYA	<u>3/</u>	AD590LH/QMLV
5962R8757103VXA	24355 (4)	AD590LF/QMLR
5962R8757103VYA	24355 (4)	AD590LH/QMLR
5962-8757104XA	24355 (2)	AD590MF/883B
5962-8757104YA	24355 (2)	AD590MH/883B
5962-8757104VXA	<u>3/</u>	AD590MF/QMLV
5962-8757104VYA	<u>3/</u>	AD590MH/QMLV
5962R8757104VXA	24355 (4)	AD590MF/QMLR
5962R8757104VXC	24355 (4)	AD590MF/QMLR
5962R8757104VYA	24355 (4)	AD590MH/QMLR
5962L8757105VYA	24355 (4)	AD590MH/QMLL

1/ The lead finish shown for each PIN representing a hermetic package is the most readily available from the manufacturer listed for that part. If the desired lead finish is not listed contact the vendor to determine its availability.

2/ Caution. Do not use this number for item acquisition. Items acquired to this number may not satisfy the performance requirements of this drawing.

3/ Not available from an approved source of supply.

STANDARD MICROCIRCUIT DRAWING BULLETIN – CONTINUED.

DATE: 19-03-01

Vendor CAGE  
number

Vendor name  
and address

24355

Analog Devices (2)  
RT 1 Industrial Park  
PO Box 9106  
Norwood, MA 02062  
Point of contact: 804 Woburn Street  
Wilmington, MA 01887-3462

24355

Analog Devices (4)  
RT 1 Industrial Park  
PO Box 9106  
Norwood, MA 02062  
Point of contact: 7910 Triad Center Drive  
Greensboro, NC 27409-9605

The information contained herein is disseminated for convenience only and the Government assumes no liability whatsoever for any inaccuracies in the information bulletin.