

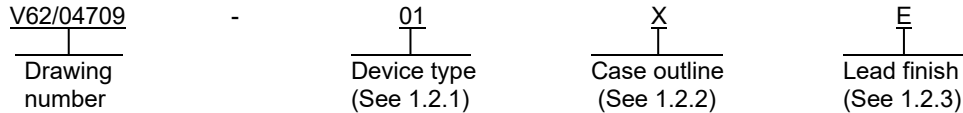

1. SCOPE

1.1 Scope. This drawing documents the general requirements of a high performance 3.3-V ABT 16-bit bus transceiver with 3-state outputs microcircuit, with an operating temperature range of -40°C to +85°C and extended operating temperature range of -55°C to +125°C.

1.2 Vendor Item Drawing Administrative Control Number. The manufacturer's PIN is the item of identification. The vendor item drawing establishes an administrative control number for identifying the item on the engineering documentation:



1.2.1 Device type(s).

<u>Device type</u>	<u>Generic</u>	<u>Circuit function</u>
01 <u>1/</u>	SN74LVTH162245-EP	3.3-V ABT 16-bit bus transceiver with 3-state outputs
02 <u>2/</u>	SN74LVTH162245-EP	3.3-V ABT 16-bit bus transceiver with 3-state outputs

1.2.2 Case outline. The case outline are as specified herein.

<u>Outline letter</u>	<u>Number of pins</u>	<u>JEDEC PUB 95</u>	<u>Package style</u>
X	48	MO-153	Plastic small-outline
Y	48	MO-118	Plastic small-outline

1.2.3 Lead finishes. The lead finishes are as specified below or other lead finishes as provided by the device manufacturer:

<u>Finish designator</u>	<u>Material</u>
A	Hot solder dip
B	Tin-lead plate
C	Gold plate
D	Palladium
E	Gold flash palladium
Z	Other

1/ Operates at -40°C to +85°C.  
2/ Operates at -55°C to +125°C.

<b>DLA LAND AND MARITIME COLUMBUS, OHIO</b>	<b>SIZE A</b>	<b>CAGE CODE 16236</b>	<b>DWG NO. V62/04709</b>
		<b>REV C</b>	<b>PAGE 2</b>

1.3 Absolute maximum ratings. 3/

Supply voltage range ( $V_{CC}$ ) .....	-0.5 V to 4.6 V
Input voltage range ( $V_i$ ) .....	-0.5 V to 7 V 4/
Voltage range applied to any output in the high-impedance or power-off state ( $V_o$ ) .....	-0.5 V to 7 V 4/
Voltage range applied to any output in the high state ( $V_o$ ) .....	-0.5 V to $V_{CC} + 0.5 V$ 4/
Current into any output in the low state ( $I_o$ ):	
(B port) .....	128 mA
(A port) .....	30 mA
Current into any output in the high state ( $I_o$ ): 5/	
(B port) .....	64 mA
(A port) .....	30 mA
Input clamp current ( $I_{IK}$ ) ( $V_i < 0$ ) .....	-50 mA
Output clamp current ( $I_{OK}$ ) ( $V_o < 0$ ) .....	-50 mA
Package thermal impedance ( $\theta_{JA}$ ): 6/	
Case X .....	70°C/W
Case Y .....	95°C/W
Storage temperature range ( $T_{STG}$ ) .....	-65°C to 150°C

1.4 Recommended operating conditions. 7/

Supply voltage range ( $V_{CC}$ ) .....	2.7 V to 3.6 V
Minimum high level input voltage ( $V_{IH}$ ) .....	2.0 V
Maximum low level input voltage ( $V_{IL}$ ) .....	0.8 V
Maximum input voltage ( $V_i$ ) .....	5.5 V
Maximum high level output current ( $I_{OH}$ ):	
(A port) .....	-12 mA
(B port) .....	-32 mA
Maximum low level output current ( $I_{OL}$ ):	
(A port) .....	12 mA
(B port) .....	64 mA
Maximum input transition rise or fall rate ( $\Delta t/\Delta v$ ) (Outputs enabled) .....	10 ns/V
Minimum power-up ramp rate ( $\Delta t/\Delta V_{CC}$ ) .....	200 $\mu$ s/V
Operating free-air temperature range ( $T_A$ ):	
Device type 01 .....	-40°C to +85°C
Device type 02 .....	-55°C to +125°C

2. APPLICABLE DOCUMENTS

SOLID STATE TECHNOLOGY ASSOCIATION (JEDEC)

- JEDEC PUB 95 – Registered and Standard Outlines for Semiconductor Devices
- JESD 51-7 – High Effective Thermal Conductivity Test Board for Leaded Surface Mount Packages

(Copies of these documents are available online at <https://www.jedec.org>.)

- 3/ Stresses beyond those listed under “absolute maximum ratings” may cause permanent damage to the device. These are stress ratings only, and functional operation of the device at these or any other conditions beyond those indicated under “recommended operating conditions” is not implied. Exposure to absolute-maximum-rated conditions for extended periods may affect device reliability.
- 4/ The input and output negative-voltage ratings may be exceeded if the input and output clamp-current ratings are observed.
- 5/ This current flows only when the output is in the high state and  $V_o > V_{CC}$ .
- 6/ The package thermal impedance is calculated in accordance with JESD 51-7.
- 7/ All unused control inputs of the device must be held at  $V_{CC}$  or GND to ensure proper device operation.

<b>DLA LAND AND MARITIME COLUMBUS, OHIO</b>	<b>SIZE A</b>	<b>CAGE CODE 16236</b>	<b>DWG NO. V62/04709</b>
		REV C	PAGE 3

3. REQUIREMENTS

3.1 Marking. Parts shall be permanently and legibly marked with the manufacturer's part number as shown in 6.3 herein and as follows:

- A. Manufacturer's name, CAGE code, or logo
- B. Pin 1 identifier
- C. ESDS identification (optional)

3.2 Unit container. The unit container shall be marked with the manufacturer's part number and with items A and C (if applicable) above.

3.3 Electrical characteristics. The maximum and recommended operating conditions and electrical performance characteristics are as specified in 1.3, 1.4, and table I herein.

3.4 Design, construction, and physical dimension. The design, construction, and physical dimensions are as specified herein.

3.5 Diagrams.

3.5.1 Case outline. The case outline shall be as shown in 1.2.2 and figure 1.

3.5.2 Truth table. The truth table shall be as shown in figure 2.

3.5.3 Logic diagram. The logic diagram shall be as shown in figure 3.

3.5.4 Terminal connections. The terminal connections shall be as shown in figure 4.

3.5.5 Test circuit and timing waveforms. The test circuit and timing waveforms shall be as shown in figure 5.

<b>DLA LAND AND MARITIME COLUMBUS, OHIO</b>	<b>SIZE A</b>	<b>CAGE CODE 16236</b>	<b>DWG NO. V62/04709</b>
		REV C	PAGE 4

TABLE I. Electrical performance characteristics. 1/

Test	Symbol	Conditions -40°C ≤ T <sub>A</sub> ≤ +85°C 2/ -55°C ≤ T <sub>A</sub> ≤ +125°C 3/ 4/	V <sub>CC</sub>	Device type	Limits		Unit	
					Min	Max		
Input clamp voltage	V <sub>IK</sub>	I <sub>I</sub> = -18 mA	2.7 V	All		-1.2	V	
High level output voltage	A port	V <sub>OH</sub>	I <sub>OH</sub> = -100 μA		2.7 V to 3.6 V	V <sub>CC</sub> - 0.2		V
			I <sub>OH</sub> = -12 mA		3.0 V	2		
	B port	V <sub>OH</sub>	I <sub>OH</sub> = -100 μA		2.7 V to 3.6 V	V <sub>CC</sub> - 0.2		
			I <sub>OH</sub> = -8 mA		2.7 V	2.4		
			I <sub>OH</sub> = -32 mA		3.0 V	2		
Low level output voltage	A port	V <sub>OL</sub>	I <sub>OL</sub> = 100 μA		2.7 V to 3.6 V		0.2	V
			I <sub>OL</sub> = 12 mA		3.0 V		0.8	
	B port	V <sub>OL</sub>	I <sub>OL</sub> = 100 μA		2.7 V		0.2	
			I <sub>OL</sub> = 24 mA		2.7 V		0.5	
			I <sub>OL</sub> = 16 mA		3.0 V		0.4	
			I <sub>OL</sub> = 32 mA		3.0 V		0.5	
			I <sub>OL</sub> = 64 mA		3.0 V		0.55	
Input current	Control inputs	I <sub>I</sub>	V <sub>I</sub> = V <sub>CC</sub> or GND	3.6 V		±1	μA	
			V <sub>I</sub> = 5.5 V	0 V or 3.6 V		10		
	A or B port 5/	V <sub>I</sub> = 5.5 V	3.6 V			20		
				V <sub>I</sub> = V <sub>CC</sub>		5		
				V <sub>I</sub> = 0		-10		
Input/output power-off leakage current	I <sub>off</sub>	V <sub>I</sub> or V <sub>O</sub> = 0 to 4.5 V	0 V			±100	μA	
Input current (hold)	A or B port	I <sub>I(hold)</sub>	V <sub>I</sub> = 0.8 V	3.0 V	75		μA	
			V <sub>I</sub> = 2 V		-75			
			V <sub>I</sub> = 0 V to 3.6 V	3.6 V 6/		500 -750		
3-state output current power-up		V <sub>O</sub> = 0.5 V to 3 V, OE= don't care	0 V to 1.5 V			±100	μA	
3-state output current power-down			1.5 V to 0 V			±100	μA	
Quiescent supply current	I <sub>CC</sub>	I <sub>O</sub> = 0, V <sub>I</sub> = V <sub>CC</sub> or GND Outputs high	3.6 V			0.19	mA	
						I <sub>O</sub> = 0, V <sub>I</sub> = V <sub>CC</sub> or GND Outputs low		5
						I <sub>O</sub> = 0, V <sub>I</sub> = V <sub>CC</sub> or GND Output disabled		0.19
Quiescent supply current delta	ΔI <sub>CC</sub> 7/	One input at V <sub>CC</sub> - 0.6 V, Other inputs at V <sub>CC</sub> or GND	3.0 V to 3.6 V			0.2	mA	
						0.3		
Input capacitance	C <sub>i</sub>	V <sub>I</sub> = 3 V or 0 V, T <sub>A</sub> = 25°C	3.3 V	All	4 Typ		pF	
Input/output capacitance	C <sub>i/o</sub>	V <sub>O</sub> = 3 V or 0 V, T <sub>A</sub> = 25°C	3.3 V		10 Typ			

See footnotes at end of table.

<b>DLA LAND AND MARITIME COLUMBUS, OHIO</b>	<b>SIZE A</b>	<b>CAGE CODE 16236</b>	<b>DWG NO. V62/04709</b>
		REV C	PAGE 5

TABLE I. Electrical performance characteristics - Continued.

Test	Symbol	Device Type 01				Device Type 02				Unit
		$V_{CC} = 3.3\text{ V}$ $\pm 0.3\text{ V}$		$V_{CC} = 2.7\text{ V}$		$V_{CC} = 3.3\text{ V}$ $\pm 0.3\text{ V}$		$V_{CC} = 2.7\text{ V}$		
		Min	Max	Min	Max	Min	Max	Min	Max	
Switching characteristics <u>4/</u> (see figure 5)										
Propagation delay time, from input A to output B	t <sub>PLH</sub>	1	3.3		3.7	1	3.5		4	ns
	t <sub>PHL</sub>	1	3.3		3.5	1	3.5		3.9	
Propagation delay time, from input B to output A	t <sub>PLH</sub>	1	4		4.6	1	4.3		5.3	
	t <sub>PHL</sub>	1	3.4		3.6	1	4.2		4.5	
Enable time, from input $\overline{OE}$ to output B	t <sub>PZH</sub>	1	4.6		5.4	1	4.8		5.9	
	t <sub>PZL</sub>	1	4.6		5.2	1	4.8		5.5	
Enable time, from input $\overline{OE}$ to output A	t <sub>PZH</sub>	1	5.3		6.3	1	5.5		7.2	
	t <sub>PZL</sub>	1	5.1		5.8	1	7.2		6.4	
Disable time, from input $\overline{OE}$ to output B	t <sub>PHZ</sub>	1.5	5.2		5.5	1.5	6.4		5.8	
	t <sub>PLZ</sub>	1.5	5.1		5.4	1.5	5.8		5.8	
Disable time, from input $\overline{OE}$ to output A	t <sub>PHZ</sub>	1.5	5.6		5.9	1.5	5.8		6.5	
	t <sub>PLZ</sub>	1.5	5.5		5.5	1.2	6.3		6.3	
Output skew time	t <sub>sk(o)</sub>		0.5							

- 1/ Testing and other quality control techniques are used to the extent deemed necessary to assure product performance over the specified temperature range. Product may not necessarily be tested across the full temperature range and all parameters may not necessarily be tested. In the absence of specific parametric testing, product performance is assured by characterization and/or design.
- 2/ For device type 01.
- 3/ For device type 02.
- 4/ Over recommended operating free air temperature range (unless otherwise noted).
- 5/ Unused terminals are at  $V_{CC}$  or GND.
- 6/ This is the bus-hold maximum dynamic current. It is the minimum overdrive current required to switch the input from one state to another.
- 7/ This is the increase in supply current for each input that is at the specified TTL voltage level, rather than  $V_{CC}$  or GND.

<b>DLA LAND AND MARITIME COLUMBUS, OHIO</b>	<b>SIZE A</b>	<b>CAGE CODE 16236</b>	<b>DWG NO. V62/04709</b>
		REV C	PAGE 6

Case X

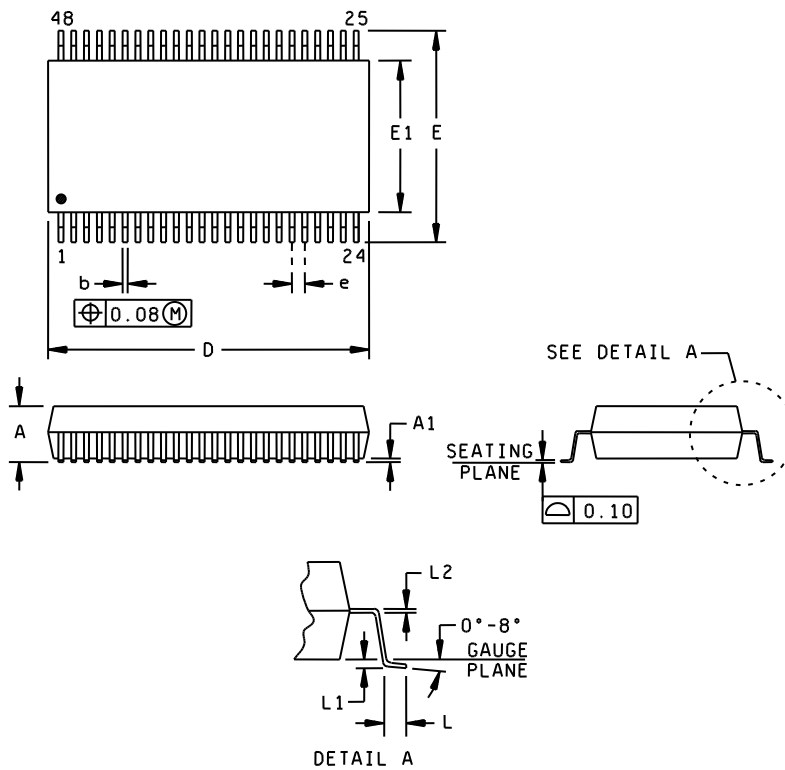

Dimensions									
Symbol	Millimeters		Inches		Symbol	Millimeters		Inches	
	Min	Max	Min	Max		Min	Max	Min	Max
A	---	1.20	---	.047	E1	6.00	6.20	.236	.244
A1	0.05	0.15	.002	.006	e	0.50 BSC		.020 BSC	
b	0.17	0.27	.007	.011	L	0.50	0.75	.020	.030
D	12.40	12.60	.488	.496	L1	0.25 TYP		.010 TYP	
E	7.90	8.30	.311	.327	L2	0.15 NOM		.006 NOM	

NOTES:

1. All linear dimensions are in millimeters (inches).
2. This case outline is subject to change without notice.
3. Body dimensions do not include mold flash or protrusion, not to exceed 0.15 millimeters (0.006 in).
4. Fall within JEDEC MO-153.

FIGURE 1. Case outline.

DLA LAND AND MARITIME COLUMBUS, OHIO	SIZE A	CAGE CODE 16236	DWG NO. V62/04709
		REV C	PAGE 7

Case Y

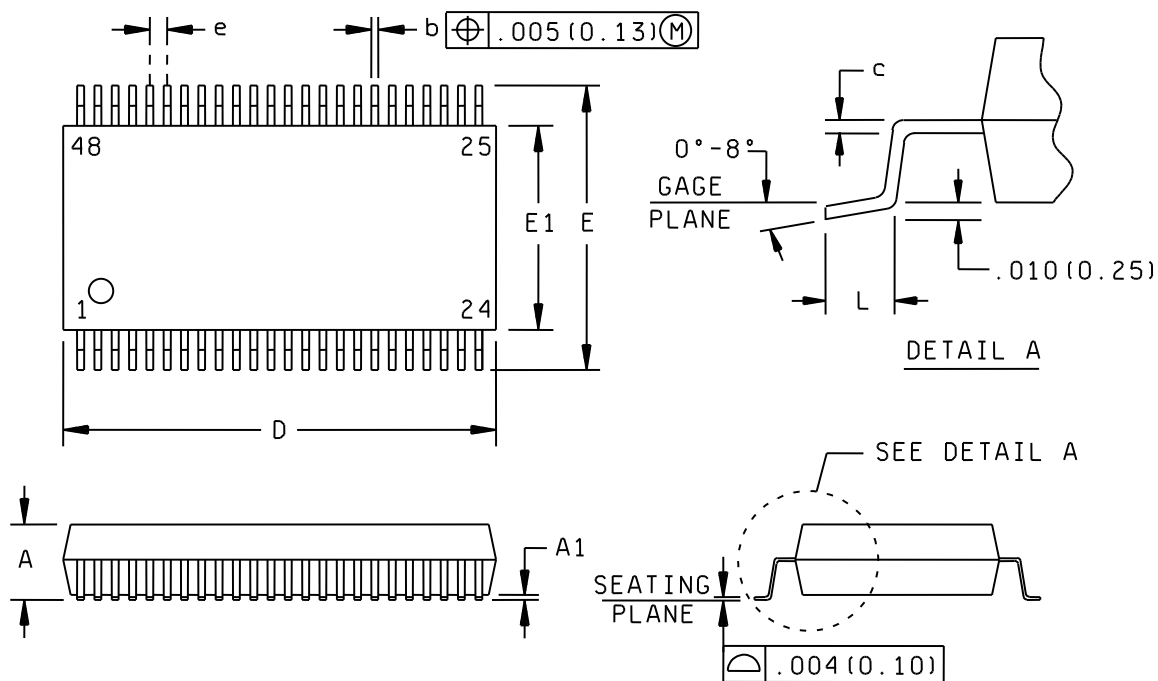

Dimensions									
Symbol	Inches		Millimeters		Symbol	Inches		Millimeters	
	Min	Max	Min	Max		Min	Max	Min	Max
A	---	.110	---	2.79	E	.291	.299	7.39	7.59
A1	.010 TYP		0.25 TYP		E1	.395	.420	10.03	10.67
b	.008	.013	0.20	0.34	e	.025 BSC		0.63 BSC	
c	.005	.010	0.13	0.25	L	.020	.040	0.51	1.02
D	.620	.630	15.75	16.00	Q	.008	---	0.20	---

NOTES:

1. All linear dimensions are in inches (millimeters).
2. This case outline is subject to change without notice.
3. Body dimensions do not include mold flash or protrusion, not to exceed 0.006 inches (0.15 mm).
4. Falls within JEDEC MO-118.

FIGURE 1. Case outline - Continued.

DLA LAND AND MARITIME COLUMBUS, OHIO	SIZE A	CAGE CODE 16236	DWG NO. V62/04709
		REV C	PAGE 8

(each 8-bit section)

Inputs		Operation
$\overline{OE}$	DIR	
L	L	B data to A bus
L	H	A data to B bus
H	X	Isolation

H = High voltage level      L = Low voltage level  
X = Immaterial

FIGURE 2. Truth table.

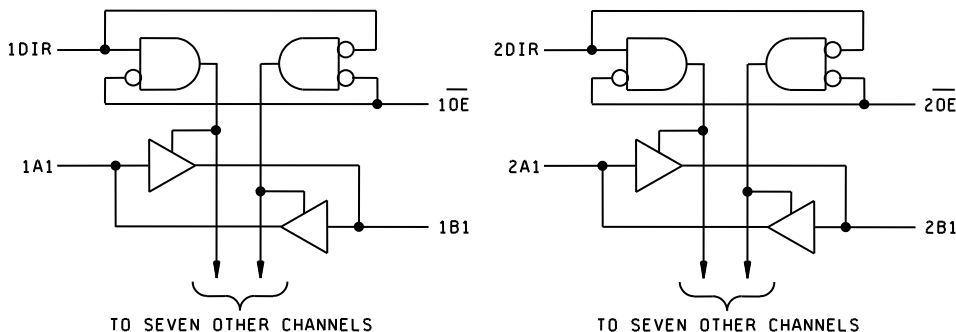
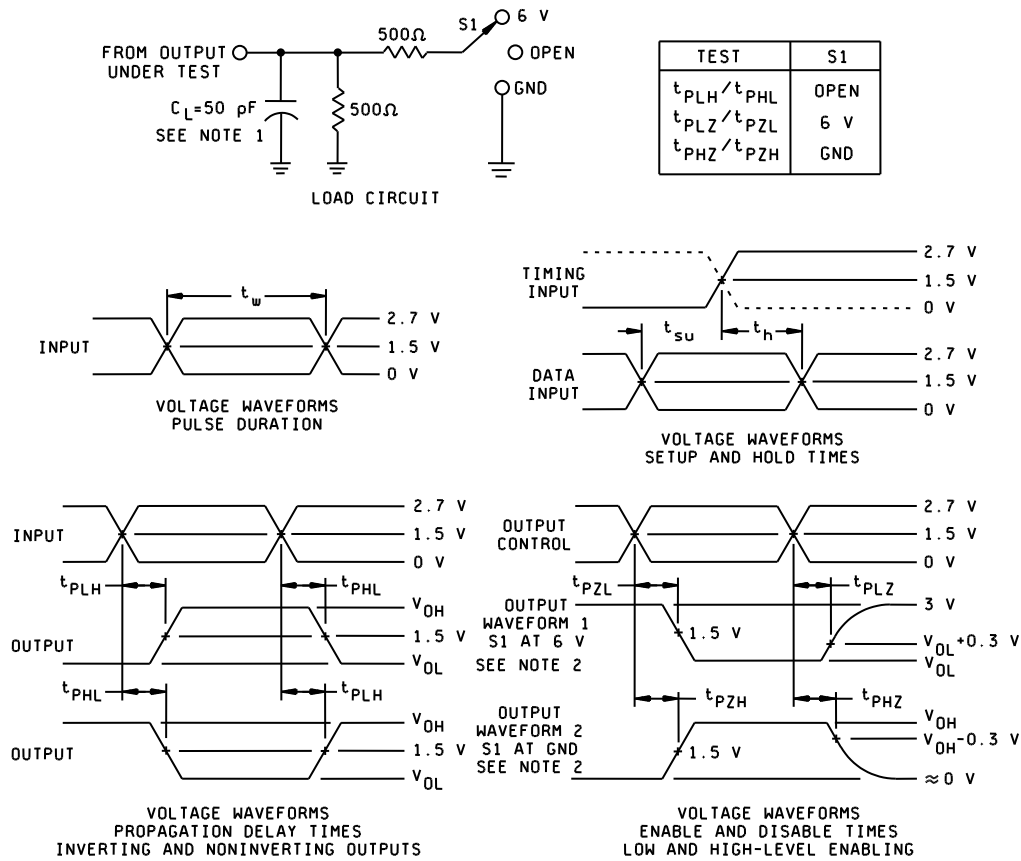

FIGURE 3. Logic diagram.

Terminal number	Terminal name	Terminal number	Terminal name	Terminal number	Terminal name	Terminal number	Terminal name
1	1DIR	13	2B1	25	$\overline{2OE}$	37	1A8
2	1B1	14	2B2	26	2A8	38	1A7
3	1B2	15	GND	27	2A7	39	GND
4	GND	16	2B3	28	GND	40	1A6
5	1B3	17	2B4	29	2A6	41	1A5
6	1B4	18	V <sub>CC</sub>	30	2A5	42	V <sub>CC</sub>
7	V <sub>CC</sub>	19	2B5	31	V <sub>CC</sub>	43	1A4
8	1B5	20	2B6	32	2A4	44	1A3
9	1B6	21	GND	33	2A3	45	GND
10	GND	22	2B7	34	GND	46	1A2
11	1B7	23	2B8	35	2A2	47	1A1
12	1B8	24	2DIR	36	2A1	48	$\overline{1OE}$

FIGURE 4. Terminal connections.

DLA LAND AND MARITIME COLUMBUS, OHIO	SIZE A	CAGE CODE 16236	DWG NO. V62/04709
		REV C	PAGE 9



**NOTES:**

1.  $C_L$  includes probe and jig capacitance.
2. Waveform 1 is for an output with internal conditions such that the output is low except when disabled by the output control. Waveform 2 is for an output with internal conditions such that the output is high except when disabled by the output control.
3. All input pulses are supplied by generators having the following characteristics:  $PRR \leq 10 \text{ MHz}$ ,  $Z_o = 50 \Omega$ ,  $t_r \leq 2.5 \text{ ns}$ , and  $t_f \leq 2.5 \text{ ns}$ .
4. The outputs are measured one at a time with one input transition per measurement.

FIGURE 5. Test circuit and timing waveforms.

DLA LAND AND MARITIME COLUMBUS, OHIO	SIZE A	CAGE CODE 16236	DWG NO. V62/04709
		REV C	PAGE 10

4. VERIFICATION

4.1 Product assurance requirements. The manufacturer is responsible for performing all inspection and test requirements as indicated in their internal documentation. Such procedures should include proper handling of electrostatic sensitive devices, classification, packaging, and labeling of moisture sensitive devices, as applicable.

5. PREPARATION FOR DELIVERY

5.1 Packaging. Preservation, packaging, labeling, and marking shall be in accordance with the manufacturer’s standard commercial practices for electrostatic discharge sensitive devices.

6. NOTES

6.1 ESDS. Devices are electrostatic discharge sensitive and are classified as ESDS class 1 minimum.

6.2 Configuration control. The data contained herein is based on the salient characteristics of the device manufacturer’s data book. The device manufacturer reserves the right to make changes without notice. This drawing will be modified as changes are provided.

6.3 Suggested source(s) of supply. Identification of the suggested source(s) of supply herein is not to be construed as a guarantee of present or continued availability as a source of supply for the item. DLA Land and Maritime maintains an online database of all current sources of supply at <https://landandmaritimeapps.dla.mil/programs/smcr/>.

Vendor item drawing administrative control number <u>1/</u>	Device manufacturer CAGE code	Vendor part number	Top side marking
V62/04709-01XE	01295	CLVTH162245IDGGREP	LH162245EP
V62/04709-02YE	01295	CLVTH162245MDLREP	LVTH162245EP

1/ The vendor item drawing establishes an administrative control number for identifying the item on the engineering documentation

CAGE code

01295

Source of supply

Texas Instruments, Inc.  
Semiconductor Group  
8505 Forest Lane  
P.O. Box 660199  
Dallas, TX 75243

<b>DLA LAND AND MARITIME COLUMBUS, OHIO</b>	<b>SIZE A</b>	<b>CAGE CODE 16236</b>	<b>DWG NO. V62/04709</b>
		REV C	PAGE 11