

REVISIONS

LTR	DESCRIPTION	DATE (YR-MO-DA)	APPROVED
A	Update boilerplate paragraphs to current requirements. - PHN	11-04-19	David J. Corbett
B	Update boilerplate to current MIL-PRF-38535 requirements. - PHN	16-07-19	Thomas M. Hess
C	Update boilerplate paragraphs to current VID description requirements. - DRH	23-01-18	Muhammad A. Akbar

**CURRENT DESIGN ACTIVITY CAGE CODE 16236
HAS CHANGED NAMES TO:
DLA LAND AND MARITIME
COLUMBUS, OHIO 43218-3990**



Prepared in accordance with ASME Y14.24

Vendor Item Drawing

Revision Status of Sheets

REV																				
SHEET																				
REV	C	C	C	C	C	C	C	C	C	C	C									
SHEET	1	2	3	4	5	6	7	8	9	10	11									

PMIC N/A Original date of drawing 04-04-21	PREPARED BY Charles F. Saffle		DLA LAND AND MARITIME COLUMBUS, OHIO 43218-3990 https://www.dla.mil/landandmaritime	
	CHECKED BY Charles F. Saffle		TITLE MICROCIRCUIT, DIGITAL, ADVANCED BIPOLAR CMOS, 3.3-V ABT 16-BIT BUFFER/DRIVER WITH 3-STATE OUTPUTS, MONOLITHIC SILICON	
	APPROVED BY Thomas M. Hess			
	SIZE A	CAGE CODE 16236	DWG NO. V62/04708	
	REV	C	PAGE 1 OF 11	

1. SCOPE

1.1 Scope. This drawing documents the general requirements of a high performance 3.3-V ABT 16-bit buffer/driver with 3-state outputs microcircuit, with an operating temperature range of -40°C to +85°C.

1.2 Vendor Item Drawing Administrative Control Number. The manufacturer's PIN is the item of identification. The vendor item drawing establishes an administrative control number for identifying the item on the engineering documentation:

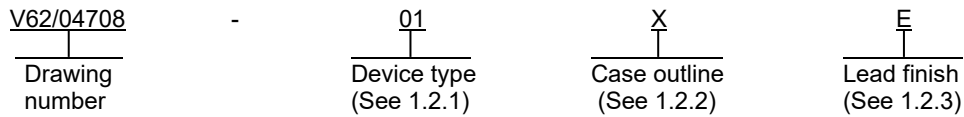

1.2.1 Device type(s).

<u>Device type</u>	<u>Generic</u>	<u>Circuit function</u>
01	SN74LVTH162244-EP	3.3-V ABT 16-bit buffer/driver with 3-state outputs

1.2.2 Case outline. The case outline are as specified herein.

<u>Outline letter</u>	<u>Number of pins</u>	<u>JEDEC PUB 95</u>	<u>Package style</u>
X	48	MO-153	Plastic small-outline

1.2.3 Lead finishes. The lead finishes are as specified below or other lead finishes as provided by the device manufacturer:

<u>Finish designator</u>	<u>Material</u>
A	Hot solder dip
B	Tin-lead plate
C	Gold plate
D	Palladium
E	Gold flash palladium
Z	Other

DLA LAND AND MARITIME COLUMBUS, OHIO	SIZE A	CAGE CODE 16236	DWG NO. V62/04708
		REV C	PAGE 2

1.3 Absolute maximum ratings. 1/

Supply voltage range (V_{CC})	-0.5 V to 4.6 V
Input voltage range (V_i)	-0.5 V to 7 V 2/
Voltage range applied to any output in the high-impedance or power-off state (V_o)	-0.5 V to 7 V 2/
Voltage range applied to any output in the high state (V_o)	-0.5 V to $V_{CC} + 0.5 V$ 2/
Current into any output in the low state (I_o)	30 mA
Current into any output in the high state (I_o)	30 mA 3/
Input clamp current (I_{IK}) ($V_i < 0$)	-50 mA
Output clamp current (I_{OK}) ($V_o < 0$)	-50 mA
Package thermal impedance (θ_{JA})	70°C/W 4/
Storage temperature range (T_{STG})	-65°C to 150°C

1.4 Recommended operating conditions. 5/ 6/

Supply voltage range (V_{CC})	2.7 V to 3.6 V
Minimum high level input voltage (V_{IH})	2.0 V
Maximum low level input voltage (V_{IL})	0.8 V
Maximum input voltage (V_i)	5.5 V
Maximum high level output current (I_{OH})	-12 mA
Maximum low level output current (I_{OL})	12 mA
Maximum input transition rise or fall rate ($\Delta t/\Delta v$) (Outputs enabled)	10 ns/V
Minimum power-up ramp rate ($\Delta t/\Delta V_{CC}$)	200 $\mu s/V$
Operating free-air temperature range (T_A)	-40°C to +85°C

-
- 1/ Stresses beyond those listed under “absolute maximum ratings” may cause permanent damage to the device. These are stress ratings only, and functional operation of the device at these or any other conditions beyond those indicated under “recommended operating conditions” is not implied. Exposure to absolute-maximum-rated conditions for extended periods may affect device reliability.
- 2/ The input and output negative-voltage ratings may be exceeded if the input and output clamp-current ratings are observed.
- 3/ This current flows only when the output is in the high state and $V_o > V_{CC}$.
- 4/ The package thermal impedance is calculated in accordance with JESD 51-7.
- 5/ All unused control inputs of the device must be held at V_{CC} or GND to ensure proper device operation.
- 6/ Use of this product beyond the manufacturers design rules or stated parameters is done at the user’s risk. The manufacturer and/or distributor maintain no responsibility or liability for product used beyond the stated limits.

DLA LAND AND MARITIME COLUMBUS, OHIO	SIZE A	CAGE CODE 16236	DWG NO. V62/04708
		REV C	PAGE 3

2. APPLICABLE DOCUMENTS

SOLID STATE TECHNOLOGY ASSOCIATION (JEDEC)

- JEDEC PUB 95 – Registered and Standard Outlines for Semiconductor Devices
- JESD 51-7 – High Effective Thermal Conductivity Test Board for Leaded Surface Mount Packages

(Copies of these documents are available online at <https://www.jedec.org>.)

3. REQUIREMENTS

3.1 Marking. Parts shall be permanently and legibly marked with the manufacturer’s part number as shown in 6.3 herein and as follows:

- A. Manufacturer’s name, CAGE code, or logo
- B. Pin 1 identifier
- C. ESDS identification (optional)

3.2 Unit container. The unit container shall be marked with the manufacturer’s part number and with items A and C (if applicable) above.

3.3 Electrical characteristics. The maximum and recommended operating conditions and electrical performance characteristics are as specified in 1.3, 1.4, and table I herein.

3.4 Design, construction, and physical dimension. The design, construction, and physical dimensions are as specified herein.

3.5 Diagrams.

3.5.1 Case outline. The case outline shall be as shown in 1.2.2 and figure 1.

3.5.2 Truth table. The truth table shall be as shown in figure 2.

3.5.3 Logic diagram. The logic diagram shall be as shown in figure 3.

3.5.4 Terminal connections. The terminal connections shall be as shown in figure 4.

3.5.5 Test circuit and timing waveforms. The test circuit and timing waveforms shall be as shown in figure 5.

DLA LAND AND MARITIME COLUMBUS, OHIO	SIZE A	CAGE CODE 16236	DWG NO. V62/04708
		REV C	PAGE 4

TABLE I. Electrical performance characteristics. 1/

Test	Symbol	Conditions	V _{CC}	Temperature, T _A	Device type	Limits		Unit
						Min	Max	
Input clamp voltage	V _{IK}	I _I = -18 mA	2.7 V	25°C, -40°C to 85°C	All		-1.2	V
High level output voltage	V _{OH}	I _{OH} = -12 mA	3 V			2		V
Low level output voltage	V _{OL}	I _{OL} = 12 mA	3 V				0.8	V
Input current	I _I	V _I = 5.5 V	0 V or 3.6 V				10	μA
		Control inputs. V _I = V _{CC} or GND	3.6 V				±1	
		Data inputs. V _I = V _{CC}					1	
		Data inputs. V _I = 0 V					-5	
Input/output power-off leakage current	I _{off}	V _I or V _O = 0 to 4.5 V	0 V			±100	μA	
Input current (hold)	I _{I(hold)}	Data inputs. V _I = 0.8 V	3 V		75	μA		
		Data inputs. V _I = 2 V			-75			
		Data inputs. V _I = 0 V to 3.6 V	3.6 V 2/		+500 -750			
3-state output current high	I _{OZH}	V _O = 3 V	3.6 V			5	μA	
3-state output current low	I _{OZL}	V _O = 0.5 V	3.6 V			-5	μA	
3-state output current power-up	I _{OZPU}	V _O = 0.5 V to 3 V \overline{OE} = don't care	0 V to 1.5 V			±100	μA	
3-state output current power-down	I _{OZPD}	V _O = 0.5 V to 3 V \overline{OE} = don't care	1.5 V to 0 V			±100	μA	

See footnotes at end of table.

DLA LAND AND MARITIME COLUMBUS, OHIO	SIZE A	CAGE CODE 16236	DWG NO. V62/04708
		REV C	PAGE 5

TABLE I. Electrical performance characteristics – Continued.

Test	Symbol	Conditions	V _{CC}	Temperature, T _A	Device type	Limits		Unit
						Min	Max	
Quiescent supply current	I _{CC}	Outputs high. V _I = V _{CC} or GND I _O = 0 A	3.6 V	25°C, -40°C to 85°C	All		0.19	mA
		Outputs low. V _I = V _{CC} or GND I _O = 0 A					5	
		Outputs disabled. V _I = V _{CC} or GND I _O = 0 A					0.19	
Quiescent supply current delta	ΔI_{CC} 3/	One input at V _{CC} – 0.6 V, Other inputs at V _{CC} or GND	3 V to 3.6 V				0.2	mA
Input capacitance	C _i	V _I = 3 V or 0 V	3.3 V	25°C		4 TYP		pF
Output capacitance	C _o	V _O = 3 V or 0 V				9 TYP		pF
Propagation delay time, A to Y	t _{PLH}	C _L = 50 pF See figure 5.	2.7 V	25°C, -40°C to 85°C			4.8	ns
			3.3 V ±0.3 V			1.4	4	
	2.7 V					4.1		
	3.3 V ±0.3 V		1.2			3.6		
Propagation delay time, output enable, \overline{OE} to Y	t _{PZH}		2.7 V				6.5	ns
	t _{PZL}		3.3 V ±0.3 V		1.2	5.1		
			2.7 V			5.8		
			3.3 V ±0.3 V		1.4	4.5		
Propagation delay time, output disable, \overline{OE} to Y	t _{PHZ}		2.7 V			5.4	ns	
			3.3 V ±0.3 V		2.2	5		
	t _{PLZ}		2.7 V			5.4		
			3.3 V ±0.3 V		2	5		
Output skew	t _{sk(o)}	C _L = 50 pF	3.3 V ±0.3 V				0.5	ns

- 1/ Testing and other quality control techniques are used to the extent deemed necessary to assure product performance over the specified temperature range. Product may not necessarily be tested across the full temperature range and all parameters may not necessarily be tested. In the absence of specific parametric testing, product performance is assured by characterization and/or design.
- 2/ This is the bus-hold maximum dynamic current. It is the minimum overdrive current required to switch the input from one state to another.
- 3/ This is the increase in supply current for each input that is at the specified TTL voltage level, rather than V_{CC} or GND.

DLA LAND AND MARITIME COLUMBUS, OHIO	SIZE A	CAGE CODE 16236	DWG NO. V62/04708
		REV C	PAGE 6

Case X

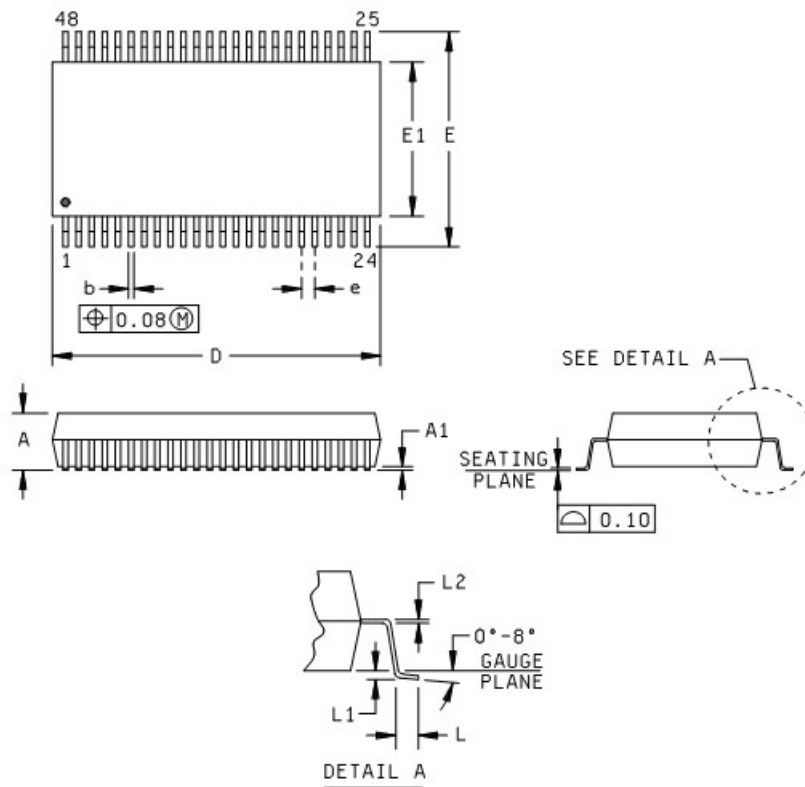

Dimensions									
Symbol	Millimeters		Inches		Symbol	Millimeters		Inches	
	Min	Max	Min	Max		Min	Max	Min	Max
A	---	1.20	---	.047	E1	6.00	6.20	.236	.244
A1	0.05	0.15	.002	.006	e	0.50 BSC		.020 BSC	
b	0.17	0.27	.007	.011	L	0.50	0.75	.020	.030
D	12.40	12.60	.488	.496	L1	0.25 TYP		.010 TYP	
E	7.90	8.30	.311	.327	L2	0.15 NOM		.006 NOM	

NOTES:

1. All linear dimensions are in millimeters (inches).
2. This case outline is subject to change without notice.
3. Body dimensions do not include mold flash or protrusion, not to exceed 0.15 millimeters (0.006 in).
4. Fall within JEDEC MO-153.

FIGURE 1. Case outline.

DLA LAND AND MARITIME COLUMBUS, OHIO	SIZE A	CAGE CODE 16236	DWG NO. V62/04708
		REV C	PAGE 7

(each 4-bit buffer)

Inputs		Output
\overline{OE}	A	Y
L	H	H
L	L	L
H	X	Z

H = High voltage level
L = Low voltage level
X = Immaterial
Z = High-impedance state

FIGURE 2. Truth table.

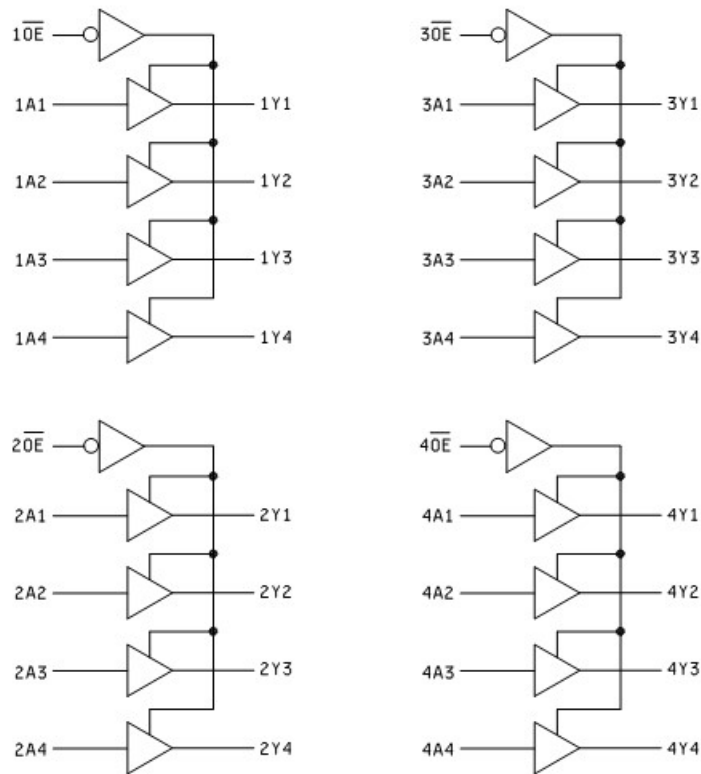

FIGURE 3. Logic diagram.

DLA LAND AND MARITIME COLUMBUS, OHIO	SIZE A	CAGE CODE 16236	DWG NO. V62/04708
		REV C	PAGE 8

Device type 01			
Case outline	X		
Terminal number	Terminal symbol	Terminal number	Terminal symbol
1	$\overline{1OE}$	25	$\overline{3OE}$
2	1Y1	26	4A4
3	1Y2	27	4A3
4	GND	28	GND
5	1Y3	29	4A2
6	1Y4	30	4A1
7	V _{CC}	31	V _{CC}
8	2Y1	32	3A4
9	2Y2	33	3A3
10	GND	34	GND
11	2Y3	35	3A2
12	2Y4	36	3A1
13	3Y1	37	2A4
14	3Y2	38	2A3
15	GND	39	GND
16	3Y3	40	2A2
17	3Y4	41	2A1
18	V _{CC}	42	V _{CC}
19	4Y1	43	1A4
20	4Y2	44	1A3
21	GND	45	GND
22	4Y3	46	1A2
23	4Y4	47	1A1
24	$\overline{4OE}$	48	$\overline{2OE}$

FIGURE 4. Terminal connections.

DLA LAND AND MARITIME COLUMBUS, OHIO	SIZE A	CAGE CODE 16236	DWG NO. V62/04708
		REV C	PAGE 9

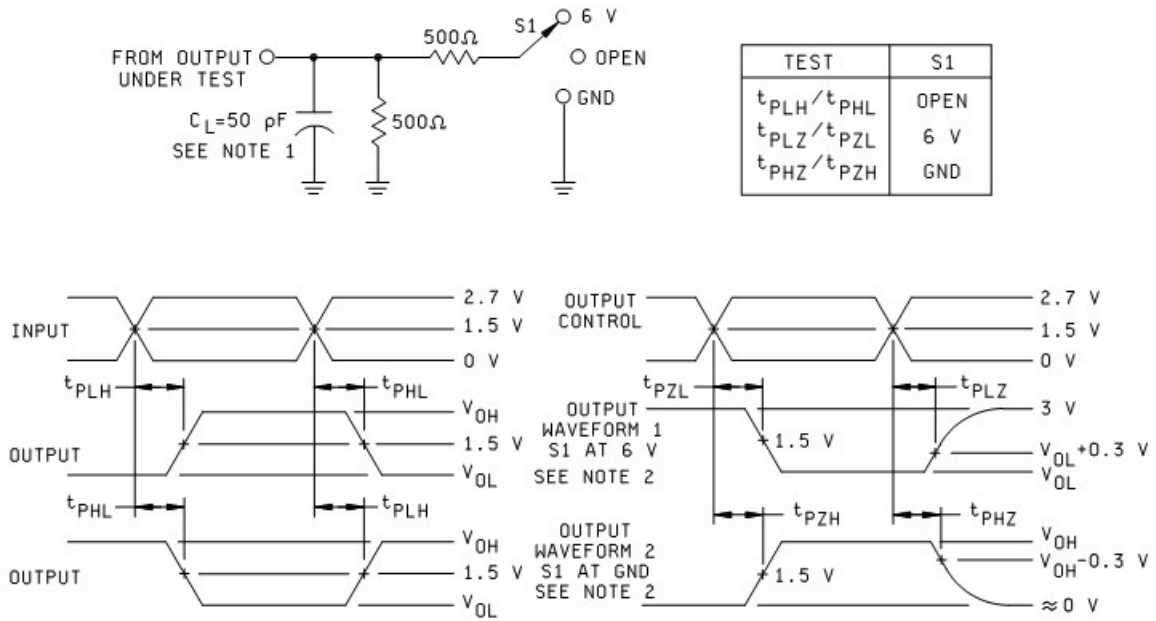

NOTES:

1. C_L includes probe and jig capacitance.
2. Waveform 1 is for an output with internal conditions such that the output is low except when disabled by the output control. Waveform 2 is for an output with internal conditions such that the output is high except when disabled by the output control.
3. All input pulses are supplied by generators having the following characteristics: $PRR \leq 10$ MHz, $Z_o = 50 \Omega$, $t_r \leq 2.5$ ns, and $t_f \leq 2.5$ ns.
4. The outputs are measured one at a time with one input transition per measurement.

FIGURE 5. Test circuit and timing waveforms.

DLA LAND AND MARITIME COLUMBUS, OHIO	SIZE A	CAGE CODE 16236	DWG NO. V62/04708
		REV C	PAGE 10

4. VERIFICATION

4.1 Product assurance requirements. The manufacturer is responsible for performing all inspection and test requirements as indicated in their internal documentation. Such procedures should include proper handling of electrostatic sensitive devices, classification, packaging, and labeling of moisture sensitive devices, as applicable.

5. PREPARATION FOR DELIVERY

5.1 Packaging. Preservation, packaging, labeling, and marking shall be in accordance with the manufacturer’s standard commercial practices for electrostatic discharge sensitive devices.

6. NOTES

6.1 ESDS. Devices are electrostatic discharge sensitive and are classified as ESDS class 1 minimum.

6.2 Configuration control. The data contained herein is based on the salient characteristics of the device manufacturer’s data book. The device manufacturer reserves the right to make changes without notice. This drawing will be modified as changes are provided.

6.3 Suggested source(s) of supply. Identification of the suggested source(s) of supply herein is not to be construed as a guarantee of present or continued availability as a source of supply for the item. DLA Land and Maritime maintains an online database of all current sources of supply at <https://landandmaritimeapps.dla.mil/programs/smcr/>.

Vendor item drawing administrative control number <u>1/</u>	Device manufacturer CAGE code	Vendor part number	Top side marking
V62/04708-01XE	01295	CLVTH162244IDGGREP	LH162244EP

1/ The vendor item drawing establishes an administrative control number for identifying the item on the engineering documentation.

CAGE code

01295

Source of supply

Texas Instruments, Inc.
Semiconductor Group
8505 Forest Lane
P.O. Box 660199
Dallas, TX 75243

DLA LAND AND MARITIME COLUMBUS, OHIO	SIZE A	CAGE CODE 16236	DWG NO. V62/04708
		REV C	PAGE 11