

REVISIONS

LTR	DESCRIPTION	DATE (YR-MO-DA)	APPROVED
A	Update boilerplate paragraphs to current requirements. - PHN	11-02-01	David J. Corbett
B	Update boilerplate to current MIL-PRF-38535 requirements. - PHN	16-06-20	Thomas M. Hess
C	Update boilerplate paragraphs to current VID description requirements. - DRH	22-11-15	Muhammad A. Akbar

**CURRENT DESIGN ACTIVITY CAGE CODE 16236
HAS CHANGED NAMES TO:
DLA LAND AND MARITIME
COLUMBUS, OHIO 43218-3990**



Prepared in accordance with ASME Y14.24

Vendor Item Drawing

Revision Status of Sheets

REV																			
SHEET																			
REV	C	C	C	C	C	C	C	C	C										
SHEET	1	2	3	4	5	6	7	8	9										

PMIC N/A Original date of drawing 04-04-12	PREPARED BY Charles F. Saffle		DLA LAND AND MARITIME COLUMBUS, OHIO 43218-3990 https://www.dla.mil/landandmaritime	
	CHECKED BY Charles F. Saffle		TITLE MICROCIRCUIT, DIGITAL, ADVANCED BIPOLAR CMOS, OCTAL BUFFER/DRIVER WITH 3-STATE OUTPUTS, MONOLITHIC SILICON	
	APPROVED BY Thomas M. Hess		DWG NO. V62/04700	
	SIZE A	CAGE CODE 16236	PAGE 1 OF 9	

1. SCOPE

1.1 Scope. This drawing documents the general requirements of a high performance octal buffer/driver with 3-state outputs microcircuit, with an operating temperature range of -40°C to +85°C.

1.2 Vendor Item Drawing Administrative Control Number. The manufacturer's PIN is the item of identification. The vendor item drawing establishes an administrative control number for identifying the item on the engineering documentation:

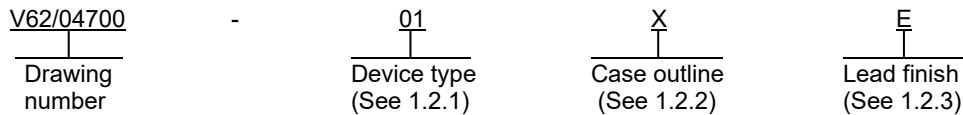

1.2.1 Device type(s).

<u>Device type</u>	<u>Generic</u>	<u>Circuit function</u>
01	SN74ABT541B-EP	Octal buffer/driver with 3-state outputs

1.2.2 Case outlines. The case outlines are as specified herein.

<u>Outline letter</u>	<u>Number of pins</u>	<u>JEDEC PUB 95</u>	<u>Package style</u>
X	20	MO-153	Plastic small-outline

1.2.3 Lead finishes. The lead finishes are as specified below or other lead finishes as provided by the device manufacturer:

<u>Finish designator</u>	<u>Material</u>
A	Hot solder dip
B	Tin-lead plate
C	Gold plate
D	Palladium
E	Gold flash palladium
Z	Other

1.3 Absolute maximum ratings. 1/

Supply voltage range (V_{CC})	-0.5 V to 7 V
Input voltage range (V_I)	-0.5 V to 7 V 2/
Voltage range applied to any output in the high or power-off state (V_O)	-0.5 V to 5.5 V
Current into any output in the low state (I_O)	128 mA
Input clamp current (I_{IK}) ($V_I < 0$)	-18 mA
Output clamp current (I_{OK}) ($V_O < 0$)	-50 mA
Package thermal impedance (θ_{JA})	128°C/W 3/
Storage temperature range (T_{STG})	-65°C to 150°C

1/ Stresses beyond those listed under "absolute maximum ratings" may cause permanent damage to the device. These are stress ratings only, and functional operation of the device at these or any other conditions beyond those indicated under "recommended operating conditions" is not implied. Exposure to absolute maximum rated conditions for extended periods may affect device reliability.

2/ The input and output negative-voltage ratings may be exceeded if the input and output clamp-current ratings are observed.

3/ The package thermal impedance is calculated in accordance with JESD 51 7.

DLA LAND AND MARITIME COLUMBUS, OHIO	SIZE A	CAGE CODE 16236	DWG NO. V62/04700
		REV C	PAGE 2

1.4 Recommended operating conditions. 4/ 5/

Supply voltage range (V_{CC})	4.5 V to 5.5 V
Minimum high level input voltage (V_{IH})	2.0 V
Maximum low level input voltage (V_{IL})	0.8 V
Maximum high level output current (I_{OH})	-32 mA
Maximum low level output current (I_{OL})	64 mA
Operating free-air temperature range (T_A)	-40°C to +85°C

2. APPLICABLE DOCUMENTS

SOLID STATE TECHNOLOGY ASSOCIATION (JEDEC)

- JEDEC PUB 95 – Registered and Standard Outlines for Semiconductor Devices
- JESD 51-7 – High Effective Thermal Conductivity Test Board for Leaded Surface Mount Packages

(Copies of these documents are available online at <https://www.jedec.org>.)

3. REQUIREMENTS

3.1 Marking. Parts shall be permanently and legibly marked with the manufacturer’s part number as shown in 6.3 herein and as follows:

- A. Manufacturer’s name, CAGE code, or logo
- B. Pin 1 identifier
- C. ESDS identification (optional)

3.2 Unit container. The unit container shall be marked with the manufacturer’s part number and with items A and C (if applicable) above.

3.3 Electrical characteristics. The maximum and recommended operating conditions and electrical performance characteristics are as specified in 1.3, 1.4, and table I herein.

3.4 Design, construction, and physical dimension. The design, construction, and physical dimensions are as specified herein.

3.5 Diagrams.

3.5.1 Case outline. The case outline shall be as shown in 1.2.2 and figure 1.

3.5.2 Truth table. The truth table shall be as shown in figure 2.

3.5.3 Logic diagram. The logic diagram shall be as shown in figure 3.

3.5.4 Terminal connections. The terminal connections shall be as shown in figure 4.

3.5.5 Test circuit and timing waveforms. The test circuit and timing waveforms shall be as shown in figure 5.

4/ All unused inputs of the device must be held at V_{CC} or GND to ensure proper device operation.
 5/ Use of this product beyond the manufacturers design rules or stated parameters is done at the user’s risk. The manufacturer and/or distributor maintain no responsibility or liability for product used beyond the stated limits.

DLA LAND AND MARITIME COLUMBUS, OHIO	SIZE A	CAGE CODE 16236	DWG NO. V62/04700
		REV C	PAGE 3

TABLE I. Electrical performance characteristics. 1/

Test	Symbol	Conditions	V _{CC}	Temperature, T _A	Device type	Limits		Unit	
						Min	Max		
Input clamp voltage	V _{IK}	I _I = -18 mA	4.5 V	25°C, -40°C to 85°C	All		-1.2	V	
High level output voltage	V _{OH}	I _{OH} = -3 mA	4.5 V			2.5		V	
		I _{OH} = -3 mA	5 V			3			
		I _{OH} = -32 mA	4.5 V			2			
Low level output voltage	V _{OL}	I _{OL} = 64 mA	4.5 V			0.55	V		
Hysteresis voltage	V _{hys}		5 V	25°C		100 TYP		mV	
Input current	I _I	V _I = V _{CC} or GND	5.5 V	25°C, -40°C to 85°C			±1	µA	
3-state output current power-up	I _{OZPU}	V _O = 0.5 V to 2.7 V OE = don't care	0 V to 2.1 V				±50	µA	
3-state output current power-down	I _{OZPD}	V _O = 0.5 V to 2.7 V OE = don't care	2.1 V to 0 V				±50	µA	
3-state output current high	I _{OZH}	V _O = 2.7 V	5.5 V				10	µA	
3-state output current low	I _{OZL}	V _O = 0.5 V	5.5 V				-10	µA	
Input/output power-off leakage current	I _{off}	V _I or V _O ≤ 4.5 V	0 V				±100	µA	
Output high leakage current	I _{CEX}	Outputs high V _O = 5.5 V	5.5 V				50	µA	
Output current	I _O <u>2/</u>	V _O = 2.5 V	5.5 V				-50	-180	µA
Quiescent supply current	I _{CC}	Outputs high. V _I = V _{CC} or GND, I _O = 0 A	5.5 V					250	µA
		Outputs low. V _I = V _{CC} or GND, I _O = 0 A						30	mA
		Outputs disabled. V _I = V _{CC} or GND, I _O = 0 A				250	µA		
Quiescent supply current delta	ΔI _{CC} <u>3/</u>	Outputs enabled. One input at 3.4 V, Other inputs at V _{CC} or GND	5.5 V	25°C, -40°C to 85°C			1.5	mA	
		Outputs disabled. One input at 3.4 V, Other inputs at V _{CC} or GND					50	µA	
		Control inputs. One input at 3.4 V, Other inputs at V _{CC} or GND					1.5	mA	

See footnotes at end of table.

DLA LAND AND MARITIME COLUMBUS, OHIO	SIZE A	CAGE CODE 16236	DWG NO. V62/04700
		REV C	PAGE 4

TABLE I. Electrical performance characteristics - Continued. 1/

Test	Symbol	Conditions	V _{CC}	Temperature, T _A	Device type	Limits		Unit
						Min	Max	
Input capacitance	C _i	V _I = 2.5 V or 0.5 V	5 V	25°C	All	3 TYP		pF
Output capacitance	C _o	V _O = 2.5 V or 0.5 V	5 V			6 TYP		pF
Propagation delay time, A to Y	t _{PLH}	C _L = 50 pF See figure 5.	5 V	25°C		1	3.2	ns
			4.5 V to 5.5 V	-40°C to 85°C		1	3.6	
	5 V		25°C	1		3.5		
	4.5 V to 5.5 V		-40°C to 85°C	1		3.9		
Propagation delay time, output enable, \overline{OE} to Y	t _{PZH}	C _L = 50 pF See figure 5.	5 V	25°C		2	4.5	ns
			4.5 V to 5.5 V	-40°C to 85°C		2	4	
	5 V		25°C	1.9		5.1		
	4.5 V to 5.5 V		-40°C to 85°C	1.9		5.9		
Propagation delay time, output disable, \overline{OE} to Y	t _{PHZ}	C _L = 50 pF See figure 5.	5 V	25°C	2.2	5.4	ns	
			4.5 V to 5.5 V	-40°C to 85°C	2.2	5.8		
	5 V		25°C	1.5	4			
	4.5 V to 5.5 V		-40°C to 85°C	1.5	4.4			
Output skew	t _{sk(o)}	C _L = 50 pF	5 V	25°C		0.5	ns	
	<u>4/</u>		4.5 V to 5.5 V	-40°C to 85°C		0.5		

1/ Testing and other quality control techniques are used to the extent deemed necessary to assure product performance over the specified temperature range. Product may not necessarily be tested across the full temperature range and all parameters may not necessarily be tested. In the absence of specific parametric testing, product performance is assured by characterization and/or design.

2/ Not more than one output should be tested at a time, and the duration of the test should not exceed one second.

3/ This is the increase in supply current for each input that is at the specified TTL voltage level, rather than V_{CC} or GND.

4/ Skew between any two outputs of the same package switching in the same direction.

DLA LAND AND MARITIME COLUMBUS, OHIO	SIZE A	CAGE CODE 16236	DWG NO. V62/04700
		REV C	PAGE 5

Case X

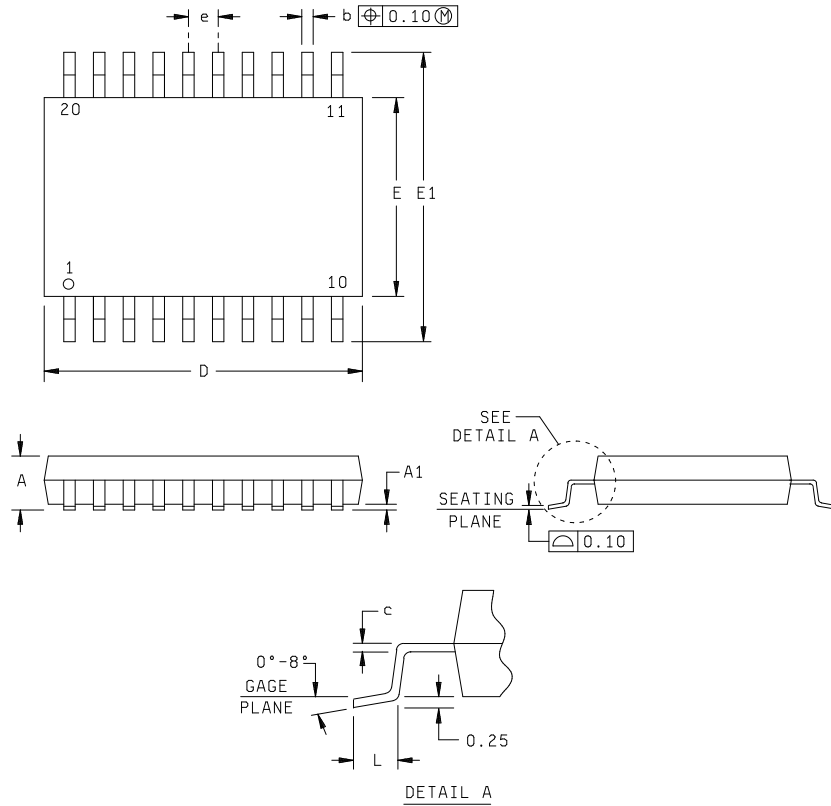

Dimensions									
Symbol	Millimeters		Inches		Symbol	Millimeters		Inches	
	Min	Max	Min	Max		Min	Max	Min	Max
A	---	1.20	---	.047	E	4.30	4.50	.169	.177
A1	0.05	0.15	.002	.006	E1	6.20	6.60	.244	.260
b	0.19	0.30	.007	.012	e	0.65 BSC		.026 BSC	
c	0.15 NOM		.006 NOM		L	0.50	0.75	.020	.030
D	6.40	6.60	.252	.260					

NOTES:

1. All linear dimensions are in millimeters (inches).
2. This case outline is subject to change without notice.
3. Body dimensions do not include mold flash or protrusion, not to exceed 0.15 millimeters (0.006 in).
4. Fall within JEDEC MO-153.

FIGURE 1. Case outline.

DLA LAND AND MARITIME COLUMBUS, OHIO	SIZE A	CAGE CODE 16236	DWG NO. V62/04700
		REV C	PAGE 6

Inputs			Output
$\overline{OE1}$	$\overline{OE2}$	A	Y
L	L	L	L
L	L	H	H
H	X	X	Z
X	H	X	Z

H = High voltage level X = Immaterial
L = Low voltage level Z = High-impedance state

FIGURE 2. Truth table.

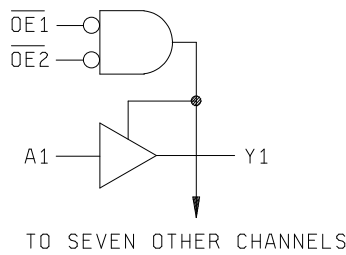
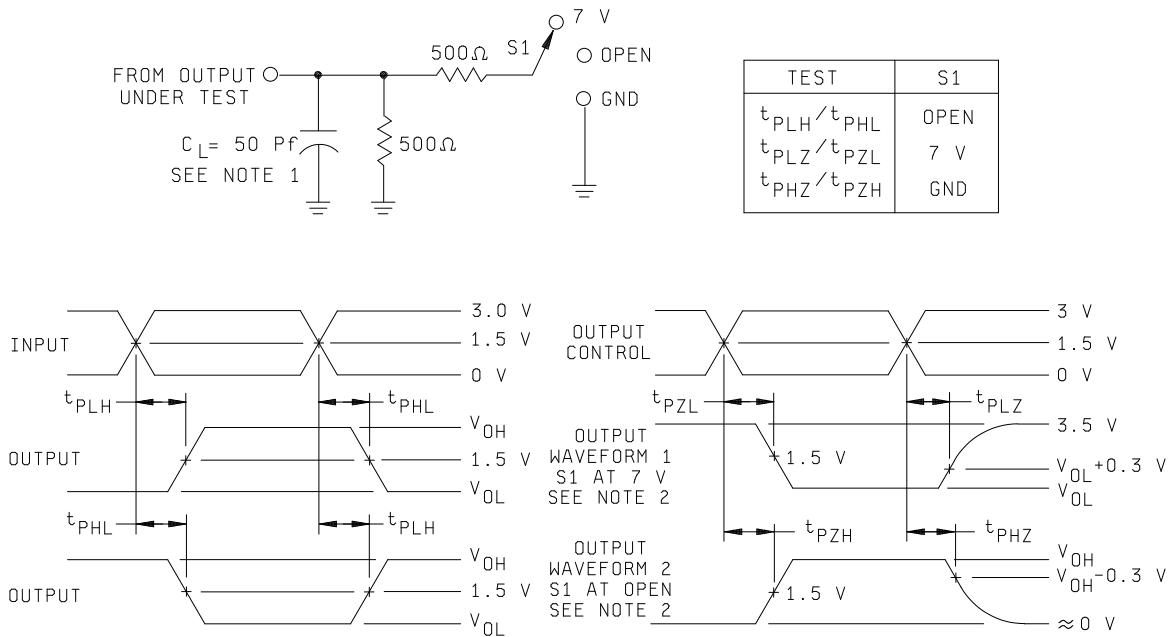

FIGURE 3. Logic diagram.

Device type 01			
Case outlines: X			
Terminal number	Terminal symbol	Terminal number	Terminal symbol
1	$\overline{OE1}$	11	Y8
2	A1	12	Y7
3	A2	13	Y6
4	A3	14	Y5
5	A4	15	Y4
6	A5	16	Y3
7	A6	17	Y2
8	A7	18	Y1
9	A8	19	$\overline{OE2}$
10	GND	20	V _{cc}

FIGURE 4. Terminal connections.

DLA LAND AND MARITIME COLUMBUS, OHIO	SIZE A	CAGE CODE 16236	DWG NO. V62/04700
		REV C	PAGE 7



NOTES:

1. C_L includes probe and jig capacitance.
2. Waveform 1 is for an output with internal conditions such that the output is low except when disabled by the output control. Waveform 2 is for an output with internal conditions such that the output is high except when disabled by the output control.
3. All input pulses are supplied by generators having the following characteristics: $PRR \leq 10 \text{ MHz}$, $Z_o = 50 \Omega$, $t_r \leq 2.5 \text{ ns}$, and $t_f \leq 2.5 \text{ ns}$.
4. The outputs are measured one at a time with one input transition per measurement.

FIGURE 5. Test circuit and timing waveforms.

DLA LAND AND MARITIME COLUMBUS, OHIO	SIZE A	CAGE CODE 16236	DWG NO. V62/04700
		REV C	PAGE 8

4. VERIFICATION

4.1 Product assurance requirements. The manufacturer is responsible for performing all inspection and test requirements as indicated in their internal documentation. Such procedures should include proper handling of electrostatic sensitive devices, classification, packaging, and labeling of moisture sensitive devices, as applicable.

5. PREPARATION FOR DELIVERY

5.1 Packaging. Preservation, packaging, labeling, and marking shall be in accordance with the manufacturer’s standard commercial practices for electrostatic discharge sensitive devices.

6. NOTES

6.1 ESDS. Devices are electrostatic discharge sensitive and are classified as ESDS class 1 minimum.

6.2 Configuration control. The data contained herein is based on the salient characteristics of the device manufacturer’s data book. The device manufacturer reserves the right to make changes without notice. This drawing will be modified as changes are provided.

6.3 Suggested source(s) of supply. Identification of the suggested source(s) of supply herein is not to be construed as a guarantee of present or continued availability as a source of supply for the item. DLA Land and Maritime maintains an online database of all current sources of supply at <https://landandmaritimeapps.dla.mil/programs/smcr/>.

Vendor item drawing administrative control number <u>1/</u>	Device manufacturer CAGE code	Vendor part number	Top side marking
V62/04700-01XE	01295	SN74ABT541BIPWREP	ABT541EP

1/ The vendor item drawing establishes an administrative control number for identifying the item on the engineering documentation.

CAGE code

01295

Source of supply

Texas Instruments, Inc.
Semiconductor Group
8505 Forest Lane
P.O. Box 660199
Dallas, TX 75243

DLA LAND AND MARITIME COLUMBUS, OHIO	SIZE A	CAGE CODE 16236	DWG NO. V62/04700
		REV C	PAGE 9