

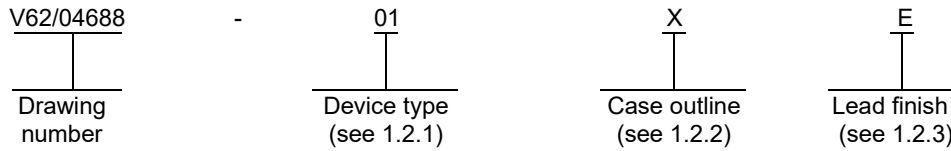

1. SCOPE

1.1 Scope. This drawing documents the general requirements of a high performance triple 3-input positive NAND gate microcircuit, with an operating temperature range of -40°C to +125°C.

1.2 Vendor Item Drawing Administrative Control Number. The manufacturer's PIN is the item of identification. The vendor item drawing establishes an administrative control number for identifying the item on the engineering documentation:



1.2.1 Device type(s).

<u>Device type</u>	<u>Generic</u>	<u>Circuit function</u>
01	SN74HC10-EP	Triple 3-input NAND gate

1.2.2 Case outline(s). The case outlines are as specified herein.

<u>Outline letter</u>	<u>Number of pins</u>	<u>JEDEC PUB 95</u>	<u>Package style</u>
X	14	JEDEC MS-012	Plastic small outline package
Y	14	JEDEC MO-153	Plastic small outline package

1.2.3 Lead finishes. The lead finishes are as specified below or other lead finishes as provided by the device manufacturer:

<u>Finish designator</u>	<u>Material</u>
A	Hot solder dip
B	Tin-lead plate
C	Gold plate
D	Palladium
E	Gold flash palladium
Z	Other

1.3 Absolute maximum ratings. 1/

Supply voltage range, (V <sub>CC</sub> ) .....	-0.5 V to +7.0 V
Input clamp current, (I <sub>IK</sub> ) (V <sub>I</sub> < 0 or V <sub>I</sub> > V <sub>CC</sub> ) .....	±20 mA 2/
Output clamp current, (I <sub>OK</sub> ) (V <sub>O</sub> < 0 or V <sub>O</sub> > V <sub>CC</sub> ) .....	±20 mA 2/
Continuous output current, (I <sub>O</sub> ) (V <sub>O</sub> = 0 to V <sub>CC</sub> ) .....	±25 mA
Continuous current through V <sub>CC</sub> or GND .....	±50 mA
Package thermal impedance (θ <sub>JA</sub> ): 3/	
X package .....	86°C/W
Y package .....	113°C/W
Storage temperature range, (T <sub>STG</sub> ).....	-65°C to +150°C

1/ Stresses beyond those listed under "absolute maximum rating" may cause permanent damage to the device. These are stress ratings only, and functional operation of the device at these or any other conditions beyond those indicated under "recommended operating conditions" is not implied. Exposure to absolute-maximum-rated conditions for extended periods may affect device reliability.

2/ The input and output voltage ratings may exceeded if the input and output current ratings are observed.

3/ The package thermal impedance is calculated in accordance with JESD 51-7.

<b>DLA LAND AND MARITIME COLUMBUS, OHIO</b>	<b>SIZE A</b>	<b>CAGE CODE 16236</b>	<b>DWG NO. V62/04688</b>
		REV      C	PAGE 2

1.4 Recommended operating conditions. 4/ 5/

Supply voltage, (V <sub>CC</sub> ) .....	+2.0 V to +6.0 V
Minimum high level input voltage, (V <sub>IH</sub> ):	
V <sub>CC</sub> = 2.0 V .....	+1.5 V
V <sub>CC</sub> = 4.5 V .....	+3.15 V
V <sub>CC</sub> = 6.0 V .....	+4.2 V
Maximum low level input voltage, (V <sub>IL</sub> ):	
V <sub>CC</sub> = 2.0 V .....	+0.5 V
V <sub>CC</sub> = 4.5 V .....	+1.35 V
V <sub>CC</sub> = 6.0 V .....	+1.8 V
Input voltage, (V <sub>I</sub> ) .....	0.0 V to V <sub>CC</sub>
Output voltage, (V <sub>O</sub> ) .....	0.0 V to V <sub>CC</sub>
Maximum input transition rise/fall rate (Δt/Δv)	
V <sub>CC</sub> = 2.0 V .....	1000 ns
V <sub>CC</sub> = 4.5 V .....	500 ns
V <sub>CC</sub> = 6.0 V .....	400 ns
Operating free air temperature, (T <sub>A</sub> ) .....	-40°C to +85°C

---

4/ All unused inputs of the device must be held at V<sub>CC</sub> or GND to ensure proper device operation.  
5/ Use of this product beyond the manufacturers design rules or stated parameters is done at the user's risk. The manufacturer and/or distributor maintain no responsibility or liability for product used beyond the stated limits.

<b>DLA LAND AND MARITIME COLUMBUS, OHIO</b>	<b>SIZE A</b>	<b>CAGE CODE 16236</b>	<b>DWG NO. V62/04688</b>
		REV      C	PAGE 3

2. APPLICABLE DOCUMENTS

JEDEC – SOLID STATE TECHNOLOGY ASSOCIATION (JEDEC)

- JEP95 – Registered and Standard Outlines for Semiconductor Devices
- JESD51-7 – High Effective Thermal Conductivity Test Board for Leaded Surface Mount Packages

(Copies of these documents are available online at <https://www.jedec.org> ).

3. REQUIREMENTS

3.1 Marking. Parts shall be permanently and legibly marked with the manufacturer’s part number as shown in 6.3 herein and as follows:

- A. Manufacturer’s name, CAGE code, or logo
- B. Pin 1 identifier
- C. ESDS identification (optional)

3.2 Unit container. The unit container shall be marked with the manufacturer’s part number and with items A and C (if applicable) above.

3.3 Electrical characteristics. The maximum and recommended operating conditions and electrical performance characteristics are as specified in 1.3, 1.4, and table I herein.

3.4 Design, construction, and physical dimension. The design, construction, and physical dimensions are as specified herein.

3.5 Diagrams.

3.5.1 Case outline(s). The case outline(s) shall be as shown in 1.2.2 and figure 1.

3.5.2 Terminal connections. The terminal connections shall be as shown in figure 2.

3.5.3 Logic diagram. The logic diagram shall be as shown in figure 3.

3.5.4 Function table. The function table shall be as shown in figure 4.

3.5.5 Load circuit and timing waveforms. The load circuit and timing waveforms shall be as specified in figure 5.

<b>DLA LAND AND MARITIME COLUMBUS, OHIO</b>	<b>SIZE A</b>	<b>CAGE CODE 16236</b>		<b>DWG NO. V62/04688</b>
		REV	C	PAGE 4

TABLE I. Electrical performance characteristics. 1/

Test	Symbol	Conditions	V <sub>CC</sub>	T <sub>A</sub> = 25°C		-40°C ≤ T <sub>A</sub> ≤ +125°C		Unit	
				Min	Max	Min	Max		
High level output voltage	V <sub>OH</sub>	V <sub>I</sub> = V <sub>IH</sub> or V <sub>IL</sub>	I <sub>OH</sub> = -20 μA	2.0 V	1.9		1.9	V	
				4.5 V	4.4		4.4		
				6.0 V	5.9		5.9		
			I <sub>OH</sub> = -4.0 mA	4.5 V	3.98		3.7		
			I <sub>OH</sub> = -5.2 mA	6.0 V	5.48		5.2		
Low level output voltage	V <sub>OL</sub>	V <sub>I</sub> = V <sub>IH</sub> or V <sub>IL</sub>	I <sub>OL</sub> = 20 μA	2.0 V		0.1			
				4.5 V		0.1			0.1
				6.0 V		0.1			0.1
			I <sub>OL</sub> = 4.0 mA	4.5 V		0.26			0.4
			I <sub>OL</sub> = 5.2 mA	6.0 V		0.26			0.4
Input current	I <sub>I</sub>	V <sub>I</sub> = V <sub>CC</sub> or 0	6.0 V		±100		±1000	nA	
Quiescent supply current	I <sub>CC</sub>	V <sub>I</sub> = V <sub>CC</sub> or 0	6.0 V		2		40	μA	
Input capacitance	C <sub>I</sub>		2.0 V to 6.0 V		10		10	pF	
<b>Switching characteristics</b>									
From input A , B or C to output Y	t <sub>Pd</sub>		2.0 V		95		145	ns	
			4.5 V		19		29		
			6.0 V		16		25		
Transition time from any input to output Y	t <sub>t</sub>		2.0 V		75		110		
			4.5 V		15		22		
			6.0 V		13		19		
<b>Operating characteristics</b>									
Power dissipation capacitance per gate	C <sub>Pd</sub>	No load			25 Typ			pF	

1/ Testing and other quality control techniques are used to the extent deemed necessary to assure product performance over the specified temperature range. Product may not necessarily be tested across the full temperature range and all parameters may not necessarily be tested. In the absence of specific parametric testing, product performance is assured by characterization and/or design.

DLA LAND AND MARITIME COLUMBUS, OHIO	SIZE A	CAGE CODE 16236	DWG NO. V62/04688
		REV C	PAGE 5

Case X

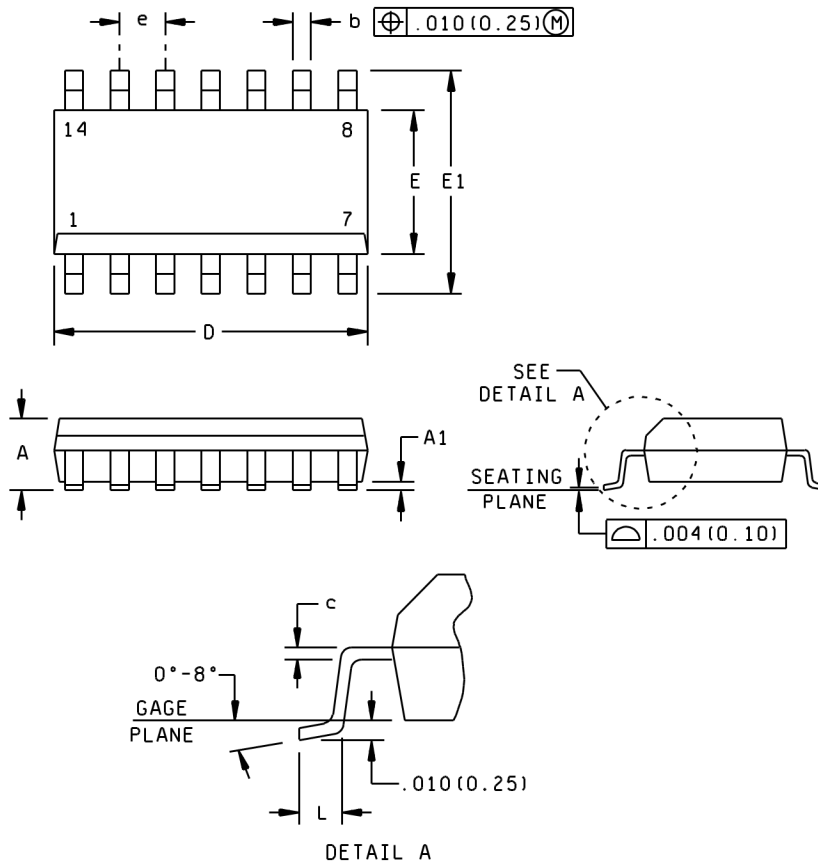

Dimensions									
Symbol	Inches		Millimeters		Symbol	Inches		Millimeters	
	Min	Max	Min	Max		Min	Max	Min	Max
A	---	0.069	---	1.75	E	0.150	0.157	3.81	4.00
A1	0.004	0.010	0.10	0.25	E1	0.228	0.244	5.80	6.20
b	0.014	0.020	0.35	0.51	e	0.050	BSC	1.27	BSC
c	0.008	NOM	0.20	NOM	L	0.016	0.044	0.40	1.12
D	0.337	0.344	8.55	8.75					

Notes:

1. All linear dimensions are in inches (millimeters).
2. This drawing is subject to change without notice.
3. Body dimensions do not include mold flash or protrusion, not to exceed 0.006 (0.15).
4. Fall within JEDEC MS-012

FIGURE 1. Case outlines.

DLA LAND AND MARITIME COLUMBUS, OHIO	SIZE A	CAGE CODE 16236	DWG NO. V62/04688
		REV C	PAGE 6

Case Y

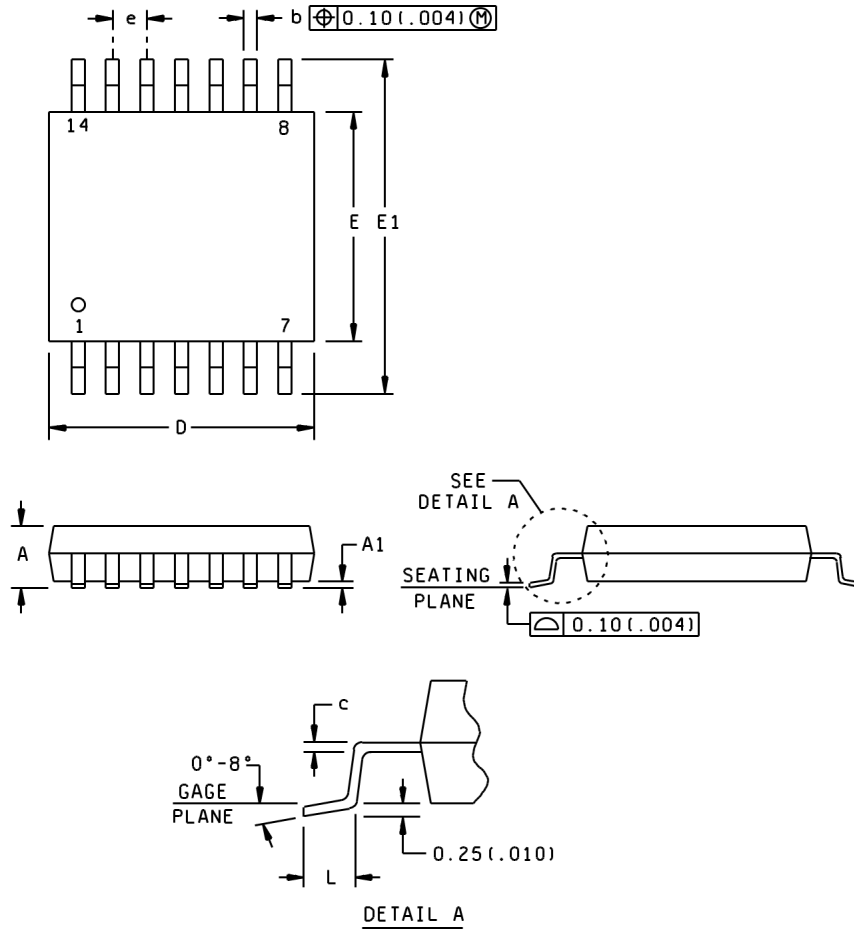

Dimensions									
Symbol	Inches		Millimeters		Symbol	Inches		Millimeters	
	Min	Max	Min	Max		Min	Max	Min	Max
A	---	0.047	---	1.20	E	0.169	0.177	4.30	4.50
A1	0.002	0.006	0.05	0.15	E1	0.244	0.260	6.20	6.60
b	0.007	0.012	0.19	0.30	e	0.026	BSC	0.65	BSC
c	0.006	NOM	0.15	NOM	L	0.020	0.030	0.50	0.75
D	0.193	0.200	4.90	5.10					

Notes:

1. All linear dimensions are in inches (millimeters).
2. This drawing is subject to change without notice.
3. Body dimensions do not include mold flash or protrusion, not to exceed 0.006 (0.15).
4. Fall within JEDEC MO-153

FIGURE 1. Case outlines - Continued.

DLA LAND AND MARITIME COLUMBUS, OHIO	SIZE A	CAGE CODE 16236	DWG NO. V62/04688
		REV C	PAGE 7

Case X or Y

Pin No.	Signal name	Pin No.	Signal name
1	1A	8	3Y
2	1B	9	3A
3	2A	10	3B
4	2B	11	3C
5	2C	12	1Y
6	2Y	13	1C
7	GND	14	V <sub>cc</sub>

FIGURE 2. Terminal connections.

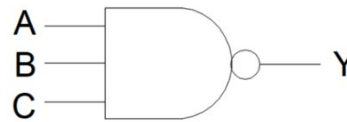

FIGURE 3. Logic diagram.

Inputs			Output
A	B	C	Y
H	H	H	L
L	X	X	H
X	L	X	H
X	X	L	H

FIGURE 4. Function Table

<b>DLA LAND AND MARITIME COLUMBUS, OHIO</b>	<b>SIZE A</b>	<b>CAGE CODE 16236</b>	<b>DWG NO. V62/04688</b>
		REV      C	PAGE 8



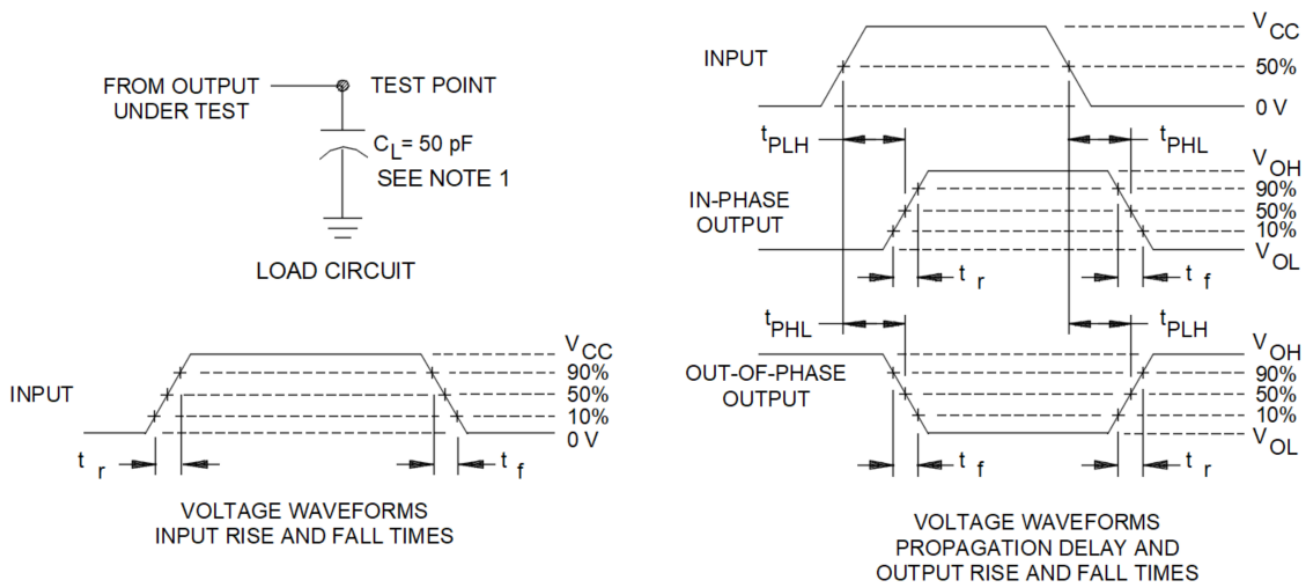

Notes:

1.  $C_L$  includes probe and test fixture capacitance.
2. Phase relationships between waveforms were chosen arbitrarily. All input pulses are supplied by generators having the following characteristics:  $PRR \leq 1 \text{ MHz}$ ,  $Z_O = 50 \Omega$ ,  $t_r = 6 \text{ ns}$ ,  $t_f = 6 \text{ ns}$ .
3. The outputs are measured one at a time with one input transition per measurement.
4.  $t_{PLH}$  and  $t_{PHL}$  are the same  $t_{pd}$ .

FIGURE 5. Load circuit and timing waveforms.

DLA LAND AND MARITIME COLUMBUS, OHIO	SIZE A	CAGE CODE 16236	DWG NO. V62/04688
		REV      C	PAGE 9

4. VERIFICATION

4.1 Product assurance requirements. The manufacturer is responsible for performing all inspection and test requirements as indicated in their internal documentation. Such procedures should include proper handling of electrostatic sensitive devices, classification, packaging, and labeling of moisture sensitive devices, as applicable.

5. PREPARATION FOR DELIVERY

5.1 Packaging. Preservation, packaging, labeling, and marking shall be in accordance with the manufacturer's standard commercial practices for electrostatic discharge sensitive devices.

6. NOTES

6.1 ESDS. Devices are electrostatic discharge sensitive and are classified as ESDS class 1 minimum.

6.2 Configuration control. The data contained herein is based on the salient characteristics of the device manufacturer's data book. The device manufacturer reserves the right to make changes without notice. This drawing will be modified as changes are provided.

6.3 Suggested source(s) of supply. Identification of the suggested source(s) of supply herein is not to be construed as a guarantee of present or continued availability as a source of supply for the item. DLA Land and Maritime maintains an online database of all current sources of supply at <https://landandmaritimeapps.dla.mil/programs/smcr/>.

Vendor item drawing administrative control number <u>1/</u>	Device manufacturer CAGE code	Vendor part number	Top side marking
V62/04688-01XE	01295	SN74HC10QDREP	SHC10EP
V62/04688-01YE	01295	SN74HC10QPWREP	SHC10EP

1/ The vendor item drawing establishes an administrative control number for identifying the item on the engineering documentation.

CAGE code

01295

Source of supply

Texas Instruments, Inc.  
Semiconductor Group  
8505 Forest Lane  
P.O. Box 660199  
Dallas, TX 75243

<b>DLA LAND AND MARITIME COLUMBUS, OHIO</b>	<b>SIZE A</b>	<b>CAGE CODE 16236</b>	<b>DWG NO. V62/04688</b>
		REV      C	PAGE 10