

REVISIONS

LTR	DESCRIPTION	DATE (YR-MO-DA)	APPROVED
A	Update boilerplate paragraphs to current requirements. - PHN	10-04-19	Thomas M. Hess
B	Update boilerplate to current MIL-PRF-38535 requirements. - PHN	16-01-25	Thomas M. Hess
C	Update boilerplate paragraphs to current VID description requirements. - PHN	22-09-21	Muhammad A. Akbar



**CURRENT DESIGN ACTIVITY CAGE CODE 16236
HAS CHANGED NAMES TO:
DLA LAND AND MARITIME
COLUMBUS, OHIO 43218-3990**

Prepared in accordance with ASME Y14.24

Vendor Item Drawing

Revision Status of Sheets

REV																					
SHEET																					
REV																					
SHEET																					
REV	C	C	C	C	C	C	C	C	C	C	C										
SHEET	1	2	3	4	5	6	7	8	9	10	11										

PMIC N/A Original date of drawing YY MM DD 04-03-15	PREPARED BY Charles F. Saffle		DEFENSE SUPPLY CENTER, COLUMBUS COLUMBUS, OHIO 43218-3990 https://www.dla.mil/LandandMaritime		
	CHECKED BY Charles F. Saffle		TITLE MICROCIRCUIT, DIGITAL, LOW VOLTAGE CMOS, OCTAL EDGE-TRIGGERED D-TYPE FLIP-FLOP WITH 3-STATE OUTPUTS, MONOLITHIC SILICON		
	APPROVED BY Thomas M. Hess				
	SIZE A	CAGE CODE 16236	DWG NO. V62/04663		
	REV C		PAGE 1 OF 11		

1. SCOPE

1.1 Scope. This drawing documents the general requirements of a high performance octal edge-triggered D-type flip-flop with 3-state outputs microcircuit, with an operating temperature range of -40°C to +125°C.

1.2 Vendor Item Drawing Administrative Control Number. The manufacturer's PIN is the item of identification. The vendor item drawing establishes an administrative control number for identifying the item on the engineering documentation:

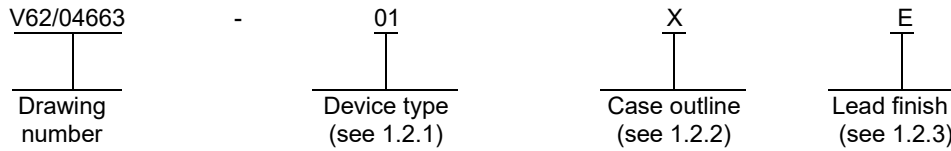

1.2.1 Device type(s).

<u>Device type</u>	<u>Generic</u>	<u>Circuit function</u>
01	SN74LVC374A-EP	Octal edge-triggered D-type flip-flop with 3-state outputs

1.2.2 Case outlines. The case outlines are as specified herein.

<u>Outline letter</u>	<u>Number of pins</u>	<u>JEDEC PUB 95</u>	<u>Package style</u>
X	20	MS-013	Plastic small-outline
Y	20	MO-153	Plastic small-outline

1.2.3 Lead finishes. The lead finishes are as specified below or other lead finishes as provided by the device manufacturer:

<u>Finish designator</u>	<u>Material</u>
A	Hot solder dip
B	Tin-lead plate
C	Gold plate
D	Palladium
E	Gold flash palladium
F	Tin-lead alloy
Z	Other

DLA LAND AND MARITIME COLUMBUS, OHIO	SIZE A	CAGE CODE 16236	DWG NO. V62/04663
		REV C	PAGE 2

1.3 Absolute maximum ratings. 1/

Supply voltage range (V_{CC})	-0.5 V to 6.5 V
Input voltage range (V_i).....	-0.5 V to 6.5 V 2/
Voltage range applied to any output in the high-impedance or power-off state (V_o).....	-0.5 V to 6.5 V 2/
Voltage range applied to any output in the high or low state (V_o).....	-0.5 V to $V_{CC} + 0.5 V$ 2/ 3/
Input clamp current (I_{IK}) ($V_i < 0$)	-50 mA
Output clamp current (I_{OK}) ($V_o < 0$)	-50 mA
Continuous output current (I_o).....	± 50 mA
Continuous current through V_{CC} or GND.....	± 100 mA
Package thermal impedance (θ_{JA}): 4/	
X package	58°C/W
Y package	83°C/W
Storage temperature range (T_{STG}).....	-65°C to 150°C 5/

1.4 Recommended operating conditions. 6/ 7/

Supply voltage range (V_{CC}):	
Operating	2.0 V to 3.6 V
Data retention only	1.5 V minimum
Minimum high level input voltage (V_{IH}) ($V_{CC} = 2.7 V$ to 3.6 V)	2.0 V
Maximum low level input voltage (V_{IL}) ($V_{CC} = 2.7 V$ to 3.6 V).....	0.8 V
Input voltage range (V_i).....	0.0 V to 5.5 V
Output voltage range (V_o):	
High or low state.....	0.0 V to V_{CC}
3-state	0.0 V to 5.5 V
Maximum high level output current (I_{OH}):	
$V_{CC} = 2.7 V$	-12 mA
$V_{CC} = 3.0 V$	-24 mA
Maximum low level output current (I_{OL}):	
$V_{CC} = 2.7 V$	12 mA
$V_{CC} = 3.0 V$	24 mA
Maximum input transition rise or fall rate ($\Delta t/\Delta v$).....	10 ns/V
Operating free-air temperature range (T_A)	-40°C to +125°C

- 1/ Stresses beyond those listed under “absolute maximum ratings” may cause permanent damage to the device. These are stress ratings only, and functional operation of the device at these or any other conditions beyond those indicated under “recommended operating conditions” is not implied. Exposure to absolute-maximum-rated conditions for extended periods may affect device reliability.
- 2/ The input negative-voltage and output voltage ratings may be exceeded if the input and output current ratings are observed.
- 3/ The value of V_{CC} is provided in the recommended operating conditions table.
- 4/ The package thermal impedance is calculated in accordance with JESD 51-7.
- 5/ Long-term high-temperature storage and/or extended use at maximum recommended operating conditions may result in a reduction of overall device life.
- 6/ All unused inputs of the device must be held at V_{CC} or GND to ensure proper device operation.
- 7/ Use of this product beyond the manufacturers design rules or stated parameters is done at the user’s risk. The manufacturer and/or distributor maintain no responsibility or liability for product used beyond the stated limits

DLA LAND AND MARITIME COLUMBUS, OHIO	SIZE A	CAGE CODE 16236	DWG NO. V62/04663
		REV C	PAGE 3

2. APPLICABLE DOCUMENTS

JEDEC – SOLID STATE TECHNOLOGY ASSOCIATION (JEDEC)

- JEP95 - Registered and Standard Outlines for Semiconductor Devices
- JESD51-7 - High Effective Thermal Conductivity Test Board for Leaded Surface Mount Packages

(Copies of these documents are available online at <https://www.jedec.org>).

3. REQUIREMENTS

3.1 Marking. Parts shall be permanently and legibly marked with the manufacturer’s part number as shown in 6.3 herein and as follows:

- A. Manufacturer’s name, CAGE code, or logo
- B. Pin 1 identifier
- C. ESDS identification (optional)

3.2 Unit container. The unit container shall be marked with the manufacturer’s part number and with items A and C (if applicable) above.

3.3 Electrical characteristics. The maximum and recommended operating conditions and electrical performance characteristics are as specified in 1.3, 1.4, and table I herein.

3.4 Design, construction, and physical dimension. The design, construction, and physical dimensions are as specified herein.

3.5 Diagrams.

3.5.1 Case outlines. The case outlines shall be as shown in 1.2.2 and figure 1.

3.5.2 Truth table. The truth table shall be as shown in figure 2.

3.5.3 Logic diagram. The logic diagram shall be as shown in figure 3.

3.5.4 Terminal connections. The terminal connections shall be as shown in figure 4.

3.5.5 Test circuit and timing waveforms. The test circuit and timing waveforms shall be as shown in figure 5.

DLA LAND AND MARITIME COLUMBUS, OHIO	SIZE A	CAGE CODE 16236		DWG NO. V62/04663
		REV	C	PAGE 4

TABLE I. Electrical performance characteristics. 1/

Test	Symbol	Conditions Device type: All	V _{CC}	Temperature, T _A	Limits		Unit
					Min	Max	
High level output voltage	V _{OH}	I _{OH} = -100 μA	2.7 V to 3.6 V	25°C, -40°C to 125°C	V _{CC} - 0.2		V
		I _{OH} = -12 mA	2.7 V		2.2		
		I _{OH} = -24 mA	3.0 V		2.4		
Low level output voltage	V _{OL}	I _{OL} = 100 μA	2.7 V to 3.6 V			0.2	V
		I _{OL} = 12 mA	2.7 V			0.4	
		I _{OL} = 24 mA	3.0 V			0.55	
Input current	I _I	V _I = 0 to 5.5 V	3.6 V			±5	μA
Three-state output leakage current	I _{OZ}	V _O = 0 to 5.5 V	3.6 V			±15	μA
Quiescent supply current	I _{CC}	V _I = V _{CC} or GND I _O = 0 A	3.6 V			10	μA
		3.6 V ≤ V _I ≤ 5.5 V 2/ I _O = 0 A				10	
Quiescent supply current delta	ΔI _{CC}	One input at V _{CC} - 0.6 V, Other inputs at V _{CC} or GND	2.7 V to 3.6 V			500	μA
Input capacitance	C _i	V _I = V _{CC} or GND	3.3 V	25°C	4 TYP		pF
				-40°C to 125°C		12	
Output capacitance	C _O	V _O = V _{CC} or GND	3.3 V	25°C	5.5 TYP		pF
				-40°C to 125°C		12	
Power dissipation capacitance per latch	C _{pd}	Outputs enabled f = 10 MHz	3.3 V	25°C	54.5 TYP		pF
		Outputs disabled f = 10 MHz	3.3 V		13.5 TYP		

See footnotes at end of table.

DLA LAND AND MARITIME COLUMBUS, OHIO	SIZE A	CAGE CODE 16236	DWG NO. V62/04663
		REV C	PAGE 5

TABLE I. Electrical performance characteristics - Continued. 1/

Test	Symbol	Conditions Device type: All	V _{CC}	Temperature, T _A	Limits		Unit
					Min	Max	
Maximum clock frequency	f _{max}		2.7 V	25°C, -40°C to 125°C	80		MHz
			3.3 V ±0.3 V		100		
Propagation delay time, CLK to Q	t _{pd}	See figure 5.	2.7 V			9.5	ns
			3.3 V ±0.3 V		1	8.5	
Propagation delay time, output enable, OE to Q	t _{en}		2.7 V			9.5	ns
			3.3 V ±0.3 V		1	8.5	
Propagation delay time, output disable, \overline{OE} to Q	t _{dis}		2.7 V			8	ns
			3.3 V ±0.3 V		1	7	
Clock frequency	f _{clock}		2.7 V			80	MHz
			3.3 V ±0.3 V			100	
Pulse duration, CLK high or low	t _w	See figure 5.	2.7 V		3.3		ns
			3.3 V ±0.3 V		3.3		
Setup time, data before CLK↑	t _{su}		2.7 V		2		ns
			3.3 V ±0.3 V		2		
Hold time, data after CLK↑	t _h		2.7 V		1.5		ns
			3.3 V ±0.3 V		1.5		

- 1/ Testing and other quality control techniques are used to the extent deemed necessary to assure product performance over the specified temperature range. Product may not necessarily be tested across the full temperature range and all parameters may not necessarily be tested. In the absence of specific parametric testing, product performance is assured by characterization and/or design.
- 2/ This applies in the disabled state only.

DLA LAND AND MARITIME COLUMBUS, OHIO	SIZE A	CAGE CODE 16236	DWG NO. V62/04663
		REV C	PAGE 6

Case X

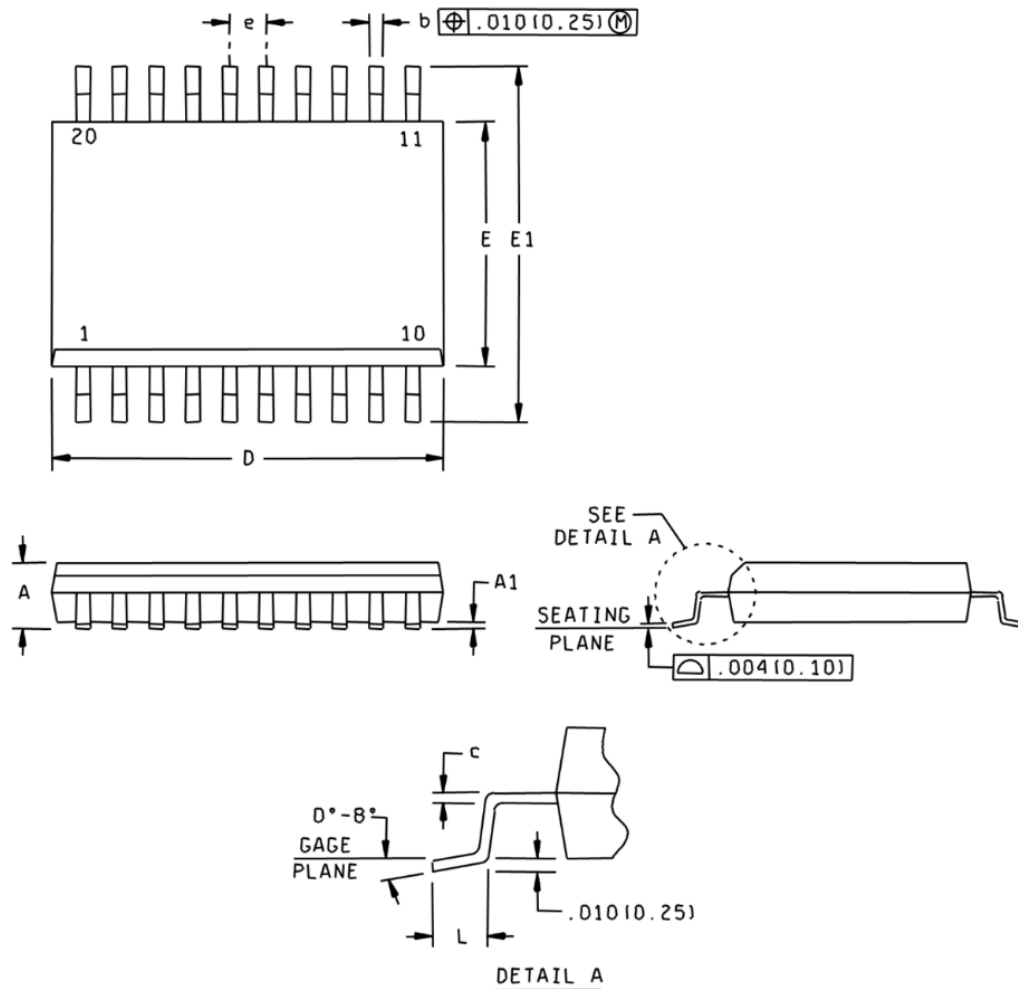

Dimensions									
Symbol	Inches		Millimeters		Symbol	Inches		Millimeters	
	Min	Max	Min	Max		Min	Max	Min	Max
A	---	.069	---	1.75	E	.150	.157	3.81	4.00
A1	.004	.010	0.10	0.25	E1	.228	.244	5.80	6.20
b	.014	.020	0.35	0.51	e	.050	BSC	1.27	BSC
c	.008 NOM		0.20 NOM		L	0.016	0.044	0.40	1.12
D	0.500	0.510	12.70	12.95					

NOTES:

1. All linear dimensions are in inches (millimeters).
2. This case outline is subject to change without notice.
3. Body dimensions do not include mold flash or protrusion, not to exceed 0.006 inches (0.15 mm).
4. Falls within JEDEC MS-013.

FIGURE 1. Case outlines.

DLA LAND AND MARITIME COLUMBUS, OHIO	SIZE A	CAGE CODE 16236	DWG NO. V62/04663
		REV C	PAGE 7

Case Y

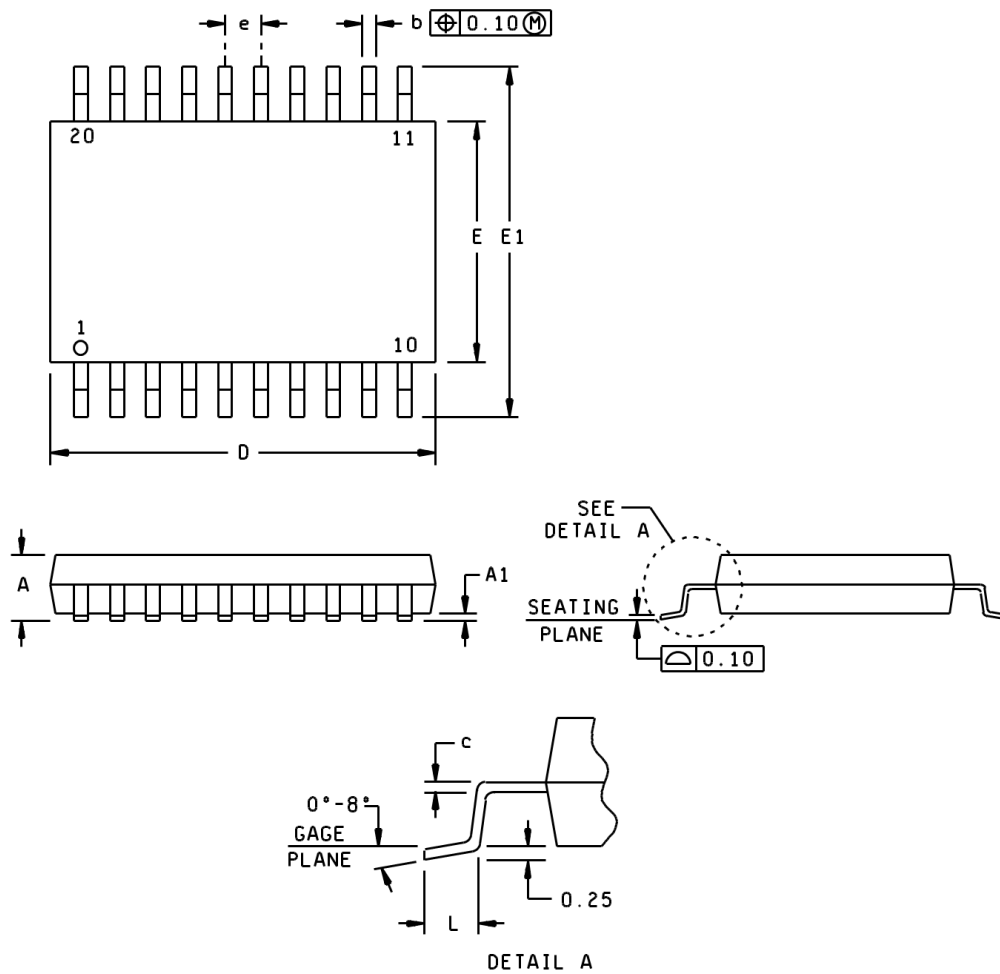

Dimensions									
Symbol	Millimeters		Inches		Symbol	Millimeters		Inches	
	Min	Max	Min	Max		Min	Max	Min	Max
A	---	1.20	---	0.047	E	4.30	4.50	0.169	0.177
A1	0.05	0.15	0.002	0.006	E1	6.20	6.60	0.244	0.260
b	0.19	0.30	0.007	0.012	e	0.65	BSC	0.026	BSC
c	0.15	NOM	0.006	NOM	L	0.50	0.75	0.020	0.030
D	6.40	6.60	0.252	0.260					

NOTES:

1. All linear dimensions are in millimeters.
2. This case outline is subject to change without notice.
3. Body dimensions do not include mold flash or protrusion, not to exceed 0.15 millimeters.
4. Fall within JEDEC MO-153.

FIGURE 1. Case outline - Continued.

DLA LAND AND MARITIME COLUMBUS, OHIO	SIZE A	CAGE CODE 16236	DWG NO. V62/04663
		REV C	PAGE 8

(each flip-flop)

		Inputs		Output	
\overline{OE}	CLK	D	Q		
L	↑	H	H		
L	↑	L	L		
L	H or L	X	Q_0		
H	X	X	Z		

H = High voltage level
 X = Immaterial
 ↑ = Transition from low to high level.
 Q_0 = Level of Q before the indicated steady-state input conditions were established.

L = Low voltage level
 Z = High-impedance state

FIGURE 2. Truth table.

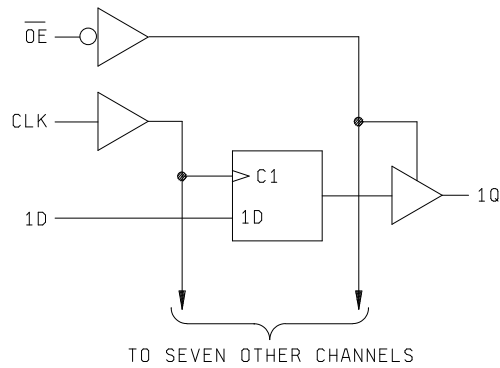

FIGURE 3. Logic diagram.

Case outlines: X and Y

Terminal number	Terminal symbol	Terminal number	Terminal symbol
1	\overline{OE}	11	CLK
2	1Q	12	5Q
3	1D	13	5D
4	2D	14	6D
5	2Q	15	6Q
6	3Q	16	7Q
7	3D	17	7D
8	4D	18	8D
9	4Q	19	8Q
10	GND	20	V _{CC}

FIGURE 4. Terminal connections.

DLA LAND AND MARITIME COLUMBUS, OHIO	SIZE A	CAGE CODE 16236	DWG NO. V62/04663
		REV C	PAGE 9

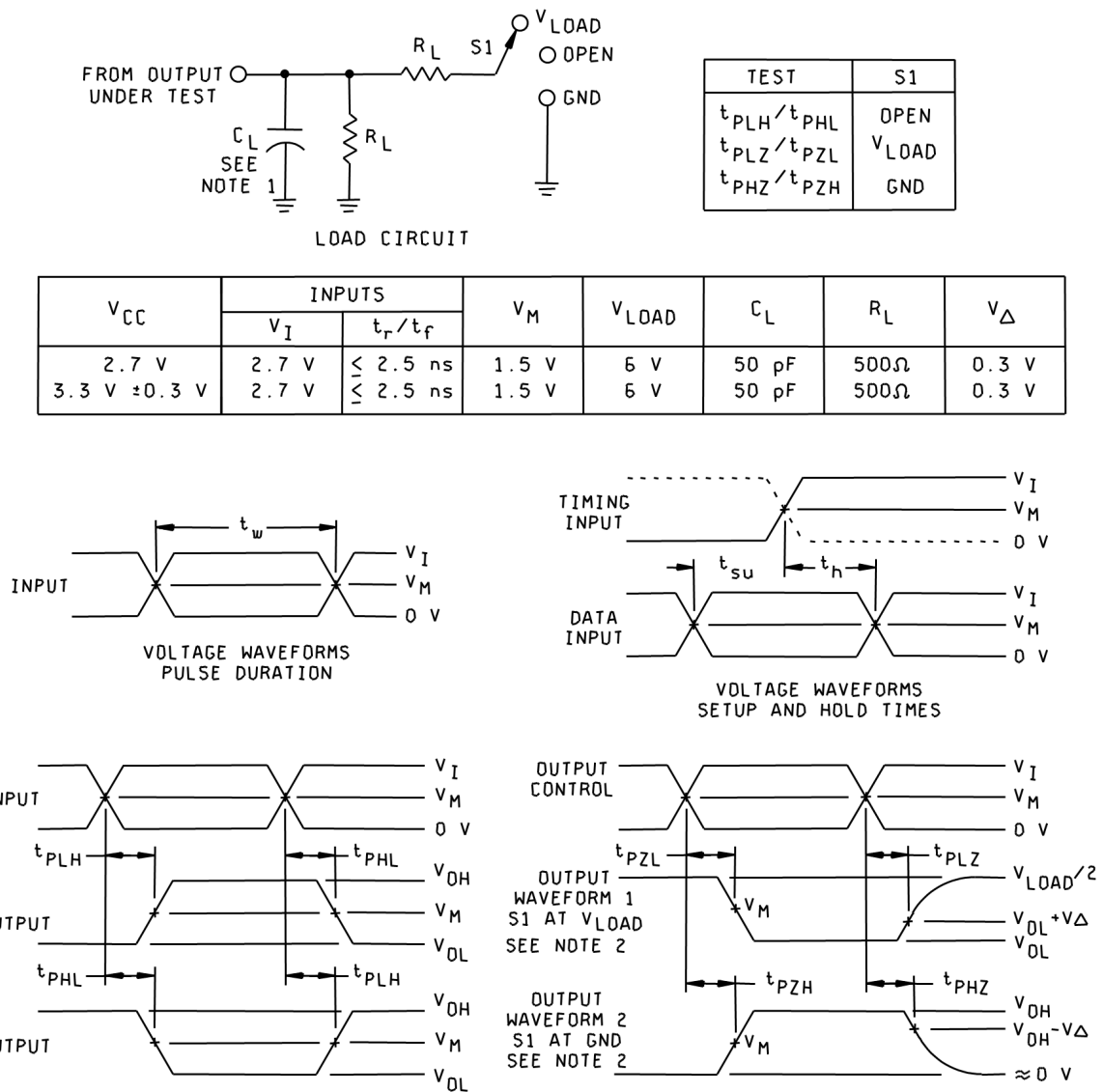

NOTES:

1. C_L includes probe and jig capacitance.
2. Waveform 1 is for an output with internal conditions such that the output is low except when disabled by the output control. Waveform 2 is for an output with internal conditions such that the output is high except when disabled by the output control.
3. All input pulses are supplied by generators having the following characteristics: PRR ≤ 10 MHz, $Z_o = 50 \Omega$.
4. The outputs are measured one at a time with one input transition per measurement.
5. t_{PLZ} and t_{PHZ} are the same as t_{dis} .
6. t_{PZL} and t_{PZH} are the same as t_{en} .
7. t_{PLH} and t_{PHL} are the same as t_{pd} .

FIGURE 5. Test circuit and timing waveforms.

DLA LAND AND MARITIME COLUMBUS, OHIO	SIZE A	CAGE CODE 16236	DWG NO. V62/04663
		REV C	PAGE 10

4. VERIFICATION

4.1 Product assurance requirements. The manufacturer is responsible for performing all inspection and test requirements as indicated in their internal documentation. Such procedures should include proper handling of electrostatic sensitive devices, classification, packaging, and labeling of moisture sensitive devices, as applicable.

5. PREPARATION FOR DELIVERY

5.1 Packaging. Preservation, packaging, labeling, and marking shall be in accordance with the manufacturer's standard commercial practices for electrostatic discharge sensitive devices.

6. NOTES

6.1 ESDS. Devices are electrostatic discharge sensitive and are classified as ESDS class 1 minimum.

6.2 Configuration control. The data contained herein is based on the salient characteristics of the device manufacturer's data book. The device manufacturer reserves the right to make changes without notice. This drawing will be modified as changes are provided.

6.3 Suggested source(s) of supply. Identification of the suggested source(s) of supply herein is not to be construed as a guarantee of present or continued availability as a source of supply for the item. DLA Land and Maritime maintains an online database of all current sources of supply at <https://landandmaritimeapps.dla.mil/programs/smcr/>.

Vendor item drawing administrative control number <u>1/</u>	Device manufacturer CAGE code	Vendor part number	Top side marking
V62/04663-01XE	<u>2/</u>	SN74LVC374AQDWREP	C374AEP
V62/04663-01YE	01295	SN74LVC374AQPWREP	C374AEP

1/ The vendor item drawing establishes an administrative control number for identifying the item on the engineering documentation.

2/ Not available from an approved source of supply.

CAGE code

01295

Source of supply

Texas Instruments, Inc.
Semiconductor Group
8505 Forest Lane
P.O. Box 660199
Dallas, TX 75243

DLA LAND AND MARITIME COLUMBUS, OHIO	SIZE A	CAGE CODE 16236	DWG NO. V62/04663
		REV C	PAGE 11