

REVISIONS

LTR	DESCRIPTION	DATE (YR-MO-DA)	APPROVED
A	Add device type 02 and case outline Z. - phn	07-08-01	Thomas M. Hess
B	Update boilerplate to current MIL-PRF-38535 requirements. - PHN	16-01-25	Muhammad Akbar
C	Update boilerplate paragraphs to current VID description requirements. - PHN	22-09-21	Muhammad A. Akbar



**CURRENT DESIGN ACTIVITY CAGE CODE 16236 HAS CHANGED NAMES TO:
DLA LAND AND MARITIME
COLUMBUS, OHIO 43218-3990**

Prepared in accordance with ASME Y14.24

Vendor Item Drawing

Revision Status of Sheets

REV SHEET																								
REV SHEET																								
REV SHEET	C	C	C	C	C	C	C	C	C	C	C	C												
SHEET	1	2	3	4	5	6	7	8	9	10	11	12												

PMIC N/A Original date of drawing YY MM DD 04-03-15	PREPARED BY Charles F. Saffle					DEFENSE SUPPLY CENTER, COLUMBUS COLUMBUS, OHIO 43218-3990 https://www.dla.mil/LandandMaritime																
	CHECKED BY Charles F. Saffle					TITLE MICROCIRCUIT, DIGITAL, LOW VOLTAGE CMOS, OCTAL TRANSPARENT D-TYPE LATCH WITH 3- STATE OUTPUTS, MONOLITHIC SILICON																
	APPROVED BY Thomas M. Hess																					
	SIZE A		CAGE CODE 16236			DWG NO. V62/04662																
REV C					PAGE 1 OF 12																	

1. SCOPE

1.1 Scope. This drawing documents the general requirements of a high performance octal transparent D-type latch with 3-state outputs multiplexer microcircuit, with an operating temperature range of -40°C to +125°C for device type 01 and an extended operating temperature range of -55°C to +125°C for device type 02.

1.2 Vendor Item Drawing Administrative Control Number. The manufacturer's PIN is the item of identification. The vendor item drawing establishes an administrative control number for identifying the item on the engineering documentation:

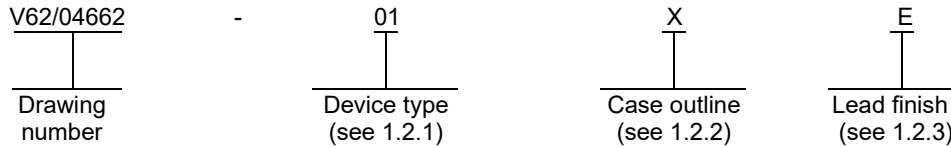

1.2.1 Device type(s).

	<u>Device type</u>	<u>Generic</u>	<u>Circuit function</u>
01	-40°C to +125°C	SN74LVC373A-EP	Octal transparent D-type latch with 3-state outputs
02	-55°C to +125°C	SN74LVC373A-EP	Octal transparent D-type latch with 3-state outputs

1.2.2 Case outlines. The case outlines are as specified herein.

<u>Outline letter</u>	<u>Number of pins</u>	<u>JEDEC PUB 95</u>	<u>Package style</u>
X	20	MS-013	Plastic small-outline
Y	20	MO-153	Plastic small-outline
Z	20	MO-150	Plastic small-outline

1.2.3 Lead finishes. The lead finishes are as specified below or other lead finishes as provided by the device manufacturer:

<u>Finish designator</u>	<u>Material</u>
A	Hot solder dip
B	Tin-lead plate
C	Gold plate
D	Palladium
E	Gold flash palladium
F	Tin-lead alloy
Z	Other

DLA LAND AND MARITIME COLUMBUS, OHIO	SIZE A	CAGE CODE 16236	DWG NO. V62/04662
		REV C	PAGE 2

1.3 Absolute maximum ratings. 1/

Supply voltage range (V_{CC})	-0.5 V to 6.5 V
Input voltage range (V_i).....	-0.5 V to 6.5 V 2/
Voltage range applied to any output in the high-impedance or power-off state (V_o).....	-0.5 V to 6.5 V 2/
Voltage range applied to any output in the high or low state (V_o).....	-0.5 V to $V_{CC} + 0.5 V$ 2/ 3/
Input clamp current (I_{IK}) ($V_i < 0$)	-50 mA
Output clamp current (I_{OK}) ($V_o < 0$)	-50 mA
Continuous output current (I_o).....	± 50 mA
Continuous current through V_{CC} or GND.....	± 100 mA
Package thermal impedance (θ_{JA}): 4/	
X package	58°C/W
Y package	83°C/W
Z package	120°C/W
Storage temperature range (T_{STG}).....	-65°C to 150°C 5/

1.4 Recommended operating conditions. 6/

Supply voltage range (V_{CC}):	
Operating	2.0 V to 3.6 V
Data retention only	1.5 V minimum
Minimum high level input voltage (V_{IH}) ($V_{CC} = 2.7 V$ to 3.6 V)	2.0 V
Maximum low level input voltage (V_{IL}) ($V_{CC} = 2.7 V$ to 3.6 V).....	0.8 V
Input voltage range (V_i).....	0.0 V to 5.5 V
Output voltage range (V_o):	
High or low state.....	0.0 V to V_{CC}
3-state	0.0 V to 5.5 V
Maximum high level output current (I_{OH}):	
$V_{CC} = 2.7 V$	-12 mA
$V_{CC} = 3.0 V$	-24 mA
Maximum low level output current (I_{OL}):	
$V_{CC} = 2.7 V$	12 mA
$V_{CC} = 3.0 V$	24 mA
Maximum input transition rise or fall rate ($\Delta t/\Delta v$).....	10 ns/V
Operating free-air temperature range (T_A):	
Device type 01.....	-40°C to +125°C
Device type 02.....	-55°C to +125°C

- 1/ Stresses beyond those listed under “absolute maximum ratings” may cause permanent damage to the device. These are stress ratings only, and functional operation of the device at these or any other conditions beyond those indicated under “recommended operating conditions” is not implied. Exposure to absolute-maximum-rated conditions for extended periods may affect device reliability.
- 2/ The input negative-voltage and output voltage ratings may be exceeded if the input and output current ratings are observed.
- 3/ The value of V_{CC} is provided in the recommended operating conditions table.
- 4/ The package thermal impedance is calculated in accordance with JESD 51-7.
- 5/ Long-term high-temperature storage and/or extended use at maximum recommended operating conditions may result in a reduction of overall device life.
- 6/ All unused inputs of the device must be held at V_{CC} or GND to ensure proper device operation.

DLA LAND AND MARITIME COLUMBUS, OHIO	SIZE A	CAGE CODE 16236	DWG NO. V62/04662
		REV C	PAGE 3

2. APPLICABLE DOCUMENTS

JEDEC – SOLID STATE TECHNOLOGY ASSOCIATION (JEDEC)

- JEP95 - Registered and Standard Outlines for Semiconductor Devices
- JESD51-7 - High Effective Thermal Conductivity Test Board for Leaded Surface Mount Packages

(Copies of these documents are available online at <https://www.jedec.org>).

3. REQUIREMENTS

3.1 Marking. Parts shall be permanently and legibly marked with the manufacturer’s part number as shown in 6.3 herein and as follows:

- A. Manufacturer’s name, CAGE code, or logo
- B. Pin 1 identifier
- C. ESDS identification (optional)

3.2 Unit container. The unit container shall be marked with the manufacturer’s part number and with items A and C (if applicable) above.

3.3 Electrical characteristics. The maximum and recommended operating conditions and electrical performance characteristics are as specified in 1.3, 1.4, and table I herein.

3.4 Design, construction, and physical dimension. The design, construction, and physical dimensions are as specified herein.

3.5 Diagrams.

3.5.1 Case outlines. The case outlines shall be as shown in 1.2.2 and figure 1.

3.5.2 Truth table. The truth table shall be as shown in figure 2.

3.5.3 Logic diagram. The logic diagram shall be as shown in figure 3.

3.5.4 Terminal connections. The terminal connections shall be as shown in figure 4.

3.5.5 Test circuit and timing waveforms. The test circuit and timing waveforms shall be as shown in figure 5.

DLA LAND AND MARITIME COLUMBUS, OHIO	SIZE A	CAGE CODE 16236		DWG NO. V62/04662
		REV	C	PAGE 4

TABLE I. Electrical performance characteristics. 1/

Test	Symbol	Conditions Device type: All <u>2/</u>	V _{CC}	Limits		Unit
				Min	Max	
High level output voltage	V _{OH}	I _{OH} = -100 μA	2.7 V to 3.6 V	V _{CC} - 0.2		V
		I _{OH} = -12 mA	2.7 V	2.2		
			3.0 V	2.4		
		I _{OH} = -24 mA	3.0 V	2.2		
Low level output voltage	V _{OL}	I _{OL} = 100 μA	2.7 V to 3.6 V		0.2	V
		I _{OL} = 12 mA	2.7 V		0.4	
			3.0 V		0.55	
		I _{OL} = 24 mA	3.0 V			
Input current	I _I	V _I = 0 to 5.5 V	3.6 V		±5	μA
Three-state output leakage current	I _{OZ}	V _O = 0 to 5.5 V	3.6 V		±15	μA
Quiescent supply current	I _{CC}	V _I = V _{CC} or GND I _O = 0 A	3.6 V		10	μA
		3.6 V ≤ V _I ≤ 5.5 V <u>3/</u> I _O = 0 A			10	
Quiescent supply current delta	ΔI _{CC}	One input at V _{CC} - 0.6 V, Other inputs at V _{CC} or GND	2.7 V to 3.6 V		500	μA
Input capacitance	C _i	V _O = V _{CC} or GND	3.3 V		12	pF
Output capacitance	C _O		3.3 V		12	
Power dissipation capacitance per latch	C _{pd}	Outputs enabled f = 10 MHz	3.3 V		46 TYP	pF
		Outputs disabled f = 10 MHz	3.3 V		3 TYP	

See footnotes at end of table.

DLA LAND AND MARITIME COLUMBUS, OHIO	SIZE A	CAGE CODE 16236	DWG NO. V62/04662
		REV C	PAGE 5

TABLE I. Electrical performance characteristics - Continued.

Test	Symbol	Conditions 2/ Device type: All	Limits				Unit
			V _{CC} = 2.7 V		V _{CC} = 3.3 V ±0.3 V		
			Min	Max	Min	Max	
Timing requirements							
Pulse duration, LE high	t _w		3.3		3.3		ns
Setup time, data before LE ↓	t _{su}		2		2		
Hold time, data after LE ↓	t _h		2		2		
Switching characteristics							
Propagation delay time, from input D to Q	t _{pd}			8.5	1	7.5	ns
Propagation delay time, from input LE to Q				9.5	1	8.5	
Enable time from input \overline{OE} to Q	t _{en}			8.7	1	7.7	
Disable time from input \overline{OE} to Q	t _{dis}			8.0	0.5	7.0	

- 1/ Testing and other quality control techniques are used to the extent deemed necessary to assure product performance over the specified temperature range. Product may not necessarily be tested across the full temperature range and all parameters may not necessarily be tested. In the absence of specific parametric testing, product performance is assured by characterization and/or design.
- 2/ Over recommended operating free air temperature range. T_A = -40°C to +125°C for device type 01 and -55°C to +125°C for device type 02. Unless otherwise noted.
- 3/ This applies in the disabled state only.

DLA LAND AND MARITIME COLUMBUS, OHIO	SIZE A	CAGE CODE 16236		DWG NO. V62/04662
		REV	C	PAGE 6

Case X

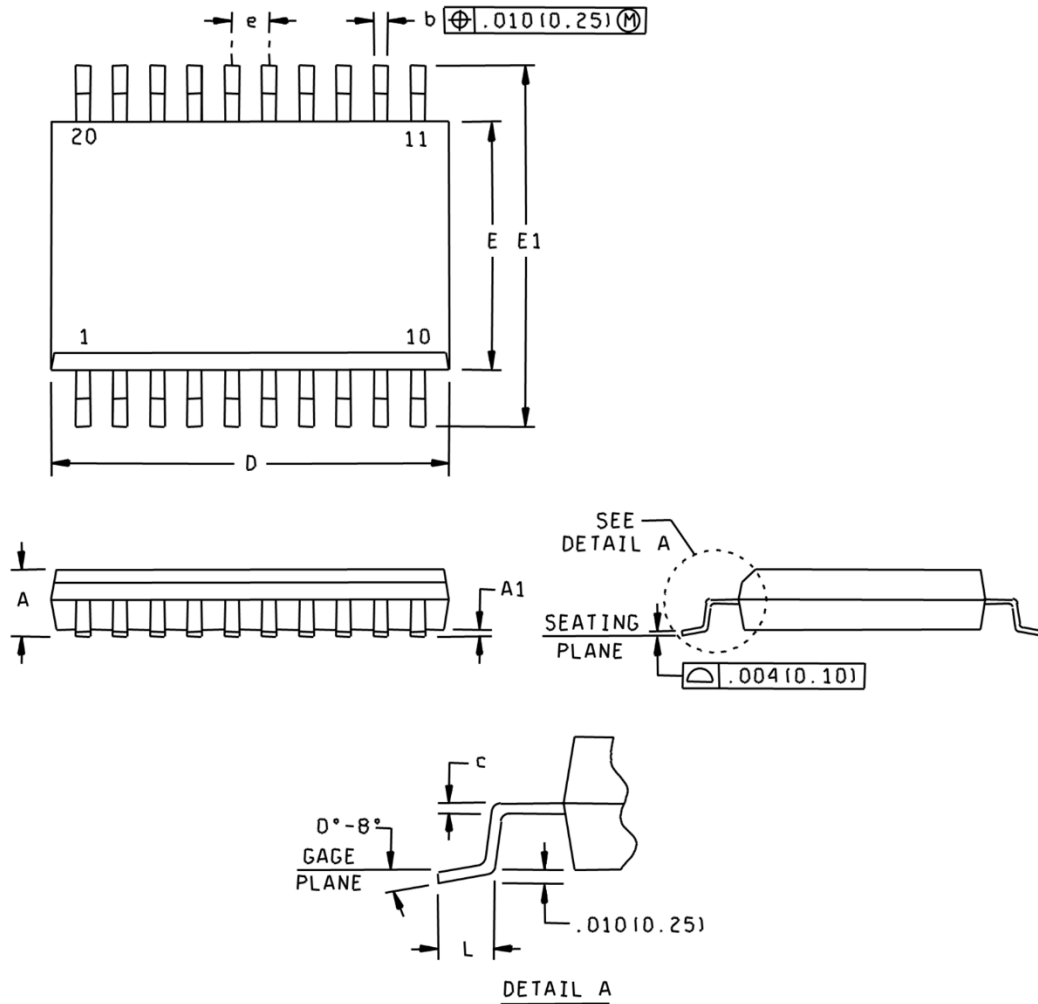

Dimensions									
Symbol	Inches		Millimeters		Symbol	Inches		Millimeters	
	Min	Max	Min	Max		Min	Max	Min	Max
A	---	.069	---	1.75	E	.150	.157	3.81	4.00
A1	.004	.010	0.10	0.25	E1	.228	.244	5.80	6.20
b	.014	.020	0.35	0.51	e	.050	BSC	1.27	BSC
c	.008	NOM	0.20	NOM	L	0.40	1.27	.016	.050
D	0.500	0.510	12.70	12.95					

NOTES:

1. This drawing is subject to change without notice.
2. Body dimensions do not include mold flash or protrusion not to exceed 0.006 inches (0.15 mm).
3. Falls within JEDEC MS-013.

FIGURE 1. Case outlines.

DLA LAND AND MARITIME COLUMBUS, OHIO	SIZE A	CAGE CODE 16236	DWG NO. V62/04662
		REV C	PAGE 7

Case Y_

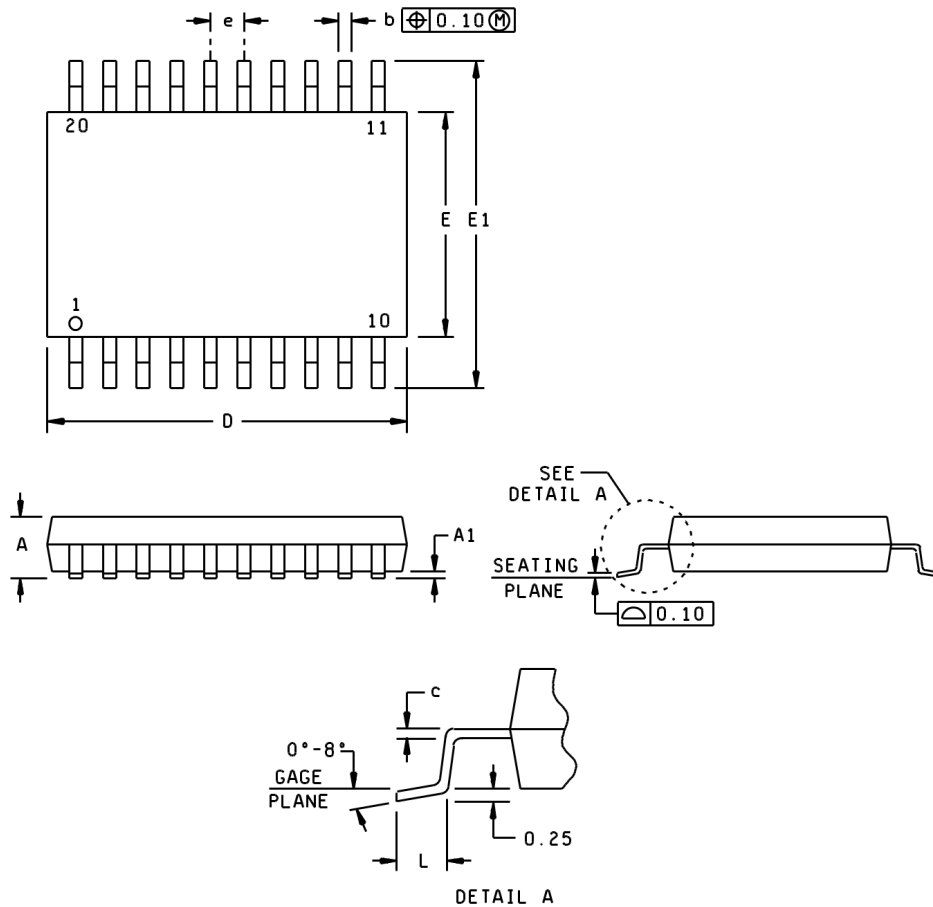

Dimensions					
Symbol	Min	Max	Symbol	Min	Max
A	---	1.20	E	4.30	4.50
A1	0.05	0.15	E1	6.20	6.60
b	0.19	0.30	e	0.65 BSC	
c	0.15 NOM		L	0.50	0.75
D	6.40	6.60			

NOTES:

1. All linear dimensions are in millimeters.
2. This case outline is subject to change without notice.
3. Body dimensions do not include mold flash or protrusion, not to exceed 0.15 millimeters.
4. Fall within JEDEC MO-153.

FIGURE 1. Case outline - Continued.

DLA LAND AND MARITIME COLUMBUS, OHIO	SIZE A	CAGE CODE 16236	DWG NO. V62/04662
		REV C	PAGE 8

Case Z

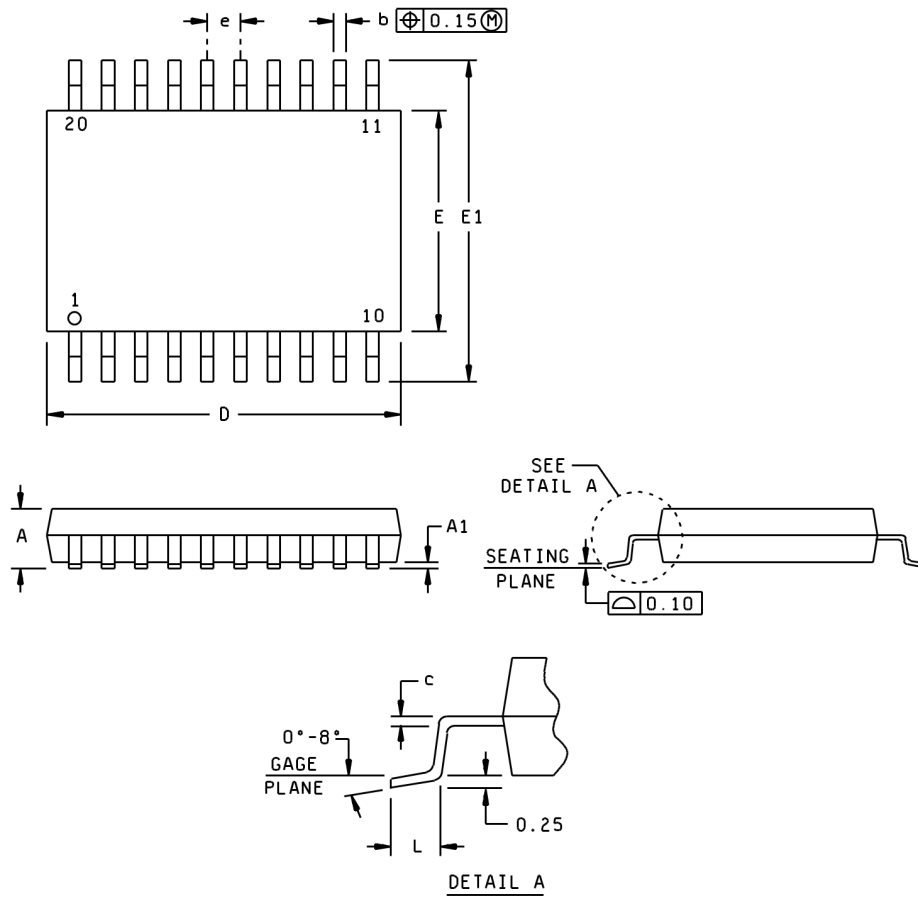

Dimensions					
Symbol	Min	Max	Symbol	Min	Max
A	---	2.0	E	5.00	5.60
A1	0.05		E1	7.40	8.20
b	0.22	0.38	e	0.65 BSC	
c	0.09	0.25	L	0.55	0.95
D	6.90	7.50			

NOTES:

1. All linear dimensions are in millimeters.
2. This case outline is subject to change without notice.
3. Body dimensions do not include mold flash or protrusion, not to exceed 0.15 millimeters.
4. Fall within JEDEC MO-150.

FIGURE 1. Case outline - Continued.

DLA LAND AND MARITIME COLUMBUS, OHIO	SIZE A	CAGE CODE 16236	DWG NO. V62/04662
		REV C	PAGE 9

(each latch)

Inputs			Output
\overline{OE}	LE	D	Q
L	H	H	H
L	H	L	L
L	L	X	Q ₀
H	X	X	Z

H = High voltage level

L = Low voltage level

X = Immaterial

Z = High-impedance state

Q₀ = Level of Q before the indicated steady-state input conditions were established.

FIGURE 2. Truth table.

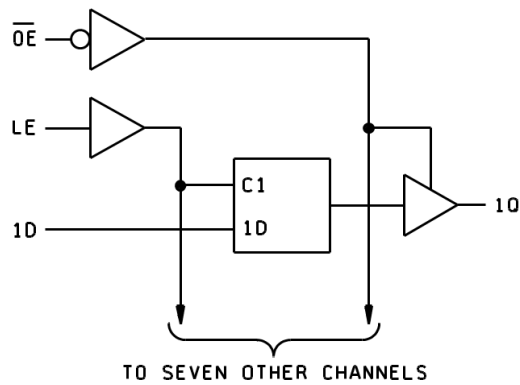

FIGURE 3. Logic diagram.

Case outline X, Y, and Z

Terminal number	Terminal symbol	Terminal number	Terminal symbol
1	\overline{OE}	11	LE
2	1Q	12	5Q
3	1D	13	5D
4	2D	14	6D
5	2Q	15	6Q
6	3Q	16	7Q
7	3D	17	7D
8	4D	18	8D
9	4Q	19	8Q
10	GND	20	V _{CC}

FIGURE 4. Terminal connections.

DLA LAND AND MARITIME COLUMBUS, OHIO	SIZE A	CAGE CODE 16236	DWG NO. V62/04662
		REV C	PAGE 10

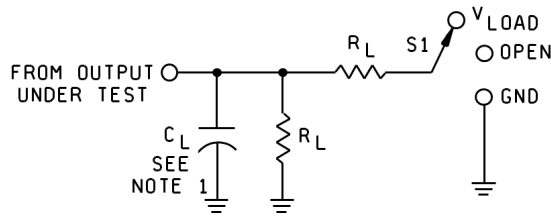

TEST	S1
t_{PLH}/t_{PHL}	OPEN
t_{PLZ}/t_{PZL}	V_{LOAD}
t_{PHZ}/t_{PZH}	GND

LOAD CIRCUIT

V_{CC}	INPUTS		V_M	V_{LOAD}	C_L	R_L	V_{Δ}
	V_I	t_r/t_f					
2.7 V	2.7 V	≤ 2.5 ns	1.5 V	6 V	50 pF	500 Ω	0.3 V
3.3 V ± 0.3 V	2.7 V	≤ 2.5 ns	1.5 V	6 V	50 pF	500 Ω	0.3 V

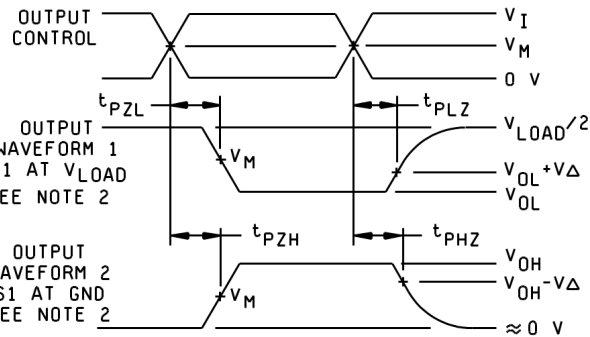
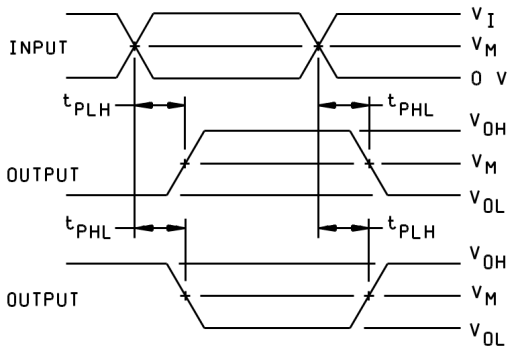
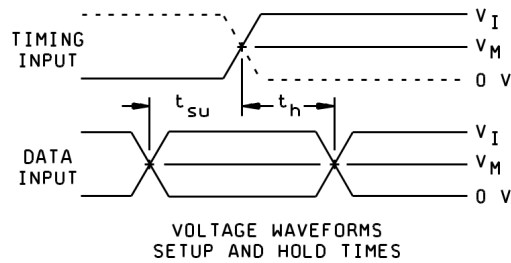
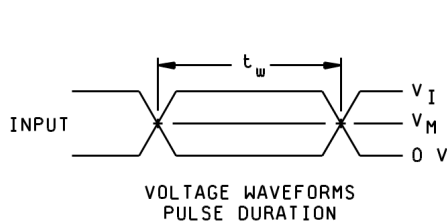

NOTES:

1. C_L includes probe and jig capacitance.
2. Waveform 1 is for an output with internal conditions such that the output is low except when disabled by the output control. Waveform 2 is for an output with internal conditions such that the output is high except when disabled by the output control.
3. All input pulses are supplied by generators having the following characteristics: $PRR \leq 10$ MHz, $Z_0 = 50 \Omega$.
4. The outputs are measured one at a time with one input transition per measurement.
5. t_{PLZ} and t_{PHZ} are the same as t_{dis} .
6. t_{PZL} and t_{PZH} are the same as t_{en} .
7. t_{PLH} and t_{PHL} are the same as t_{pd} .

FIGURE 5. Test circuit and timing waveforms.

DLA LAND AND MARITIME COLUMBUS, OHIO	SIZE A	CAGE CODE 16236	DWG NO. V62/04662
		REV C	PAGE 11

4. VERIFICATION

4.1 Product assurance requirements. The manufacturer is responsible for performing all inspection and test requirements as indicated in their internal documentation. Such procedures should include proper handling of electrostatic sensitive devices, classification, packaging, and labeling of moisture sensitive devices, as applicable.

5. PREPARATION FOR DELIVERY

5.1 Packaging. Preservation, packaging, labeling, and marking shall be in accordance with the manufacturer’s standard commercial practices for electrostatic discharge sensitive devices.

6. NOTES

6.1 ESDS. Devices are electrostatic discharge sensitive and are classified as ESDS class 1 minimum.

6.2 Configuration control. The data contained herein is based on the salient characteristics of the device manufacturer’s data book. The device manufacturer reserves the right to make changes without notice. This drawing will be modified as changes are provided.

6.3 Suggested source(s) of supply. Identification of the suggested source(s) of supply herein is not to be construed as a guarantee of present or continued availability as a source of supply for the item. DLA Land and Maritime maintains an online database of all current sources of supply at <https://landandmaritimeapps.dla.mil/programs/smcr/>.

Vendor item drawing administrative control number <u>1/</u>	Device manufacturer CAGE code	Vendor part number	Top side marking
V62/04662-01XE	<u>2/</u>	SN74LVC373AQDWREP	C373AEP
V62/04662-01YE	01295	SN74LVC373AQPWREP	C373AEP
V62/04662-02ZE	01295	SN74LVC373AMDBREP	C373AEP

1/ The vendor item drawing establishes an administrative control number for identifying the item on the engineering documentation.

2/ Not available from an approved source of supply.

CAGE code

01295

Source of supply

Texas Instruments, Inc.
Semiconductor Group
8505 Forest Lane
P.O. Box 660199
Dallas, TX 75243

DLA LAND AND MARITIME COLUMBUS, OHIO	SIZE A	CAGE CODE 16236	DWG NO. V62/04662
		REV C	PAGE 12