

1. SCOPE

1.1 Scope. This drawing documents the general requirements of a high performance octal D-type transparent latch with TTL compatible inputs and 3-state outputs microcircuit, with an operating temperature range of -55°C to +125°C.

1.2 Vendor Item Drawing Administrative Control Number. The manufacturer's PIN is the item of identification. The vendor item drawing establishes an administrative control number for identifying the item on the engineering documentation:

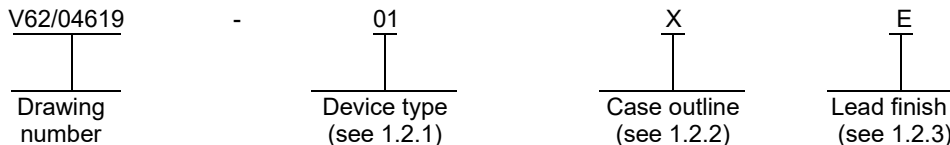

1.2.1 Device type(s).

<u>Device type</u>	<u>Generic</u>	<u>Circuit function</u>
01	74ACT373-EP	Octal D-type transparent latch with TTL compatible inputs and 3-state outputs

1.2.2 Case outlines. The case outlines are as specified herein.

<u>Outline letter</u>	<u>Number of pins</u>	<u>JEDEC PUB 95</u>	<u>Package style</u>
X	20	JEDEC MS-013	Plastic small-outline

1.2.3 Lead finishes. The lead finishes are as specified below or other lead finishes as provided by the device manufacturer:

<u>Finish designator</u>	<u>Material</u>
A	Hot solder dip
B	Tin-lead plate
C	Gold plate
D	Palladium
E	Gold flash palladium
F	Tin-lead alloy
Z	Other

1.3 Absolute maximum ratings. 1/

Supply voltage range (V_{CC})	-0.5 V to +7.0 V
Input voltage range (V_I)	-0.5 V to $V_{CC} + 0.5 V$ 2/
Output voltage range (V_O)	-0.5 V to $V_{CC} + 0.5 V$ 2/
Input clamp current (I_{IK}) ($V_I < 0$ or $V_I > V_{CC}$)	± 20 mA
Output clamp current (I_{OK}) ($V_O < 0$ or $V_O > V_{CC}$)	± 20 mA
Continuous output current (I_O) ($V_O = 0$ to V_{CC})	± 50 mA
Continuous current through V_{CC} or GND	± 200 mA
Package thermal impedance (Θ_{JA})	58°C/W 3/
Storage temperature range (T_{STG})	-65°C to +150°C 4/

- 1/ Stresses beyond those listed under "absolute maximum rating" may cause permanent damage to the device. These are stress ratings only, and functional operation of the device at these or any other conditions beyond those indicated under "recommended operating conditions" is not implied. Exposure to absolute-maximum-rated conditions for extended periods may affect device reliability.
- 2/ The input and output voltage ratings may be exceeded if the input and output current ratings are observed.
- 3/ The package thermal impedance is calculated in accordance with JESD 51-7.
- 4/ Long-term high-temperature storage and/or extended use at maximum recommended operating conditions may result in a reduction of overall device life.

DLA LAND AND MARITIME COLUMBUS, OHIO	SIZE A	CAGE CODE 16236	DWG NO. V62/04619
	REV	C	PAGE 2

1.4 Recommended operating conditions. 4/ 5/

Supply voltage range (V_{CC})	4.5 V to 5.5 V
Minimum high level input voltage (V_{IH})	2.0 V
Maximum low level input voltage (V_{IL})	0.8 V
Input voltage range (V_i)	0.0 V to V_{CC}
Output voltage range (V_o)	0.0 V to V_{CC}
Maximum high level output current (I_{OH})	-24 mA
Maximum low level output current (I_{OL})	24 mA
Maximum input transition rise or fall rate ($\Delta t/\Delta v$)	8 ns/V
Operating free-air temperature range (T_A)	-55°C to +125°C

2. APPLICABLE DOCUMENTS

JEDEC – SOLID STATE TECHNOLOGY ASSOCIATION (JEDEC)

- JEP95 - Registered and Standard Outlines for Semiconductor Devices
- JESD 51-7 - High Effective Thermal Conductivity Test Board for Leaded Surface Mount Packages

(Copies of these documents are available online at <http://www.jedec.org>).

3. REQUIREMENTS

3.1 Marking. Parts shall be permanently and legibly marked with the manufacturer’s part number as shown in 6.3 herein and as follows:

- A. Manufacturer’s name, CAGE code, or logo
- B. Pin 1 identifier
- C. ESDS identification (optional)

3.2 Unit container. The unit container shall be marked with the manufacturer’s part number and with items A and C (if applicable) above.

3.3 Electrical characteristics. The maximum and recommended operating conditions and electrical performance characteristics are as specified in 1.3, 1.4, and table I herein.

3.4 Design, construction, and physical dimension. The design, construction, and physical dimensions are as specified herein.

3.5 Diagrams.

3.5.1 Case outline. The case outline shall be as shown in 1.2.2 and figure 1.

3.5.2 Truth table. The truth table shall be as shown in figure 2.

3.5.3 Logic diagram. The logic diagram shall be as shown in figure 3.

3.5.4 Terminal connections. The terminal connections shall be as shown in figure 4.

3.5.5 Timing waveforms and test circuit. The timing waveforms and test circuit shall be as shown in figure 5.

4/ All unused inputs of the device must be held at V_{CC} or GND to ensure proper device operation.

5/ Use of this product beyond the manufacturers design rules or stated parameters is done at the user’s risk. The manufacturer and/or distributor maintain no responsibility or liability for product used beyond the stated limits.

DLA LAND AND MARITIME COLUMBUS, OHIO	SIZE A	CAGE CODE 16236		DWG NO. V62/04619
		REV	C	PAGE 3

TABLE I. Electrical performance characteristics. 1/

Test	Symbol	Conditions Device type: 01	V _{CC}	Temperature, T _A	Limits		Unit	
					Min	Max		
High level output voltage	V _{OH}	I _{OH} = -50 μA	4.5 V	25°C,	4.4		V	
			5.5 V	-55°C to 125°C	5.4			
		I _{OH} = -24 mA	4.5 V	25°C	3.86			
				-55°C to 125°C	3.7			
			5.5 V	25°C	4.86			
-55°C to 125°C	4.7							
Low level output voltage	V _{OL}	I _{OL} = 50 μA	4.5 V	25°C,		0.1	V	
			5.5 V	-55°C to 125°C		0.1		
		I _{OL} = 24 mA	4.5 V	25°C		0.36		
				-55°C to 125°C		0.44		
			5.5 V	25°C		0.36		
-55°C to 125°C		0.44						
Input current	I _I	V _I = V _{CC} or GND	5.5 V	25°C		±0.1	μA	
				-55°C to 125°C		±1.0		
Off-state output current	I _{oz}	V _O = V _{CC} or GND	5.5 V	25°C		±0.25	μA	
				-55°C to 125°C		±5.0		
Quiescent supply current	I _{CC}	V _I = V _{CC} or GND I _o = 0 A	5.5 V	25°C		4.0	μA	
				-55°C to 125°C		80.0		
Quiescent supply current delta	ΔI _{CC} 2/	One input at 3.4 V. Other inputs at GND or V _{CC}	5.5 V	25°C	0.6	TYP	mA	
				-55°C to 125°C		1.5		
Input capacitance	C _I	V _I = V _{CC} or GND	5.0 V	25°C	4.5	TYP	pF	
Power dissipation capacitance	C _{pd}	C _L = 50 pF f = 1 MHz	5.0 V	25°C	40	TYP	pF	

See footnotes at end of table.

DLA LAND AND MARITIME COLUMBUS, OHIO	SIZE A	CAGE CODE 16236	DWG NO. V62/04619
		REV C	PAGE 4

TABLE I. Electrical performance characteristics - Continued. 1/

Test	Symbol	Conditions Device type: 01	V _{CC}	Temperature, T _A	Limits		Unit
					Min	Max	
Pulse duration, LE high	t _{sw}	See figure 5	4.5 V and 5.5 V	25°C	7.0		ns
				-55°C to 125°C	8.5		
Setup time, data before LE↓	t _{su}	See figure 5	4.5 V and 5.5 V	25°C	7.0		ns
				-55°C to 125°C	8.5		
Hold time, data after LE↓	t _h	See figure 5	4.5 V and 5.5 V	25°C	0.0		ns
				-55°C to 125°C	1.0		
Propagation delay time, D to Q	t _{PLH}	See figure 5	4.5 V and 5.5 V	25°C	2.5	10.0	ns
				-55°C to 125°C	1.5	12.5	
	t _{PHL}		4.5 V and 5.5 V	25°C	2.0	10.0	
				-55°C to 125°C	1.5	12.5	
Propagation delay time, LE to Q	t _{PLH}	See figure 5	4.5 V and 5.5 V	25°C	2.5	11.0	ns
				-55°C to 125°C	1.5	12.5	
	t _{PHL}		4.5 V and 5.5 V	25°C	2.0	10.0	
				-55°C to 125°C	1.5	11.5	
Output enable time, OE to Q	t _{PZH}	See figure 5	4.5 V and 5.5 V	25°C	2.0	9.5	ns
				-55°C to 125°C	1.5	11.5	
	t _{PZL}		4.5 V and 5.5 V	25°C	2.0	9.0	
				-55°C to 125°C	1.5	11.0	
Output disable time, OE to Q	t _{PHZ}	See figure 5	4.5 V and 5.5 V	25°C	2.5	11.0	ns
				-55°C to 125°C	1.5	14.0	
	t _{PLZ}		4.5 V and 5.5 V	25°C	1.5	8.5	
				-55°C to 125°C	1.5	11.0	

- 1/ Testing and other quality control techniques are used to the extent deemed necessary to assure product performance over the specified temperature range. Product may not necessarily be tested across the full temperature range and all parameters may not necessarily be tested. In the absence of specific parametric testing, product performance is assured by characterization and/or design.
- 2/ This is the increase in supply current for each input that is at one of the specified TTL voltage levels, rather than 0 V or V_{CC}.

DLA LAND AND MARITIME COLUMBUS, OHIO	SIZE A	CAGE CODE 16236	DWG NO. V62/04619
		REV C	PAGE 5

Case X

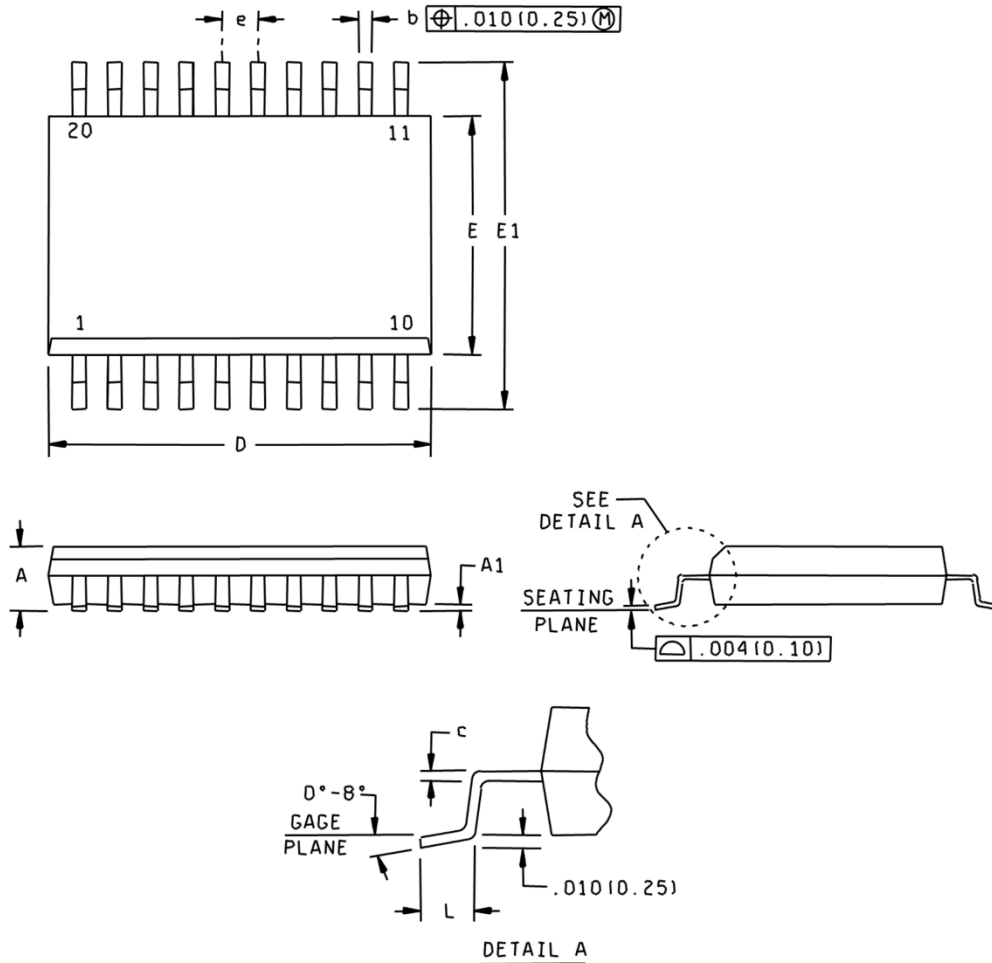

Dimensions									
Symbol	Millimeters		Inches		Symbol	Millimeters		Inches	
	Min	Max	Min	Max		Min	Max	Min	Max
A	---	2.65	---	0.104	E	7.39	7.59	0.291	0.299
A1	0.05	0.15	0.004	0.012	E1	10.15	10.65	0.400	0.419
b	0.35	0.51	0.014	0.020	e	1.27	NOM	.050	NOM
c	0.25	NOM	.010	NOM	L	0.40	1.27	.016	.050
D	12.70	12.95	0.500	0.510					

NOTES:

1. All linear dimensions are in inches (millimeters).
2. This case outline is subject to change without notice.
3. Body dimensions do not include mold flash or protrusion, not to exceed 0.006 inches (0.15 mm).
4. Falls within JEDEC MS-013.

FIGURE 1. Case outlines.

DLA LAND AND MARITIME COLUMBUS, OHIO	SIZE A	CAGE CODE 16236	DWG NO. V62/04619
		REV C	PAGE 6

(each latch)

Inputs			Output
\overline{OE}	LE	D	Q
L	H	H	H
L	H	L	L
L	L	X	Q_0
H	X	X	Z

FIGURE 2. Truth table.

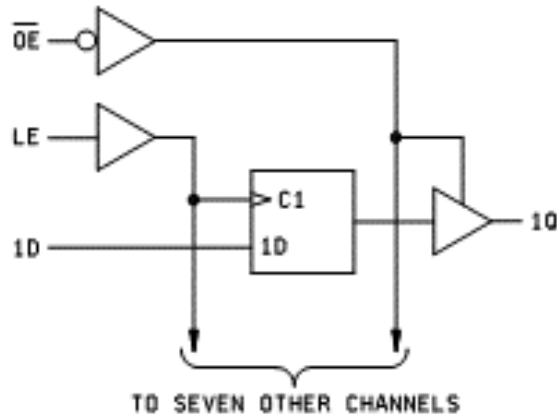
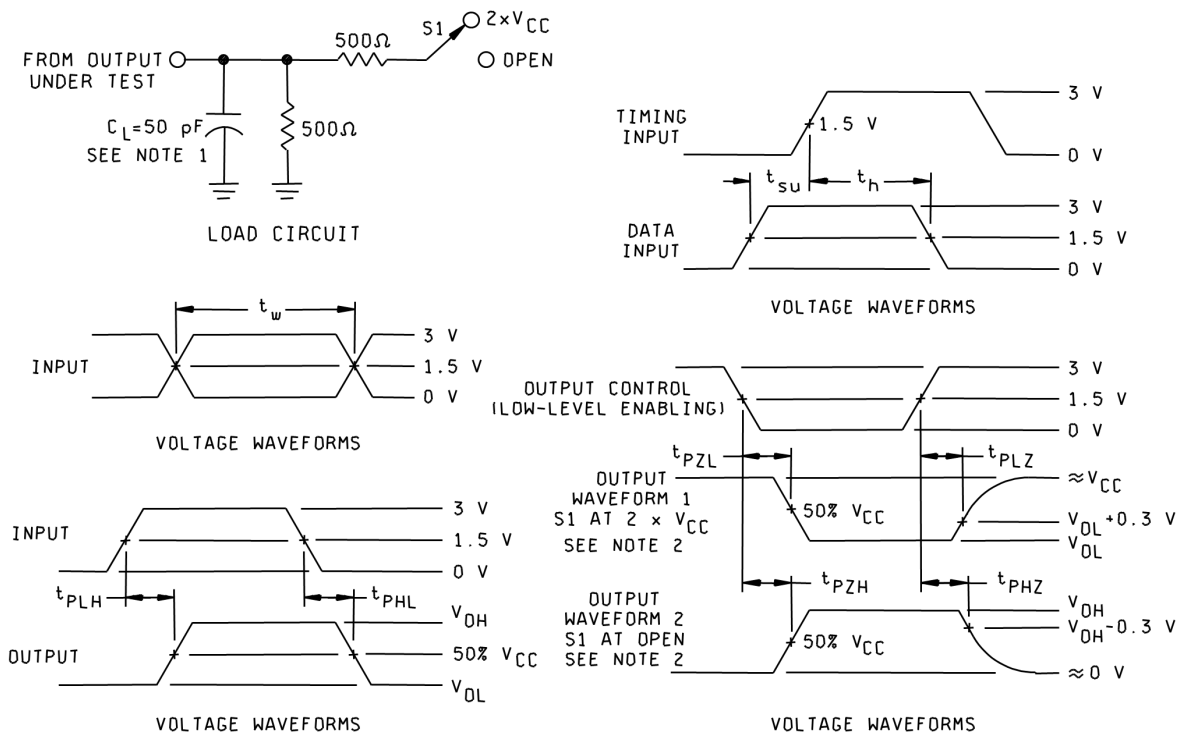

FIGURE 3. Logic diagram.

Terminal number	Terminal symbol	Terminal number	Terminal symbol
1	\overline{OE}	11	LE
2	1Q	12	5Q
3	1D	13	5D
4	2D	14	6D
5	2Q	15	6Q
6	3Q	16	7Q
7	3D	17	7D
8	4D	18	8D
9	4Q	19	8Q
10	GND	20	V_{CC}

FIGURE 4. Terminal connections.

DLA LAND AND MARITIME COLUMBUS, OHIO	SIZE A	CAGE CODE 16236	DWG NO. V62/04619
		REV C	PAGE 7



Notes:

1. C_L includes probe and jig capacitance.
2. Waveform 1 is for an output with internal conditions such that the output is low except when disabled by the output control. Waveform 2 is for an output with internal conditions such that the output is high except when disabled by the output control.
3. All input pulses are supplied by generators having the following characteristics: $PRR \leq 1 \text{ MHz}$, $Z_O = 50\Omega$, $t_r \leq 3 \text{ ns}$, $t_f \leq 3 \text{ ns}$.
4. The outputs are measured one at a time with one input transition per measurement.
5. For 3-state and Open Drain outputs tests:

t_{PLH}/t_{PHL}	S1 = Open
t_{PLZ}/t_{PZL}	S1 = V_{CC}
t_{PHZ}/t_{PZH}	S1 = GND
Open Drain	S1 = V_{CC}

FIGURE 5. Timing waveforms and test circuit.

DLA LAND AND MARITIME COLUMBUS, OHIO	SIZE A	CAGE CODE 16236	DWG NO. V62/04619
		REV C	PAGE 8

4. VERIFICATION

4.1 Product assurance requirements. The manufacturer is responsible for performing all inspection and test requirements as indicated in their internal documentation. Such procedures should include proper handling of electrostatic sensitive devices, classification, packaging, and labeling of moisture sensitive devices, as applicable.

5. PREPARATION FOR DELIVERY

5.1 Packaging. Preservation, packaging, labeling, and marking shall be in accordance with the manufacturer’s standard commercial practices for electrostatic discharge sensitive devices.

6. NOTES

6.1 ESDS. Devices are electrostatic discharge sensitive and are classified as ESDS class 1 minimum.

6.2 Configuration control. The data contained herein is based on the salient characteristics of the device manufacturer’s data book. The device manufacturer reserves the right to make changes without notice. This drawing will be modified as changes are provided.

6.3 Suggested source(s) of supply. Identification of the suggested source(s) of supply herein is not to be construed as a guarantee of present or continued availability as a source of supply for the item. DLA Land and Maritime maintains an online database of all current sources of supply at <https://landandmaritimeapps.dla.mil/programs/smcr/>.

Vendor item drawing administrative control number <u>1/</u>	Device manufacturer CAGE code	Vendor part number	Top-Side Marking
V62/04619-01XE	01295	SN74ACT373MDWREP	SACT373MEP

1/ The vendor item drawing establishes an administrative control number for identifying the item on the engineering documentation.

CAGE code

01295

Source of supply

Texas Instruments, Inc.
Semiconductor Group
8505 Forest Lane
P.O. Box 660199
Dallas, TX 75243

DLA LAND AND MARITIME COLUMBUS, OHIO	SIZE A	CAGE CODE 16236	DWG NO. V62/04619
		REV C	PAGE 9