

**REVISIONS**

LTR	DESCRIPTION	DATE (YR-MO-DA)	APPROVED
A	Update boilerplate paragraphs to current requirements. - PHN	09-06-24	Thomas M. Hess
B	Update boilerplate to current MIL-PRF-38535 requirements. - PHN	15-09-28	Thomas M. Hess
C	Update boilerplate paragraphs to current VID description requirements. - PHN	22-07-14	Muhammad A. Akbar



**CURRENT DESIGN ACTIVITY CAGE CODE 16236  
HAS CHANGED NAMES TO:  
DLA LAND AND MARITIME  
COLUMBUS, OHIO 43218-3990**

Prepared in accordance with ASME Y14.24

Vendor Item Drawing

Revision Status of Sheets

REV																				
SHEET																				
REV																				
SHEET																				
REV	C	C	C	C	C	C	C	C	C	C										
SHEET	1	2	3	4	5	6	7	8	9	10										

<b>PMIC N/A</b>  Original date of drawing  YY MM DD  03-08-19	<b>PREPARED BY</b> Charles F. Saffle		<b>DEFENSE SUPPLY CENTER, COLUMBUS</b> <b>COLUMBUS, OHIO 43218-3990</b> <a href="https://www.dla.mil/LandandMaritime">https://www.dla.mil/LandandMaritime</a>	
	<b>CHECKED BY</b> Charles F. Saffle		<b>TITLE</b> MICROCIRCUIT, DIGITAL, ADVANCED HIGH SPEED CMOS, 3-LINE TO 8-LINE DECODER/DEMULTIPLEXER WITH TTL COMPATIBLE INPUTS, MONOLITHIC SILICON	
	<b>APPROVED BY</b> Thomas M. Hess			
	<b>SIZE</b> A	<b>CAGE CODE</b> <b>16236</b>	<b>DWG NO.</b> <b>V62/03655</b>	
	<b>REV C</b>		<b>PAGE 1 OF 10</b>	

1. SCOPE

1.1 Scope. This drawing documents the general requirements of a high performance 3-line to 8-line decoder/demultiplexer with TTL compatible inputs microcircuit, with an operating temperature range of -55°C to +125°C.

1.2 Vendor Item Drawing Administrative Control Number. The manufacturer's PIN is the item of identification. The vendor item drawing establishes an administrative control number for identifying the item on the engineering documentation:

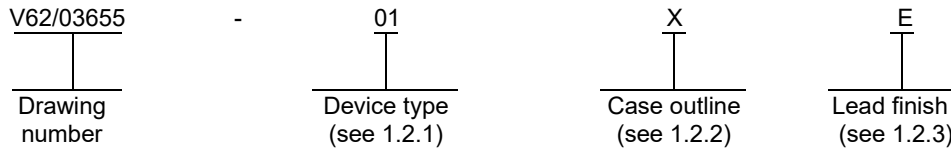

1.2.1 Device type(s).

<u>Device type</u>	<u>Generic</u>	<u>Circuit function</u>
01	74AHCT138-EP	3-line to 8-line decoder/demultiplexer with TTL compatible inputs

1.2.2 Case outlines. The case outlines are as specified herein.

<u>Outline letter</u>	<u>Number of pins</u>	<u>JEDEC PUB 95</u>	<u>Package style</u>
X	16	JEDEC MO-153	Plastic small-outline
Y	16	JEDEC MS-012	Plastic small-outline

1.2.3 Lead finishes. The lead finishes are as specified below or other lead finishes as provided by the device manufacturer:

<u>Finish designator</u>	<u>Material</u>
A	Hot solder dip
B	Tin-lead plate
C	Gold plate
D	Palladium
E	Gold flash palladium
F	Tin-lead alloy
Z	Other

1.3 Absolute maximum ratings. 1/

Supply voltage range ( $V_{CC}$ ) .....	-0.5 V to +7.0 V
Input voltage range ( $V_I$ ) .....	-0.5 V to +7.0 V 2/
Output voltage range ( $V_O$ ) .....	-0.5 V to $V_{CC} + 0.5 V$ 2/
Input clamp current ( $I_{IK}$ ) ( $V_I < 0$ ) .....	-20 mA
Output clamp current ( $I_{OK}$ ) ( $V_O < 0$ or $V_O > V_{CC}$ ) .....	$\pm 20$ mA
Continuous output current ( $I_O$ ) ( $V_O = 0$ to $V_{CC}$ ) .....	$\pm 25$ mA
Continuous current through $V_{CC}$ or GND .....	$\pm 75$ mA
Package thermal impedance ( $\theta_{JA}$ ):	
X package .....	108°C/W 3/
Y package .....	73°C/W 3/
Storage temperature range ( $T_{STG}$ ) .....	-65°C to +150°C

1/ Stresses beyond those listed under "absolute maximum rating" may cause permanent damage to the device. These are stress ratings only, and functional operation of the device at these or any other conditions beyond those indicated under "recommended operating conditions" is not implied. Exposure to absolute-maximum-rated conditions for extended periods may affect device reliability.

2/ The input and output voltage ratings may be exceeded if the input and output current ratings are observed.

3/ The package thermal impedance is calculated in accordance with JEDEC 51-7.

<b>DLA LAND AND MARITIME COLUMBUS, OHIO</b>	<b>SIZE A</b>	<b>CAGE CODE 16236</b>	<b>DWG NO. V62/03655</b>
		REV      C	PAGE 2

1.4 Recommended operating conditions. 4/ 5/

Supply voltage range ( $V_{CC}$ ) .....	4.5 V to 5.5 V
Minimum high level input voltage ( $V_{IH}$ ) .....	2.0 V
Maximum low level input voltage ( $V_{IL}$ ) .....	0.8 V
Input voltage range ( $V_i$ ) .....	0.0 V to 5.5 V
Output voltage range ( $V_o$ ) .....	0.0 V to $V_{CC}$
Maximum high level output current ( $I_{OH}$ ) .....	-8.0 mA
Maximum low level output current ( $I_{OL}$ ) .....	8.0 mA
Maximum input transition rise or fall rate ( $\Delta t/\Delta v$ ) .....	20 ns/V
Operating free-air temperature range ( $T_A$ ) .....	-55°C to +125°C

2. APPLICABLE DOCUMENTS

JEDEC – SOLID STATE TECHNOLOGY ASSOCIATION (JEDEC)

- JEP95 – Registered and Standard Outlines for Semiconductor Devices
- JESD51-7 – High Effective Thermal Conductivity Test Board for Leaded Surface Mount Packages

(Copies of these documents are available online at <https://www.jedec.org>.)

3. REQUIREMENTS

3.1 Marking. Parts shall be permanently and legibly marked with the manufacturer’s part number as shown in 6.3 herein and as follows:

- A. Manufacturer’s name, CAGE code, or logo
- B. Pin 1 identifier
- C. ESDS identification (optional)

3.2 Unit container. The unit container shall be marked with the manufacturer’s part number and with items A and C (if applicable) above.

3.3 Electrical characteristics. The maximum and recommended operating conditions and electrical performance characteristics are as specified in 1.3, 1.4, and table I herein.

3.4 Design, construction, and physical dimension. The design, construction, and physical dimensions are as specified herein.

3.5 Diagrams.

3.5.1 Case outlines. The case outlines shall be as shown in 1.2.2 and figure 1.

3.5.2 Truth table. The truth table shall be as shown in figure 2.

3.5.3 Logic diagram. The logic diagram shall be as shown in figure 3.

3.5.4 Terminal connections. The terminal connections shall be as shown in figure 4.

3.5.5 Timing waveforms and test circuit. The timing waveforms and test circuit shall be as shown in figure 5.

4/ Use of this product beyond the manufacturers design rules or stated parameters is done at the user’s risk. The manufacturer and/or distributor maintain no responsibility or liability for product used beyond the stated limits.

5/ All unused inputs of the device must be held at  $V_{CC}$  or GND to ensure proper device operation.

<b>DLA LAND AND MARITIME COLUMBUS, OHIO</b>	<b>SIZE A</b>	<b>CAGE CODE 16236</b>		<b>DWG NO. V62/03655</b>
		REV	C	PAGE 3

TABLE I. Electrical performance characteristics. 1/

Test	Symbol	Conditions	V <sub>CC</sub>	Temperature, T <sub>A</sub>	Device type	Limits		Unit
						Min	Max	
High level output voltage	V <sub>OH</sub>	I <sub>OH</sub> = -50 μA	4.5 V	25°C, -55°C to 125°C	01	4.4		V
		I <sub>OH</sub> = -8 mA	4.5 V	25°C		3.94		
				-55°C to 125°C		3.80		
Low level output voltage	V <sub>OL</sub>	I <sub>OL</sub> = 50 μA	4.5 V	25°C, -55°C to 125°C	01		0.1	V
		I <sub>OL</sub> = 8 mA	4.5 V	25°C			0.36	
				-55°C to 125°C			0.5	
Input current	I <sub>I</sub>	V <sub>I</sub> = 5.5 V or GND	0.0 V to 5.5 V	25°C	01		±0.1	μA
				-55°C to 125°C			±1.0	
Quiescent supply current	I <sub>CC</sub>	V <sub>I</sub> = V <sub>CC</sub> or GND I <sub>O</sub> = 0 A	5.5 V	25°C	01		4.0	μA
				-55°C to 125°C			40.0	
Quiescent supply current delta, TTL input levels	ΔI <sub>CC</sub> 2/	One input at 3.4 V. Other inputs at V <sub>CC</sub> or GND	5.5 V	25°C	01		1.35	mA
				-55°C to 125°C			1.5	
Input capacitance	C <sub>I</sub>	V <sub>I</sub> = V <sub>CC</sub> or GND	5.0 V	25°C	01		10	pF
Power dissipation capacitance	C <sub>pd</sub>	No load, f = 1 MHz	5.0 V	25°C	01	14	TYP	pF
Propagation delay time, A, B, C to any Y	t <sub>PLH</sub> , t <sub>PHL</sub>	C <sub>L</sub> = 15 pF See figure 5	4.5 V and 5.5 V	25°C	01		10.4	ns
				-55°C to 125°C		1.0	12.0	
		C <sub>L</sub> = 50 pF See figure 5	25°C			11.4		
			-55°C to 125°C	1.0		13.0		
Propagation delay time, $\bar{G}1$ to any Y	t <sub>PLH</sub> , t <sub>PHL</sub>	C <sub>L</sub> = 15 pF See figure 5	4.5 V and 5.5 V	25°C	01		9.1	ns
				-55°C to 125°C		1.0	10.5	
		C <sub>L</sub> = 50 pF See figure 5	25°C			10.1		
			-55°C to 125°C	1.0		11.5		
Propagation delay time, $\bar{G}2A$ or $\bar{G}2B$ to any Y	t <sub>PLH</sub> , t <sub>PHL</sub>	C <sub>L</sub> = 15 pF See figure 5	4.5 V and 5.5 V	25°C	01		9.5	ns
				-55°C to 125°C		1.0	11.0	
		C <sub>L</sub> = 50 pF See figure 5	25°C			10.6		
			-55°C to 125°C	1.0		12.0		

1/ Testing and other quality control techniques are used to the extent deemed necessary to assure product performance over the specified temperature range. Product may not necessarily be tested across the full temperature range and all parameters may not necessarily be tested. In the absence of specific parametric testing, product performance is assured by characterization

2/ This is the increase in supply current for each input at one of the specified TTL voltage levels, rather than 0 V or V<sub>CC</sub>.

3/ Characteristics are for surface-mount packages only.

<b>DLA LAND AND MARITIME COLUMBUS, OHIO</b>	<b>SIZE A</b>	<b>CAGE CODE 16236</b>	<b>DWG NO. V62/03655</b>
		REV      C	PAGE 4

Case X

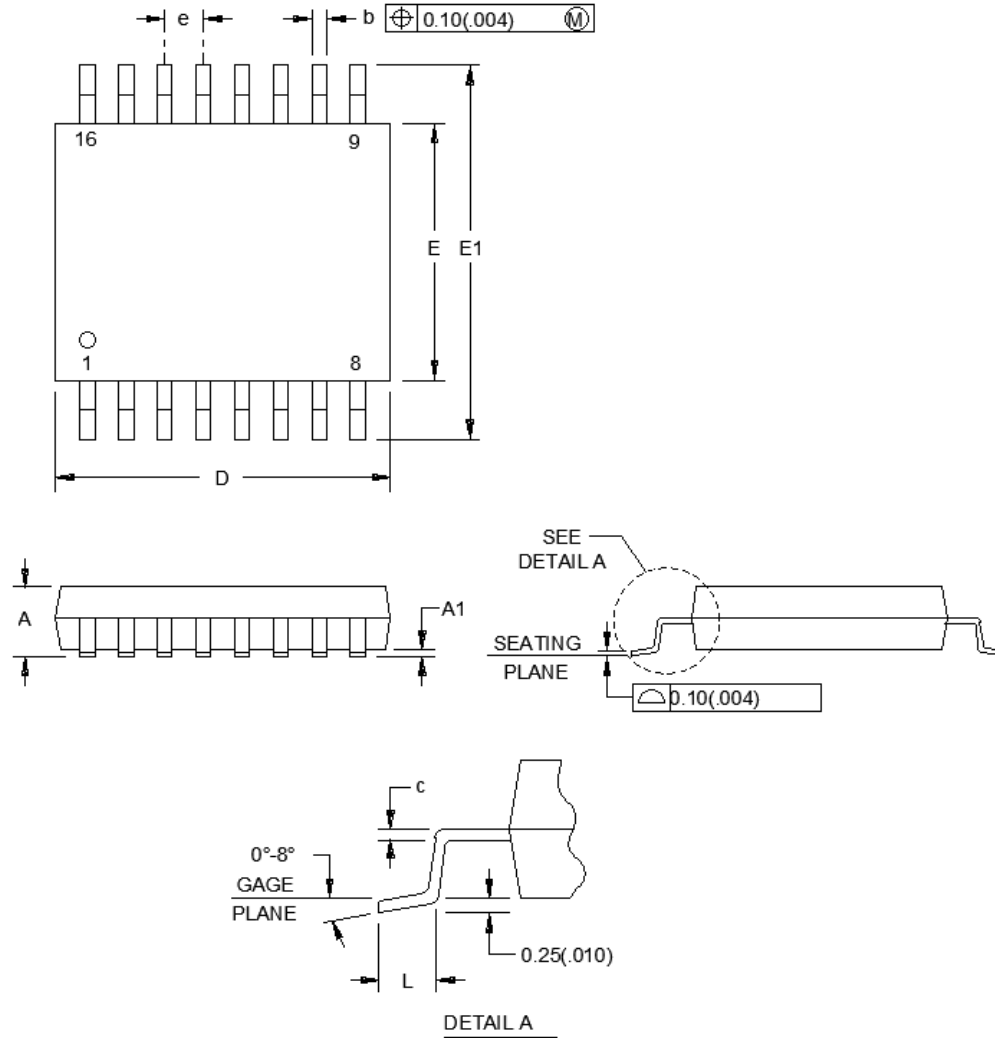

Dimensions									
Symbol	Millimeters		Inches		Symbol	Millimeters		Inches	
	Min	Max	Min	Max		Min	Max	Min	Max
A	---	1.20	---	.047	E	4.30	4.50	.169	.177
A1	0.005	0.15	.002	.006	E1	6.200	6.60	.244	.260
b	0.19	0.30	.007	.012	e	0.65	NOM	.026	NOM
c	0.15	NOM	.006	NOM	L	0.50	0.75	.020	.030
D	4.90	5.10	.193	.201					

NOTES:

1. This drawing is subject to change without notice.
2. Body dimensions do not include mold flash or protrusion not to exceed 0.15 mm.
3. Falls within JEDEC MO-153.
4. All linear dimensions are shown in millimeters (inches). Inches equivalents are given for general information only.

FIGURE 1. Case outlines.

DLA LAND AND MARITIME COLUMBUS, OHIO	SIZE A	CAGE CODE 16236	DWG NO. V62/03655
		REV C	PAGE 5

Case Y

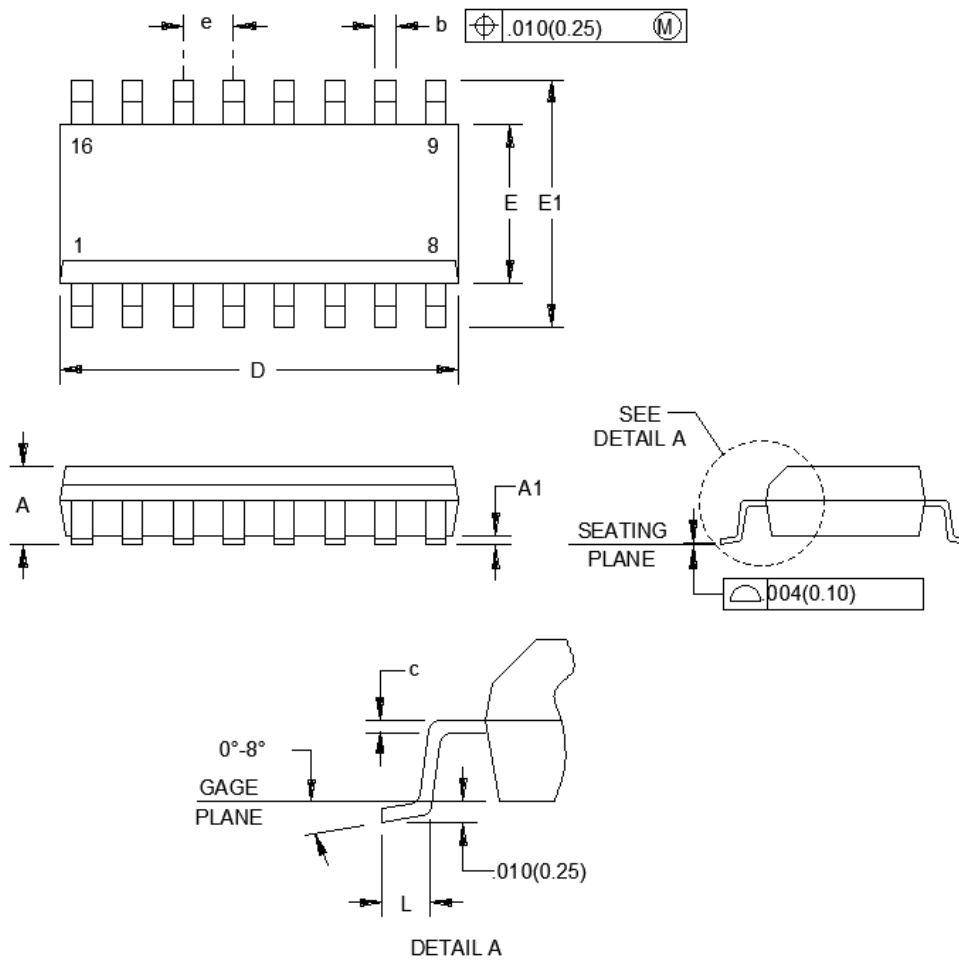

Dimensions									
Symbol	Millimeters		Inches		Symbol	Millimeters		Inches	
	Min	Max	Min	Max		Min	Max	Min	Max
A	---	1.75	---	.069	E	3.81	4.00	.150	.157
A1	0.10	0.25	.004	.010	E1	5.80	6.20	.228	.244
b	0.35	0.51	.014	.020	e	1.27	NOM	.050	NOM
c	0.20	NOM	.008	NOM	L	0.40	1.12	.016	.044
D	9.80	10.00	.386	.394					

NOTES:

1. This drawing is subject to change without notice.
2. Body dimensions do not include mold flash or protrusion not to exceed 0.006 inches (0.15 mm).
3. Falls within JEDEC MS-012.
4. All linear dimensions are shown in inches (millimeters). Metric equivalents are given for general information only.

FIGURE 1. Case outlines - Continued.

DLA LAND AND MARITIME COLUMBUS, OHIO	SIZE A	CAGE CODE 16236	DWG NO. V62/03655
		REV C	PAGE 6

Enable inputs			Select inputs			Output							
G1	$\overline{G2A}$	$\overline{G2B}$	C	B	A	Y0	Y1	Y2	Y3	Y4	Y5	Y6	Y7
X	H	X	X	X	X	H	H	H	H	H	H	H	H
X	X	H	X	X	X	H	H	H	H	H	H	H	H
L	X	X	X	X	X	H	H	H	H	H	H	H	H
H	L	L	L	L	L	L	H	H	H	H	H	H	H
H	L	L	L	L	H	H	L	H	H	H	H	H	H
H	L	L	L	H	L	H	H	L	H	H	H	H	H
H	L	L	L	H	H	H	H	H	L	H	H	H	H
H	L	L	H	L	L	H	H	H	H	L	H	H	H
H	L	L	H	L	H	H	H	H	H	H	L	H	H
H	L	L	H	H	L	H	H	H	H	H	H	L	H
H	L	L	H	H	H	H	H	H	H	H	H	H	L

X = Immaterial

FIGURE 2. Truth table.

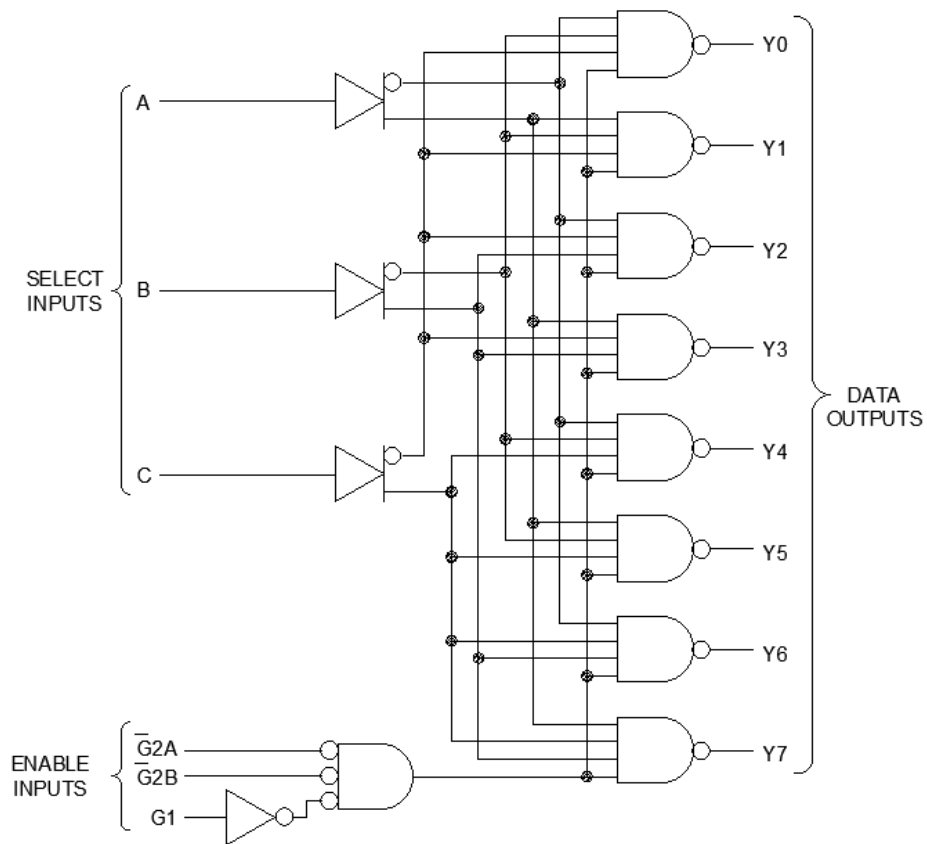

FIGURE 3. Logic diagram.

<b>DLA LAND AND MARITIME COLUMBUS, OHIO</b>	<b>SIZE A</b>	<b>CAGE CODE 16236</b>	<b>DWG NO. V62/03655</b>
		REV      C	PAGE 7

Device type 01  
Case outlines: X and Y

Terminal number	Terminal symbol	Terminal number	Terminal symbol
1	A	9	Y6
2	B	10	Y5
3	C	11	Y4
4	$\bar{G}2A$	12	Y3
5	$\bar{G}2B$	13	Y2
6	G1	14	Y1
7	Y7	15	Y0
8	GND	16	V <sub>cc</sub>

FIGURE 2. Terminal connections.

<b>DLA LAND AND MARITIME COLUMBUS, OHIO</b>	<b>SIZE A</b>	<b>CAGE CODE 16236</b>		<b>DWG NO. V62/03655</b>
		REV	C	PAGE 8



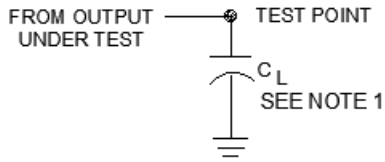

LOAD CIRCUIT FOR TOTEM-POLE OUTPUTS

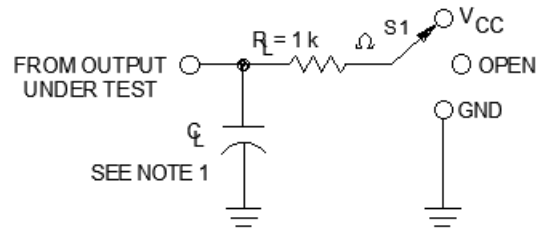

LOAD CIRCUIT FOR 3-STATE AND OPEN-DRAIN OUTPUTS

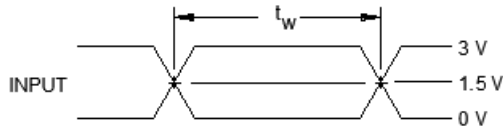

VOLTAGE WAVEFORMS PULSE DURATION

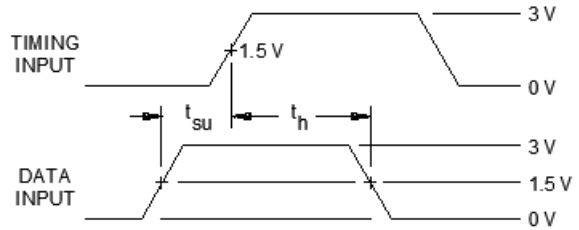

VOLTAGE WAVEFORMS SETUP AND HOLD TIMES

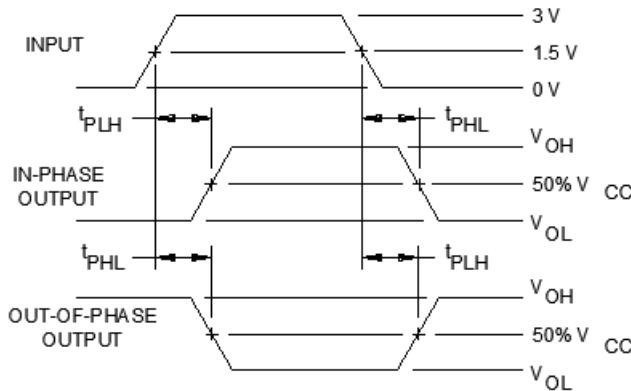

VOLTAGE WAVEFORMS PROPAGATION DELAY TIMES INVERTING AND NONINVERTING OUTPUTS

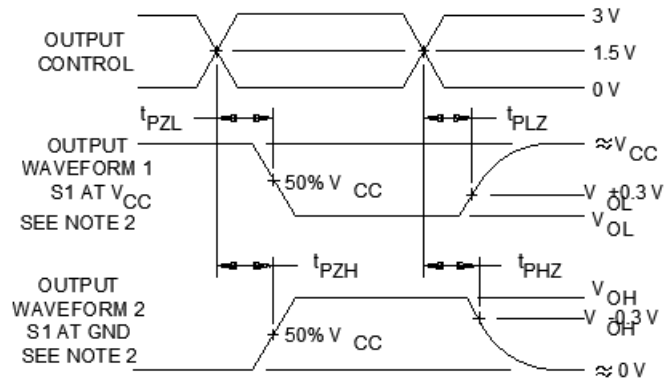

VOLTAGE WAVEFORMS ENABLE AND DISABLE TIMES LOW AND HIGH-LEVEL ENABLING

Notes:

1.  $C_L$  includes probe and jig capacitance.
2. Waveform 1 is for an output with internal conditions such that the output is low except when disabled by the output control. Waveform 2 is for an output with internal conditions such that the output is high except when disabled by the output control.
3. All input pulses are supplied by generators having the following characteristics:  $PRR \leq 1 \text{ MHz}$ ,  $Z_O = 50\Omega$ ,  $t_r \leq 3 \text{ ns}$ ,  $t_f \leq 3 \text{ ns}$ .
4. The outputs are measured one at a time with one input transition per measurement.
5. For 3-state and Open Drain outputs tests:
 

$t_{PLH}/t_{PHL}$	S1 = Open
$t_{PLZ}/t_{PZL}$	S1 = $V_{CC}$
$t_{PHZ}/t_{PZH}$	S1 = GND
Open Drain	S1 = $V_{CC}$

FIGURE 5. Timing waveforms and test circuit.

<b>DLA LAND AND MARITIME COLUMBUS, OHIO</b>	<b>SIZE A</b>	<b>CAGE CODE 16236</b>	<b>DWG NO. V62/03655</b>
		REV      C	PAGE 9

4. VERIFICATION

4.1 Product assurance requirements. The manufacturer is responsible for performing all inspection and test requirements as indicated in their internal documentation. Such procedures should include proper handling of electrostatic sensitive devices, classification, packaging, and labeling of moisture sensitive devices, as applicable.

5. PREPARATION FOR DELIVERY

5.1 Packaging. Preservation, packaging, labeling, and marking shall be in accordance with the manufacturer’s standard commercial practices for electrostatic discharge sensitive devices.

6. NOTES

6.1 ESDS. Devices are electrostatic discharge sensitive and are classified as ESDS class 1 minimum.

6.2 Configuration control. The data contained herein is based on the salient characteristics of the device manufacturer’s data book. The device manufacturer reserves the right to make changes without notice. This drawing will be modified as changes are provided.

6.3 Suggested source(s) of supply. Identification of the suggested source(s) of supply herein is not to be construed as a guarantee of present or continued availability as a source of supply for the item. DLA Land and Maritime maintains an online database of all current sources of supply at <https://landandmaritimeapps.dla.mil/programs/smcr/>.

Vendor item drawing administrative control number <u>1/</u>	Device manufacturer CAGE code	Vendor part number	Top-Side Marking
V62/03655-01XE	01295	SN74AHCT138MPWREP	AT138EP
V62/03655-01YE	01295	SN74AHCT138MDREP	AHCT138MEP

1/ The vendor item drawing establishes an administrative control number for identifying the item on the engineering documentation.

CAGE code

01295

Source of supply

Texas Instruments, Inc.  
Semiconductor Group  
8505 Forest Lane  
P.O. Box 660199  
Dallas, TX 75243

<b>DLA LAND AND MARITIME COLUMBUS, OHIO</b>	<b>SIZE A</b>	<b>CAGE CODE 16236</b>	<b>DWG NO. V62/03655</b>
		REV      C	PAGE 10