

REVISIONS			
LTR	DESCRIPTION	DATE (YR-MO-DA)	APPROVED
A	Make change to 1.5 and add subgroup 4 to device class V and group E section as specified in table IIA. - ro	99-07-30	R. MONNIN
B	Drawing updated to reflect current requirements. - gt	03-02-20	R. MONNIN
C	Add enhanced low dose rate effects (ELDRS) paragraph to 1.5 and table I. - rrp	05-10-28	R. MONNIN
D	Add the words "condition A" after method 1019 as specified under 4.4.4.1. Delete Accelerated aging test, paragraph 4.4.4.1.1. - ro	07-06-12	R. HEBER
E	Make change to the V_{IO} test subgroups by deleting 4,5,6 and substituting 1,2,3 under Table I. Make change to the $\Delta V_{IO}/\Delta t$ test subgroups by deleting 5,6 and substituting 2,3 under Table I. Make change to the all CMRR, PSRR, and A_{VS} test subgroups by deleting 4,5,6 and substituting 1,2,3 under Table I. Delete subgroups 5 and 6 from Tabel IIA. Add subgroups 5 and 6 to paragraph 4.4.1b. Add two footnotes under Table IIB. Delete paragraph 4.4.4.2. - ro	11-03-28	C. SAFFLE



REV																				
SHEET																				
REV																				
SHEET																				

REV STATUS	REV	E	E	E	E	E	E	E	E	E	E	E	E	E	E		
OF SHEETS	SHEET	1	2	3	4	5	6	7	8	9	10	11	12				

PMIC N/A	PREPARED BY RICK OFFICER	DLA LAND AND MARITIME COLUMBUS, OHIO 43218-3990 http://www.dsccl.dla.mil															
STANDARD MICROCIRCUIT DRAWING THIS DRAWING IS AVAILABLE FOR USE BY ALL DEPARTMENTS AND AGENCIES OF THE DEPARTMENT OF DEFENSE AMSC N/A	CHECKED BY RAJESH PITHADIA																
	APPROVED BY RAYMOND MONNIN	MICROCIRCUIT, LINEAR, RADIATION HARDENED, ULTRA-LOW OFFSET VOLTAGE OPERATIONAL AMPLIFIER, MONOLITHIC SILICON															
	DRAWING APPROVAL DATE 98-10-08																
	REVISION LEVEL E	SIZE A	CAGE CODE 67268	5962-98639													
		SHEET		1 OF 12													

1.3 Absolute maximum ratings. 1/

Supply voltage (V _S)	±22.0 V dc
Input voltage (V _{IN})	±22.0 V dc <u>2/</u>
Differential input voltage	±30 V dc
Internal power dissipation (P _D)	500 mW
Output short circuit duration	Indefinite
Lead temperature (soldering, 10 seconds)	+300°C
Junction temperature (T _J)	+150°C
Storage temperature range	-65°C to +150°C
Thermal resistance, junction-to-case (θ _{JC})	See MIL-STD-1835
Thermal resistance, junction-to-ambient (θ _{JA}):	
Cases G and H	+150°C/W
Case P	+119°C/W
Case 2	+110°C/W

1.4 Recommended operating conditions.

Supply voltage range (V _S)	±4.5 V dc to ±20 V dc
Ambient operating temperature range (T _A)	-55°C to +125°C

1.5 Radiation features.

Maximum total dose available (dose rate = 50 – 300 rads (Si)/s)	100 krad <u>3/</u>
-----------------------------------------------------------------------	--------------------

1/ Stresses above the absolute maximum rating may cause permanent damage to the device. Extended operation at the maximum levels may degrade performance and affect reliability.
2/ For supply voltage less than ±22 V, the absolute maximum input voltage is equal to the supply voltage.
3/ These parts may be dose rate sensitive in a space environment and may demonstrate enhanced low dose rate effects. Radiation end point limits for the noted parameters are guaranteed only for the conditions specified in MIL-STD-883, method 1019, condition A.

STANDARD MICROCIRCUIT DRAWING DLA LAND AND MARITIME COLUMBUS, OHIO 43218-3990	SIZE A		5962-98639
		REVISION LEVEL E	SHEET 3

2. APPLICABLE DOCUMENTS

2.1 Government specification, standards, and handbooks. The following specification, standards, and handbooks form a part of this drawing to the extent specified herein. Unless otherwise specified, the issues of these documents are those cited in the solicitation or contract.

DEPARTMENT OF DEFENSE SPECIFICATION

MIL-PRF-38535 - Integrated Circuits, Manufacturing, General Specification for.

DEPARTMENT OF DEFENSE STANDARDS

MIL-STD-883 - Test Method Standard Microcircuits.
 MIL-STD-1835 - Interface Standard Electronic Component Case Outlines.

DEPARTMENT OF DEFENSE HANDBOOKS

MIL-HDBK-103 - List of Standard Microcircuit Drawings.
 MIL-HDBK-780 - Standard Microcircuit Drawings.

(Copies of these documents are available online at <https://assist.daps.dla.mil/quicksearch/> or from the Standardization Document Order Desk, 700 Robbins Avenue, Building 4D, Philadelphia, PA 19111-5094.)

2.2 Order of precedence. In the event of a conflict between the text of this drawing and the references cited herein, the text of this drawing takes precedence. Nothing in this document, however, supersedes applicable laws and regulations unless a specific exemption has been obtained.

3. REQUIREMENTS

3.1 Item requirements. The individual item requirements for device classes Q and V shall be in accordance with MIL-PRF-38535 and as specified herein or as modified in the device manufacturer's Quality Management (QM) plan. The modification in the QM plan shall not affect the form, fit, or function as described herein. The individual item requirements for device class M shall be in accordance with MIL-PRF-38535, appendix A for non-JAN class level B devices and as specified herein.

3.2 Design, construction, and physical dimensions. The design, construction, and physical dimensions shall be as specified in MIL-PRF-38535 and herein for device classes Q and V or MIL-PRF-38535, appendix A and herein for device class M.

3.2.1 Case outlines. The case outlines shall be in accordance with 1.2.4 herein.

3.2.2 Terminal connections. The terminal connections shall be as specified on figure 1.

3.2.3 Radiation exposure circuit. The radiation exposure circuit shall be as specified on figure 2.

3.3 Electrical performance characteristics and postirradiation parameter limits. Unless otherwise specified herein, the electrical performance characteristics and postirradiation parameter limits are as specified in table I and shall apply over the full ambient operating temperature range.

3.4 Electrical test requirements. The electrical test requirements shall be the subgroups specified in table IIA. The electrical tests for each subgroup are defined in table I.

3.5 Marking. The part shall be marked with the PIN listed in 1.2 herein. In addition, the manufacturer's PIN may also be marked. For packages where marking of the entire SMD PIN is not feasible due to space limitations, the manufacturer has the option of not marking the "5962-" on the device. For RHA product using this option, the RHA designator shall still be marked. Marking for device classes Q and V shall be in accordance with MIL-PRF-38535. Marking for device class M shall be in accordance with MIL-PRF-38535, appendix A.

STANDARD MICROCIRCUIT DRAWING DLA LAND AND MARITIME COLUMBUS, OHIO 43218-3990	SIZE A		5962-98639
		REVISION LEVEL E	SHEET 4

TABLE I. Electrical performance characteristics.

Test	Symbol	Conditions <u>1/ 2/</u> -55°C ≤ T _A ≤ +125°C unless otherwise specified	Group A subgroups	Device type	Limits		Unit
					Min	Max	
Input offset voltage	V _{IO}	<u>3/</u> M,D,P,L,R <u>4/</u>	1	01	-25	+25	μV
			2,3		-60	+60	
			1		-400	+400	
Input offset voltage temperature sensitivity	ΔV _{IO} / Δt	<u>5/</u>	2,3	01	-0.6	+0.6	μV/°C
Input bias current	+I _B		1	01	-2	+2	nA
			2,3		-4	+4	
	-I _B		1		-2	+2	
			2,3		-4	+4	
I _B	M,D,P,L,R <u>4/</u>	1	-125	+125			
Input offset current	I _{IO}		1	01	-2	+2	nA
			2,3		-4	+4	
			M,D,P,L,R <u>4/</u>		1	-25	
Power supply rejection ratio <u>5/</u>	+PSRR	+V _S = +20 V to +5 V, -V _S = -15 V	1	01	-10	10	μV/V
			2,3		-20	20	
	-PSRR	+V _S = +15 V, -V _S = -20 V to -5 V	1		-10	10	
			2,3		-20	20	
	PSRR	V _S = ±4.5 V to ±20 V	1		-10	10	
			2,3		-20	20	
Common mode <u>5/</u> rejection ratio	CMRR	V _{CM} = ±13 V	1	01	110		dB
			2,3		106		
Adjustment short circuit current <u>5/</u>	+V _{IO} ADJ	V _{CM} = 0 V	1	01	0.5		mV
	-V _{IO} ADJ					-0.5	
Output short circuit current	+I _{OS}	t ≤ 25 ms <u>5/ 6/</u>	1,2	01	-65		mA
			3		-70		
	-I _{OS}		1,2			65	
			3			70	

See footnotes at end of table.

STANDARD MICROCIRCUIT DRAWING DLA LAND AND MARITIME COLUMBUS, OHIO 43218-3990	SIZE A		5962-98639
		REVISION LEVEL E	SHEET 5

TABLE I. Electrical performance characteristics - Continued.

Test	Symbol	Conditions <u>1/ 2/</u> -55°C ≤ T _A ≤ +125°C unless otherwise specified	Group A subgroups	Device type	Limits		Unit
					Min	Max	
Supply current	I _S	V _{CM} = 0 V	1	01		4	mA
			2,3			5	
			M,D,P,L,R <u>4/</u>		1		
Output voltage swing <u>5/</u> (minimum)	V _{OP}	R _L = 1 kΩ	1,2,3	01	-10	10	V
		R _L = 2 kΩ			-12	12	
Open loop voltage gain (single ended)	+A _{VS}	V _{OUT} = 0 V to +10 V, R _L = 2 kΩ	1	01	300		V / mV
			2,3		200		
	-A _{VS}	V _{OUT} = 0 V to -10 V, R _L = 2 kΩ	1		300		
			2,3		200		
A _{VS}	V _{OUT} = ±10 V, R _L = 2 kΩ M,D,P,L,R <u>4/</u>	1	100				
Slew rate <u>5/</u>	+SR, -SR	V _{IN} = ±5 V, A _V = 1	4	01	.08		V / μs
Input noise voltage <u>5/</u> density	E _n	f _O = 10 Hz	4	01		18	nV / √Hz
		f _O = 100 Hz				14	
		f _O = 1 kHz				12	
Low frequency input <u>5/</u> noise voltage	E _{npp}	f _O = 0.1 Hz to 10 Hz	4	01		0.6	μV _{PP}

1/ ±V_S = ±15 V and V_{CM} = 0 V.

2/ These parts may be dose rate sensitive in a space environment and may demonstrate enhanced low dose rate effects. Radiation end point limits for the noted parameters are guaranteed only for the conditions specified in MIL-STD-883, method 1019, condition A.

3/ Due to the inherent warm-up drift of device type 01, testing shall occur no sooner than five minutes after application of power.

4/ Devices supplied to this drawing have been characterized through all levels M, D, P, L, and R of irradiation. However, this device is only tested at the "R" level. Pre and Post irradiation values are identical unless otherwise specified in table I. When performing post irradiation electrical measurements for any RHA level, T_A = +25°C.

5/ This parameter is not tested to post irradiation.

6/ Continuous short circuit limits are considerably less than the indicated test limits since maximum power dissipation cannot be exceeded.

STANDARD MICROCIRCUIT DRAWING DLA LAND AND MARITIME COLUMBUS, OHIO 43218-3990	SIZE A		5962-98639
		REVISION LEVEL E	SHEET 6

Device type	01		
Case outlines	G and P	H	2
Terminal number	Terminal symbol		
1	V _{IO} TRIM	NC	NC
2	-INPUT	V _{IO} TRIM	V _{IO} TRIM
3	+INPUT	-INPUT	NC
4	-V _S	+INPUT	NC
5	NC	-V _S	-INPUT
6	OUTPUT	NC	NC
7	+V _S	OUTPUT	+INPUT
8	V _{IO} TRIM	+V _S	NC
9	---	V _{IO} TRIM	NC
10	---	NC	-V _S
11	---	---	NC
12	---	---	NC
13	---	---	NC
14	---	---	NC
15	---	---	OUTPUT
16	---	---	NC
17	---	---	+V _S
18	---	---	NC
19	---	---	NC
20	---	---	V _{IO} TRIM

NC = No connection

FIGURE 1. Terminal connections.

STANDARD MICROCIRCUIT DRAWING DLA LAND AND MARITIME COLUMBUS, OHIO 43218-3990	SIZE A		5962-98639
		REVISION LEVEL E	SHEET 7

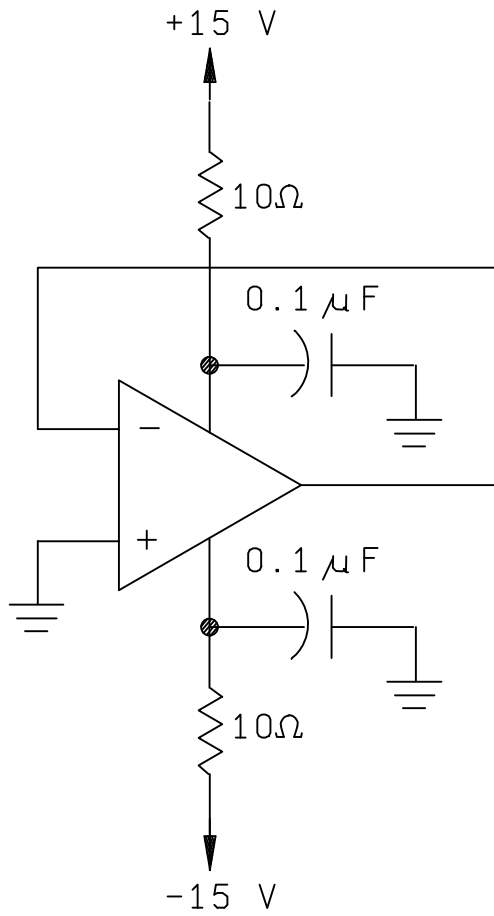

FIGURE 2. Radiation exposure circuit.

**STANDARD
MICROCIRCUIT DRAWING**
DLA LAND AND MARITIME
COLUMBUS, OHIO 43218-3990

SIZE
A

5962-98639

REVISION LEVEL
E

SHEET
8

3.5.1 Certification/compliance mark. The certification mark for device classes Q and V shall be a "QML" or "Q" as required in MIL-PRF-38535. The compliance mark for device class M shall be a "C" as required in MIL-PRF-38535, appendix A.

3.6 Certificate of compliance. For device classes Q and V, a certificate of compliance shall be required from a QML-38535 listed manufacturer in order to supply to the requirements of this drawing (see 6.6.1 herein). For device class M, a certificate of compliance shall be required from a manufacturer in order to be listed as an approved source of supply in MIL-HDBK-103 (see 6.6.2 herein). The certificate of compliance submitted to DLA Land and Maritime-VA prior to listing as an approved source of supply for this drawing shall affirm that the manufacturer's product meets, for device classes Q and V, the requirements of MIL-PRF-38535 and herein or for device class M, the requirements of MIL-PRF-38535, appendix A and herein.

3.7 Certificate of conformance. A certificate of conformance as required for device classes Q and V in MIL-PRF-38535 or for device class M in MIL-PRF-38535, appendix A shall be provided with each lot of microcircuits delivered to this drawing.

3.8 Notification of change for device class M. For device class M, notification to DLA Land and Maritime -VA of change of product (see 6.2 herein) involving devices acquired to this drawing is required for any change that affects this drawing.

3.9 Verification and review for device class M. For device class M, DLA Land and Maritime, DLA Land and Maritime's agent, and the acquiring activity retain the option to review the manufacturer's facility and applicable required documentation. Offshore documentation shall be made available onshore at the option of the reviewer.

3.10 Microcircuit group assignment for device class M. Device class M devices covered by this drawing shall be in microcircuit group number 49 (see MIL-PRF-38535, appendix A).

4. VERIFICATION

4.1 Sampling and inspection. For device classes Q and V, sampling and inspection procedures shall be in accordance with MIL-PRF-38535 or as modified in the device manufacturer's Quality Management (QM) plan. The modification in the QM plan shall not affect the form, fit, or function as described herein. For device class M, sampling and inspection procedures shall be in accordance with MIL-PRF-38535, appendix A.

4.2 Screening. For device classes Q and V, screening shall be in accordance with MIL-PRF-38535, and shall be conducted on all devices prior to qualification and technology conformance inspection. For device class M, screening shall be in accordance with method 5004 of MIL-STD-883, and shall be conducted on all devices prior to quality conformance inspection.

4.2.1 Additional criteria for device class M.

a. Burn-in test, method 1015 of MIL-STD-883.

(1) Test condition A, B, C, or D. The test circuit shall be maintained by the manufacturer under document revision level control and shall be made available to the preparing or acquiring activity upon request. The test circuit shall specify the inputs, outputs, biases, and power dissipation, as applicable, in accordance with the intent specified in method 1015 of MIL-STD-883.

(2) $T_A = +125^\circ\text{C}$, minimum.

b. Interim and final electrical test parameters shall be as specified in table IIA herein.

STANDARD MICROCIRCUIT DRAWING DLA LAND AND MARITIME COLUMBUS, OHIO 43218-3990	SIZE A		5962-98639
		REVISION LEVEL E	SHEET 9

TABLE IIA. Electrical test requirements.

Test requirements	Subgroups (in accordance with MIL-STD-883, method 5005, table I)	Subgroups (in accordance with MIL-PRF-38535, table III)	
	Device class M	Device class Q	Device class V
Interim electrical parameters (see 4.2)	1	1	1
Final electrical parameters (see 4.2)	1,2,3,4 <u>1/</u>	1,2,3,4 <u>1/</u>	1,2,3,4 <u>1/ 2/</u>
Group A test requirements (see 4.4)	1,2,3,4	1,2,3,4	1,2,3,4
Group C end-point electrical parameters (see 4.4)	1	1	1 <u>2/</u>
Group D end-point electrical parameters (see 4.4)	1	1	1
Group E end-point electrical parameters (see 4.4)	1	1	1

1/ PDA applies to subgroup 1.

2/ Delta limits as specified in table IIB shall be required where specified, and the delta limits shall be completed with reference to the zero hour electrical parameters (see table I).

TABLE IIB. Burn-in and operating life test delta parameters. T_A = +25°C. 1/ 2/

Parameter	Device type	Limits		Delta		Units
		Min	Max	Min	Max	
V _{IO}	01	-135	+135	-75	+75	μV
+I _B	01	-5	+5	-1	+1	nA
-I _B	01	-5	+5	-1	+1	nA

1/ Deltas are performed at room temperature.

2/ 240 hour burn-in and 1,000 hour operating group C life test.

4.2.2 Additional criteria for device classes Q and V.

- a. The burn-in test duration, test condition and test temperature, or approved alternatives shall be as specified in the device manufacturer's QM plan in accordance with MIL-PRF-38535. The burn-in test circuit shall be maintained under document revision level control of the device manufacturer's Technology Review Board (TRB) in accordance with MIL-PRF-38535 and shall be made available to the acquiring or preparing activity upon request. The test circuit shall specify the inputs, outputs, biases, and power dissipation, as applicable, in accordance with the intent specified in method 1015 of MIL-STD-883.
- b. Interim and final electrical test parameters shall be as specified in table IIA herein.
- c. Additional screening for device class V beyond the requirements of device class Q shall be as specified in MIL-PRF-38535, appendix B.

STANDARD MICROCIRCUIT DRAWING DLA LAND AND MARITIME COLUMBUS, OHIO 43218-3990	SIZE A		5962-98639
		REVISION LEVEL E	SHEET 10

4.3 Qualification inspection for device classes Q and V. Qualification inspection for device classes Q and V shall be in accordance with MIL-PRF-38535. Inspections to be performed shall be those specified in MIL-PRF-38535 and herein for groups A, B, C, D, and E inspections (see 4.4.1 through 4.4.4).

4.4 Conformance inspection. Technology conformance inspection for classes Q and V shall be in accordance with MIL-PRF-38535 including groups A, B, C, D, and E inspections and as specified herein. Quality conformance inspection for device class M shall be in accordance with MIL-PRF-38535, appendix A and as specified herein. Inspections to be performed for device class M shall be those specified in method 5005 of MIL-STD-883 and herein for groups A, B, C, D, and E inspections (see 4.4.1 through 4.4.4).

4.4.1 Group A inspection.

- a. Tests shall be as specified in table IIA herein.
- b. Subgroups 5, 6, 7, 8, 9, 10, and 11 in table I, method 5005 of MIL-STD-883 shall be omitted.

4.4.2 Group C inspection. The group C inspection end-point electrical parameters shall be as specified in table IIA herein.

4.4.2.1 Additional criteria for device class M. Steady-state life test conditions, method 1005 of MIL-STD-883:

- a. Test condition A, B, C, or D. The test circuit shall be maintained by the manufacturer under document revision level control and shall be made available to the preparing or acquiring activity upon request. The test circuit shall specify the inputs, outputs, biases, and power dissipation, as applicable, in accordance with the intent specified in method 1005 of MIL-STD-883.
- b. $T_A = +125^\circ\text{C}$, minimum.
- c. Test duration: 1,000 hours, except as permitted by method 1005 of MIL-STD-883.

4.4.2.2 Additional criteria for device classes Q and V. The steady-state life test duration, test condition and test temperature, or approved alternatives shall be as specified in the device manufacturer's QM plan in accordance with MIL-PRF-38535. The test circuit shall be maintained under document revision level control by the device manufacturer's TRB in accordance with MIL-PRF-38535 and shall be made available to the acquiring or preparing activity upon request. The test circuit shall specify the inputs, outputs, biases, and power dissipation, as applicable, in accordance with the intent specified in method 1005 of MIL-STD-883.

4.4.3 Group D inspection. The group D inspection end-point electrical parameters shall be as specified in table IIA herein.

4.4.4 Group E inspection. Group E inspection is required only for parts intended to be marked as radiation hardness assured (see 3.5 herein).

- a. End-point electrical parameters shall be as specified in table IIA herein.
- b. For device classes Q and V, the devices or test vehicle shall be subjected to radiation hardness assured tests as specified in MIL-PRF-38535 for the RHA level being tested. For device class M, the devices shall be subjected to radiation hardness assured tests as specified in MIL-PRF-38535, appendix A for the RHA level being tested. All device classes must meet the postirradiation end-point electrical parameter limits as defined in table I at $T_A = +25^\circ\text{C} \pm 5^\circ\text{C}$, after exposure, to the subgroups specified in table IIA herein.

4.4.4.1 Total dose irradiation testing. Total dose irradiation testing shall be performed in accordance with MIL-STD-883 method 1019, condition A and as specified herein.

5. PACKAGING

5.1 Packaging requirements. The requirements for packaging shall be in accordance with MIL-PRF-38535 for device classes Q and V or MIL-PRF-38535, appendix A for device class M.

STANDARD MICROCIRCUIT DRAWING DLA LAND AND MARITIME COLUMBUS, OHIO 43218-3990	SIZE A		5962-98639
		REVISION LEVEL E	SHEET 11

6. NOTES

6.1 Intended use. Microcircuits conforming to this drawing are intended for use for Government microcircuit applications (original equipment), design applications, and logistics purposes.

6.1.1 Replaceability. Microcircuits covered by this drawing will replace the same generic device covered by a contractor prepared specification or drawing.

6.1.2 Substitutability. Device class Q devices will replace device class M devices.

6.2 Configuration control of SMD's. All proposed changes to existing SMD's will be coordinated with the users of record for the individual documents. This coordination will be accomplished using DD Form 1692, Engineering Change Proposal.

6.3 Record of users. Military and industrial users should inform DLA Land and Maritime when a system application requires configuration control and which SMD's are applicable to that system. DLA Land and Maritime will maintain a record of users and this list will be used for coordination and distribution of changes to the drawings. Users of drawings covering microelectronic devices (FSC 5962) should contact DLA Land and Maritime -VA, telephone (614) 692-0544.

6.4 Comments. Comments on this drawing should be directed to DLA Land and Maritime -VA, Columbus, Ohio 43218-3990, or telephone (614) 692-0540.

6.5 Abbreviations, symbols, and definitions. The abbreviations, symbols, and definitions used herein are defined in MIL-PRF-38535 and MIL-HDBK-1331.

6.6 Sources of supply.

6.6.1 Sources of supply for device classes Q and V. Sources of supply for device classes Q and V are listed in QML-38535. The vendors listed in QML-38535 have submitted a certificate of compliance (see 3.6 herein) to DLA Land and Maritime -VA and have agreed to this drawing.

6.6.2 Approved sources of supply for device class M. Approved sources of supply for class M are listed in MIL-HDBK-103. The vendors listed in MIL-HDBK-103 have agreed to this drawing and a certificate of compliance (see 3.6 herein) has been submitted to and accepted by DLA Land and Maritime -VA.

STANDARD MICROCIRCUIT DRAWING DLA LAND AND MARITIME COLUMBUS, OHIO 43218-3990	SIZE A		5962-98639
		REVISION LEVEL E	SHEET 12

STANDARD MICROCIRCUIT DRAWING BULLETIN

DATE: 11-03-28

Approved sources of supply for SMD 5962-98639 are listed below for immediate acquisition information only and shall be added to MIL-HDBK-103 and QML-38535 during the next revision. MIL-HDBK-103 and QML-38535 will be revised to include the addition or deletion of sources. The vendors listed below have agreed to this drawing and a certificate of compliance has been submitted to and accepted by DLA Land and Maritime -VA. This information bulletin is superseded by the next dated revision of MIL-HDBK-103 and QML-38535. DLA Land and Maritime maintains an online database of all current sources of supply at <http://www.dscc.dla.mil/Programs/Smcr/>.

Standard microcircuit drawing PIN <u>1/</u>	Vendor CAGE number	Vendor similar PIN <u>2/</u>
5962R9863901VGA	24355	OP07AJ/QMLR
5962R9863901VHA	24355	OP07AL/QMLR
5962R9863901VPA	24355	OP07AZ/QMLR
5962R9863901V2A	<u>3/</u>	OP07ARC/QMLR

1/ The lead finish shown for each PIN representing a hermetic package is the most readily available from the manufacturer listed for that part. If the desired lead finish is not listed contact the vendor to determine its availability.

2/ Caution. Do not use this number for item acquisition. Items acquired to this number may not satisfy the performance requirements of this drawing.

3/ Not available from an approved source of supply.

Vendor CAGE
number

24355

Vendor name
and address

Analog Devices
Route 1 Industrial Park
P.O. Box 9106
Norwood, MA 02062
Point of contact: 7910 Triad Center Drive
Greensboro, NC 27409-9605

The information contained herein is disseminated for convenience only and the Government assumes no liability whatsoever for any inaccuracies in the information bulletin.