

REVISIONS

LTR	DESCRIPTION	DATE (YR-MO-DA)	APPROVED
A	Drawing updated to reflect current requirements. -rrp	04-06-29	R. Monnin
B	Redrawn. Update paragraphs to MIL-PRF-38535 requirements. - drw	16-08-08	Charles F. Saffle
C	Add paragraph 3.2.4 Timing waveforms. Update document paragraphs to current MIL-PRF-38535 requirements. - ro	22-10-20	James R. Eschmeyer



Revision Status of Sheets

REV																																																						
SHEET																																																						
REV	C	C	C	C	C	C	C	C	C	C	C	C																																										
SHEET	1	2	3	4	5	6	7	8	9	10	11	12																																										

PMIC N/A		PREPARED BY Dan Wonnell		DLA LAND AND MARITIME COLUMBUS, OHIO 43218-3990 https://www.dla.mil/LandandMaritime	
STANDARD MICROCIRCUIT DRAWING THIS DRAWING IS AVAILABLE FOR USE BY ALL DEPARTMENTS AND AGENCIES OF THE DEPARTMENT OF DEFENSE		CHECKED BY Raymond Monnin			
		APPROVED BY Raymond Monnin			
		DRAWING APPROVAL DATE 98-12-09			
		MICROCIRCUIT, LINEAR, LINE RECEIVER, QUAD, DIFFERENTIAL, 3 VOLT, MONOLITHIC SILICON			
AMSC N/A		REVISION LEVEL C		SIZE A	CAGE CODE 67268
					5962-98585

1. SCOPE

1.1 Scope. This drawing documents two product assurance class levels consisting of high reliability (device class Q) and space application (device class V). A choice of case outlines and lead finishes are available and are reflected in the Part or Identifying Number (PIN). When available, a choice of Radiation Hardness Assurance (RHA) levels is reflected in the PIN.

1.2 PIN. The PIN is as shown in the following example:

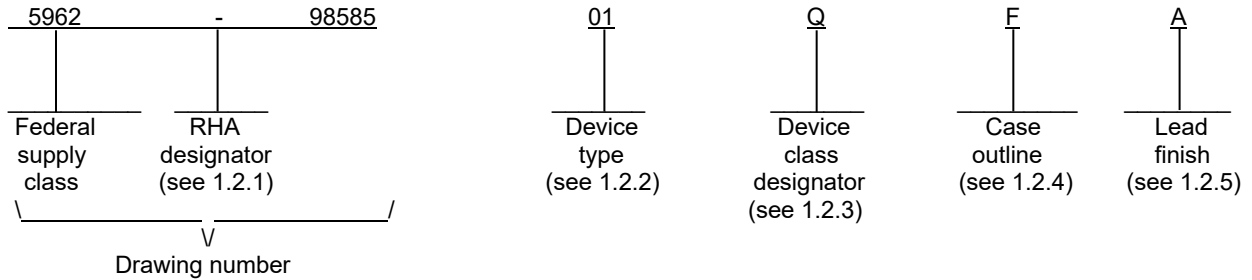

1.2.1 RHA designator. Device classes Q and V RHA marked devices meet the MIL-PRF-38535 specified RHA levels and are marked with the appropriate RHA designator. A dash (-) indicates a non-RHA device.

1.2.2 Device type(s). The device type(s) identify the circuit function as follows:

<u>Device type</u>	<u>Generic number</u>	<u>Circuit function</u>
01	DS26LV32	Quad differential line driver, 3 volt

1.2.3 Device class designator. The device class designator is a single letter identifying the product assurance level as follows:

<u>Device class</u>	<u>Device requirements documentation</u>
Q or V	Certification and qualification to MIL-PRF-38535

1.2.4 Case outline(s). The case outline(s) are as designated in MIL-STD-1835 and as follows:

<u>Outline letter</u>	<u>Descriptive designator</u>	<u>Terminals</u>	<u>Package style</u>
F	GDFP2-F16 or CDFP3-F16	16	Flatpack

1.2.5 Lead finish. The lead finish is as specified in MIL-PRF-38535 for device classes Q and V.

STANDARD MICROCIRCUIT DRAWING DLA LAND AND MARITIME COLUMBUS, OHIO 43218-3990	SIZE A		5962-98585
		REVISION LEVEL C	SHEET 2

1.3 Absolute maximum ratings. 1/

Supply voltage (VCC)	7.0 V
Common mode range (VCM)	±14 V
Differential input voltage (VDIFF)	±14 V
Enable input voltage (VIN)	-0.5 V to VCC +0.5 V
Storage temperature range	-65°C to +150°C
Lead temperature (soldering, 4 seconds)	260°C
Maximum power dissipation, +25°C 2/	1087 mW
Junction temperature (TJ)	175°C
Thermal resistance, junction-to-ambient (θJA)	138°C/W
Thermal resistance, junction-to-case (θJC)	13.5°C/W

1.4 Recommended operating conditions.

Supply voltage (VCC)	3.0 V to 3.6 V
Ambient operating temperature range (TA)	-55°C to +125°C

2. APPLICABLE DOCUMENTS

2.1 Government specification, standards, and handbooks. The following specification, standards, and handbooks form a part of this drawing to the extent specified herein. Unless otherwise specified, the issues of these documents are those cited in the solicitation or contract.

DEPARTMENT OF DEFENSE SPECIFICATION

MIL-PRF-38535 - Integrated Circuits, Manufacturing, General Specification for.

DEPARTMENT OF DEFENSE STANDARDS

MIL-STD-883 - Test Method Standard Microcircuits.
 MIL-STD-1835 - Interface Standard Electronic Component Case Outlines.

DEPARTMENT OF DEFENSE HANDBOOKS

MIL-HDBK-103 - List of Standard Microcircuit Drawings.
 MIL-HDBK-780 - Standard Microcircuit Drawings.

(Copies of these documents are available online at <https://quicksearch.dla.mil/>.)

2.2 Order of precedence. In the event of a conflict between the text of this drawing and the references cited herein, the text of this drawing takes precedence. Nothing in this document, however, supersedes applicable laws and regulations unless a specific exemption has been obtained.

1/ Stresses above the absolute maximum rating may cause permanent damage to the device. Extended operation at the maximum levels may degrade performance and affect reliability.
 2/ Derate linearly 7.3 mW/°C above +25°C.

STANDARD MICROCIRCUIT DRAWING DLA LAND AND MARITIME COLUMBUS, OHIO 43218-3990	SIZE A		5962-98585
		REVISION LEVEL C	SHEET 3

3. REQUIREMENTS

3.1 Item requirements. The individual item requirements for device classes Q and V shall be in accordance with MIL-PRF-38535 as specified herein, or as modified in the device manufacturer's Quality Management (QM) plan. The modification in the QM plan shall not affect the form, fit, or function as described herein.

3.2 Design, construction, and physical dimensions. The design, construction, and physical dimensions shall be as specified in MIL-PRF-38535 and herein for device classes Q and V.

3.2.1 Case outline. The case outline shall be in accordance with 1.2.4 herein.

3.2.2 Terminal connections. The terminal connections shall be as specified on figure 1.

3.2.3 Truth table. The truth table shall be as specified on figure 2.

3.2.4 Timing waveforms. The timing waveforms shall be as specified on figure 3.

3.3 Electrical performance characteristics and postirradiation parameter limits. Unless otherwise specified herein, the electrical performance characteristics and postirradiation parameter limits are as specified in table I and shall apply over the full ambient operating temperature range.

3.4 Electrical test requirements. The electrical test requirements shall be the subgroups specified in table II. The electrical tests for each subgroup are defined in table I.

3.5 Marking. The part shall be marked with the PIN listed in 1.2 herein. In addition, the manufacturer's PIN may also be marked. For packages where marking of the entire SMD PIN number is not feasible due to space limitations, the manufacturer has the option of not marking the "5962-" on the device. For RHA product using this option, the RHA designator shall still be marked. Marking for device classes Q and V shall be in accordance with MIL-PRF-38535.

3.5.1 Certification/compliance mark. The certification mark for device classes Q and V shall be a "QML" or "Q" as required in MIL-PRF-38535.

3.6 Certificate of compliance. For device classes Q and V, a certificate of compliance shall be required from a QML-38535 listed manufacturer in order to supply to the requirements of this drawing (see 6.6.1 herein). The certificate of compliance submitted to DLA Land and Maritime-VA prior to listing as an approved source of supply for this drawing shall affirm that the manufacturer's product meets, for device classes Q and V, the requirements of MIL-PRF-38535 and herein.

3.7 Certificate of conformance. A certificate of conformance as required for device classes Q and V in MIL-PRF-38535 in MIL-PRF-38535, appendix A shall be provided with each lot of microcircuits delivered to this drawing.

STANDARD MICROCIRCUIT DRAWING DLA LAND AND MARITIME COLUMBUS, OHIO 43218-3990	SIZE A		5962-98585
		REVISION LEVEL C	SHEET 4

TABLE I. Electrical performance characteristics.

Test	Symbol	Conditions -55°C ≤ TA ≤ +125°C VCC = 3.0 V / 3.6 V, CL = 50 pF unless otherwise specified	Group A subgroups	Device type	Limits		Unit
					Min	Max	
Minimum enable high level input voltage	VIH	1/	1, 2, 3	All	2.0		V
Maximum enable low level input voltage	VIL	1/	1, 2, 3	All		0.8	V
Minimum differential input voltage	VTH	VOUT = VOH or VOL, -0.5 V < VCM < +5.5 V	1, 2, 3	All	-200	+200	mV
Input resistance	RIN	VCC = 3.6 V, -0.5 V < VCM < +5.5 V, "one input AC Gnd"	1, 2, 3	All	5		kΩ
Logical "1" output voltage	VOH	VCC = 3.0 V, VDIFF = +1 V, IOUT = -6.0 mA	1, 2, 3	All	2.4		V
Logical "0" output voltage	VOL	VCC = 3.0 V, VDIFF = -1 V, IOUT = 6.0 mA	1, 2, 3	All		0.5	V
Input current	IIN	VCC = 3.6 V, VIN = +5.5 V, other input = Gnd	1, 2, 3	All	0	+1.8	mA
		VCC = 3.6 V, VIN = -0.5 V, other input = Gnd	1, 2, 3	All	0	-1.8	mA
		VCC = 0 V, VIN = +5.5 V, other input = Gnd	1, 2, 3	All	0	+1.8	mA
		VCC = 0 V, VIN = -0.5 V, other input = Gnd	1, 2, 3	All	0	-1.8	mA
Maximum enable input current	IEN	VCC = 3.6 V, VIN = VCC or Gnd	1, 2, 3	All		±1.0	μA
Quiescent power supply current	ICC	VCC = 3.6 V, no load, enable, ENABLE = VCC or Gnd, -0.5 V < VCM < +5.5 V	1, 2, 3	All		20	mA
Tri-state output leakage current	IOZ	VOUT = VCC or Gnd, ENABLE = VIL, ENABLE = VIH, VCC = 3.6 V	1, 2, 3	All		±50	μA
Output short circuit current	IOS	VDIFF = +1 V, VOUT = 0 V 2/	1, 2, 3	All	-10	-70	mA
Functional test	FT	See 4.4.1c	7, 8	All			

See footnotes at end of table.

STANDARD MICROCIRCUIT DRAWING DLA LAND AND MARITIME COLUMBUS, OHIO 43218-3990	SIZE A		5962-98585
		REVISION LEVEL C	SHEET 5

TABLE I. Electrical performance characteristics - continued.

Test	Symbol	Conditions -55°C ≤ TA ≤ +125°C VCC = 3.0 V / 3.6 V, CL = 50 pF unless otherwise specified	Group A subgroups	Device type	Limits		Unit
					Min	Max	
Input to output propagation delay	tPLH	VCM = 1.5 V, see figure 3 <u>3/</u>	9, 10, 11	All	6	45	ns
Input to output propagation delay	tPHL	VCM = 1.5 V, see figure 3 <u>3/</u>	9, 10, 11	All	6	45	ns
Skew tPHLD-tPLHD (same channel)	tSK1		9, 10, 11	All		6	ns
Pin to pin skew (same device)	tSK2		9, 10, 11	All		6	ns
Output enable time	tPZH	2 kΩ to Gnd, see figure 3 <u>4/</u>	9, 10, 11	All		50	ns
	tPZL	2 kΩ to VCC, see figure 3 <u>4/</u>	9, 10, 11	All		50	ns
Output disable time	tPHZ	2 kΩ to Gnd, see figure 3 <u>4/</u>	9, 10, 11	All		50	ns
	tPLZ	2 kΩ to VCC, see figure 3 <u>4/</u>	9, 10, 11	All		50	ns

1/ Parameter tested go-no-go only.

2/ Short one output at a time.

3/ Generator waveform is specified as follows: f = 1 MHz, duty cycle = 50%, ZO = 50 Ω, tr = tf ≤ 6 ns.
Receiver inputs = 1 V to 2 V with measure points equal to 1.5 V on the inputs to ½ VCC on the output.

4/ Generator waveform is specified as follows: f = 1 MHz, duty cycle = 50%, ZO = 50 Ω, tr = tf ≤ 6 ns.
Enable/ ENABLE inputs 0 V to 3 V with measure points equal to 1.5 V on the inputs, to ½ VCC on the outputs for ZL and ZH, and (VOL +0.3 V) for LZ, and (VOH -0.3 V) for Hz.

**STANDARD
MICROCIRCUIT DRAWING**
DLA LAND AND MARITIME
COLUMBUS, OHIO 43218-3990

SIZE
A

5962-98585

REVISION LEVEL
C

SHEET **6**

Device type	01
Case outline	F
Terminal number	Terminal symbol
1	INPUT 1-
2	INPUT 1+
3	OUTPUT 1
4	ENABLE
5	OUTPUT 2
6	INPUT 2+
7	INPUT 2-
8	GND
9	INPUT 3-
10	INPUT 3+
11	OUTPUT 3
12	$\overline{\text{ENABLE}}$
13	OUTPUT 4
14	INPUT 4+
15	INPUT 4-
16	VCC

FIGURE 1. Terminal connections.

ENABLE	$\overline{\text{ENABLE}}$	INPUT+ - INPUT-	OUTPUT -
L	H	X	Z
All other combinations of enable inputs		$V_{ID} \geq +0.2 \text{ V}$	H
		$V_{ID} \leq -0.2 \text{ V}$	L
		OPEN	H

FIGURE 2. Truth table.

STANDARD MICROCIRCUIT DRAWING DLA LAND AND MARITIME COLUMBUS, OHIO 43218-3990	SIZE A		5962-98585
		REVISION LEVEL C	SHEET 7

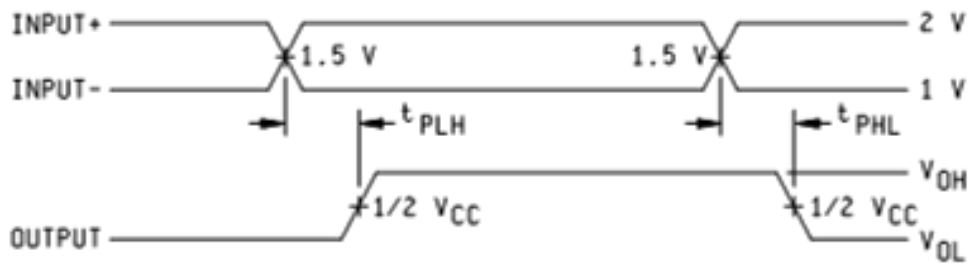
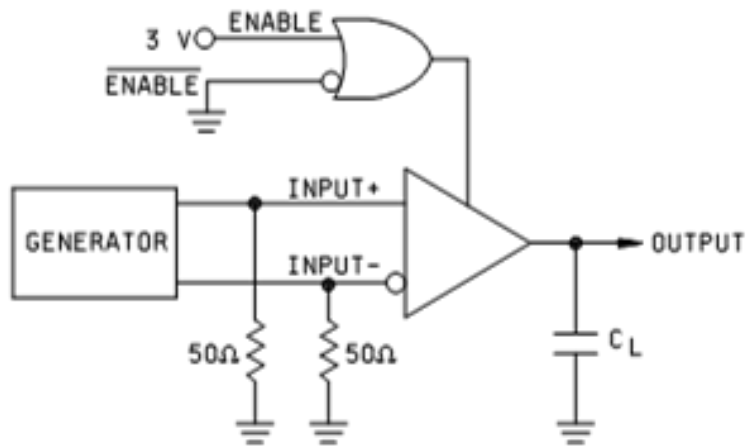

FIGURE 3. Timing waveforms.

**STANDARD
MICROCIRCUIT DRAWING**
DLA LAND AND MARITIME
COLUMBUS, OHIO 43218-3990

SIZE
A

5962-98585

REVISION LEVEL
C

SHEET **8**

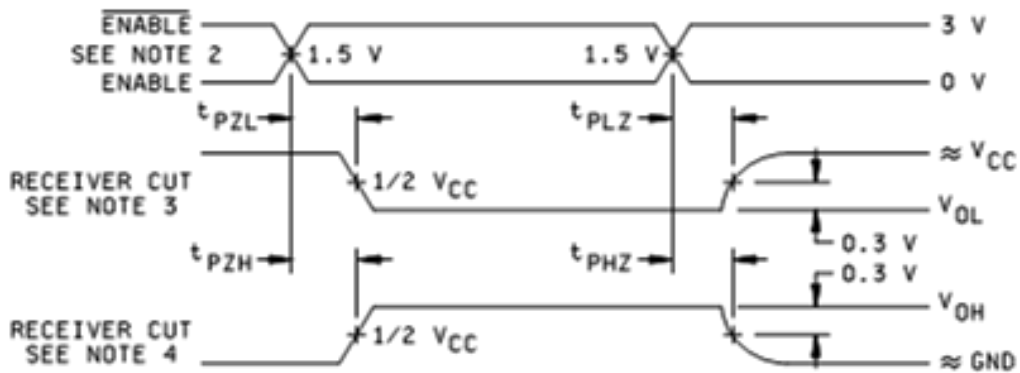
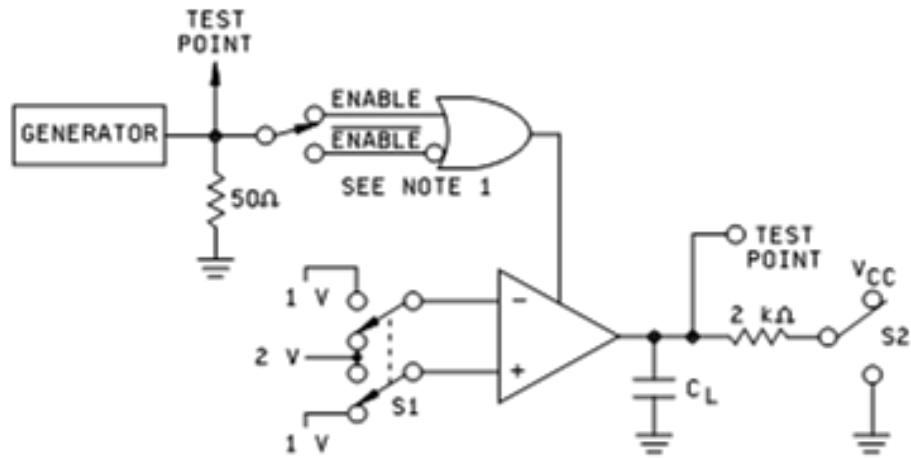

Notes:

1. When ENABLE is switched, $\overline{\text{ENABLE}} = 3 \text{ V}$. When $\overline{\text{ENABLE}}$ is switched, $\text{ENABLE} = \text{GND}$.
2. When ENABLE is active, $\overline{\text{ENABLE}} = 3 \text{ V}$. When $\overline{\text{ENABLE}}$ is active, $\text{ENABLE} = \text{GND}$.
3. $S1- = 2 \text{ V}$, $S1+ = 1 \text{ V}$, $S2 = V_{CC}$.
4. $S1- = 1 \text{ V}$, $S1+ = 2 \text{ V}$, $S2 = \text{GND}$.

FIGURE 3. Timing waveforms - continued.

**STANDARD
MICROCIRCUIT DRAWING**

DLA LAND AND MARITIME
COLUMBUS, OHIO 43218-3990

SIZE
A

REVISION LEVEL
C

5962-98585

SHEET **9**

4. VERIFICATION

4.1 Sampling and inspection. For device classes Q and V, sampling and inspection procedures shall be in accordance with MIL-PRF-38535 or as modified in the device manufacturer's Quality Management (QM) plan. The modification in the QM plan shall not affect the form, fit, or function as described herein.

4.2 Screening. For device classes Q and V, screening shall be in accordance with MIL-PRF-38535, and shall be conducted on all devices prior to qualification and technology conformance inspection.

4.2.1 Additional criteria for device classes Q and V.

- a. The burn-in test duration, test condition and test temperature, or approved alternatives shall be as specified in the device manufacturer's QM plan in accordance with MIL-PRF-38535. The burn-in test circuit shall be maintained under document revision level control of the device manufacturer's Technology Review Board (TRB) in accordance with MIL-PRF-38535 and shall be made available to the acquiring or preparing activity upon request. The test circuit shall specify the inputs, outputs, biases, and power dissipation, as applicable, in accordance with the intent specified in method 1015 of MIL-STD-883.
- b. Interim and final electrical test parameters shall be as specified in table II herein.
- c. Additional screening for device class V beyond the requirements of device class Q shall be as specified in MIL-PRF-38535, appendix B.

4.3 Qualification inspection for device classes Q and V. Qualification inspection for device classes Q and V shall be in accordance with MIL-PRF-38535. Inspections to be performed shall be those specified in MIL-PRF-38535 and herein for groups A, B, C, D, and E inspections (see 4.4.1 through 4.4.4).

4.4 Conformance inspection. Technology conformance inspection for classes Q and V shall be in accordance with MIL-PRF-38535 including groups A, B, C, D, and E inspections, and as specified herein.

4.4.1 Group A inspection.

- a. Tests shall be as specified in table II herein.
- b. Subgroups 4, 5, and 6 in table I, method 5005 of MIL-STD-883 shall be omitted.
- c. For device classes Q and V, subgroups 7 and 8 shall include verifying the functionality of the device.

4.4.2 Group C inspection. The group C inspection end-point electrical parameters shall be as specified in table II herein.

4.4.2.1 Additional criteria for device classes Q and V. The steady-state life test duration, test condition and test temperature, or approved alternatives shall be as specified in the device manufacturer's QM plan in accordance with MIL-PRF-38535. The test circuit shall be maintained under document revision level control by the device manufacturer's TRB in accordance with MIL-PRF-38535 and shall be made available to the acquiring or preparing activity upon request. The test circuit shall specify the inputs, outputs, biases, and power dissipation, as applicable, in accordance with the intent specified in method 1005 of MIL-STD-883.

4.4.3 Group D inspection. The group D inspection end-point electrical parameters shall be as specified in table II herein.

STANDARD MICROCIRCUIT DRAWING DLA LAND AND MARITIME COLUMBUS, OHIO 43218-3990	SIZE A		5962-98585
		REVISION LEVEL C	SHEET 10

TABLE II. Electrical test requirements.

Test requirements	Subgroups (in accordance with MIL-PRF-38535, table III)	
	Device class Q	Device class V
Interim electrical parameters (see 4.2)	1	1
Final electrical parameters (see 4.2)	1, 2, 3, <u>1/</u> 7, 8, 9, 10, 11	1, 2, 3, <u>1/</u> 7, 8, 9, 10, 11
Group A test requirements (see 4.4)	1, 2, 3, 7, 8, 9, 10, 11	1, 2, 3, 7, 8, 9, 10, 11
Group C end-point electrical parameters (see 4.4)	1, 2, 3	1, 2, 3
Group D end-point electrical parameters (see 4.4)	1, 2, 3	1, 2, 3
Group E end-point electrical parameters (see 4.4)	---	---

1/ PDA applies to subgroup 1.

4.4.4 Group E inspection. Group E inspection is required only for parts intended to be marked as radiation hardness assured (see 3.5 herein).

- a. End-point electrical parameters shall be as specified in table II herein.
- b. For device classes Q and V, the devices or test vehicle shall be subjected to radiation hardness assured tests as specified in MIL-PRF-38535 for the RHA level being tested. All device classes must meet the postirradiation end-point electrical parameter limits as defined in table I at TA = +25°C ±5°C, after exposure, to the subgroups specified in table II herein.

5. PACKAGING

5.1 Packaging requirements. The requirements for packaging shall be in accordance with MIL-PRF-38535 for device classes Q and V.

6. NOTES

6.1 Intended use. Microcircuits conforming to this drawing are intended for use for Government microcircuit applications (original equipment), design applications, and logistics purposes.

6.1.1 Replaceability. Microcircuits covered by this drawing will replace the same generic device covered by a contractor prepared specification or drawing.

6.2 Configuration control of SMD's. All proposed changes to existing SMD's will be coordinated with the users of record for the individual documents. This coordination will be accomplished using DD Form 1692, Engineering Change Proposal, or email communication.

STANDARD MICROCIRCUIT DRAWING DLA LAND AND MARITIME COLUMBUS, OHIO 43218-3990	SIZE A		5962-98585
		REVISION LEVEL C	SHEET 11

6.3 Record of users. Military and industrial users should inform DLA Land and Maritime when a system application requires configuration control and which SMD's are applicable to that system. DLA Land and Maritime will maintain a record of users and this list will be used for coordination and distribution of changes to the drawings. Users of drawings covering microelectronic devices (FSC 5962) should contact DLA Land and Maritime-VA, telephone (614) 692-8108.

6.4 Comments. Comments on this drawing should be directed to DLA Land and Maritime-VA, Columbus, Ohio 43218-3990, or telephone (614) 692-0591.

6.5 Abbreviations, symbols, and definitions. The abbreviations, symbols, and definitions used herein are defined in MIL-PRF-38535 and MIL-HDBK-1331.

6.6 Sources of supply.

6.6.1 Sources of supply for device classes Q and V. Sources of supply for device classes Q and V are listed in MIL-HDBK-103 and QML-38535. The vendors listed in MIL-HDBK-103 and QML-38535 have submitted a certificate of compliance (see 3.6 herein) to DLA Land and Maritime-VA and have agreed to this drawing.

STANDARD MICROCIRCUIT DRAWING DLA LAND AND MARITIME COLUMBUS, OHIO 43218-3990	SIZE A		5962-98585
		REVISION LEVEL C	SHEET 12

STANDARD MICROCIRCUIT DRAWING BULLETIN

DATE: 22-10-20

Approved sources of supply for SMD 5962-98585 are listed below for immediate acquisition information only and shall be added to MIL-HDBK-103 and QML-38535 during the next revision. MIL-HDBK-103 and QML-38535 will be revised to include the addition or deletion of sources. The vendors listed below have agreed to this drawing and a certificate of compliance has been submitted to and accepted by DLA Land and Maritime-VA. This information bulletin is superseded by the next dated revision of MIL-HDBK-103 and QML-38535. DLA Land and Maritime maintains an online database of all current sources of supply at <https://landandmaritimeapps.dla.mil/programs/smcr/>.

Standard microcircuit drawing PIN <u>1/</u>	Vendor CAGE number	Vendor similar PIN <u>2/</u>
5962-9858501QFA	01295	DS26LV32AW-QML

1/ The lead finish shown for each PIN representing a hermetic package is the most readily available from the manufacturer listed for that part. If the desired lead finish is not listed contact the vendor to determine its availability.

2/ Caution. Do not use this number for item acquisition. Items acquired to this number may not satisfy the performance requirements of this drawing.

Vendor CAGE number

01295

Vendor name and address

Texas Instruments, Inc.
Semiconductor Group
8505 Forest Ln.
PO Box 660199
Dallas, TX 75243

The information contained herein is disseminated for convenience only and the Government assumes no liability whatsoever for any inaccuracies in the information bulletin.