

REVISIONS			
LTR	DESCRIPTION	DATE (YR-MO-DA)	APPROVED
A	Update boilerplate to MIL-PRF-38535 requirements. Editorial changes throughout. - LTG	02-12-23	Thomas M. Hess
B	Add device Class V requirements as follows: Add footnote 3/ on table IIA, Add Burn-in and operating life test delta limits parameters on table IIB. Update boilerplate to current MIL-PRF-38535 requirements. - MAA	08-10-06	Thomas M. Hess
C	Update boilerplate paragraphs to the current MIL-PRF-38535 requirements. Delete class M requirement throughout. - LTG	15-02-26	Thomas M. Hess
D	Update boilerplate to MIL-PRF-38535 requirements. - DRH	21-10-05	Muhammad A. Akbar



REV																					
SHEET																					
REV	D	D	D	D																	
SHEET	15	16	17	18																	
REV STATUS OF SHEETS	REV			D	D	D	D	D	D	D	D	D	D	D	D	D	D	D	D		
	SHEET			1	2	3	4	5	6	7	8	9	10	11	12	13	14				
PMIC N/A	PREPARED BY Joseph A. Kerby						<b>DLA LAND AND MARITIME</b> <b>COLUMBUS, OHIO 43218-3990</b> <a href="https://www.dla.mil/LandandMaritime">https://www.dla.mil/LandandMaritime</a>  MICROCIRCUIT, DIGITAL, LOW VOLTAGE CMOS, OCTAL BUS TRANSCEIVER AND REGISTER WITH THREE-STATE OUTPUTS, TTL COMPATIBLE INPUTS, MONOLITHIC SILICON														
<b>STANDARD MICROCIRCUIT DRAWING</b>  THIS DRAWING IS AVAILABLE FOR USE BY ALL DEPARTMENTS AND AGENCIES OF THE DEPARTMENT OF DEFENSE  AMSC N/A	CHECKED BY Charles F. Saffle, Jr.																				
	APPROVED BY Monica L. Poelking																				
	DRAWING APPROVAL DATE 97-12-04																				
	REVISION LEVEL D																				
						SIZE A	CAGE CODE <b>67268</b>	<b>5962-97626</b>													
						SHEET		1 OF 18													

1. SCOPE

1.1 Scope. This drawing documents two product assurance class levels consisting of high reliability (device class Q) and space application (device class V). A choice of case outlines and lead finishes are available and are reflected in the Part or Identifying Number (PIN). When available, a choice of Radiation Hardness Assurance (RHA) levels is reflected in the PIN.

1.2 PIN. The PIN is as shown in the following example:

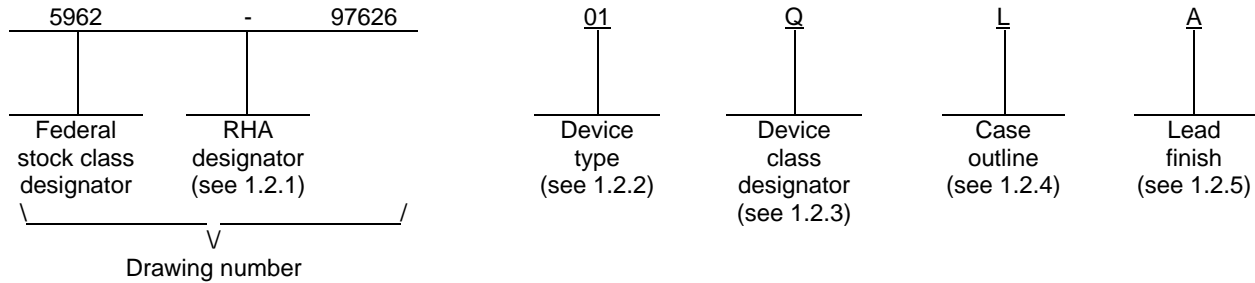

1.2.1 RHA designator. Device classes Q and V RHA marked devices meet the MIL-PRF-38535 specified RHA levels and are marked with the appropriate RHA designator. A dash (-) indicates a non-RHA device.

1.2.2 Device type(s). The device type(s) identify the circuit function as follows:

<u>Device type</u>	<u>Generic number</u>	<u>Circuit function</u>
01	54LVC646A	Octal Bus transceiver and register with three-state outputs

1.2.3 Device class designator. The device class designator is a single letter identifying the product assurance level as follows:

<u>Device class</u>	<u>Device requirements documentation</u>
Q or V	Certification and qualification to MIL-PRF-38535

1.2.4 Case outline(s). The case outline(s) are as designated in MIL-STD-1835 and as follows:

<u>Outline letter</u>	<u>Descriptive designator</u>	<u>Terminals</u>	<u>Package style</u>
L	GDIP3-T24 or CDIP4-T24	24	Dual-in-line
K	GDFP2-F24 or CDFP3-F24	24	Flat pack
3	CQCC1-N28	28	Square leadless chip carrier

1.2.5 Lead finish. The lead finish is as specified in MIL-PRF-38535 for device classes Q and V.

<b>STANDARD MICROCIRCUIT DRAWING</b> DLA LAND AND MARITIME COLUMBUS, OHIO 43218-3990	SIZE <b>A</b>		<b>5962-97626</b>
		REVISION LEVEL D	SHEET 2

1.3 Absolute maximum ratings. 1/ 2/ 3/

Supply voltage range ( $V_{CC}$ ).....	-0.5 V dc to +6.5 V dc
DC input voltage range ( $V_{IN}$ ):	
Except I/O ports .....	-0.5 V dc to +6.5 V dc 4/
I/O ports .....	-0.5 V dc to $V_{CC} + 0.5$ V dc 4/ 5/
DC output voltage range ( $V_{OUT}$ ) (high impedance or power-off state).....	-0.5 V dc to +6.5 V dc 4/
DC output voltage range ( $V_{OUT}$ ) (high or low state).....	-0.5 V dc to $V_{CC} + 0.5$ V dc 4/ 5/
DC input clamp current ( $I_{IK}$ ) ( $V_{IN} < 0.0$ V).....	-50 mA
DC output clamp current ( $I_{OK}$ ) ( $V_{OUT} < 0.0$ V or $V_{OUT} > V_{CC}$ ) .....	$\pm 50$ mA
Continuous output current ( $I_{OUT}$ ) ( $V_{OUT} = 0$ to $V_{CC}$ ).....	$\pm 50$ mA 5/
Continuous current through $V_{CC}$ or GND.....	$\pm 100$ mA
Maximum power dissipation at $T_A = +55^\circ\text{C}$ (in still air) .....	500 mW 6/
Storage temperature range ( $T_{STG}$ ).....	$-65^\circ\text{C}$ to $+150^\circ\text{C}$
Lead temperature (soldering, 10 seconds) .....	$+300^\circ\text{C}$
Thermal resistance, junction-to-case ( $\theta_{JC}$ ) .....	See MIL-STD-1835
Junction temperature ( $T_J$ ) .....	$+150^\circ\text{C}$

1.4 Recommended operating conditions. 2/ 3/ 7/

Supply operating voltage range ( $V_{CC}$ ).....	+2.0 V dc to +3.6 V dc
Supply operating minimum voltage ( $V_{CC}$ ) (Data retention only) .....	+1.5 V dc
Minimum high level input voltage ( $V_{IH}$ ) ( $V_{CC} = 2.7$ V to 3.6 V).....	+2.0 V
Maximum low level input voltage ( $V_{IL}$ ) ( $V_{CC} = 2.7$ V to 3.6 V).....	+0.8 V
Input voltage range ( $V_{IN}$ ).....	0.0 V to +5.5 V dc
Output voltage range ( $V_{OUT}$ ):	
High or low state .....	0.0 V to $V_{CC}$
High impedance state.....	0.0 V to 5.5 V dc
Maximum high level output current ( $I_{OH}$ ):	
$V_{CC} = 2.7$ V .....	-12 mA
$V_{CC} = 3.0$ V .....	-24 mA
Maximum low level output current ( $I_{OL}$ ):	
$V_{CC} = 2.7$ V .....	+12 mA
$V_{CC} = 3.0$ V .....	+24 mA
Maximum input rise and fall rate ( $\Delta t/\Delta V$ ).....	10 ns/V
Case operating temperature range ( $T_C$ ).....	$-55^\circ\text{C}$ to $+125^\circ\text{C}$

- 1/ Stresses above the absolute maximum rating may cause permanent damage to the device. Extended operation at the maximum levels may degrade performance and affect reliability.
- 2/ Unless otherwise noted, all voltages are referenced to GND.
- 3/ The limits for the parameters specified herein shall apply over the full specified  $V_{CC}$  range and case temperature range of  $-55^\circ\text{C}$  to  $+125^\circ\text{C}$ .
- 4/ The input and output negative voltage ratings may be exceeded provided that the input and output clamp current ratings are observed.
- 5/ The value of  $V_{CC}$  is provided in the recommended operating conditions section 1.4.
- 6/ The maximum package power dissipation is calculated using a junction temperature of  $150^\circ\text{C}$  and a board trace length of 750 mils.
- 7/ Unused inputs must be held high or low to prevent them from floating.

<b>STANDARD MICROCIRCUIT DRAWING</b> DLA LAND AND MARITIME COLUMBUS, OHIO 43218-3990	SIZE <b>A</b>		<b>5962-97626</b>
		REVISION LEVEL D	SHEET 3

2. APPLICABLE DOCUMENTS

2.1 Government specification, standards, and handbooks. The following specification, standards, and handbooks form a part of this drawing to the extent specified herein. Unless otherwise specified, the issues of these documents are those cited in the solicitation or contract.

DEPARTMENT OF DEFENSE SPECIFICATION

MIL-PRF-38535 - Integrated Circuits, Manufacturing, General Specification for.

DEPARTMENT OF DEFENSE STANDARDS

MIL-STD-883 - Test Method Standard Microcircuits.  
 MIL-STD-1835 - Interface Standard Electronic Component Case Outlines.

DEPARTMENT OF DEFENSE HANDBOOKS

MIL-HDBK-103 - List of Standard Microcircuit Drawings.  
 MIL-HDBK-780 - Standard Microcircuit Drawings.

(Copies of these documents are available online at <https://quicksearch.dla.mil/>.)

2.2 Order of precedence. In the event of a conflict between the text of this drawing and the references cited herein, the text of this drawing takes precedence. Nothing in this document, however, supersedes applicable laws and regulations unless a specific exemption has been obtained.

3. REQUIREMENTS

3.1 Item requirements. The individual item requirements for device classes Q and V shall be in accordance with MIL-PRF-38535 as specified herein, or as modified in the device manufacturer's Quality Management (QM) plan. The modification in the QM plan shall not affect the form, fit, or function as described herein.

3.2 Design, construction, and physical dimensions. The design, construction, and physical dimensions shall be as specified in MIL-PRF-38535 and herein for device classes Q and V.

3.2.1 Case outlines. The case outlines shall be in accordance with 1.2.4 herein.

3.2.2 Terminal connections. The terminal connections shall be as specified on figure 1.

3.2.3 Truth table. The truth table shall be as specified on figure 2.

3.2.4 Logic diagram. The logic diagram shall be as specified on figure 3.

3.2.5 Ground bounce test circuit and waveforms. The ground bounce test circuit and waveforms shall be as specified on figure 4.

3.2.6 Switching waveforms and test circuit. The switching waveforms and test circuit shall be as specified on figure 5.

<b>STANDARD MICROCIRCUIT DRAWING</b> DLA LAND AND MARITIME COLUMBUS, OHIO 43218-3990	SIZE <b>A</b>		<b>5962-97626</b>
		REVISION LEVEL D	SHEET 4

3.3 Electrical performance characteristics and postirradiation parameter limits. Unless otherwise specified herein, the electrical performance characteristics and postirradiation parameter limits are as specified in table I and shall apply over the full case operating temperature range.

3.4 Electrical test requirements. The electrical test requirements shall be the subgroups specified in table II. The electrical tests for each subgroup are defined in table I.

3.5 Marking. The part shall be marked with the PIN listed in 1.2 herein. In addition, the manufacturer's PIN may also be marked. For packages where marking of the entire SMD PIN number is not feasible due to space limitations, the manufacturer has the option of not marking the "5962-" on the device. For RHA product using this option, the RHA designator shall still be marked. Marking for device classes Q and V shall be in accordance with MIL-PRF-38535.

3.5.1 Certification/compliance mark. The certification mark for device classes Q and V shall be a "QML" or "Q" as required in MIL-PRF-38535.

3.6 Certificate of compliance. For device classes Q and V, a certificate of compliance shall be required from a QML-38535 listed manufacturer in order to supply to the requirements of this drawing (see 6.6.1 herein). The certificate of compliance submitted to DLA Land and Maritime-VA prior to listing as an approved source of supply for this drawing shall affirm that the manufacturer's product meets, for device classes Q and V, the requirements of MIL-PRF-38535 and herein.

3.7 Certificate of conformance. A certificate of conformance as required for device classes Q and V in MIL-PRF-38535 shall be provided with each lot of microcircuits delivered to this drawing.

<b>STANDARD MICROCIRCUIT DRAWING</b> DLA LAND AND MARITIME COLUMBUS, OHIO 43218-3990	SIZE <b>A</b>		<b>5962-97626</b>
		REVISION LEVEL D	SHEET 5

TABLE I. Electrical performance characteristics.

Test and MIL-STD-883 test method <u>1/</u>	Symbol	Test conditions <u>2/</u> -55°C ≤ T <sub>C</sub> ≤ +125°C +2.0 V ≤ V <sub>CC</sub> ≤ +3.6 V unless otherwise specified		V <sub>CC</sub>	Group A subgroups	Limits <u>3/</u>		Unit
						Min	Max	
High level output voltage 3006	V <sub>OH</sub>	For all inputs affecting output under test V <sub>IN</sub> = V <sub>IH</sub> = 2.0 V or V <sub>IL</sub> = 0.8 V For all other inputs V <sub>IN</sub> = V <sub>CC</sub> or GND	I <sub>OH</sub> = -100 μA	2.7 V and 3.6 V	1, 2, 3	V <sub>CC</sub> -0.2		V
			I <sub>OH</sub> = -12 mA	2.7 V	1, 2, 3	2.2		
				3.0 V		2.4		
			I <sub>OH</sub> = -24 mA	3.0 V	1, 2, 3	2.2		
Low level output voltage 3007	V <sub>OL</sub>	For all inputs affecting output under test V <sub>IN</sub> = V <sub>IH</sub> = 2.0 V or V <sub>IL</sub> = 0.8 V For all other inputs V <sub>IN</sub> = V <sub>CC</sub> or GND	I <sub>OL</sub> = 100 μA	2.7 V and 3.6 V	1, 2, 3		0.2	V
			I <sub>OL</sub> = 12 mA	2.7 V	1, 2, 3		0.4	
			I <sub>OL</sub> = 24 mA	3.0 V	1, 2, 3		0.55	
Input current high 3010	I <sub>IH</sub> <u>4/</u>	For input under test, V <sub>IN</sub> = 5.5 V For all other inputs, V <sub>IN</sub> = V <sub>CC</sub> or GND		3.6 V	1, 2, 3		+5.0	μA
Input current low 3009	I <sub>IL</sub> <u>4/</u>	For input under test, V <sub>IN</sub> = 0.0 V For all other inputs, V <sub>IN</sub> = V <sub>CC</sub> or GND		3.6 V	1, 2, 3		-5.0	μA
Off-state leakage current	I <sub>OFF</sub>	For input/output under test, V <sub>IN</sub> or V <sub>OUT</sub> = 5.5 V For all other inputs, V <sub>IN</sub> = V <sub>CC</sub> or GND		0.0 V	1, 2, 3		±15.0	μA
Three-state output current high 3021	I <sub>OZH</sub> <u>5/</u>	For control inputs affecting output under test, V <sub>IN</sub> = V <sub>IH</sub> = 2.0 V or V <sub>IL</sub> = 0.8 V V <sub>OUT</sub> = 5.5 V		3.6 V	1, 2, 3		+30.0	μA
Three-state output current low 3020	I <sub>OZL</sub> <u>5/</u>	For control inputs affecting output under test, V <sub>IN</sub> = V <sub>IH</sub> = 2.0 V or V <sub>IL</sub> = 0.8 V V <sub>OUT</sub> = 0.0 V		3.6 V	1, 2, 3		-30.0	μA
Quiescent supply current 3005	I <sub>CC</sub>	For all inputs, V <sub>IN</sub> = V <sub>CC</sub> or GND I <sub>OUT</sub> = 0.0 A		3.6 V	1, 2, 3		20.0	μA
		3.6 V ≤ V <sub>IN</sub> ≤ 5.5 V I <sub>OUT</sub> = 0.0 A <u>6/</u>		3.6 V	1, 2, 3		20.0	μA
Quiescent supply current delta, TTL input levels 3005	ΔI <sub>CC</sub>	One input at V <sub>CC</sub> -0.6 V, Other inputs at V <sub>CC</sub> or GND		2.7 V and 3.6 V	1, 2, 3		500.0	μA
Input capacitance 3012	C <sub>IN</sub>	T <sub>C</sub> = +25°C, V <sub>bias</sub> = 2.5 V See 4.4.1c	Control Inputs	3.3 V	4		12.0	pF
Input/output capacitance 3012	C <sub>I/O</sub>	T <sub>C</sub> = +25°C, V <sub>bias</sub> = 2.5V See 4.4.1c	A or B ports	3.3 V	4		17.0	pF

See footnotes at end of table.

<b>STANDARD MICROCIRCUIT DRAWING</b> DLA LAND AND MARITIME COLUMBUS, OHIO 43218-3990	SIZE <b>A</b>		<b>5962-97626</b>
		REVISION LEVEL <b>D</b>	SHEET <b>6</b>

TABLE I. Electrical performance characteristics - Continued.

Test and MIL-STD-883 test method <u>1/</u>	Symbol	Test conditions <u>2/</u> -55°C ≤ T <sub>C</sub> ≤ +125°C +2.0 V ≤ V <sub>CC</sub> ≤ +3.6 V unless otherwise specified		V <sub>CC</sub>	Group A subgroups	Limits <u>3/</u>		Unit
						Min	Max	
Power dissipation capacitance per buffer driver	C <sub>PD</sub>	f = 10 MHz See 4.4.1c	Outputs enabled	3.3 V	4		75.0	pF
Low level ground bounce noise	V <sub>OLP</sub> <u>7/</u>	V <sub>IH</sub> = 2.7, V <sub>IL</sub> = 0.0 V T <sub>A</sub> = +25°C See 4.4.1d		3.0 V	4		1200	mV
Low level ground bounce noise	V <sub>OLV</sub> <u>7/</u>			3.0 V	4		-650	
High level V <sub>CC</sub> bounce noise	V <sub>OHP</sub> <u>7/</u>			3.0 V	4		300	
High level V <sub>CC</sub> bounce noise	V <sub>OHV</sub> <u>7/</u>			3.0 V	4		-1250	
Clock frequency	f <sub>clock</sub>	C <sub>L</sub> 50 pF minimum R <sub>L</sub> = 500Ω See figure 5		3.0 V and 3.6 V	9, 10,11	0	150	MHz
				2.7 V	9, 10,11	0	150	
Pulse duration, high or low, CLKAB or CLKBA	t <sub>w</sub>	C <sub>L</sub> 50 pF minimum R <sub>L</sub> = 500Ω See figure 5		3.0 V and 3.6 V	9, 10,11	3.3		ns
				2.7 V	9, 10,11	3.3		
Setup time, A <sub>n</sub> before CLKAB↑ or B <sub>n</sub> before CLKBA↑	t <sub>su</sub>	C <sub>L</sub> 50 pF minimum R <sub>L</sub> = 500Ω See figure 5		3.0 V and 3.6 V	9, 10,11	1.5		ns
				2.7 V	9, 10,11	1.6		
Hold time, high or low A <sub>n</sub> after CLKAB↑ or B <sub>n</sub> after CLKBA↑	t <sub>h</sub>	C <sub>L</sub> 50 pF minimum R <sub>L</sub> = 500Ω See figure 5		3.0 V and 3.6 V	9, 10,11	1.7		ns
				2.7 V	9, 10,11	1.7		
Functional test 3014	<u>8/</u>	V <sub>IN</sub> = V <sub>IH</sub> or V <sub>IL</sub> Verify output V <sub>OUT</sub> See 4.4.1b		1.5 V, 2.0 V 2.7 V, 3.0 V 3.6 V	7, 8	L	H	
Maximum operating frequency	f <sub>max</sub>	C <sub>L</sub> = 50 pF minimum, R <sub>L</sub> = 500Ω See Figure 5		3.0 V and 3.6 V	9, 10,11	150		MHz
				2.7 V	9, 10,11	150		
Propagation delay time, A <sub>n</sub> to B <sub>n</sub> or B <sub>n</sub> to A <sub>n</sub> 3003	t <sub>PHL1</sub> , t <sub>PLH1</sub>	C <sub>L</sub> = 50 pF minimum, R <sub>L</sub> = 500Ω See Figure 5		3.0 V and 3.6 V	9, 10,11	1.0	7.4	ns
				2.7 V			7.9	

See footnotes at end of table.

<b>STANDARD MICROCIRCUIT DRAWING</b> DLA LAND AND MARITIME COLUMBUS, OHIO 43218-3990	SIZE <b>A</b>		<b>5962-97626</b>
		REVISION LEVEL <b>D</b>	SHEET <b>7</b>

TABLE I. Electrical performance characteristics - Continued.

Test and MIL-STD-883 test method <u>1/</u>	Symbol	Test conditions <u>2/</u> -55°C ≤ T <sub>C</sub> ≤ +125°C +2.0 V ≤ V <sub>CC</sub> ≤ +3.6 V unless otherwise specified	V <sub>CC</sub>	Group A subgroups	Limits <u>3/</u>		Unit
					Min	Max	
Propagation delay time, CLKAB to An or CLKBA to Bn 3003	t <sub>PHL2</sub> , t <sub>PLH2</sub>	C <sub>L</sub> = 50 pF minimum R <sub>L</sub> = 500Ω See Figure 5	3.0 V and 3.6 V	9, 10,11	1.0	8.4	ns
			2.7 V				
Propagation delay time, SAB to An or SBA to Bn 3003	t <sub>PHL3</sub> , t <sub>PLH3</sub>	C <sub>L</sub> = 50 pF minimum R <sub>L</sub> = 500Ω See Figure 5	3.0 V and 3.6 V	9, 10,11	1.0	8.6	ns
			2.7 V				
Propagation delay time, output enable, $\overline{OE}$ to An or Bn 3003	t <sub>PZL1</sub> , t <sub>PZH1</sub>	C <sub>L</sub> = 50 pF minimum R <sub>L</sub> = 500Ω See Figure 5	3.0 V and 3.6 V	9, 10,11	1.0	8.2	ns
			2.7 V				
Propagation delay time, output disable, $\overline{OE}$ to An or Bn 3003	t <sub>PLZ1</sub> , t <sub>PHZ1</sub>	C <sub>L</sub> = 50 pF minimum R <sub>L</sub> = 500Ω See Figure 5	3.0 V and 3.6 V	9, 10,11	1.0	7.5	ns
			2.7 V				
Propagation delay time, output enable, DIR to An or Bn 3003	t <sub>PZL2</sub> , t <sub>PZH2</sub>	C <sub>L</sub> = 50 pF minimum R <sub>L</sub> = 500Ω See Figure 5	3.0 V and 3.6 V	9, 10,11	1.0	8.3	ns
			2.7 V				
Propagation delay time, output disable, DIR to An or Bn 3003	t <sub>PLZ2</sub> , t <sub>PHZ2</sub>	C <sub>L</sub> = 50 pF minimum R <sub>L</sub> = 500Ω See Figure 5	3.0 V and 3.6 V	9, 10,11	1.0	7.9	ns
			2.7 V				

- 1/ For tests not listed in the referenced MIL-STD-883 (e.g. ΔI<sub>CC</sub>), utilize the general test procedure of 883 under the conditions listed herein.
- 2/ Each input/output, as applicable, shall be tested at the specified temperature, for the specified limits, to the tests in table I herein. Output terminals not designated shall be high level logic, low level logic, or open, except for all I<sub>CC</sub> and ΔI<sub>CC</sub> tests, where the output terminals shall be open. When performing these tests, the current meter shall be placed in the circuit such that all current flows through the meter. For input terminals not designated, V<sub>IN</sub> = GND or V<sub>IN</sub> ≥ 3.6 V. The values to be used for V<sub>IH</sub> and V<sub>IL</sub> shall be the V<sub>IH</sub> minimum and V<sub>IL</sub> maximum values listed in section 1.4 herein.
- 3/ For negative and positive voltage and current values, the sign designates the potential difference in reference to GND and the direction of current flow, respectively; and the absolute value of the magnitude, not the sign, is relative to the minimum and maximum limits, as applicable, listed herein.

<b>STANDARD MICROCIRCUIT DRAWING</b> DLA LAND AND MARITIME COLUMBUS, OHIO 43218-3990	SIZE <b>A</b>		<b>5962-97626</b>
		REVISION LEVEL <b>D</b>	SHEET <b>8</b>



TABLE I. Electrical performance characteristics – Continued.

- 4/ For I/O ports, the limit includes  $I_{OZH}$  or  $I_{OZL}$  leakage current from the output circuitry.
- 5/ For I/O ports, the limit includes  $I_{IH}$  or  $I_{IL}$  leakage current from the input circuitry.
- 6/ This applies in the disabled state only.
- 7/ This test is for qualification only. Ground and  $V_{CC}$  bounce tests are performed on a non-switching (quiescent) output and are used to measure the magnitude of induced noise caused by other simultaneously switching outputs. The test is performed on a low noise bench test fixture. For the device under test, all outputs shall be loaded with  $500\Omega$  of load resistance and a minimum of 50 pF of load capacitance (see figure 4). Only chip capacitors and resistors shall be used. The output load components shall be located as close as possible to the device outputs. It is suggested, that whenever possible, this distance be kept to less than 0.25 inches. Decoupling capacitors shall be placed in parallel from  $V_{CC}$  to ground. The values of these decoupling capacitors shall be determined by the device manufacturer. The low and high level ground and  $V_{CC}$  bounce noise is measured at the quiet output using a 1 GHz minimum bandwidth oscilloscope with a  $50\Omega$  input impedance.

The device inputs shall be conditioned such that all outputs are at a high nominal  $V_{OH}$  level. The device inputs shall then be conditioned such that they switch simultaneously and the output under test remains at  $V_{OH}$  as all other outputs possible are switched from  $V_{OH}$  to  $V_{OL}$ .  $V_{OHV}$  and  $V_{OHP}$  are then measured from the nominal  $V_{OH}$  level to the largest negative and positive peaks, respectively (see figure 4). This is then repeated with the same outputs not under test switching from  $V_{OL}$  to  $V_{OH}$ .

The device inputs shall be conditioned such that all outputs are at a low nominal  $V_{OL}$  level. The device inputs shall then be conditioned such that they switch simultaneously and the output under test remains at  $V_{OL}$  as all other outputs possible are switched from  $V_{OL}$  to  $V_{OH}$ .  $V_{OLP}$  and  $V_{OLV}$  are then measured from the nominal  $V_{OL}$  level to the largest positive and negative peaks, respectively (see figure 4). This is then repeated with the same outputs not under test switching from  $V_{OH}$  to  $V_{OL}$ .

- 8/ Tests shall be performed in sequence, attributes data only. Functional tests shall include the truth table and other logic patterns used for fault detection. The test vectors used to verify the truth table shall, at a minimum, test all functions of each input and output. All possible input to output logic patterns per function shall be guaranteed, if not tested, to the truth table in figure 2 herein. Functional tests shall be performed in sequence as approved by the qualifying activity on qualified devices. After incorporating allowable tolerances per MIL-STD-883,  $V_{IL} = 0.4$  V and  $V_{IH} = 2.4$  V. For outputs,  $L \leq 0.8$  V,  $H \geq 2.0$  V.

<b>STANDARD MICROCIRCUIT DRAWING</b> DLA LAND AND MARITIME COLUMBUS, OHIO 43218-3990	SIZE <b>A</b>		<b>5962-97626</b>
		REVISION LEVEL D	SHEET 9

Device type	01	
Case outlines	L, K	3
Terminal number	Terminal symbol	
1	CLKAB	NC
2	SAB	CLKAB
3	DIR	SAB
4	A1	DIR
5	A2	A1
6	A3	A2
7	A4	A3
8	A5	NC
9	A6	A4
10	A7	A5
11	A8	A6
12	GND	A7
13	B8	A8
14	B7	GND
15	B6	NC
16	B5	B8
17	B4	B7
18	B3	B6
19	B2	B5
20	B1	B4
21	$\overline{\text{OE}}$	B3
22	SBA	NC
23	CLKBA	B2
24	V <sub>cc</sub>	B1
25	---	$\overline{\text{OE}}$
26	---	SBA
27	---	CLKBA
28	---	V <sub>cc</sub>

NC = No internal connection

Pin description	
Terminal symbol	Description
A <sub>n</sub> (n = 1 to 8)	Data inputs/outputs, A port
B <sub>n</sub> (n = 1 to 8)	Data inputs/outputs, B port
$\overline{\text{OE}}$	Output enable control input
DIR	Direction control input
CLKAB/CLKBA	Register clock inputs
SAB/SBA	Select-control inputs

FIGURE 1. Terminal connections.

<b>STANDARD MICROCIRCUIT DRAWING</b> DLA LAND AND MARITIME COLUMBUS, OHIO 43218-3990	SIZE <b>A</b>		<b>5962-97626</b>
		REVISION LEVEL D	SHEET 10

Inputs						Data I/O		Operation
$\overline{OE}$	DIR	CLKAB	CLKBA	SAB	SBA	An	Bn	
X	X	↑	X	X	X	Input	Unspecified <u>1/</u>	Store An, Bn unspecified <u>1/</u>
X	X	X	↑	X	X	Unspecified <u>1/</u>	Input	Store Bn, An unspecified <u>1/</u>
H	X	↑	↑	X	X	Input	Input	Store An and Bn data
H	X	H or L	H or L	X	X	Input disabled	Input disabled	Isolation, hold storage
L	L	X	X	X	L	Output	Input	Real-time Bn data to An
L	L	X	H or L	X	H	Output	Input	Stored Bn data to An
L	H	X	X	L	X	Input	Output	Real-time An data to Bn
L	H	H or L	X	H	X	Input	Output	Stored An data to Bn

H = High voltage level  
L = Low voltage level  
X = Irrelevant or don't care  
↑ = Low-to-high clock transition

1/ The data-output functions can be enabled or disabled by various signals at  $\overline{OE}$  and DIR. Data-input functions are always enabled; i.e., data at the bus terminals is stored on every low-to-high transition of the clock inputs.

FIGURE 2. Truth table.

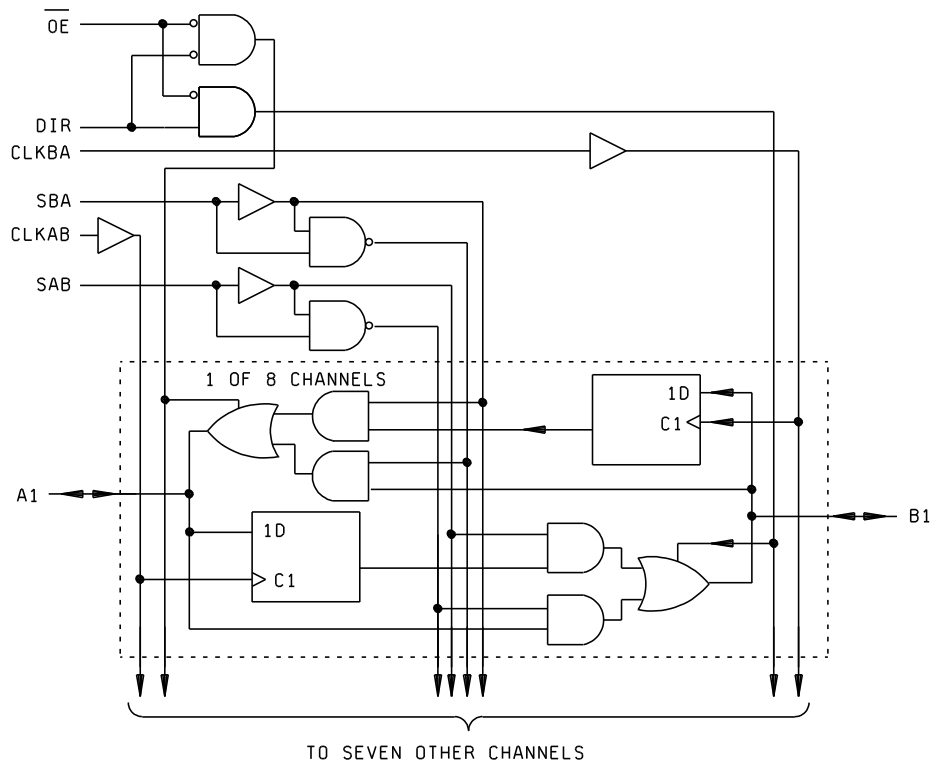
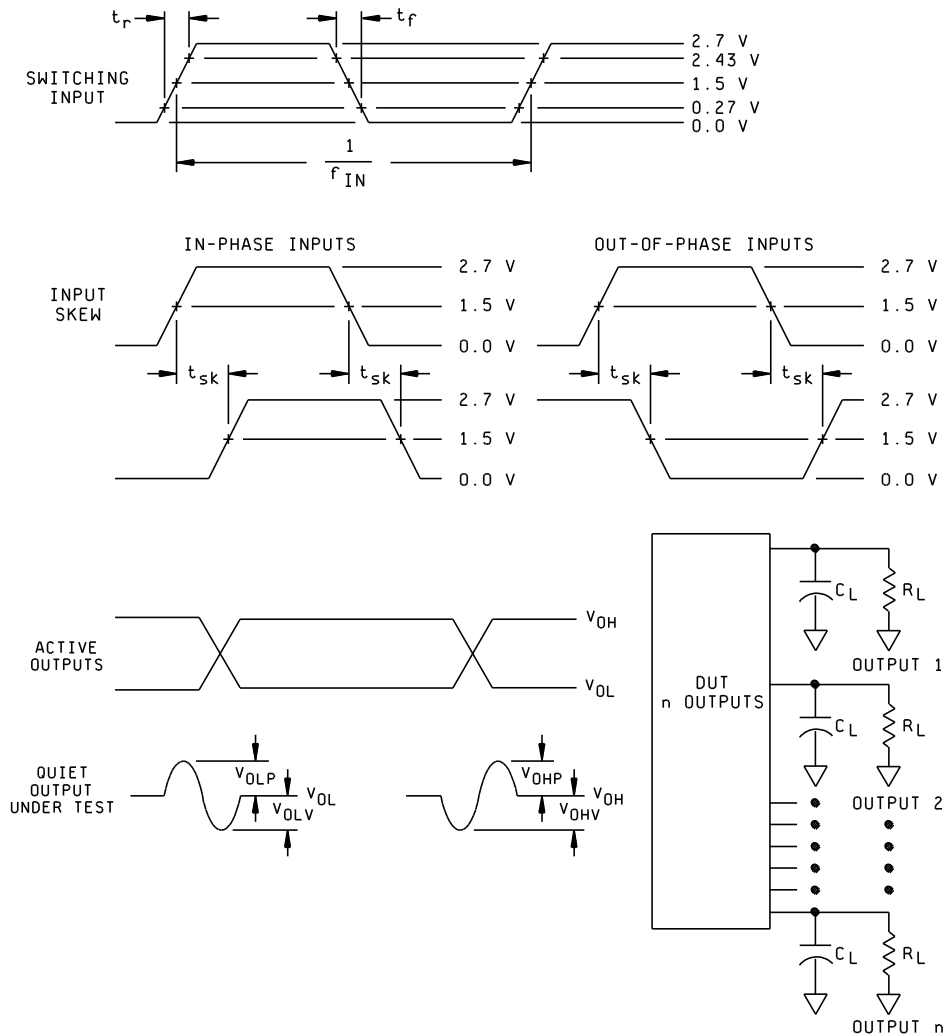

FIGURE 3. Logic diagram.

<b>STANDARD MICROCIRCUIT DRAWING</b> DLA LAND AND MARITIME COLUMBUS, OHIO 43218-3990	SIZE <b>A</b>		<b>5962-97626</b>
		REVISION LEVEL D	SHEET 11



**NOTES:**

1.  $C_L$  includes a 47 pF chip capacitor (-0 percent, +20 percent) and at least 3 pF of equivalent capacitance from the test jig and probe.
2.  $R_L = 450\Omega \pm 1$  percent, chip resistor in series with a  $50\Omega$  termination. For monitored outputs, the  $50\Omega$  termination shall be the  $50\Omega$  characteristic impedance of the coaxial connector to the oscilloscope.
3. Input signal to the device under test:
  - a.  $V_{IN} = 0.0$  V to 2.7 V; duty cycle = 50 percent;  $f_{IN} \geq 1$  MHz.
  - b.  $t_r, t_f = 3.0$  ns  $\pm 1.0$  ns. For input signal generators incapable of maintaining these values of  $t_r$  and  $t_f$ , the 3.0 ns limit may be increased up to 10 ns, as needed, maintaining the  $\pm 1.0$  ns tolerance and guaranteeing the results at 3.0 ns  $\pm 1.0$  ns; skew between any two switching inputs signals ( $t_{sk}$ ):  $\leq 250$  ps.

FIGURE 4. Ground bounce test circuit and waveforms.

<b>STANDARD MICROCIRCUIT DRAWING</b> DLA LAND AND MARITIME COLUMBUS, OHIO 43218-3990	SIZE <b>A</b>		<b>5962-97626</b>
		REVISION LEVEL <b>D</b>	SHEET 12

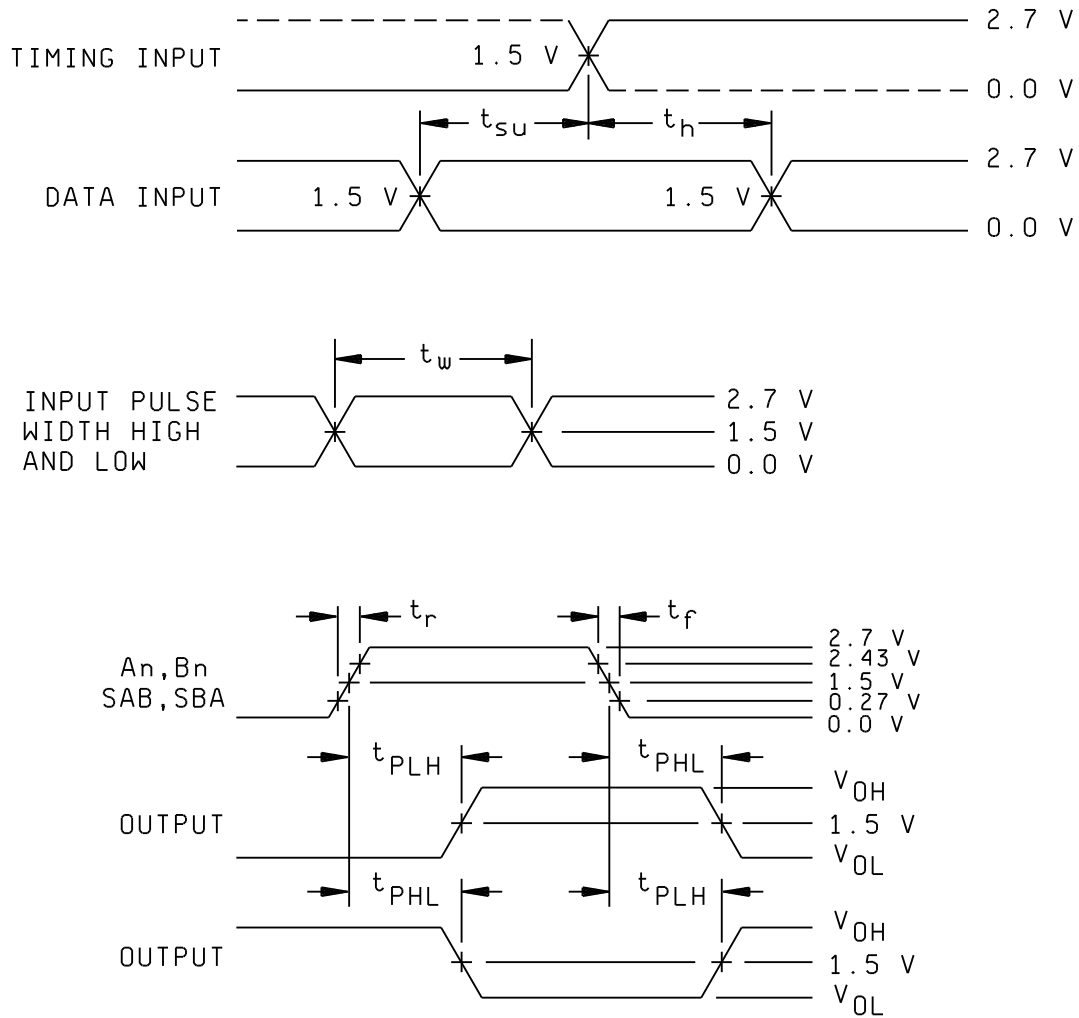

FIGURE 5. Switching waveforms and test circuit.

**STANDARD  
MICROCIRCUIT DRAWING**  
DLA LAND AND MARITIME  
COLUMBUS, OHIO 43218-3990

SIZE  
**A**

REVISION LEVEL  
D

**5962-97626**

SHEET  
13

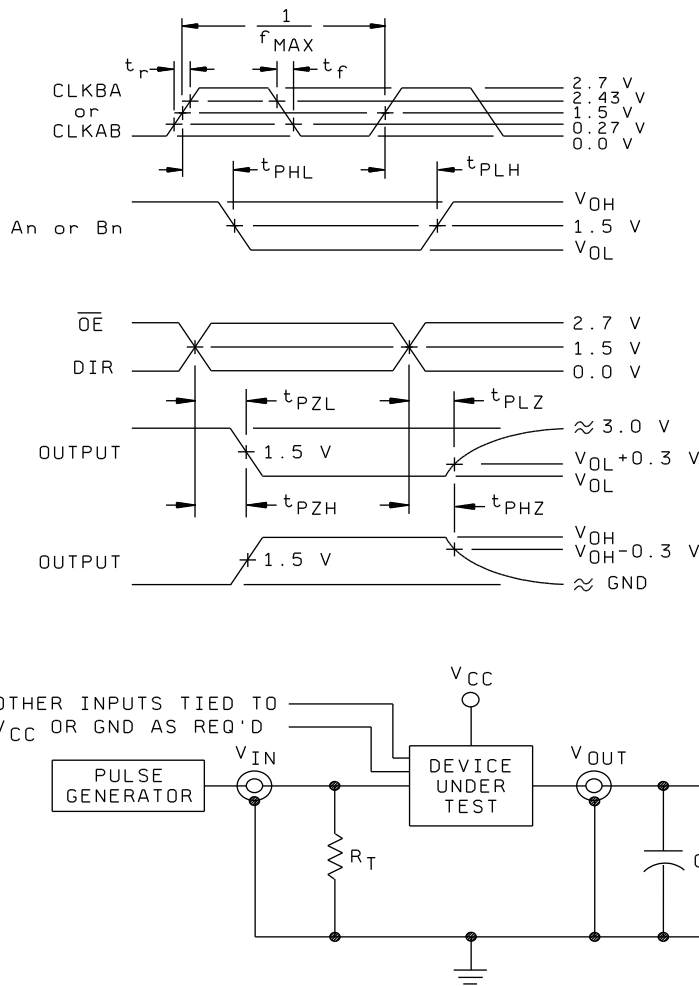

**NOTES:**

1. When measuring  $t_{PLH}$  and  $t_{PHL}$ :  $V_{TEST} = \text{Open}$ .
2. When measuring  $t_{PLZ}$  and  $t_{PZL}$ :  $V_{TEST} = 6.0$  V
3. When measuring  $t_{PHZ}$  and  $t_{PZH}$ :  $V_{TEST} = GND$ .
4. The  $t_{PZL}$  and  $t_{PLZ}$  reference waveform is for the output under test with internal conditions such that the output is at  $V_{OL}$  except when disabled by the output enable control. The  $t_{PZH}$  and  $t_{PHZ}$  reference waveform is for the output under test with internal conditions such that the output is at  $V_{OH}$  except when disabled by the output enable control.
5.  $C_L = 50$  pF (includes test jig and probe capacitance).
6.  $R_T = 50\Omega$ ,  $R_L = 500\Omega$  or equivalent.
7. Input signal from pulse generator:  $V_{IN} = 0.0$  V to 2.7 V;  $PRR \leq 1$  MHz;  $t_r = 2.5$  ns;  $t_f = 2.5$  ns;  $t_r$  and  $t_f$  shall be measured from 0.27 V to 2.43V and from 2.43 V to 0.27 V, respectively; duty cycle = 50 percent.
8. Timing parameters shall be tested at a minimum input frequency of 1 MHz.
9. The outputs are measured one at a time with one transition per measurement.

FIGURE 5. Switching waveforms and test circuit - Continued.

<b>STANDARD MICROCIRCUIT DRAWING</b> DLA LAND AND MARITIME COLUMBUS, OHIO 43218-3990	SIZE <b>A</b>		<b>5962-97626</b>
		REVISION LEVEL <b>D</b>	SHEET 14

4. VERIFICATION

4.1 Sampling and inspection. For device classes Q and V, sampling and inspection procedures shall be in accordance with MIL-PRF-38535 or as modified in the device manufacturer's Quality Management (QM) plan. The modification in the QM plan shall not affect the form, fit, or function as described herein.

4.2 Screening. For device classes Q and V, screening shall be in accordance with MIL-PRF-38535, and shall be conducted on all devices prior to qualification and technology conformance inspection.

4.2.1 Additional criteria for device classes Q and V.

- a. The burn-in test duration, test condition and test temperature, or approved alternatives shall be as specified in the device manufacturer's QM plan in accordance with MIL-PRF-38535. The burn-in test circuit shall be maintained under document revision level control of the device manufacturer's Technology Review Board (TRB) in accordance with MIL-PRF-38535 and shall be made available to the acquiring or preparing activity upon request. The test circuit shall specify the inputs, outputs, biases, and power dissipation, as applicable, in accordance with the intent specified in method 1015 of MIL-STD-883.
- b. Interim and final electrical test parameters shall be as specified in table II herein.
- c. Additional screening for device class V beyond the requirements of device class Q shall be as specified in MIL-PRF-38535, appendix B.

4.3 Qualification inspection for device classes Q and V. Qualification inspection for device classes Q and V shall be in accordance with MIL-PRF-38535. Inspections to be performed shall be those specified in MIL-PRF-38535 and herein for groups A, B, C, D, and E inspections (see 4.4.1 through 4.4.4).

4.4 Conformance inspection. Technology conformance inspection for classes Q and V shall be in accordance with MIL-PRF-38535 including groups A, B, C, D, and E inspections, and as specified herein.

TABLE II. Electrical test requirements.

Test requirements	Subgroups (in accordance with MIL-PRF-38535, table III)	
	Device class Q	Device class V
Interim electrical parameters (see 4.2)	---	1
Final electrical parameters (see 4.2)	1/ 1, 2, 3, 7, 8, 9, 10, 11	2/, 3/ 1, 2, 3, 7, 8, 9, 10, 11
Group A test requirements (see 4.4)	1, 2, 3, 4, 7, 8, 9, 10, 11	1, 2, 3, 4, 7, 8, 9, 10, 11
Group C end-point electrical parameters (see 4.4)	1, 2, 3	3/ 1, 2, 3, 7, 8, 9, 10, 11
Group D end-point electrical parameters (see 4.4)	1, 2, 3	1, 2, 3
Group E end-point electrical parameters (see 4.4)	1, 7, 9	1, 7, 9

1/ PDA applies to subgroup 1.

2/ PDA applies to subgroups 1, 7.

3/ Delta limits, as specified in table III herein shall be required where specified, and the delta limits shall be computed with reference to the zero hour electrical parameters.

<b>STANDARD MICROCIRCUIT DRAWING</b> DLA LAND AND MARITIME COLUMBUS, OHIO 43218-3990	SIZE <b>A</b>		<b>5962-97626</b>
		REVISION LEVEL D	SHEET 15

TABLE III. Burn-in and operating life test, delta parameters (+25°C).

Parameters	Symbol	Delta limits
High level supply current	I <sub>CCH</sub>	±2 μA
Low level supply current	I <sub>CCL</sub>	±2 μA
Supply current level disabled	I <sub>CCZ</sub>	±2 μA
Input current	I <sub>I</sub>	±0.5 μA
High level input current	I <sub>IH</sub>	±0.5 μA
Low level input current	I <sub>IL</sub>	±0.5 μA
Off-state output current low	I <sub>OZL</sub>	±3 μA
Off-state output current high	I <sub>OZH</sub>	±3 μA
Output voltage low level (V <sub>CC</sub> = 2.7 V, I <sub>OL</sub> = 12 mA)	V <sub>OL</sub>	±40 mV
Output voltage low level (V <sub>CC</sub> = 3.0 V, I <sub>OL</sub> = 24 mA)	V <sub>OL</sub>	±55 mV
Output voltage high level (V <sub>CC</sub> = 2.7 V, I <sub>OH</sub> = -12 mA)	V <sub>OH</sub>	±220 mV
Output voltage high level (V <sub>CC</sub> = 3.0 V, I <sub>OH</sub> = -12 mA)	V <sub>OH</sub>	±240 mV
Output voltage high level (V <sub>CC</sub> = 3.0 V, I <sub>OH</sub> = -24 mA)	V <sub>OH</sub>	±220 mV

4.4.1 Group A inspection.

- a. Tests shall be as specified in table IIA herein.
- b. For device classes Q and V, subgroups 7 and 8 shall include verifying the functionality of the device.
- c. C<sub>IN</sub>, C<sub>I/O</sub>, and C<sub>PD</sub> shall be measured only for initial qualification and after process or design changes which may affect capacitance. C<sub>IN</sub> and C<sub>I/O</sub> shall be measured between the designated terminal and GND at a frequency of 1 MHz. This test may be performed at 10 MHz and guaranteed, if not tested, at 1 MHz. The DC bias for the pin under test (V<sub>BIAS</sub>) = 2.5 V or 3.0 V. For C<sub>IN</sub>, C<sub>I/O</sub>, and C<sub>PD</sub>, test all applicable pins on five devices with zero failures.

For C<sub>IN</sub> and C<sub>I/O</sub>, a device manufacturer may qualify devices by functional groups. A specific functional group shall be composed of function types, that by design, will yield the same capacitance values when tested in accordance with table I, herein. The device manufacturer shall set a function group limit for the C<sub>IN</sub> and C<sub>I/O</sub> tests. The device manufacturer may then test one device functional group, to the limits and conditions specified herein. All other device functions in that particular functional group shall be guaranteed, if not tested, to the limits and test conditions specified in table I, herein. The device manufacturers shall submit to DLA Land and Maritime-VA the device functions listed in each functional group and the test results for each device tested.

<b>STANDARD MICROCIRCUIT DRAWING</b> DLA LAND AND MARITIME COLUMBUS, OHIO 43218-3990	SIZE <b>A</b>		<b>5962-97626</b>
		REVISION LEVEL D	SHEET 16



- d. Ground and  $V_{CC}$  bounce tests are required for all device classes. These tests shall be performed only for initial qualification, after process or design changes which may affect the performance of the device, and any changes to the test fixture.  $V_{OLP}$ ,  $V_{OLV}$ ,  $V_{OHP}$ , and  $V_{OHV}$  shall be measured for the worst case outputs of the device. All other outputs shall be guaranteed, if not tested, to the limits established for the worst case outputs. The worst case outputs tested are to be determined by the manufacturer. Test 5 devices assembled in the worst case package type supplied to this document. All other package types shall be guaranteed, if not tested, to the limits established for the worst case package. The 5 devices to be tested shall be the worst case device type supplied to this drawing. All other device types shall be guaranteed, if not tested, to the limits established for the worst case device type. The package type and device type to be tested shall be determined by the manufacturer. The device manufacturer will submit to DLA Land and Maritime-VA data that shall include all measured peak values for each device tested and detailed oscilloscope plots for each  $V_{OLP}$ ,  $V_{OLV}$ ,  $V_{OHP}$ , and  $V_{OHV}$  from one sample part per function. The plot shall contain the waveforms of both a switching output and the output under test.

Each device manufacturer shall test product on the fixtures they currently use. When a new fixture is used, the device manufacturer shall inform DLA Land and Maritime-VA of this change and test the 5 devices on both the new and old test fixtures. The device manufacturer shall then submit to DLA Land and Maritime-VA data from testing on both fixtures, that shall include all measured peak values for each device tested and detailed oscilloscope plots for each  $V_{OLP}$ ,  $V_{OLV}$ ,  $V_{OHP}$ , and  $V_{OHV}$  from one sample part per function. The plot shall contain the waveforms of both a switching output and the output under test.

For  $V_{OHP}$ ,  $V_{OHV}$ ,  $V_{OLP}$ , and  $V_{OLV}$ , a device manufacturer may qualify devices by functional groups. A specific functional group shall be composed of function types, that by design, will yield the same test values when tested in accordance with table I, herein. The device manufacturer shall set a functional group limit for the  $V_{OHP}$ ,  $V_{OHV}$ ,  $V_{OLP}$ , and  $V_{OLV}$  tests. The device manufacturer may then test one device function from a functional group, to the limits and conditions specified herein. All other device functions in that particular functional group shall be guaranteed, if not tested, to the limits and conditions specified in table I, herein. The device manufacturers shall submit to DLA Land and Maritime-VA the device functions listed in each functional group and test results, along with the oscilloscope plots, for each device tested.

4.4.2 Group C inspection. The group C inspection end-point electrical parameters shall be as specified in table II herein.

4.4.2.1 Additional criteria for device classes Q and V. The steady-state life test duration, test condition and test temperature, or approved alternatives shall be as specified in the device manufacturer's QM plan in accordance with MIL-PRF-38535. The test circuit shall be maintained under document revision level control by the device manufacturer's TRB in accordance with MIL-PRF-38535 and shall be made available to the acquiring or preparing activity upon request. The test circuit shall specify the inputs, outputs, biases, and power dissipation, as applicable, in accordance with the intent specified in method 1005 of MIL-STD-883.

4.4.3 Group D inspection. The group D inspection end-point electrical parameters shall be as specified in table II herein.

4.4.4 Group E inspection. Group E inspection is required only for parts intended to be marked as radiation hardness assured (see 3.5 herein).

- a. End-point electrical parameters shall be as specified in table II herein.
- b. For device classes Q and V, the devices or test vehicle shall be subjected to radiation hardness assured tests as specified in MIL-PRF-38535 for the RHA level being tested. All device classes must meet the postirradiation end-point electrical parameter limits as defined in table I at  $T_A = +25^{\circ}\text{C} \pm 5^{\circ}\text{C}$ , after exposure, to the subgroups specified in table II herein.

4.5 Methods of inspection. Methods of inspection shall be specified as follows:

4.5.1 Voltage and current. Unless otherwise specified, all voltages given are referenced to the microcircuit GND terminal. Currents given are conventional current and positive when flowing into the referenced terminal.

<b>STANDARD MICROCIRCUIT DRAWING</b> DLA LAND AND MARITIME COLUMBUS, OHIO 43218-3990	SIZE <b>A</b>		<b>5962-97626</b>
		REVISION LEVEL D	SHEET 17

5. PACKAGING

5.1 Packaging requirements. The requirements for packaging shall be in accordance with MIL-PRF-38535 for device classes Q and V.

6. NOTES

6.1 Intended use. Microcircuits conforming to this drawing are intended for use for Government microcircuit applications (original equipment), design applications, and logistics purposes.

6.1.1 Replaceability. Microcircuits covered by this drawing will replace the same generic device covered by a contractor prepared specification or drawing.

6.2 Configuration control of SMD's. All proposed changes to existing SMD's will be coordinated with the users of record for the individual documents. This coordination will be accomplished using DD Form 1692, Engineering Change Proposal.

6.3 Record of users. Military and industrial users should inform DLA Land and Maritime when a system application requires configuration control and which SMD's are applicable to that system. DLA Land and Maritime will maintain a record of users and this list will be used for coordination and distribution of changes to the drawings. Users of drawings covering microelectronic devices (FSC 5962) should contact DLA Land and Maritime-VA, telephone (614) 692-8108.

6.4 Comments. Comments on this drawing should be directed to DLA Land and Maritime-VA, Columbus, Ohio 43218-3990, or telephone (614) 692-0591.

6.5 Abbreviations, symbols, and definitions. The abbreviations, symbols, and definitions used herein are defined in MIL-PRF-38535 and MIL-HDBK-1331.

6.6 Sources of supply.

6.6.1 Sources of supply for device classes Q and V. Sources of supply for device classes Q and V are listed in MIL-HDBK-103 and QML-38535. The vendors listed in MIL-HDBK-103 and QML-38535 have submitted a certificate of compliance (see 3.6 herein) to DLA Land and Maritime-VA and have agreed to this drawing.

<b>STANDARD MICROCIRCUIT DRAWING</b> DLA LAND AND MARITIME COLUMBUS, OHIO 43218-3990	SIZE <b>A</b>		<b>5962-97626</b>
		REVISION LEVEL D	SHEET 18

STANDARD MICROCIRCUIT DRAWING BULLETIN

DATE: 21-10-05

Approved sources of supply for SMD 5962-97626 are listed below for immediate acquisition information only and shall be added to MIL-HDBK-103 and QML-38535 during the next revision. MIL-HDBK-103 and QML-38535 will be revised to include the addition or deletion of sources. The vendors listed below have agreed to this drawing and a certificate of compliance has been submitted to and accepted by DLA Land and Maritime-VA. This information bulletin is superseded by the next dated revision of MIL-HDBK-103 and QML-38535. DLA Land and Maritime maintains an online database of all current sources of supply at <https://landandmaritimeapps.dla.mil/programs/smcr/>.

Standard microcircuit drawing PIN <u>1/</u>	Vendor CAGE number	Vendor similar PIN <u>2/</u>
5962-9762601QLA	01295	SNJ54LVC646AJT
5962-9762601QKA	01295	SNJ54LVC646AW
5962-9762601Q3A	01295	SNJ54LVC646AFK
5962-9762601VKA	01295	SNV54LVC646AW

1/ The lead finish shown for each PIN representing a hermetic package is the most readily available from the manufacturer listed for that part. If the desired lead finish is not listed contact the vendor to determine its availability.

2/ Caution. Do not use this number for item acquisition. Items acquired to this number may not satisfy the performance requirements of this drawing.

Vendor CAGE  
number

Vendor name  
and address

01295

Texas Instruments Incorporated  
Semiconductor Group  
8505 Forest Ln.  
P.O. Box 660199  
Dallas, TX 75243

The information contained herein is disseminated for convenience only and the Government assumes no liability whatsoever for any inaccuracies in the information bulletin.