

REVISIONS

LTR	DESCRIPTION	DATE (YR-MO-DA)	APPROVED
A	Update the boilerplate to current requirements as specified in MIL-PRF-38535. Editorial changes throughout. – jak	06-12-06	Thomas M. Hess
B	Update the boilerplate to current requirements as specified in MIL-PRF-38535. Editorial changes throughout. –jwc	14-03-27	Thomas M. Hess
C	Update boilerplate to MIL-PRF-38535 requirements. – DRH	21-02-01	Muhammad A. Akbar



REV																			
SHEET																			
REV																			
SHEET																			

REV STATUS	REV	C	C	C	C	C	C	C	C	C	C	C	C	C	C	C	C	C
OF SHEETS	SHEET	1	2	3	4	5	6	7	8	9	10	11	12	13	14			

PMIC N/A	PREPARED BY Joseph A. Kerby	<p align="center">DLA LAND AND MARITIME COLUMBUS, OHIO 43218-3990 https://www.dla.mil/LandandMaritime</p>																
<p align="center">STANDARD MICROCIRCUIT DRAWING</p> <p>THIS DRAWING IS AVAILABLE FOR USE BY ALL DEPARTMENTS AND AGENCIES OF THE DEPARTMENT OF DEFENSE</p> <p align="center">AMSC N/A</p>	CHECKED BY Thanh V. Nguyen																	
	APPROVED BY Monica L. Poelking	<p align="center">MICROCIRCUIT, DIGITAL, CMOS, MICROPOWER PHASE-LOCKED-LOOP, MONOLITHIC SILICON</p>																
	DRAWING APPROVAL DATE 94-11-10																	
	REVISION LEVEL C		SIZE A	CAGE CODE 67268	5962-94664													
SHEET 1 OF 14																		

1. SCOPE

1.1 Scope. This drawing documents two product assurance class levels consisting of high reliability (device classes M and Q) and space application (device class V). A choice of case outlines and lead finishes are available and are reflected in the Part or Identifying Number (PIN). When available, a choice of radiation hardness assurance (RHA) levels are reflected in the PIN.

1.2 PIN. The PIN is as shown in the following example:

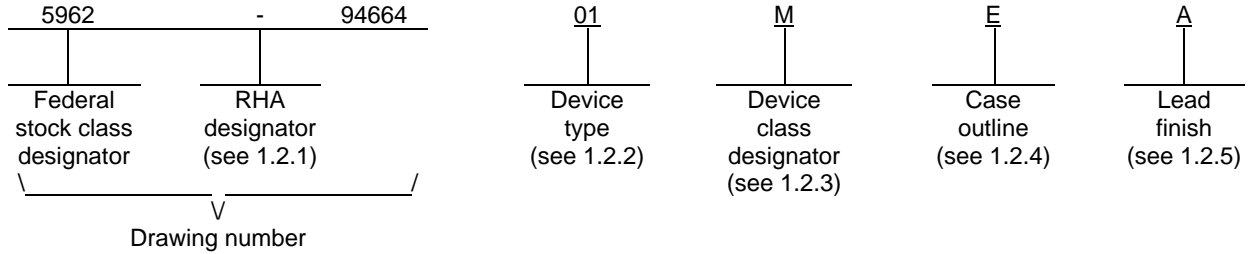

1.2.1 RHA designator. Device classes Q and V RHA marked devices meet the MIL-PRF-38535 specified RHA levels and are marked with the appropriate RHA designator. Device class M RHA marked devices meet the MIL-PRF-38535, appendix A specified RHA levels and are marked with the appropriate RHA designator. A dash (-) indicates a non-RHA device.

1.2.2 Device type(s). The device type(s) identify the circuit function as follows:

<u>Device type</u>	<u>Generic number</u>	<u>Circuit function</u>
01	4046B	Micropower phase-locked-loop

1.2.3 Device class designator. The device class designator is a single letter identifying the product assurance level as follows:

<u>Device class</u>	<u>Device requirements documentation</u>
M	Vendor self-certification to the requirements for MIL-STD-883 compliant, non-JAN class level B microcircuits in accordance with MIL-PRF-38535, appendix A
Q or V	Certification and qualification to MIL-PRF-38535

1.2.4 Case outline(s). The case outline(s) are as designated in MIL-STD-1835 and as follows:

<u>Outline letter</u>	<u>Descriptive designator</u>	<u>Terminals</u>	<u>Package style</u>
E	GDIP1-T16 or CDIP2-T16	16	Dual-in-line

1.2.5 Lead finish. The lead finish is as specified in MIL-PRF-38535 for device classes Q and V or MIL-PRF-38535, appendix A for device class M.

STANDARD MICROCIRCUIT DRAWING DLA LAND AND MARITIME COLUMBUS, OHIO 43218-3990	SIZE A		5962-94664
		REVISION LEVEL C	SHEET 2

1.3 Absolute maximum ratings. 1/

Supply voltage range (V _{DD})	-0.5 V dc to +20 V dc
Input voltage range (V _{IN})	-0.5 V dc to V _{DD} + 0.5 V dc
Storage temperature range (T _{STG})	-65°C to +150°C
Maximum power dissipation (P _D)	500 mW 2/
Lead temperature (soldering, 10 seconds)	+300°C
Thermal resistance, junction-to-case (θ _{JC})	See MIL-STD-1835
Junction temperature (T _J)	+175°C

1.4 Recommended operating conditions.

Supply voltage range (V _{DD}):	
VCO section:	
As fixed oscillator	+3.0 V dc to +18 V dc
Phased-locked-loop operation	+5.0 V dc to +18 V dc
Phase comparator section:	
Comparator	+3.0 V dc to +18 V dc
VCO operation	+5.0 V dc to +18 V dc
Case operating temperature range (T _C)	-55°C to +125°C
Input voltage range (V _{IN})	0 V to V _{DD}
Output voltage range (V _{OUT})	0 V to V _{DD}

2. APPLICABLE DOCUMENTS

2.1 Government specification, standards, and handbooks. The following specification, standards, and handbooks form a part of this drawing to the extent specified herein. Unless otherwise specified, the issues of these documents are those cited in the solicitation or contract.

DEPARTMENT OF DEFENSE SPECIFICATION

MIL-PRF-38535 - Integrated Circuits, Manufacturing, General Specification for.

DEPARTMENT OF DEFENSE STANDARDS

MIL-STD-883 - Test Method Standard Microcircuits.
 MIL-STD-1835 - Interface Standard Electronic Component Case Outlines.

DEPARTMENT OF DEFENSE HANDBOOKS

MIL-HDBK-103 - List of Standard Microcircuit Drawings.
 MIL-HDBK-780 - Standard Microcircuit Drawings.

(Copies of these documents are available online at <https://quicksearch.dla.mil/>).

2.2 Order of precedence. In the event of a conflict between the text of this drawing and the references cited herein, the text of this drawing takes precedence. Nothing in this document, however, supersedes applicable laws and regulations unless a specific exemption has been obtained.

1/ Unless otherwise noted, all voltages are referenced to GND.
 2/ For T_C = +100°C to +125°C, derate linearly at 12 mW/°C to 200 mW.

STANDARD MICROCIRCUIT DRAWING DLA LAND AND MARITIME COLUMBUS, OHIO 43218-3990	SIZE A		5962-94664
		REVISION LEVEL C	SHEET 3

3. REQUIREMENTS

3.1 Item requirements. The individual item requirements for device classes Q and V shall be in accordance with MIL-PRF-38535 and as specified herein or as modified in the device manufacturer's Quality Management (QM) plan. The modification in the QM plan shall not affect the form, fit, or function as described herein. The individual item requirements for device class M shall be in accordance with MIL-PRF-38535, appendix A for non-JAN class level C devices and as specified herein.

3.2 Design, construction, and physical dimensions. The design, construction, and physical dimensions shall be as specified in MIL-PRF-38535 and herein for device classes B, S, Q, and V or MIL-PRF-38535, appendix A and herein for device class M.

3.2.1 Case outlines. The case outlines shall be in accordance with 1.2.2 herein.

3.2.2 Terminal connections. The terminal connections shall be as specified on figure 1.

3.2.3 Block diagram. The block diagram shall be as specified on figure 2.

3.2.6 Switching waveforms and test circuit. The switching waveforms and test circuit shall be as specified on figure 3.

3.3 Electrical performance characteristics and postirradiation parameter limits. Unless otherwise specified herein, the electrical performance characteristics and postirradiation parameter limits are as specified in table I and shall apply over the full case operating temperature range. Test conditions for these specified characteristics and limits are as specified in table I.

3.4 Electrical test requirements. The electrical test requirements shall be the subgroups specified in table II. The electrical tests for each subgroup are defined in table I.

3.5 Marking. The part shall be marked with the PIN listed in 1.2 herein. In addition, the manufacturer's PIN may also be marked. For packages where marking of the entire SMD PIN number is not feasible due to space limitations, the manufacturer has the option of not marking the "5962-" on the device. For RHA product using this option, the RHA designator shall still be marked. Marking for device classes Q and V shall be in accordance with MIL-PRF-38535. Marking for device class M shall be in accordance with MIL-PRF-38535, appendix A.

3.5.1 Certification/compliance mark. The certification mark for device classes Q and V shall be a "QML" or "Q" as required in MIL-PRF-38535. The compliance mark for device class M shall be a "C" as required in MIL-PRF-38535, appendix A.

3.6 Certificate of compliance. For device classes Q and V, a certificate of compliance shall be required from a QML-38535 listed manufacturer in order to supply to the requirements of this drawing (see 6.6.1 herein). For device class M, a certificate of compliance shall be required from a manufacturer in order to be listed as an approved source of supply in MIL-HDBK-103 (see 6.6.2 herein). The certificate of compliance submitted to DLA Land and Maritime -VA prior to listing as an approved source of supply for this drawing shall affirm that the manufacturer's product meets, for device classes Q and V, the requirements of MIL-PRF-38535 and herein or for device class M the requirements of MIL-PRF-38535, appendix A and herein.

3.7 Certificate of conformance. A certificate of conformance as required for device classes Q and V in MIL-PRF-38535 or for device class M in MIL-PRF-38535, appendix A shall be provided with each lot of microcircuits delivered to this drawing.

3.8 Notification of change for device class M. For device class M notification to DLA Land and Maritime-VA of change of product (see 6.2 herein) involving devices acquired to this drawing is required for any change that affects this drawing.

3.9 Verification and review for device class M. For device class M, DLA Land and Maritime, DLA Land and Maritime's agent, and the acquiring activity retain the option to review the manufacturer's facility and applicable required documentation. Offshore documentation shall be made available onshore at the option of the reviewer.

3.10 Microcircuit group assignment for device class M. Device class M devices covered by this drawing shall be in microcircuit group number 105 (see MIL-PRF-38535, appendix A).

STANDARD MICROCIRCUIT DRAWING DLA LAND AND MARITIME COLUMBUS, OHIO 43218-3990	SIZE A		5962-94664
		REVISION LEVEL C	SHEET 4

TABLE I. Electrical performance characteristics.

Test	Symbol	Conditions -55°C ≤ T _C ≤ +125°C unless otherwise specified	Device type	V _{DD}	Group A subgroups	Limits		Unit
						Min	Max	
Low level output current	I _{OL}	V _O = 0.4 V V _{IN} = 0.0 V or V _{DD}	All	5 V	1	0.51		mA
					2 1/	0.36		
					3 1/	0.64		
	V _O = 0.5 V V _{IN} = 0.0 V or V _{DD}	All	10 V	1	1.3			
				2 1/	0.9			
				3 1/	1.6			
	V _O = 1.5 V V _{IN} = 0.0 V or V _{DD}	All	15 V	1	3.4			
				2 1/	2.4			
				3 1/	4.2			
High level output current	I _{OH}	V _O = 4.6 V V _{IN} = 0.0 V or V _{DD}	All	5 V	1	-0.51		mA
					2 1/	-0.36		
					3 1/	-0.64		
	V _O = 2.5 V V _{IN} = 0.0 V or V _{DD}	All	5 V	1	-1.6			
				2 1/	-1.15			
				3 1/	-2.0			
	V _O = 9.5 V V _{IN} = 0.0 V or V _{DD}	All	10 V	1	-1.3			
				2 1/	-0.9			
				3 1/	-1.6			
	V _O = 13.5 V V _{IN} = 0.0 V or V _{DD}	All	15 V	1	-3.4			
				2 1/	-2.4			
				3 1/	-4.2			
Input current	I _{IN}	All terminals except SIGNAL IN V _{IN} = 0.0 V or V _{DD}	All	18 V	1, 3		±0.1	μA
					2		±1.0	
Functional tests		See 4.4.1b	All		7			

VOLTAGE-CONTROLLED OSCILLATOR SECTION

Low level output voltage	V _{OL}	V _{IN} = 0.0 V or V _{DD} VCO OUT driving CMOS e.g., COMPARATOR IN	All	5 V	1, 2, 3		0.05	V
				1/				
				10 V	1, 2, 3		0.05	
				1/				
				15 V	1, 2, 3		0.05	
High level output voltage	V _{OH}	V _{IN} = 0.0 V or V _{DD} VCO OUT driving CMOS e.g., COMPARATOR IN	All	5 V	1, 2, 3	4.95		V
				1/				
				10 V	1, 2, 3	9.95		
				1/				
				15 V	1, 2, 3	14.95		
Zener diode voltage	V _Z	I _Z = 50 μA T _C = +25°C	All		1	4.45	6.5	V
Operating power dissipation	P _D 1/	f _O = 10 MHz R ₁ = 1 MΩ R ₂ = ∞ VCO _{IN} = V _{DD} /2 T _C = +25°C	All	5 V	4		140	mW
				10 V	4		1600	
				15 V	4		6000	

See footnotes at end of table.

STANDARD MICROCIRCUIT DRAWING DLA LAND AND MARITIME COLUMBUS, OHIO 43218-3990	SIZE A		5962-94664
		REVISION LEVEL C	SHEET 5

TABLE I. Electrical performance characteristics – Continued.

Test	Symbol	Conditions -55°C ≤ T _C ≤ +125°C unless otherwise specified	Device type	V _{DD}	Group A subgroups	Limits		Unit
						Min	Max	
Maximum operating frequency	f _{MAX} <u>1/</u>	C ₁ = 50 pF R ₁ = 10 kΩ R ₂ = ∞ VCO _{IN} = V _{DD} T _C = +25°C	All	5 V	9	0.3		MHz
				10 V	9	0.6		
				15 V	9	0.8		
		C ₁ = 50 pF R ₁ = 5 kΩ R ₂ = ∞ VCO _{IN} = V _{DD} T _C = +25°C	All	5 V	9	0.5		MHz
				10 V	9	1.0		
				15 V	9	1.4		
Source-follower output (demodulated output) offset voltage	VCO _{IN} - V _{DEM} <u>1/</u>	R _S = 10 kΩ T _C = +25°C	All	5 V	1		2.5	V
				10 V	1		2.5	
				15 V	1		2.5	
Output transition time	t _{TLH} , t _{THL} <u>1/</u>	T _C = +25°C	All	5 V	9		200	ns
				10 V	9		100	
				15 V	9		80	

PHASE COMPARATOR SECTION

SIGNAL IN input resistance	R _{SIGIN} <u>1/</u>	T _C = +25°C	All	5 V	1	1.0		MΩ
				10 V	1	0.2		
				15 V	1	0.1		
SIGNAL IN AC coupled voltage sensitivity (peak-to-peak)	V _{SIGIN}	f _{IN} = 100 kHz sine-wave <u>2/</u> T _C = +25°C	All	5 V	4		360	mV
				10 V <u>1/</u>	4		660	
				15 V <u>1/</u>	4		1800	
Quiescent leakage current (phase comparator)	I _{DD1}	SIGNAL IN = open INHIBIT = V _{DD} V _{IN} = 0.0 V or V _{DD} T _C = +25°C and -55°C	All	5 V <u>1/</u>	1, 3		0.2	mA
				10 V <u>1/</u>	1, 3		1.0	
				15 V <u>1/</u>	1, 3		1.5	
				20 V <u>1/</u>	1, 3		4.0	
	I _{DD2}	SIGNAL IN = V _{SS} or V _{DD} INHIBIT = V _{DD} V _{IN} = 0.0 V or V _{DD} T _C = +25°C and -55°C	All	5 V <u>1/</u>	1, 3		20	μA
				10 V <u>1/</u>	1, 3		40	
				15 V <u>1/</u>	1, 3		80	
				20 V <u>1/</u>	1, 3		160	

See footnotes at end of table.

STANDARD MICROCIRCUIT DRAWING DLA LAND AND MARITIME COLUMBUS, OHIO 43218-3990	SIZE A		5962-94664
		REVISION LEVEL C	SHEET 6

TABLE I. Electrical performance characteristics - Continued.

Test	Symbol	Conditions -55°C ≤ T _C ≤ +125°C unless otherwise specified	Device type	V _{DD}	Group A subgroups	Limits		Unit	
						Min	Max		
Three-state leakage current	I _{OUT}	V _{IN} = 0.0 V or 18 V	All	18 V	1, 3		±0.1	μA	
					2		±0.2		
DC coupled signal input and comparator input voltage sensitivity	V _{IL}	V _O = 0.5 V or 4.5 V T _C = +25°C	All	5 V	1		1.5	V	
		V _O = 1.0 V or 9.0 V T _C = +25°C		10 V	1		3.0		
		V _O = 1.5 V or 13.5 V T _C = +25°C		15 V	1		4.0		
	V _{IH}	V _O = 0.5 V or 4.5 V T _C = +25°C	All	5 V	1	3.5		V	
		V _O = 1.0 V or 9.0 V T _C = +25°C		10 V	1	7.0			
		V _O = 1.5 V or 13.5 V T _C = +25°C		15 V	1	11.0			
Propagation delay time, SIGNAL IN to PHASE PULSES	t _{PLH} 1/	See figure 3	All	5 V	9		700	ns	
					10, 11		1050		
				10 V	9		300		
					10, 11		450		
				15 V	9		200		
					10, 11		300		
	t _{PHL} 1/		All	5 V	9		450	ns	
					10, 11		675		
			10 V	9		200			
				10, 11		300			
			15 V	9		130			
				10, 11		195			
Propagation delay time, disable, COMPARATOR IN to PHASE COMPARATOR II OUT	t _{PHZ} 1/	See figure 3	All	5 V	9		450	ns	
					10, 11		675		
				10 V	9		200		
					10, 11		300		
				15 V	9		190		
					10, 11		285		
Propagation delay time, disable, SIGNAL IN to PHASE COMPARATOR II OUT	t _{PLZ} 1/		See figure 3	All	5 V	9		570	ns
						10, 11		855	
					10 V	9		260	
						10, 11		390	
					15 V	9		190	
						10, 11		285	

See footnotes on next sheet.

STANDARD MICROCIRCUIT DRAWING DLA LAND AND MARITIME COLUMBUS, OHIO 43218-3990	SIZE A		5962-94664
		REVISION LEVEL C	SHEET 7

TABLE I. Electrical performance characteristics - Continued.

Test	Symbol	Conditions -55°C ≤ T _C ≤ +125°C unless otherwise specified	Device type	V _{DD}	Group A subgroups	Limits		Unit
						Min	Max	
Input rise or fall time, COMPARATOR IN	t _r , t _f 1/	See figure 3	All	5 V	9		50	μs
					10, 11		75	
				10 V	9		1.0	
					10, 11		1.5	
				15 V	9		0.3	
					10, 11		0.45	
Input rise or fall time, SIGNAL IN	t _r , t _f 1/	See figure 3	All	5 V	9		500	μs
					10, 11		750	
				10 V	9		20	
					10, 11		30	
				15 V	9		2.5	
					10, 11		3.75	
Output transition time	t _{TLH} , t _{THL} 1/	See figure 3	All	5 V	9		200	μs
					10, 11		300	
				10 V	9		100	
					10, 11		150	
				15 V	9		80	
					10, 11		120	

1/ Guaranteed, if not tested, to the limits specified in table I herein.

2/ For sine-wave, the frequency must be greater than 10 kHz for PHASE COMPARATOR II.

STANDARD MICROCIRCUIT DRAWING DLA LAND AND MARITIME COLUMBUS, OHIO 43218-3990	SIZE A		5962-94664
		REVISION LEVEL C	SHEET 8

Device types	01
Case outlines	E
Terminal number	Terminal symbol
1	PHASE PULSES
2	PHASE COMPARATOR I OUT
3	COMPARATOR IN
4	VCO OUT
5	INHIBIT
6	C1(1)
7	C2(2)
8	V _{SS}
9	VCO IN
10	DEMODULATOR OUT
11	R ₁ TO V _{SS}
12	R ₂ TO V _{SS}
13	PHASE COMPARATOR II OUT
14	SIGNAL IN
15	ZENER
16	V _{DD}

FIGURE 1. Terminal connections.

STANDARD MICROCIRCUIT DRAWING DLA LAND AND MARITIME COLUMBUS, OHIO 43218-3990	SIZE A		5962-94664
		REVISION LEVEL C	SHEET 9

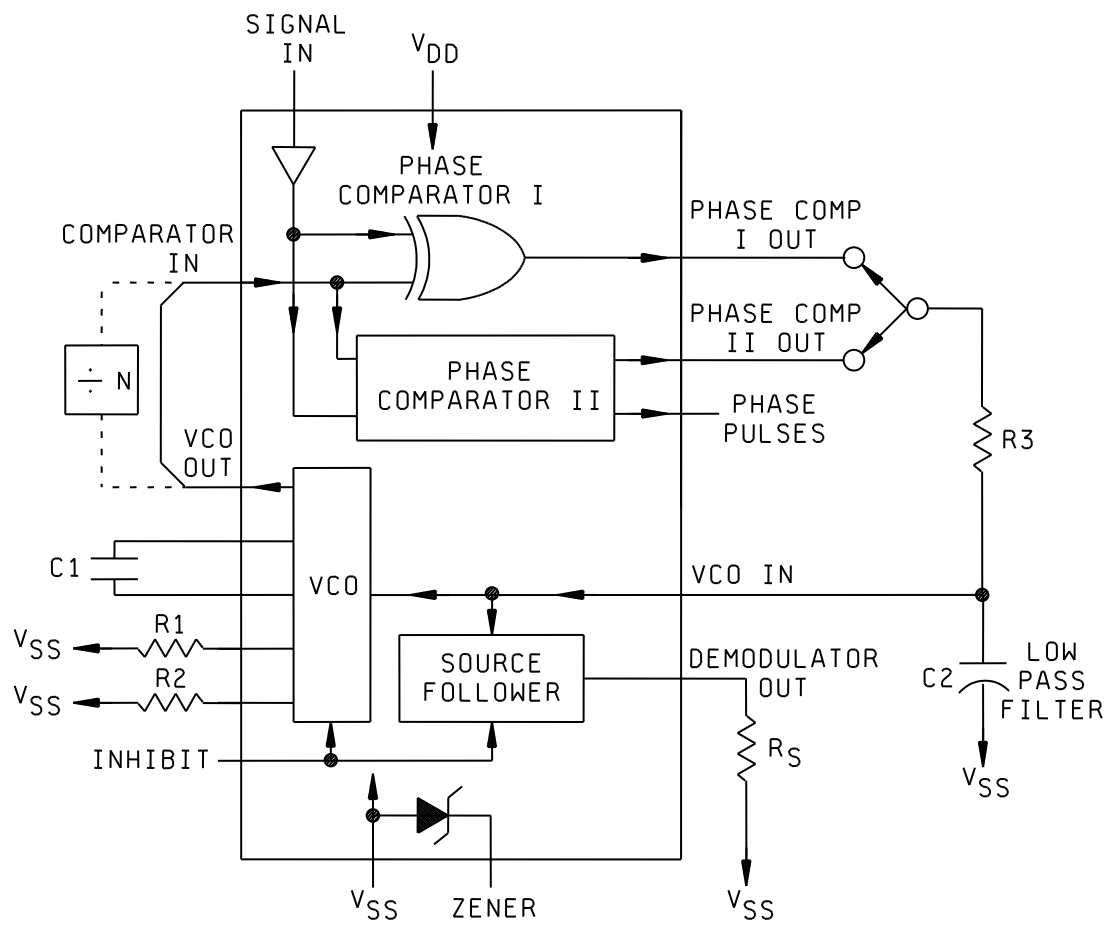

FIGURE 2. Block diagram.

STANDARD MICROCIRCUIT DRAWING DLA LAND AND MARITIME COLUMBUS, OHIO 43218-3990	SIZE A		5962-94664
		REVISION LEVEL C	SHEET 10

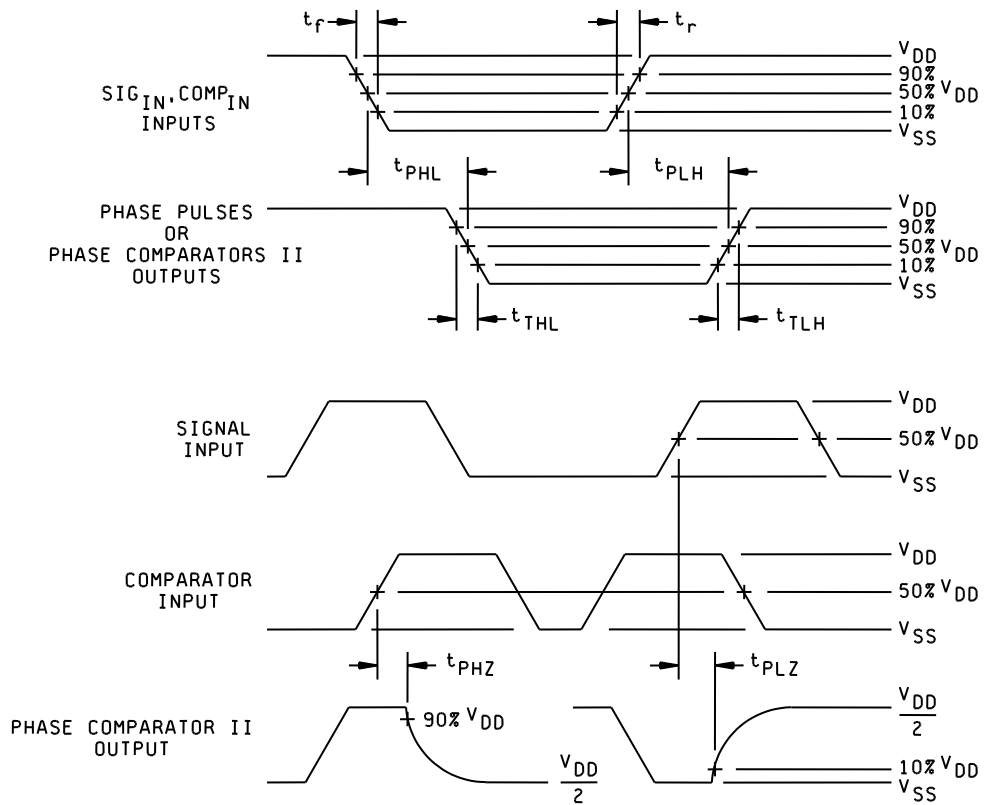
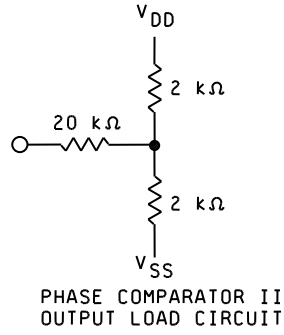

FIGURE 3. Switching waveforms and test circuit.

**STANDARD
MICROCIRCUIT DRAWING**
DLA LAND AND MARITIME
COLUMBUS, OHIO 43218-3990

SIZE
A

5962-94664

REVISION LEVEL
C

SHEET
11

4. VERIFICATION

4.1 Sampling and inspection. For device classes Q and V, sampling and inspection procedures shall be in accordance with MIL-PRF-38535 or as modified in the device manufacturer's Quality Management (QM) plan. The modification in the QM plan shall not affect the form, fit, or function as described herein. For device class M, sampling and inspection procedures shall be in accordance with MIL-PRF-38535, appendix A.

4.2 Screening. For device classes Q and V, screening shall be in accordance with MIL-PRF-38535, and shall be conducted on all devices prior to qualification and technology conformance inspection. For device class M, screening shall be in accordance with method 5004 of MIL-STD-883, and shall be conducted on all devices prior to quality conformance inspection.

4.2.1 Additional criteria for device class M.

- a. Burn-in test, method 1015 of MIL-STD-883.
 - (1) Test condition A, B, C, or D. The test circuit shall be maintained by the manufacturer under document revision level control and shall be made available to the preparing or acquiring activity upon request. The test circuit shall specify the inputs, outputs, biases, and power dissipation, as applicable, in accordance with the intent specified in method 1015.
 - (2) $T_A = +125^{\circ}\text{C}$, minimum.
- b. Interim and final electrical test parameters shall be as specified in table II herein.

4.2.2 Additional criteria for device classes Q and V.

- a. The burn-in test duration, test condition and test temperature, or approved alternatives shall be as specified in the device manufacturer's QM plan in accordance with MIL-PRF-38535. The burn-in test circuit shall be maintained under document revision level control of the device manufacturer's Technology Review Board (TRB) in accordance with MIL-PRF-38535 and shall be made available to the acquiring or preparing activity upon request. The test circuit shall specify the inputs, outputs, biases, and power dissipation, as applicable, in accordance with the intent specified in method 1015 of MIL-STD-883.
- b. Interim and final electrical test parameters shall be as specified in table II herein.
- c. Additional screening for device class V beyond the requirements of device class Q shall be as specified in MIL-PRF-38535, appendix B.

4.3 Qualification inspection for device classes Q and V. Qualification inspection for device classes Q and V shall be in accordance with MIL-PRF-38535. Inspections to be performed shall be those specified in MIL-PRF-38535 and herein for groups A, B, C, D, and E inspections (see 4.4.1 through 4.4.4).

4.4 Conformance inspection. Technology conformance inspection for classes Q and V shall be in accordance with MIL-PRF-38535 including groups A, B, C, D, and E inspections and as specified herein. Quality conformance inspection for device class M shall be in accordance with MIL-PRF-38535, appendix A and as specified herein. Inspections to be performed for device class M shall be those specified in method 5005 of MIL-STD-883 and herein for groups A, B, C, D, and E inspections (see 4.4.1 through 4.4.4).

STANDARD MICROCIRCUIT DRAWING DLA LAND AND MARITIME COLUMBUS, OHIO 43218-3990	SIZE A		5962-94664
		REVISION LEVEL C	SHEET 12

TABLE II. Electrical test requirements.

Test requirements	Subgroups (in accordance with MIL-STD-883, method 5005, table I)	Subgroups (in accordance with MIL-PRF-38535, table III)	
	Device class M	Device class Q	Device class V
Interim electrical parameters (see 4.2)	---	1, 9	1, 9
Final electrical parameters (see 4.2)	<u>1/</u> 1, 2, 3, 7, 9	<u>1/</u> 1, 2, 3, 4, 7, 9	<u>2/</u> 1, 2, 3, 4, 7, 9
Group A test requirements (see 4.4)	1, 2, 3, 4, 7, 9, 10, 11 <u>3/</u>	1, 2, 3, 4, 7, 9, 10, 11 <u>3/</u>	1, 2, 3, 4, 7, 9, 10, 11 <u>3/</u>
Group C end-point electrical parameters (see 4.4)	1, 2, 3	1, 2, 3	1, 2, 3, 4, 7, 9
Group D end-point electrical parameters (see 4.4)	1, 2, 3	1, 2, 3	1, 2, 3
Group E end-point electrical parameters (see 4.4)	1, 7, 9	1, 7, 9	1, 7, 9

1/ PDA applies to subgroup 1.

2/ PDA applies to subgroups 1 and 7.

3/ Subgroups 10 and 11, shall be guaranteed, if not tested, to the limits specified in table I.

4.4.1 Group A inspection.

- a. Tests shall be as specified in table II herein.
- b. Subgroup 7 shall consist of verifying the functionality of the device. These tests form a part of the vendors test program and shall be maintained and available from the approved source of supply.

4.4.2 Group C inspection. The group C inspection end-point electrical parameters shall be as specified in table II herein.

4.4.2.1 Additional criteria for device class M. Steady-state life test conditions, method 1005 of MIL-STD-883:

- a. Test condition A, B, C, or D. The test circuit shall be maintained by the manufacturer under document revision level control and shall be made available to the preparing or acquiring activity upon request. The test circuit shall specify the inputs, outputs, biases, and power dissipation, as applicable, in accordance with the intent specified in method 1005 of MIL-STD-883.
- b. $T_A = +125^\circ\text{C}$, minimum.
- c. Test duration: 1,000 hours, except as permitted by method 1005 of MIL-STD-883.

4.4.2.2 Additional criteria for device classes Q and V. The steady-state life test duration, test condition and test temperature, or approved alternatives shall be as specified in the device manufacturer's QM plan in accordance with MIL-PRF-38535. The test circuit shall be maintained under document revision level control by the device manufacturer's TRB in accordance with MIL-PRF-38535 and shall be made available to the acquiring or preparing activity upon request. The test circuit shall specify the inputs, outputs, biases, and power dissipation, as applicable, in accordance with the intent specified in method 1005 of MIL-STD-883.

STANDARD MICROCIRCUIT DRAWING DLA LAND AND MARITIME COLUMBUS, OHIO 43218-3990	SIZE A		5962-94664
		REVISION LEVEL C	SHEET 13

- 4.4.3 Group D inspection. The group D inspection end-point electrical parameters shall be as specified in table II herein.
- 4.4.4 Group E inspection. Group E inspection is required only for parts intended to be marked as radiation hardness assured (see 3.5 herein).
- a. End-point electrical parameters shall be as specified in table II herein.
 - b. For device classes Q and V, the devices or test vehicle shall be subjected to radiation hardness assured tests as specified in MIL-PRF-38535 for the RHA level being tested. For device class M, the devices shall be subjected to radiation hardness assured tests as specified in MIL-PRF-38535, appendix A for the RHA level being tested. All device classes must meet the postirradiation end-point electrical parameter limits as defined in table I at $T_A = +25^{\circ}\text{C} \pm 5^{\circ}\text{C}$, after exposure, to the subgroups specified in table II herein.

4.5 Methods of inspection. Methods of inspection shall be specified as follows:

4.5.1 Voltage and current. Unless otherwise specified, all voltages given are referenced to the microcircuit GND terminal. Currents given are conventional current and positive when flowing into the referenced terminal.

5. PACKAGING

5.1 Packaging requirements. The requirements for packaging shall be in accordance with MIL-PRF-38535 for device classes Q and V or MIL-PRF-38535, appendix A for device class M.

6. NOTES

6.1 Intended use. Microcircuits conforming to this drawing are intended for use for Government microcircuit applications (original equipment), design applications, and logistics purposes.

6.1.1 Replaceability. Microcircuits covered by this drawing will replace the same generic device covered by a contractor-prepared specification or drawing.

6.1.2 Substitutability. Device class Q devices will replace device class M devices.

6.2 Configuration control of SMD's. All proposed changes to existing SMD's will be coordinated with the users of record for the individual documents. This coordination will be accomplished using DD Form 1692, Engineering Change Proposal.

6.3 Record of users. Military and industrial users should inform DLA Land and Maritime when a system application requires configuration control and which SMD's are applicable to that system. DLA Land and Maritime will maintain a record of users and this list will be used for coordination and distribution of changes to the drawings. Users of drawings covering microelectronic devices (FSC 5962) should contact DLA Land and Maritime-VA, telephone (614) 692-8108.

6.4 Comments. Comments on this drawing should be directed to DLA Land and Maritime-VA, Columbus, Ohio 43218-3990, or telephone (614) 692-0591.

6.5 Abbreviations, symbols, and definitions. The abbreviations, symbols, and definitions used herein are defined in MIL-PRF-38535 and MIL-HDBK-1331.

6.6 Sources of supply.

6.6.1 Sources of supply for device classes Q and V. Sources of supply for device classes Q and V are listed in MIL-HDBK-102 and QML-38535. The vendors listed in MIL-HDBK-103 and QML-38535 have submitted a certificate of compliance (see 3.6 herein) to DLA Land and Maritime-VA and have agreed to this drawing.

6.6.2 Approved sources of supply for device class M. Approved sources of supply for class M are listed in MIL-HDBK-103. The vendors listed in MIL-HDBK-103 have agreed to this drawing and a certificate of compliance (see 3.6 herein) has been submitted to and accepted by DLA Land and Maritime-VA.

STANDARD MICROCIRCUIT DRAWING DLA LAND AND MARITIME COLUMBUS, OHIO 43218-3990	SIZE A		5962-94664
		REVISION LEVEL C	SHEET 14

STANDARD MICROCIRCUIT DRAWING BULLETIN

DATE: 21-02-01

Approved sources of supply for SMD 5962-94664 are listed below for immediate acquisition information only and shall be added to MIL-HDBK-103 and QML-38535 during the next revision. MIL-HDBK-103 and QML-38535 will be revised to include the addition or deletion of sources. The vendors listed below have agreed to this drawing and a certificate of compliance has been submitted to and accepted by DLA Land and Maritime-VA. This information bulletin is superseded by the next dated revision of MIL-HDBK-103 and QML-38535. DLA Land and Maritime maintains an online database of all current sources of supply at <https://landandmaritimeapps.dla.mil/programs/smcr/>.

Standard microcircuit drawing PIN <u>1/</u>	Vendor CAGE number	Vendor similar PIN <u>2/</u>
5962-9466401MEA	01295	CD4046BF3A

1/ The lead finish shown for each PIN representing a hermetic package is the most readily available from the manufacturer listed for that part. If the desired lead finish is not listed, contact the vendor to determine its availability.

2/ Caution. Do not use this number for item acquisition. Items acquired to this number may not satisfy the performance requirements of this drawing.

Vendor CAGE
number

01295

Vendor name
and address

Texas Instruments Inc.
Semiconductor Group
8505 Forest Ln.
P.O. Box 660199
Dallas, TX 75243

The information contained herein is disseminated for convenience only and the Government assumes no liability whatsoever for any inaccuracies in the information bulletin.