

REVISIONS			
LTR	DESCRIPTION	DATE (YR-MO-DA)	APPROVED
A	Update the boilerplate to current requirements as specified in MIL-PRF-38535. – jak	07-05-03	Thomas M. Hess
B	Update output low and high voltage test conditions (V_{OL} and V_{OH}) V_{IH} and V_{IL} limits to table I. Update the boilerplate to current requirements as specified in MIL-PRF-38535. – jwc	14-06-30	Thomas M. Hess
C	Update boilerplate paragraphs to the current MIL-PRF-38535 requirements. - TTM	21-01-25	Muhammad A. Akbar



REV																				
SHEET																				
REV	C	C	C	C	C	C	C	C	C	C	C	C								
SHEET	15	16	17	18	19	20	21	22	23	24	25	26								
REV STATUS				REV	C	C	C	C	C	C	C	C	C	C	C	C	C	C	C	C
OF SHEETS				SHEET	1	2	3	4	5	6	7	8	9	10	11	12	13	14		

PMIC N/A	PREPARED BY Joseph A. Kerby	DLA LAND AND MARITIME COLUMBUS, OHIO 43218-3990 https://www.dla.mil/LandandMaritime		
STANDARD MICROCIRCUIT DRAWING THIS DRAWING IS AVAILABLE FOR USE BY ALL DEPARTMENTS AND AGENCIES OF THE DEPARTMENT OF DEFENSE AMSC N/A	CHECKED BY Thanh V. Nguyen			
	APPROVED BY Monica L. Poelking			
	DRAWING APPROVAL DATE 94-04-22			
	REVISION LEVEL C	MICROCIRCUIT, DIGITAL, ADVANCED BIPOLAR CMOS, SCAN TEST DEVICE, OCTAL BUS TRANSCEIVER AND REGISTER, THREE-STATE OUTPUTS, TTL COMPATIBLE INPUTS, MONOLITHIC SILICON <table border="1"> <tr> <td>SIZE A</td> <td>CAGE CODE 67268</td> <td>5962-94586</td> </tr> </table>	SIZE A	CAGE CODE 67268
SIZE A	CAGE CODE 67268	5962-94586		
		SHEET 1 OF 26		

1. SCOPE

1.1 Scope. This drawing documents two product assurance class levels consisting of high reliability (device classes Q and M) and space application (device class V). A choice of case outlines and lead finishes are available and are reflected in the Part or Identifying Number (PIN). When available, a choice of Radiation Hardness Assurance (RHA) levels is reflected in the PIN.

1.2 PIN. The PIN is as shown in the following example:

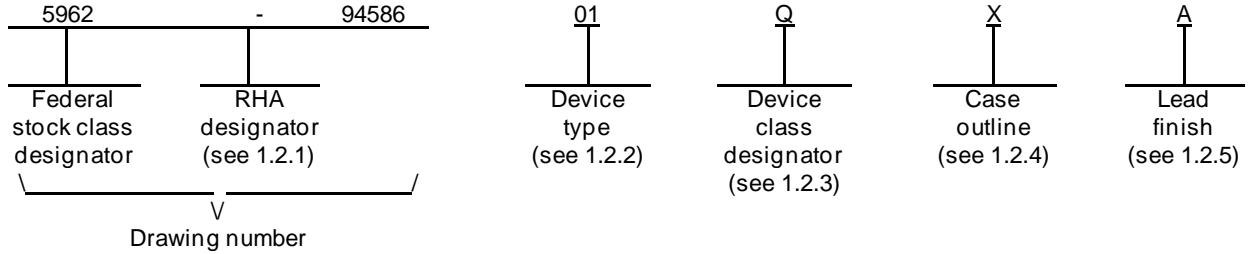

1.2.1 RHA designator. Device classes Q and V RHA marked devices meet the MIL-PRF-38535 specified RHA levels and are marked with the appropriate RHA designator. Device class M RHA marked devices meet the MIL-PRF-38535, appendix A specified RHA levels and are marked with the appropriate RHA designator. A dash (-) indicates a non-RHA device.

1.2.2 Device type(s). The device type(s) identify the circuit function as follows:

<u>Device type</u>	<u>Generic number</u>	<u>Circuit function</u>
01	54ABT8646	Scan test device with octal bus transceiver and register, three-state outputs, TTL compatible inputs

1.2.3 Device class designator. The device class designator is a single letter identifying the product assurance level as follows:

<u>Device class</u>	<u>Device requirements documentation</u>
M	Vendor self-certification to the requirements for MIL-STD-883 compliant, non-JAN class level B microcircuits in accordance with MIL-PRF-38535, appendix A
Q or V	Certification and qualification to MIL-PRF-38535

1.2.4 Case outline(s). The case outline(s) are as designated in MIL-STD-1835 and as follows:

<u>Outline letter</u>	<u>Descriptive designator</u>	<u>Terminals</u>	<u>Package style</u>
X	GDIP3-T28 or CDIP4-T28	28	Dual-in-line
3	CQCC1-N28	28	Square leadless chip carrier

1.2.5 Lead finish. The lead finish is as specified in MIL-PRF-38535 for device classes Q, and V or MIL-PRF-38535, appendix A for device class M.

STANDARD MICROCIRCUIT DRAWING DLA LAND AND MARITIME COLUMBUS, OHIO 43218-3990	SIZE A		5962-94586
		REVISION LEVEL C	SHEET 2

1.3 Absolute maximum ratings. 1/ 2/ 3/

Supply voltage range (V_{CC})	-0.5 V dc to +7.0 V dc
DC input voltage range (I/O ports) (V_{IN}).....	-0.5 V dc to +5.5 V dc <u>4/</u>
DC input voltage range (except I/O ports) (V_{IN}).....	-0.5 V dc to +7.0 V dc <u>4/</u>
DC output voltage range (V_{OUT})	-0.5 V dc to +5.5 V dc <u>4/</u>
DC output current (I_{OL}) (per output).....	+96 mA
DC input clamp current (I_{IK}) ($V_{IN} < 0.0$ V)	-18 mA
DC output clamp current (I_{OK}) ($V_{OUT} < 0.0$ V)	-50 mA
Storage temperature range (T_{STG}).....	-65°C to +150°C
Lead temperature (soldering, 10 seconds)	+300°C
Thermal resistance, junction-to-case (θ_{JC}).....	See MIL-STD-1835
Junction temperature (T_J)	+175°C
Maximum power dissipation (P_D)	420 mW <u>5/</u>

1.4 Recommended operating conditions. 2/ 3/

Supply voltage range (V_{CC})	+4.5 V dc to +5.5 V dc
Input voltage range (V_{IN})	+0.0 V dc to V_{CC}
Output voltage range (V_{OUT})	+0.0 V dc to V_{CC}
Maximum low level input voltage (V_{IL})	0.8 V
Minimum high level input voltage (V_{IH}).....	2.0 V
Maximum high level output current (I_{OH}).....	-24 mA
Maximum low level output current (I_{OL}).....	+48 mA
Maximum input rise or fall rate ($\Delta t/\Delta V$).....	10 ns/V
Minimum setup time (t_s):	
An before CLKAB \uparrow or Bn before CLKBA \uparrow	4.7 ns
An, Bn, CLKAB, CLKBA, DIR OE, SAB, OR SBA before TCK \uparrow	7.0 ns
TDI or TMS before TCK \uparrow	6.0 ns
Minimum hold time (t_h):	
An before CLKAB \uparrow or Bn after CLKBA \uparrow	0.0 ns
An, Bn, CLKAB, CLKBA, DIR OE, SAB, OR SBA after TCK \uparrow	0.0 ns
TDI or TMS after TCK \uparrow	0.0 ns
Minimum pulse width, TCK high or low (t_w).....	5.0 ns
Minimum pulse width, CLKAB or CLKBA high or low (t_w).....	3.0 ns
Minimum delay time, power-up to TCK \uparrow (t_d).....	50.0 ns <u>6/</u>
Minimum rise time, V_{CC} power-up (t_r).....	1 μ s <u>6/</u>
Maximum TCK frequency (f_{CLK}).....	50 MHz
Case operating temperature range (T_C).....	-55°C to +125°C

- 1/ Stresses above the absolute maximum rating may cause permanent damage to the device. Extended operation at the maximum levels may degrade performance and affect reliability.
- 2/ Unless otherwise noted, all voltages are referenced to GND.
- 3/ The limits for the parameters specified herein shall apply over the full specified V_{CC} range and case temperature range of -55°C to +125°C.
- 4/ The input and output negative voltage ratings may be exceeded provided that the input and output clamp current ratings are observed.
- 5/ Power dissipation values are derived using the formula $P_D = V_{CC}I_{CC} + nV_{OL}I_{OL}$, where V_{CC} and I_{OL} are as specified in 1.4 herein, I_{CC} and V_{OL} are as specified in table I herein, and n represents the total number of outputs.
- 6/ This parameter is not production tested.

STANDARD MICROCIRCUIT DRAWING DLA LAND AND MARITIME COLUMBUS, OHIO 43218-3990	SIZE A		5962-94586
		REVISION LEVEL C	SHEET 3

2. APPLICABLE DOCUMENTS

2.1 Government specification, standards, and handbooks. The following specification, standards, and handbooks form a part of this drawing to the extent specified herein. Unless otherwise specified, the issues of these documents are those cited in the solicitation or contract.

DEPARTMENT OF DEFENSE SPECIFICATION

MIL-PRF-38535 - Integrated Circuits, Manufacturing, General Specification for.

DEPARTMENT OF DEFENSE STANDARDS

MIL-STD-883 - Test Method Standard Microcircuits.
 MIL-STD-1835 - Interface Standard Electronic Component Case Outlines.

DEPARTMENT OF DEFENSE HANDBOOKS

MIL-HDBK-103 - List of Standard Microcircuit Drawings.
 MIL-HDBK-780 - Standard Microcircuit Drawings.

(Copies of these documents are available online at <https://quicksearch.dla.mil/>)

2.2 Non-Government publications. The following document(s) form a part of this document to the extent specified herein. Unless otherwise specified, the issues of these documents are those cited in the solicitation or contract.

IEEE – THE INSTITUTE OF ELECTRICAL AND ELECTRONICS ENGINEERS (IEEE)

IEEE 1149.1 - IEEE Standard Test Access Port and Boundary Scan Architecture.

(Copies of these documents are available online at <https://standards.ieee.org/standard/index.html>)

(Non-Government standards and other publications are normally available from the organizations that prepare or distribute the documents. These documents may also be available in or through libraries or other informational services.)

2.3 Order of precedence. In the event of a conflict between the text of this drawing and the references cited herein, the text of this drawing takes precedence. Nothing in this document, however, supersedes applicable laws and regulations unless a specific exemption has been obtained.

3. REQUIREMENTS

3.1 Item requirements. The individual item requirements for device classes Q and V shall be in accordance with MIL-PRF-38535 and as specified herein or as modified in the device manufacturer's Quality Management (QM) plan. The modification in the QM plan shall not affect the form, fit, or function as described herein. The individual item requirements for device class M shall be in accordance with MIL-PRF-38535, appendix A for non-JAN class level B devices and as specified herein.

3.2 Design, construction, and physical dimensions. The design, construction, and physical dimensions shall be as specified in MIL-PRF-38535 and herein for device classes Q and V or MIL-PRF-38535, appendix A and herein for device class M.

3.2.1 Case outlines. The case outlines shall be in accordance with 1.2.4 herein.

3.2.2 Terminal connections. The terminal connections shall be as specified on figure 1.

3.2.3 Truth table. The truth table shall be as specified on figure 2.

3.2.4 Block diagram. The block diagram shall be as specified on figure 3.

3.2.5 Test access port controller and scan test registers. The test access port controller and scan test registers shall be as specified on figure 4.

STANDARD MICROCIRCUIT DRAWING DLA LAND AND MARITIME COLUMBUS, OHIO 43218-3990	SIZE A		5962-94586
		REVISION LEVEL C	SHEET 4

3.2.6 Ground bounce waveforms and test circuit. The ground bounce waveforms and test circuit shall be as specified on figure 5.

3.2.7 Switching waveforms and test circuit. The switching waveforms and test circuit shall be as specified on figure 6.

3.3 Electrical performance characteristics and postirradiation parameter limits. Unless otherwise specified herein, the electrical performance characteristics and postirradiation parameter limits are as specified in table I and shall apply over the full case operating temperature range.

3.4 Electrical test requirements. The electrical test requirements shall be the subgroups specified in table II. The electrical tests for each subgroup are defined in table I.

3.5 Marking. The part shall be marked with the PIN listed in 1.2 herein. In addition, the manufacturer's PIN may also be marked. For packages where marking of the entire SMD PIN number is not feasible due to space limitations, the manufacturer has the option of not marking the "5962-" on the device. For RHA product using this option, the RHA designator shall still be marked. Marking for device classes Q and V shall be in accordance with MIL-PRF-38535. Marking for device class M shall be in accordance with MIL-PRF-38535, appendix A.

3.5.1 Certification/compliance mark. The certification mark for device classes Q and V shall be a "QML" or "Q" as required in MIL-PRF-38535. The compliance mark for device class M shall be a "C" as required in MIL-PRF-38535, appendix A.

3.6 Certificate of compliance. For device classes Q and V, a certificate of compliance shall be required from a QML-38535 listed manufacturer in order to supply to the requirements of this drawing (see 6.6.1 herein). For device class M, a certificate of compliance shall be required from a manufacturer in order to be listed as an approved source of supply in MIL-HDBK-103 (see 6.6.2 herein). The certificate of compliance submitted to DLA Land and Maritime-VA prior to listing as an approved source of supply for this drawing shall affirm that the manufacturer's product meets, for device classes Q and V, the requirements of MIL-PRF-38535 and herein or for device class M, the requirements of MIL-PRF-38535, appendix A and herein.

3.7 Certificate of conformance. A certificate of conformance as required for device classes Q and V in MIL-PRF-38535 or for device class M in MIL-PRF-38535, appendix A shall be provided with each lot of microcircuits delivered to this drawing.

3.8 Notification of change for device class M. For device class M, notification to DLA Land and Maritime-VA of change of product (see 6.2 herein) involving devices acquired to this drawing is required for any change that affects this drawing.

3.9 Verification and review for device class M. For device class M, DLA Land and Maritime, DLA Land and Maritime's agent, and the acquiring activity retain the option to review the manufacturer's facility and applicable required documentation. Offshore documentation shall be made available onshore at the option of the reviewer.

3.10 Microcircuit group assignment for device class M. Device class M devices covered by this drawing shall be in microcircuit group number 126 (see MIL-PRF-38535, appendix A).

3.11 IEEE 1140.1 compliance. The device shall be compliant with IEEE 1149.1.

STANDARD MICROCIRCUIT DRAWING DLA LAND AND MARITIME COLUMBUS, OHIO 43218-3990	SIZE A		5962-94586
		REVISION LEVEL C	SHEET 5

TABLE I. Electrical performance characteristics.

Test and MIL-STD-883 test method <u>1/</u>	Symbol	Test conditions <u>2/</u> -55°C ≤ T _C ≤ +125°C +4.5 V ≤ V _{CC} ≤ +5.5 V unless otherwise specified		V _{CC}	Group A subgroups	Limits <u>3/</u>		Unit
						Min	Max	
High level output voltage 3006	V _{OH}	For all inputs affecting output under test, V _{IN} = V _{IH} or V _{IL} V _{IL} = 0.8 V V _{IH} = 2.0 V	I _{OH} = -3 mA	4.5 V	1, 2, 3	2.5		V
				5.0 V	1, 2, 3	3.0		V
			I _{OH} = -24 mA	4.5 V	1, 2, 3	2.0		V
Low level output voltage 3007	V _{OL}	For all inputs affecting output under test, V _{IN} = V _{IH} or V _{IL} V _{IL} = 0.8 V, V _{IH} = 2.0 V I _{OL} = 48 mA		4.5 V	1, 2, 3		0.55	V
Negative input clamp voltage 3022	V _{IC-}	For input under test, I _{IN} = -18 mA		4.5 V	1, 2, 3		-1.2	V
Input current high 3010	I _{IH} <u>4/</u>	For input under test, V _{IN} = V _{CC}	CLK, DIR, $\overline{\text{OE}}$, S, TCK	4.5 V	1, 2, 3		+1.0	μA
			A or B ports	4.5 V	1, 2, 3		+100	
			TDI, TMS	4.5 V	1, 2, 3		+10.0	
Input current low 3009	I _{IL} <u>4/</u>	For input under test, V _{IN} = GND	CLK, DIR, $\overline{\text{OE}}$, S, TCK	4.5 V	1, 2, 3		-1.0	μA
			A or B ports	4.5 V	1, 2, 3		-100	
			TDI, TMS	4.5 V	1, 2, 3		-160	
Three-state output leakage current high 3021	I _{OZH} <u>5/</u>	For control input affecting output under test, V _{IN} = V _{IH} or V _{IL} V _{IL} = 0.8 V, V _{IH} = 2.0 V V _{OUT} = 2.7 V		5.5 V	1, 2, 3		50.0	μA
Three-state output leakage current low 3020	I _{OZL} <u>5/</u>	For control input affecting output under test, V _{IN} = V _{IH} or V _{IL} V _{IL} = 0.8 V, V _{IH} = 2.0 V		5.5 V	1, 2, 3		-50.0	μA
Off-state leakage current	I _{OFF}	For input or output under test, V _{IN} or V _{OUT} = 5.5 V All other pins at 0.0 V		0.0 V	1		±100	μA
High-state leakage current	I _{CEX}	For output under test, V _{OUT} = 5.5 V Outputs at high logic state		5.5 V	1, 2, 3		50	μA
Output current 3011	I _O <u>6/</u>	V _{OUT} = 2.5 V		5.5 V	1, 2, 3	-50	-180	mA

See footnotes at end of table.

STANDARD MICROCIRCUIT DRAWING DLA LAND AND MARITIME COLUMBUS, OHIO 43218-3990	SIZE A		5962-94586
		REVISION LEVEL C	SHEET 6

TABLE I. Electrical performance characteristics – Continued.

Test and MIL-STD-883 test method <u>1/</u>	Symbol	Test conditions <u>2/</u> -55°C ≤ T _C ≤ +125°C +4.5 V ≤ V _{CC} ≤ +5.5 V unless otherwise specified		V _{CC}	Group A subgroups	Limits <u>3/</u>		Unit
						Min	Max	
Quiescent supply current delta, output high 3005	ΔI_{CC} <u>7/</u>	For input under test, V _{IN} = 3.4 V For all other inputs, V _{IN} = V _{CC} or GND		5.5 V	1, 2, 3		1.5	mA
Quiescent supply current, outputs high 3005	I _{CCH}	For all inputs, V _{IN} = V _{CC} or GND I _{OUT} = 0 A A or B ports		5.5 V	1, 2, 3		2.0	mA
Quiescent supply current, outputs low 3005	I _{CCL}			5.5 V	1, 2, 3		38	mA
Quiescent supply current, outputs disabled 3005	I _{CCZ}			5.5 V	1, 2, 3		2.0	mA
Input capacitance 3012	C _{IN}	T _C = +25°C See 4.4.1c	Control inputs	5.0 V	4		15.3	pF
Input/output capacitance 3012	C _{I/O}		A or B ports	5.0 V	4		24.9	pF
Output capacitance 3012	C _{OUT}		TDO	5.0 V	4		24.2	pF
Low level ground bounce noise	V _{OLP} <u>8/</u>	V _{IH} = 3.0 V V _{IL} = 0.0 V T _A = +25°C See 4.4.1d See figure 5		5.0 V	4		1500	mV
	V _{OLV} <u>8/</u>			5.0 V	4		-1000	mV
High level V _{CC} bounce noise	V _{OHP} <u>8/</u>			5.0 V	4		1600	mV
	V _{OHV} <u>8/</u>			5.0 V	4		-550	mV
Functional tests 3014	<u>9/</u>			V _{IL} = 0.8 V, V _{IH} = 2.0 V Verify output V _O See 4.4.1b		4.5 V	7, 8	L
		5.5 V	7, 8			L	H	
NORMAL MODE								
Propagation delay time, A _n to B _n or B _n to A _n 3003	t _{PLH1}	C _L = 50 pF minimum R _L = 500 Ω See figure 6		5.0 V	9	2.0	4.5	ns
				4.5 V and 5.5 V	10, 11	2.0	5.5	
	t _{PHL1}			5.0 V	9	2.0	4.6	ns
				4.5 V and 5.5 V	10, 11	2.0	5.8	

See foot notes at end of table.

STANDARD MICROCIRCUIT DRAWING DLA LAND AND MARITIME COLUMBUS, OHIO 43218-3990	SIZE A		5962-94586
		REVISION LEVEL C	SHEET 7

TABLE I. Electrical performance characteristics – Continued.

Test and MIL-STD-883 test method <u>1/</u>	Symbol	Test conditions <u>2/</u> -55°C ≤ T _C ≤ +125°C +4.5 V ≤ V _{CC} ≤ +5.5 V unless otherwise specified	V _{CC}	Group A subgroups	Limits <u>3/</u>		Unit
					Min	Max	
Propagation delay time, CLKAB to Bn or CLKBA to An 3003	t _{PLH2}	C _L = 50 pF minimum R _L = 500 Ω See figure 6	5.0 V	9	3.0	5.3	ns
			4.5 V and 5.5 V	10, 11	3.0	6.3	
	t _{PHL2}		5.0 V	9	2.5	5.2	ns
			4.5 V and 5.5 V	10, 11	2.5	6.7	
Propagation delay time, SAB to Bn or SBA to An 3003	t _{PLH3}		5.0 V	9	2.0	6.0	ns
			4.5 V and 5.5 V	10, 11	2.0	7.5	
	t _{PHL3}		5.0 V	9	2.0	5.9	ns
			4.5 V and 5.5 V	10, 11	2.5	7.8	
Propagation delay time, output enable, DIR to Bn or An 3003	t _{PZH1}		5.0 V	9	2.5	5.4	ns
			4.5 V and 5.5 V	10, 11	2.5	6.6	
	t _{PZL1}		5.0 V	9	3.0	6.2	ns
			4.5 V and 5.5 V	10, 11	3.0	8.1	
Propagation delay time, <u>o</u> utput enable, OE to Bn or An 3003	t _{PZH2}		5.0 V	9	2.5	5.4	ns
			4.5 V and 5.5 V	10, 11	2.5	6.7	
	t _{PZL2}		5.0 V	9	3.0	6.2	ns
			4.5 V and 5.5 V	10, 11	3.0	7.6	
Propagation delay time, output disable, DIR to Bn or An 3003	t _{PHZ1}		5.0 V	9	3.0	7.9	ns
			4.5 V and 5.5 V	10, 11	3.0	8.9	
	t _{PLZ1}		5.0 V	9	3.0	6.6	ns
			4.5 V and 5.5 V	10, 11	3.0	8.1	

See footnotes at end of table.

STANDARD MICROCIRCUIT DRAWING DLA LAND AND MARITIME COLUMBUS, OHIO 43218-3990	SIZE A		5962-94586
		REVISION LEVEL C	SHEET 8

TABLE I. Electrical performance characteristics – Continued.

Test and MIL-STD-883 test method <u>1/</u>	Symbol	Test conditions <u>2/</u> -55°C ≤ T _C ≤ +125°C +4.5 V ≤ V _{CC} ≤ +5.5 V unless otherwise specified	V _{CC}	Group A subgroups	Limits <u>3/</u>		Unit
					Min	Max	
Propagation delay time, output disable, OE to An or Bn 3003	t _{PHZ2}	C _L = 50 pF minimum R _L = 500 Ω See figure 6	5.0 V	9	2.0	7.7	ns
			4.5 V and 5.5 V	10, 11	2.8	8.6	
	t _{PLZ2}		5.0 V	9	3.0	6.2	ns
			4.5 V and 5.5 V	10, 11	3.0	8.3	
Maximum CLKAB or CLKBA frequency	f _{MAX1}	4.5 V	9	100		MHz	
			10, 11	100			
TEST MODE							
Propagation delay time, TCK↓ to An or Bn 3003	t _{PLH4}	C _L = 50 pF minimum R _L = 500 Ω See figure 6	5.0 V	9	3.5	9.5	ns
			4.5 V and 5.5 V	10, 11	3.5	13.4	
	t _{PHL4}		5.0 V	9	3.0	10.0	ns
			4.5 V and 5.5 V	10, 11	3.0	12.0	
Propagation delay time, TCK↓ to TDO 3003	t _{PLH5}	C _L = 50 pF minimum R _L = 500 Ω See figure 6	5.0 V	9	2.5	5.5	ns
			4.5 V and 5.5 V	10, 11	2.5	7.0	
	t _{PHL5}		5.0 V	9	2.5	5.5	ns
			4.5 V and 5.5 V	10, 11	2.5	7.0	
Propagation delay time, output enable, TCK↓ to An or Bn 3003	t _{PZH3}	C _L = 50 pF minimum R _L = 500 Ω See figure 6	5.0 V	9	4.5	9.7	ns
			4.5 V and 5.5 V	10, 11	4.5	12.5	
	t _{PZL3}		5.0 V	9	4.5	11.2	ns
			4.5 V and 5.5 V	10, 11	4.5	13.5	

See footnotes at end of table.

STANDARD MICROCIRCUIT DRAWING DLA LAND AND MARITIME COLUMBUS, OHIO 43218-3990	SIZE A		5962-94586
		REVISION LEVEL C	SHEET 9

TABLE I. Electrical performance characteristics – Continued.

Test and MIL-STD-883 test method ^{1/}	Symbol	Test conditions ^{2/} -55°C ≤ T _C ≤ +125°C +4.5 V ≤ V _{CC} ≤ +5.5 V unless otherwise specified	V _{CC}	Group A subgroups	Limits ^{3/}		Unit
					Min	Max	
Propagation delay time, output enable, TCK↓ to TDO 3003	t _{PZH4}	C _L = 50 pF minimum R _L = 500 Ω See figure 6	5.0 V	9	2.5	5.5	ns
			4.5 V and 5.5 V	10, 11	2.5	7.0	
	t _{PZL4}		5.0 V	9	2.5	6.0	ns
			4.5 V and 5.5 V	10, 11	2.5	7.5	
Propagation delay time, output disable, TCK↓ to An or Bn 3003	t _{PHZ3}		5.0 V	9	3.5	13.0	ns
			4.5 V and 5.5 V	10, 11	3.5	14.5	
	t _{PLZ3}		5.0 V	9	3.0	10.5	ns
			4.5 V and 5.5 V	10, 11	3.0	13.5	
Propagation delay time, output disable, TCK↓ to TDO 3003	t _{PHZ4}		5.0 V	9	3.0	7.0	ns
			4.5 V and 5.5 V	10, 11	3.0	9.0	
	t _{PLZ4}		5.0 V	9	3.0	6.5	ns
			4.5 V and 5.5 V	10, 11	3.0	8.0	
Maximum TCK frequency	f _{MAX2}		4.5 V	9	50	MHz	
				10, 11	50		

- ^{1/} For tests not listed in the referenced MIL-STD-883 (e.g. ΔI_{CC}), utilize the general test procedure under the conditions listed herein.
- ^{2/} Each input/output, as applicable, shall be tested at the specified temperature, for the specified limits, to the tests in table I herein. Output terminals not designated shall be high level logic, low level logic, or open, except for all I_{CC} and ΔI_{CC} tests where the output terminals shall be open. When performing these tests, the current meter shall be placed in the circuit such that all current flows through the meter. For input terminals not designated, V_{IN} = GND or V_{IN} ≥ 3.0 V.
- ^{3/} For negative and positive voltage and current values, the sign designates the potential difference in reference to GND and the direction of current flow, respectively; and the absolute value of the magnitude, not the sign, is relative to the minimum and maximum limits, as applicable, listed herein. Devices shall meet or exceed the limits specified in table I if tested at 4.5 V ≤ V_{CC} ≤ 5.5 V.
- ^{4/} For I/O ports, the limit includes I_{OZH} or I_{OZL} leakage current from the output circuitry.
- ^{5/} For I/O ports, the limit includes I_{IH} or I_{IL} leakage current from the input circuitry.

STANDARD MICROCIRCUIT DRAWING DLA LAND AND MARITIME COLUMBUS, OHIO 43218-3990	SIZE A		5962-94586
		REVISION LEVEL C	SHEET 10

TABLE I. Electrical performance characteristics – Continued.

- 6/ Not more than one output should be tested at one time, and the duration of the test condition should not exceed one second.
- 7/ This is the increase in supply current for each input that is at one of the specific TTL voltage levels rather than 0 V or V_{CC} . This test may be performed either one input at a time (preferred method) or with all input pins simultaneously at $V_{IN} = V_{CC} - 2.1$ V (alternate method). When the test is performed using the alternate test method, the maximum limits is equal to the number of inputs at a high TTL input level times 1.5 mA, and the preferred method and limits are guaranteed.
- 8/ This test is for qualification only. Ground and V_{CC} bounce tests are performed on a non-switching (quiescent) output and are used to measure the magnitude of induced noise caused by other simultaneously switching outputs. The test is performed on a low noise bench test fixture. For the device under test, all outputs shall be loaded with 500Ω of load resistance and a minimum of 50 pF of load capacitance (see figure 5). Only chip capacitors and resistors shall be used. The output load components shall be located as close as possible to the device outputs. It is suggested that, whenever possible, this distance be kept to less than 0.25 inches. Decoupling capacitors shall be placed in parallel from V_{CC} to ground. The device manufacturer shall determine the values of these decoupling capacitors. The low and high level ground and V_{CC} bounce noise is measured at the quiet output using a 1 GHz minimum bandwidth oscilloscope with a 50Ω input impedance.

The device inputs shall be conditioned such that all outputs are at a high nominal V_{OH} level. The device inputs shall then be conditioned such that they switch simultaneously and the output under test remains at V_{OH} as all other outputs possible are switched from V_{OH} to V_{OL} . V_{OHV} and V_{OHP} are then measured from the nominal V_{OH} level to the largest negative and positive peaks, respectively (see figure 5). This is then repeated with the same outputs not under test switching from V_{OL} to V_{OH} .

The device inputs shall be conditioned such that all outputs are at a low nominal V_{OL} level. The device inputs shall then be conditioned such that they switch simultaneously and the output under test remains at V_{OL} as all other outputs possible are switched from V_{OL} to V_{OH} . V_{OLP} and V_{OLV} are then measured from the nominal V_{OL} level to the largest positive and negative peaks, respectively (see figure 5). This is then repeated with the same outputs not under test switching from V_{OH} to V_{OL} .

- 9/ Tests shall be performed in sequence, attributes data only. Functional tests shall include the truth table and other logic patterns used for fault detection. The test vectors used to verify the truth table shall, at a minimum, test all functions of each input and output. All possible input to output logic patterns per function shall be guaranteed, if not tested, to the truth table in figure 2 herein. Functional tests shall be performed in sequence as approved by the qualifying activity in qualified devices. After incorporating allowable tolerances per MIL-STD-883, $V_{IL} = 0.4$ V and $V_{IH} = 2.4$ V. For outputs $L \leq 0.8$ V, $H \geq 2.0$ V.

STANDARD MICROCIRCUIT DRAWING DLA LAND AND MARITIME COLUMBUS, OHIO 43218-3990	SIZE A		5962-94586
		REVISION LEVEL C	SHEET 11

Device type	01	
Case outlines	X	3
Terminal number	Terminal symbol	
1	CLKAB	B4
2	SAB	B3
3	DIR	B2
4	A1	<u>B1</u>
5	A2	<u>OE</u>
6	A3	SBA
7	GND	CLKBA
8	A4	CLKAB
9	A5	SAB
10	A6	DIR
11	A7	A1
12	A8	A2
13	TDO	A3
14	TMS	GND
15	TCK	A4
16	TDI	A5
17	B8	A6
18	B7	A7
19	B6	A8
20	B5	TDO
21	V _{cc}	TMS
22	B4	TCK
23	B3	TDI
24	B2	B8
25	<u>B1</u>	B7
26	<u>OE</u>	B6
27	SBA	B5
28	CLKBA	V _{cc}

Terminal descriptions	
Terminal symbol	Description
An (n = 1 to 8)	Data inputs/outputs, A port
Bn (n = 1 to 8)	Data inputs/outputs, B port
<u>OE</u>	Output enable control input
DIR	Direction control input
SAB, SBA	Output data source select inputs
CLKAB, CLKBA	Directional clock pulse timing inputs
TDI	Test data input
TDO	Test data output
TMS	Test mode select input
TCK	Test clock input

FIGURE 1. Terminal connections.

STANDARD MICROCIRCUIT DRAWING DLA LAND AND MARITIME COLUMBUS, OHIO 43218-3990	SIZE A		5962-94586
		REVISION LEVEL C	SHEET 12

Inputs						Data I/Os		Operation
\overline{OE}	DIR	CLKAB	CLKBA	SAB	SBA	An	Bn	
X	X	↑	X	X	X	Input	Unspecified <u>1/</u>	Store A, B unspecified <u>1/</u>
X	X	X	↑	X	X	Unspecified <u>1/</u>	Input	Store B, A unspecified <u>1/</u>
H	X	↑	↑	X	X	Input	Input	Store A and B data
H	X	H or L	H or L	X	X	Input disabled	Input disabled	Isolation, hold storage
L	L	X	X	X	L	Output	Input	Real-time B data to A bus
L	L	X	H or L	X	H	Output	Input disabled	Stored B data to A bus
L	H	X	X	L	X	Input	Output	Real-time A data to B bus
L	H	H or L	X	H	X	Input disabled	Output	Stored A data to B bus

1/ The data output functions can be enabled or disabled by various signals at the \overline{OE} and DIR inputs. Data input functions are always enabled; i.e., data at the bus pins will be stored on every low-to-high transition of the clock inputs.

H = High voltage level
L = Low voltage level
X = Irrelevant
↑ = Low-to-high transition

FIGURE 2. Truth table.

STANDARD MICROCIRCUIT DRAWING DLA LAND AND MARITIME COLUMBUS, OHIO 43218-3990	SIZE A		5962-94586
		REVISION LEVEL C	SHEET 13

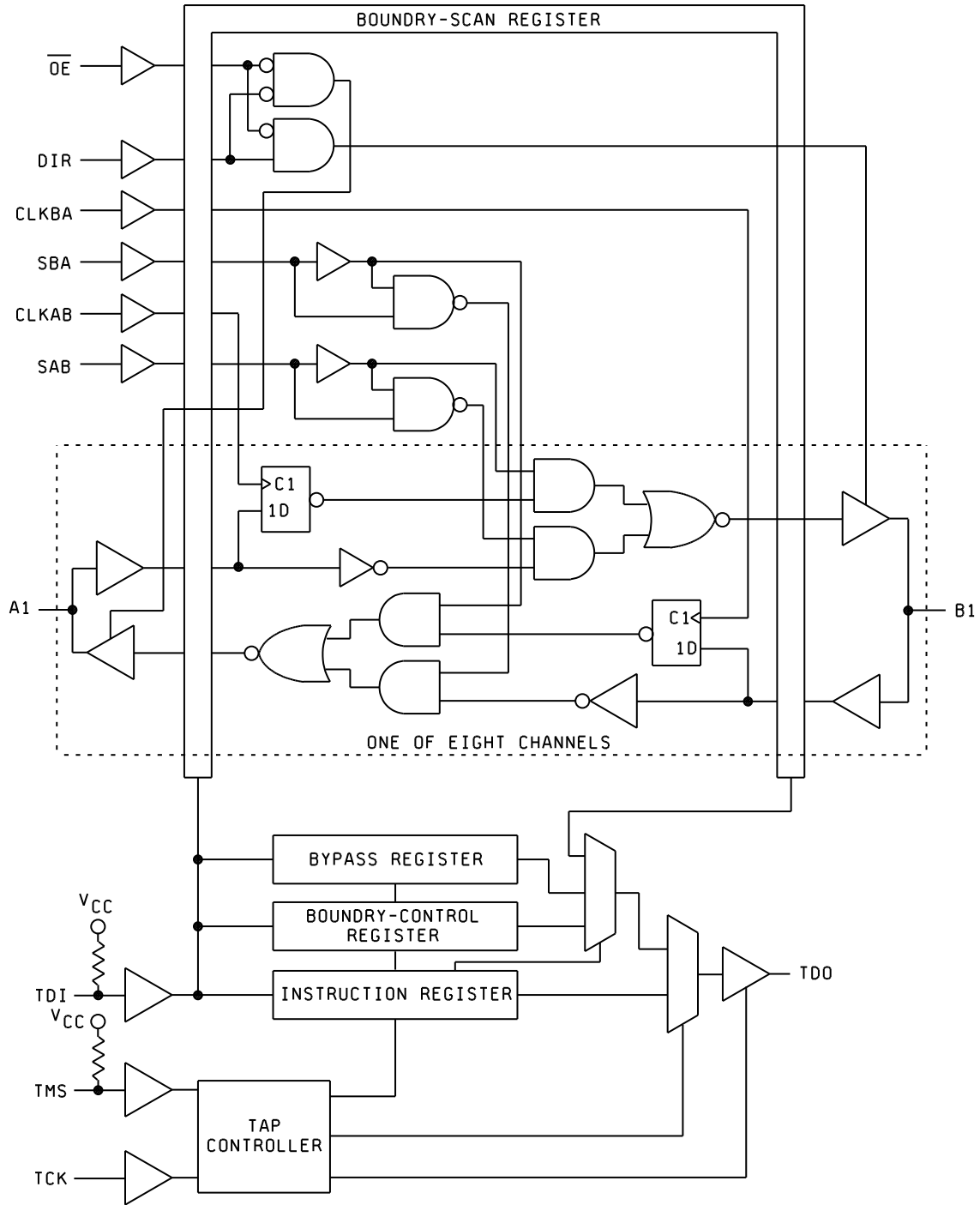

FIGURE 3. Block diagram.

**STANDARD
MICROCIRCUIT DRAWING**
DLA LAND AND MARITIME
COLUMBUS, OHIO 43218-3990

SIZE
A

5962-94586

REVISION LEVEL
C

SHEET
14

Test access port (TAP) controller state diagram

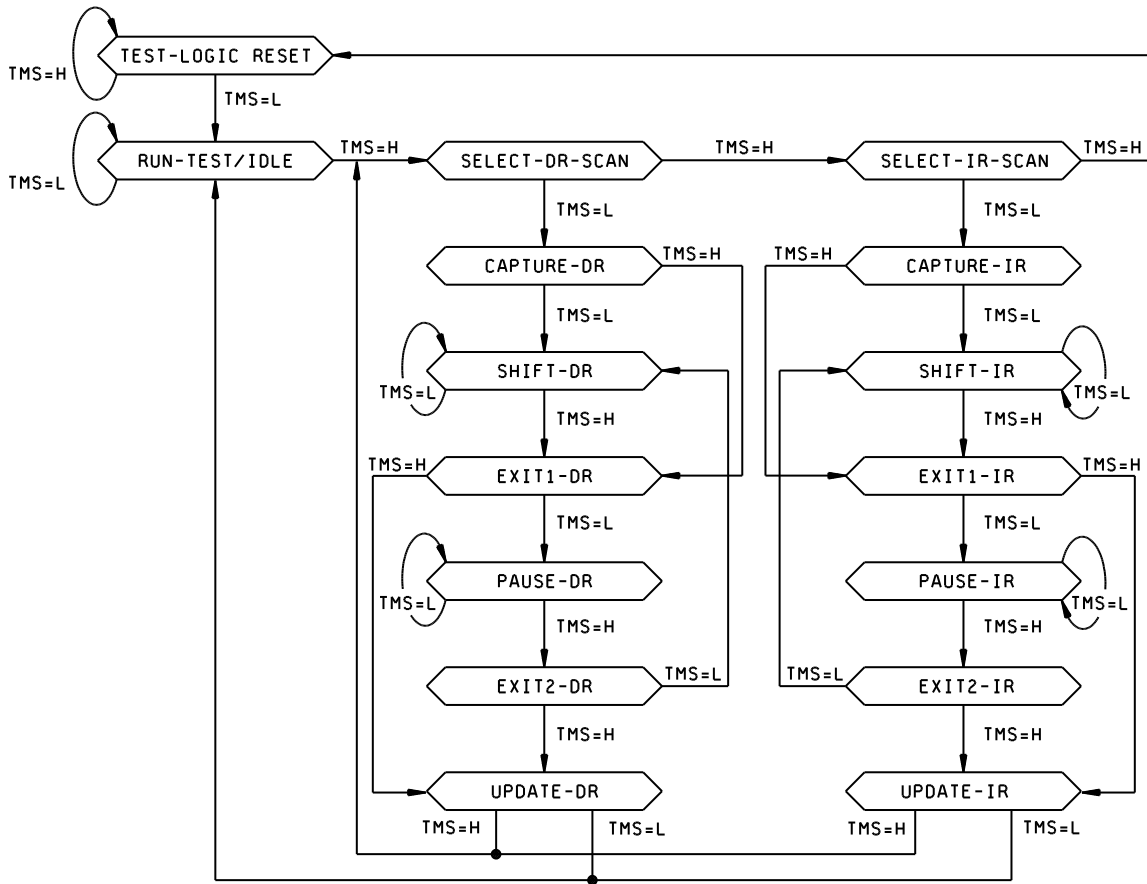

FIGURE 4. Test access port controller and scan test registers.

**STANDARD
MICROCIRCUIT DRAWING**
DLA LAND AND MARITIME
COLUMBUS, OHIO 43218-3990

SIZE
A

5962-94586

REVISION LEVEL
C

SHEET
15

Instruction register (IR) order of scan

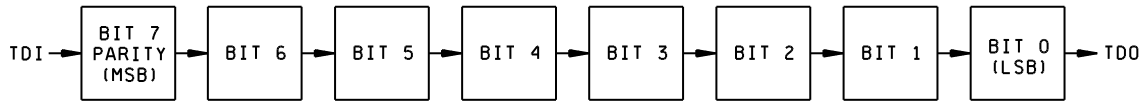

NOTE: During capture-IR, the IR captures the binary value 10000001. At power up or in the test-logic-reset state, the IR is reset to the binary value 11111111, which selects the BYPASS instruction.

Instruction register opcodes

Binary code ^{1/} Bit 7 → Bit 0 MSB → LSB	Scope™ opcode	Description	Selected data register	Mode
00000000	EXTEST	Boundary scan	Boundary-scan	Test
10000001	BYPASS ^{2/}	Bypass scan	Bypass	Normal
10000010	SAMPLE/PRELOAD	Sample boundary	Boundary scan	Normal
00000011	INTEST	Boundary scan	Boundary-scan	Test
10000100	BYPASS ^{2/}	Bypass scan	Bypass	Normal
00000101	BYPASS ^{2/}	Bypass scan	Bypass	Normal
00000110	HIGHZ	Control boundary to high impedance	Bypass	Modified test
10000111	CLAMP	Control boundary to 1/O	Bypass	Test
10001000	BYPASS ^{2/}	Bypass scan	Bypass	Normal
00001001	RUNT	Boundary run test	Bypass	Test
00001010	READBN	Boundary read	Boundary-scan	Normal
10001011	READBT	Boundary read	Boundary-scan	Test
00001100	CEKKTST	Boundary self test	Boundary-scan	Normal
10001101	TOPHIP	Boundary toggle outputs	Bypass	Test
10001110	SCANCN	Boundary-control register scan	Boundary-control	Normal
00001111	SCANCT	Boundary-control register scan	Boundary-control	Test
All others	BYPASS	Bypass scan	Bypass	Normal

^{1/} Bit 7 is used to maintain even parity in the 8-bit instruction.

^{2/} The BYPASS instruction is executed in lieu of a SCOPE™ instruction that is not supported in this device.

FIGURE 4. Test access port controller and scan test registers - Continued.

STANDARD MICROCIRCUIT DRAWING DLA LAND AND MARITIME COLUMBUS, OHIO 43218-3990	SIZE A		5962-94586
		REVISION LEVEL C	SHEET 16

Boundary-scan register (BSR) configuration

BSR bit number	Device signal	BSR bit number	Device signal	BSR bit number	Device signal	BSR bit number	Device signal	BSR bit number	Device signal
39	OEB	31	A8-I	23	A8-O	15	B8-I	7	B8-O
38	OEA	30	A7-I	22	A7-O	14	B7-I	6	B7-O
37	DIR	29	A6-I	21	A6-O	13	B6-I	5	B6-O
36	\overline{OE}	28	A5-I	20	A5-O	12	B5-I	4	B5-O
35	CLKAB	27	A4-I	19	A4-O	11	B4-I	3	B4-O
34	CLKBA	26	A3-I	18	A3-O	10	B3-I	2	B3-O
33	SAB	25	A2-I	17	A2-O	9	B2-I	1	B2-O
32	SBA	24	A1-I	16	A1-O	8	B1-I	0	B1-O

Boundary-control register (BCR) configuration

BCR bit number	Test control signal	BCR bit number	Test control signal	BCR bit number	Test control signal
10	MASK8	6	MASK4	2	OPCODE2
9	MASK7	5	MASK3	1	OPCODE1
8	MASK6	4	MASK2	0	OPCODE0
7	MASK5	3	MASK1	---	---

NOTE: During capture-DR (DR stands for data register), the contents of BCR are not changed. A power up or in the test-logic-reset state, the BCR is reset to the binary value of 0000000010 which selects the PSA test operation with no input masking.

Boundary-control register opcodes

Binary code Bit 2 → Bit 0 MSB → LSB	Description
X00	Sample inputs/toggle outputs (TOPSIP)
X01	Pseudo-random pattern generation/16-bit mode (PRPG)
X10	Parallel signature analysis/16-bit mode (PSA)
X11	Simultaneous PSA and PRPG/8-bit mode (PSA/PRPG)
111	Simultaneous PSA and binary count up/8-bit mode (PSA/COUNT)

Bypass register order of scan

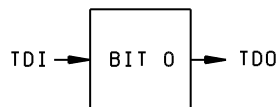

NOTE: During capture-DR, the bypass register captures a logic 0.

FIGURE 4. Test access port controller and scan test registers - Continued.

STANDARD MICROCIRCUIT DRAWING DLA LAND AND MARITIME COLUMBUS, OHIO 43218-3990	SIZE A		5962-94586
		REVISION LEVEL C	SHEET 17

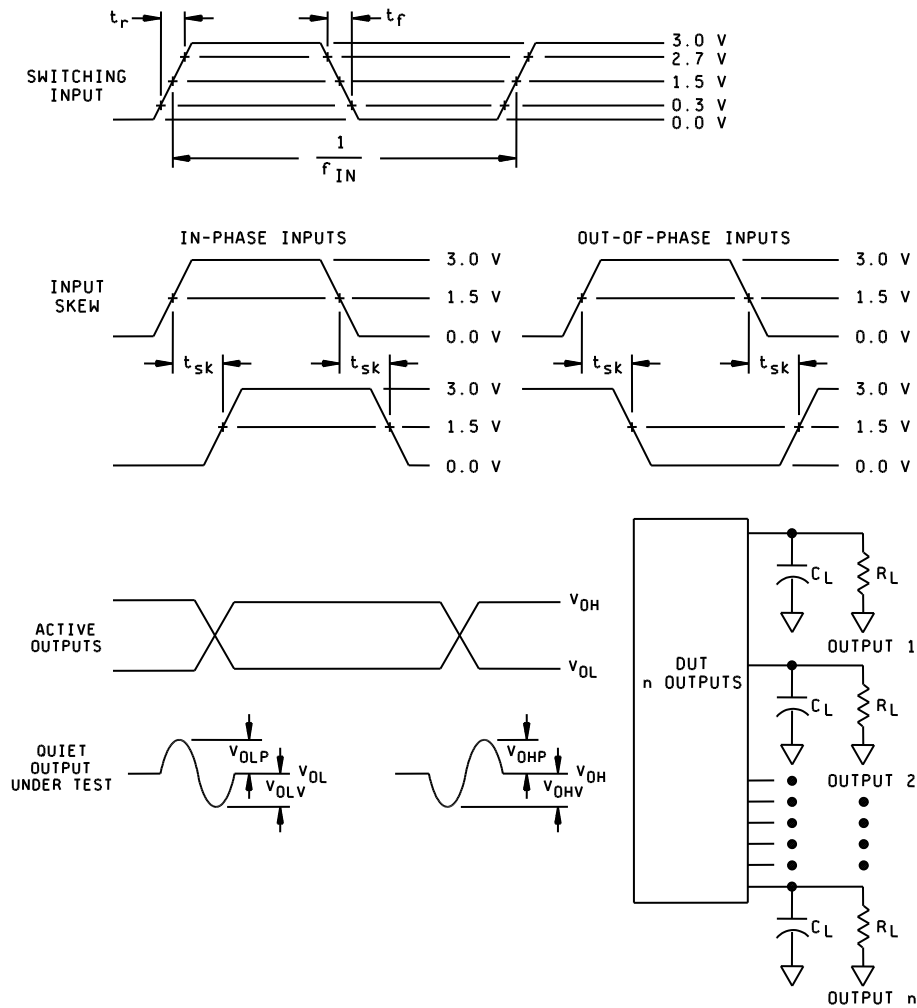

NOTES:

1. C_L includes a 47 pF chip capacitor (-0 percent, +20 percent) and at least 3 pF of equivalent capacitance from the test jig and probe.
2. $R_L = 450\Omega \pm 1$ percent, chip resistor in series with a 50 Ω termination. For monitored outputs, the 50 Ω termination shall be the 50 Ω characteristic impedance of the coaxial connector to the oscilloscope.
3. Input signal to the device under test:
 - a. $V_{IN} = 0.0$ V to 3.0 V; duty cycle = 50 percent; $f_{IN} \geq 1$ MHz.
 - b. $t_r, t_f = 3.0$ ns ± 1.0 ns. For input signal generators incapable of maintaining these values of t_r and t_f , the 3.0 ns limit may be increased up to 10 ns, as needed, maintaining the ± 1.0 ns tolerance and guaranteeing the results at 3.0 ns ± 1.0 ns; skew between any two switching input signals (t_{sk}): ≤ 250 ps.

FIGURE 5. Ground bounce waveforms and test circuit.

STANDARD MICROCIRCUIT DRAWING DLA LAND AND MARITIME COLUMBUS, OHIO 43218-3990	SIZE A		5962-94586
		REVISION LEVEL C	SHEET 18

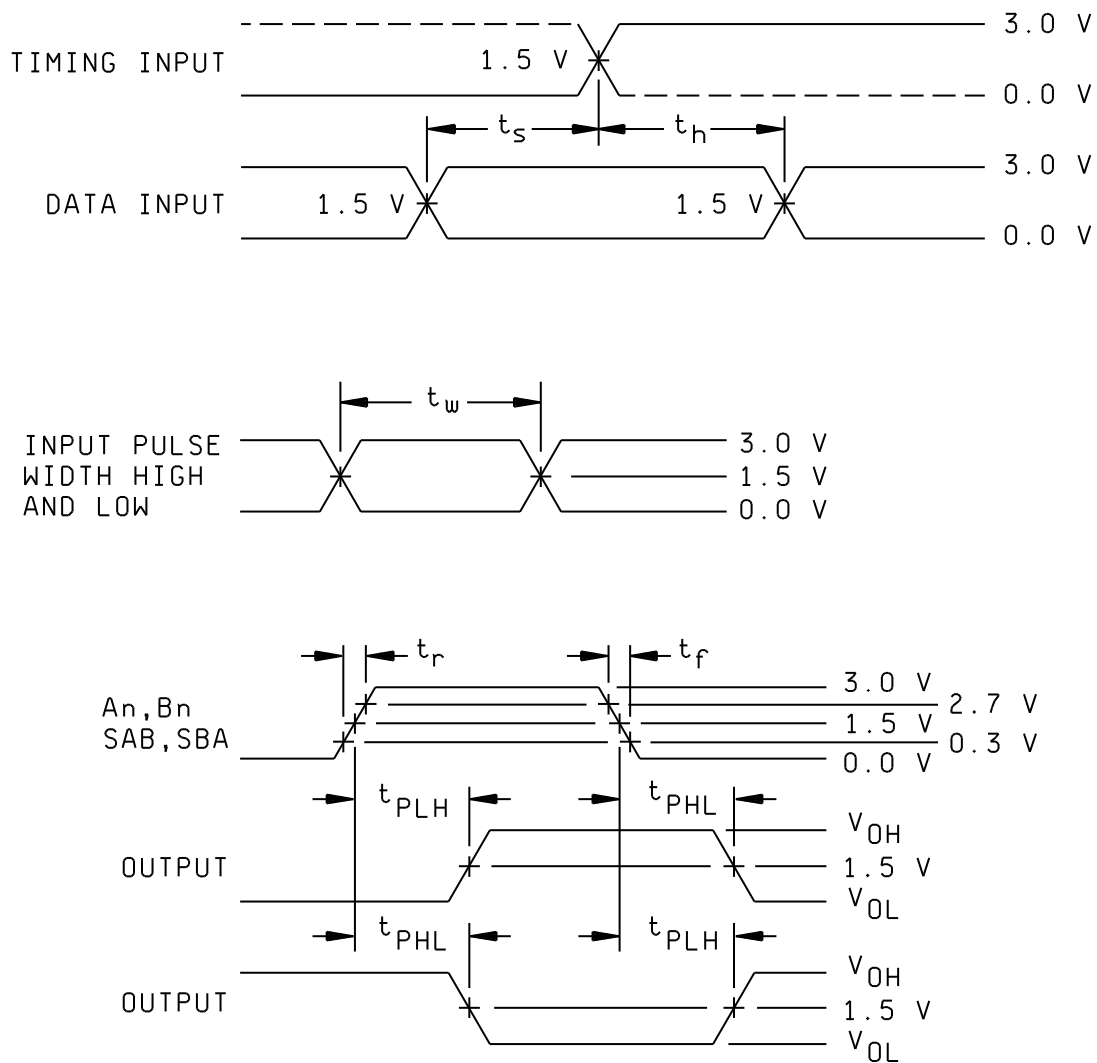

FIGURE 6. Switching waveforms and test circuit.

**STANDARD
MICROCIRCUIT DRAWING**
DLA LAND AND MARITIME
COLUMBUS, OHIO 43218-3990

SIZE
A

5962-94586

REVISION LEVEL
C

SHEET
19

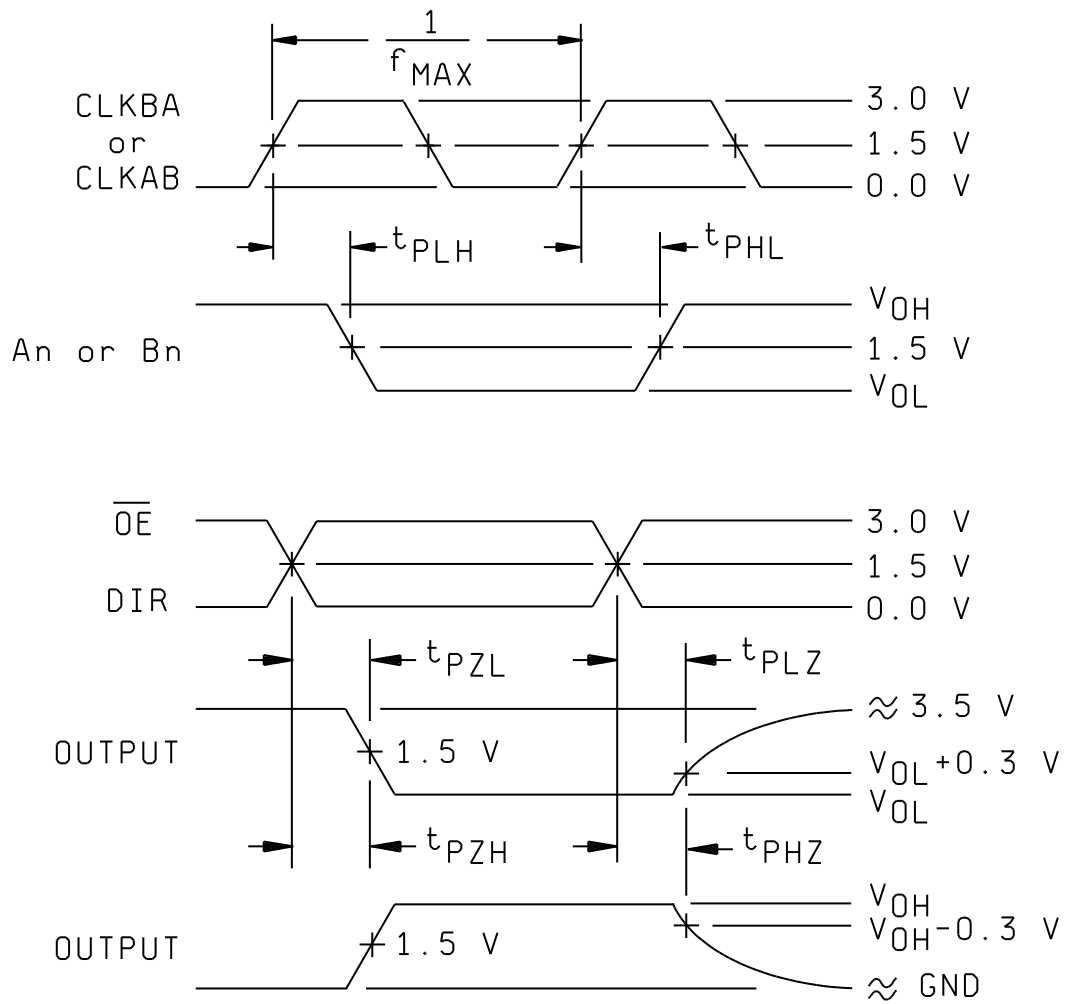

FIGURE 6. Switching waveforms and test circuit – Continued.

**STANDARD
MICROCIRCUIT DRAWING**
DLA LAND AND MARITIME
COLUMBUS, OHIO 43218-3990

SIZE
A

5962-94586

REVISION LEVEL
C

SHEET
20

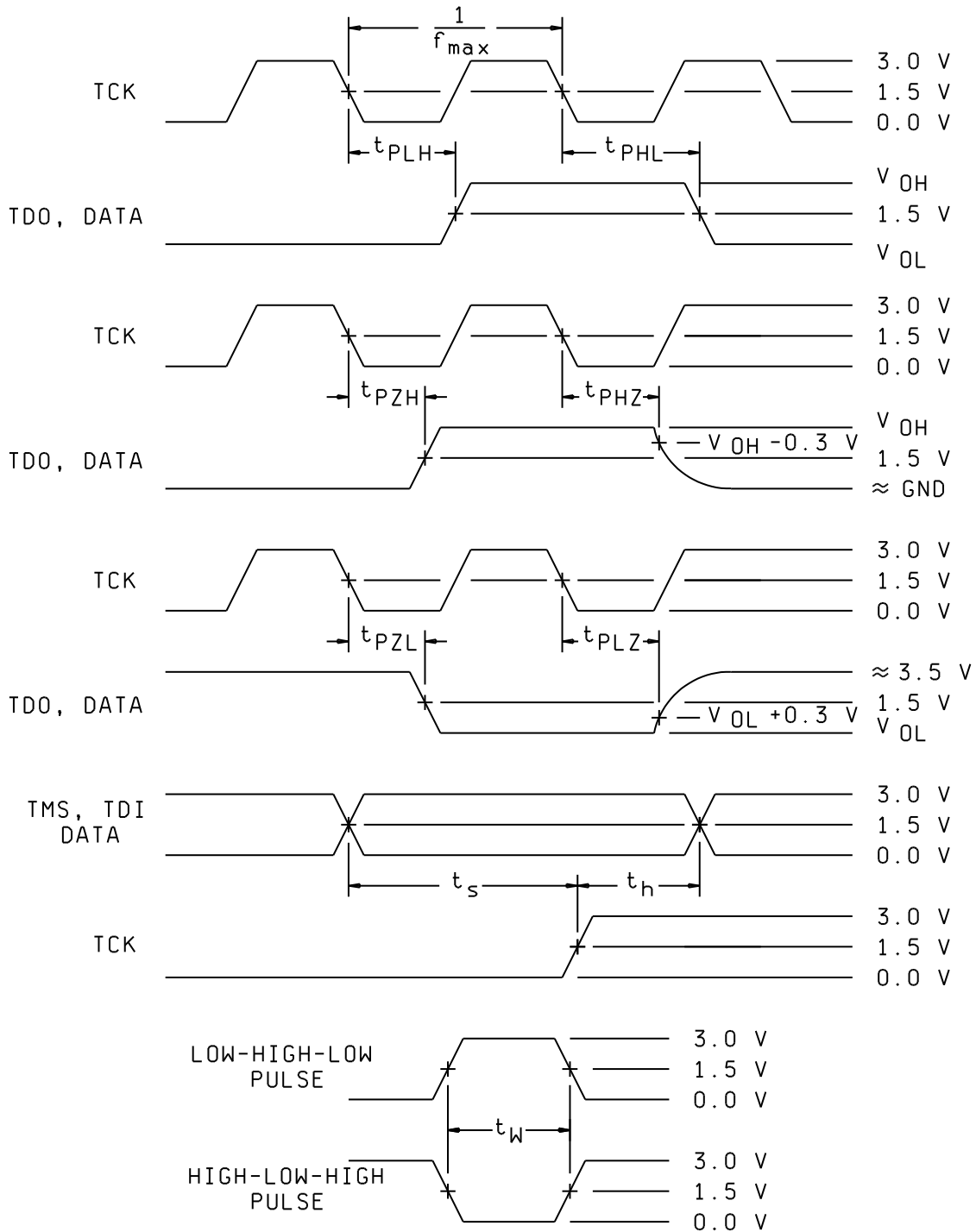

FIGURE 6. Switching waveforms and test circuit – Continued.

**STANDARD
MICROCIRCUIT DRAWING**
DLA LAND AND MARITIME
COLUMBUS, OHIO 43218-3990

SIZE
A

5962-94586

REVISION LEVEL
C

SHEET
21

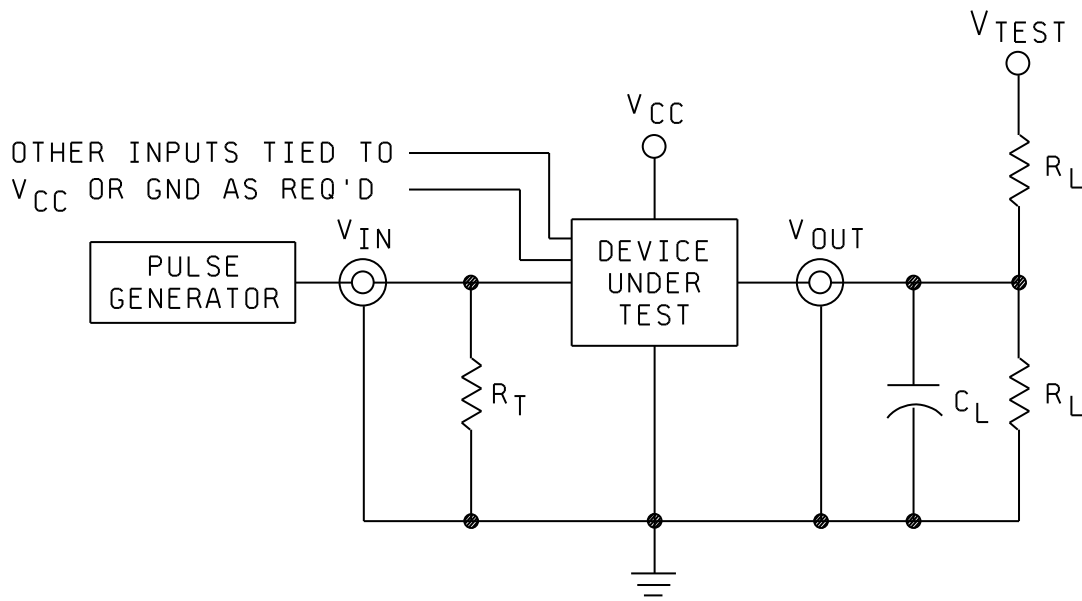

NOTES:

1. When measuring t_{PLZ} and t_{PZL} : $V_{TEST} = 7.0\text{ V}$.
2. When measuring t_{PHZ} , t_{PZH} , t_{PLH} and t_{PHL} : $V_{TEST} = \text{open}$.
3. The t_{PZL} and t_{PLZ} reference waveform is for the output under test with internal conditions such that the output is at V_{OL} except when disabled by the output enable control. The t_{PZH} and t_{PHZ} reference waveform is for the output under test with internal conditions such that the output is at V_{OH} except when disabled by the output enable control.
4. $C_L = 50\text{ pF}$ minimum or equivalent (includes test jig and probe capacitance).
5. $R_T = 50\Omega$ or equivalent. $R_L = 500\Omega$ or equivalent.
6. Input signal from pulse generator: $V_{IN} = 0.0\text{ V}$ to 3.0 V ; $PRR \leq 10\text{ MHz}$; $t_r \leq 2.5\text{ ns}$; $t_f \leq 2.5\text{ ns}$; t_r and t_f shall be measured from 0.3 V to 2.7 V and from 2.7 V to 0.3 V , respectively; duty cycle = 50 percent.
7. Timing parameters shall be tested at a minimum input frequency of 1 MHz.
8. The outputs are measured one at a time with one transition per measurement.

FIGURE 6. Switching waveforms and test circuit – Continued.

STANDARD MICROCIRCUIT DRAWING DLA LAND AND MARITIME COLUMBUS, OHIO 43218-3990	SIZE A		5962-94586
		REVISION LEVEL C	SHEET 22

4. VERIFICATION

4.1 Sampling and inspection. For device classes Q and V, sampling and inspection procedures shall be in accordance with MIL-PRF-38535 or as modified in the device manufacturer's Quality Management (QM) plan. The modification in the QM plan shall not affect the form, fit, or function as described herein. For device class M, sampling and inspection procedures shall be in accordance with MIL-PRF-38535, appendix A.

4.2 Screening. For device classes Q and V, screening shall be in accordance with MIL-PRF-38535, and shall be conducted on all devices prior to qualification and technology conformance inspection. For device class M, screening shall be in accordance with method 5004 of MIL-STD-883, and shall be conducted on all devices prior to quality conformance inspection.

4.2.1 Additional criteria for device class M.

a. Burn-in test, method 1015 of MIL-STD-883.

(1) Test condition A, B, C, or D. The test circuit shall be maintained by the manufacturer under document revision level control and shall be made available to the preparing or acquiring activity upon request. The test circuit shall specify the inputs, outputs, biases, and power dissipation, as applicable, in accordance with the intent specified in method 1015 of MIL-STD-883.

(2) $T_A = +125^{\circ}\text{C}$, minimum.

b. Interim and final electrical test parameters shall be as specified in table II herein.

4.2.2 Additional criteria for device classes Q and V.

a. The burn-in test duration, test condition and test temperature, or approved alternatives shall be as specified in the device manufacturer's QM plan in accordance with MIL-PRF-38535. The burn-in test circuit shall be maintained under document revision level control of the device manufacturer's Technology Review Board (TRB) in accordance with MIL-PRF-38535 and shall be made available to the acquiring or preparing activity upon request. The test circuit shall specify the inputs, outputs, biases, and power dissipation, as applicable, in accordance with the intent specified in method 1015 of MIL-STD-883.

b. Interim and final electrical test parameters shall be as specified in table II herein.

c. Additional screening for device class V beyond the requirements of device class Q shall be as specified in MIL-PRF-38535, appendix B.

4.3 Qualification inspection for device classes Q and V. Qualification inspection for device classes Q and V shall be in accordance with MIL-PRF-38535. Inspections to be performed shall be those specified in MIL-PRF-38535 and herein for groups A, B, C, D, and E inspections (see 4.4.1 through 4.4.4).

4.4 Conformance inspection. Technology conformance inspection for classes Q and V shall be in accordance with MIL-PRF-38535 including groups A, B, C, D, and E inspections and as specified herein. Quality conformance inspection for device class M shall be in accordance with MIL-PRF-38535, appendix A and as specified herein. Inspections to be performed for device class M shall be those specified in method 5005 of MIL-STD-883 and herein for groups A, B, C, D, and E inspections (see 4.4.1 through 4.4.4).

4.4.1 Group A inspection.

a. Tests shall be as specified in table II herein.

b. For device class M, subgroups 7 and 8 tests shall be sufficient to verify the truth table in figure 2 herein. The test vectors used to verify the truth table shall, at a minimum, test all functions of each input and output. All possible input to output logic patterns per function shall be guaranteed, if not tested, to the truth table in figure 2, herein. For device classes Q and V, subgroups 7 and 8 shall include verifying the functionality of the device.

STANDARD MICROCIRCUIT DRAWING DLA LAND AND MARITIME COLUMBUS, OHIO 43218-3990	SIZE A		5962-94586
		REVISION LEVEL C	SHEET 23

- c. C_{IN} , C_{OUT} , and $C_{I/O}$ shall be measured only for initial qualification and after process or design changes which may affect capacitance. C_{IN} , C_{OUT} , and $C_{I/O}$ shall be measured between the designated terminal and GND at a frequency of 1 MHz. This test may be performed at 10 MHz and guaranteed, if not tested, at 1 MHz. The DC bias for the pin under test (V_{BIAS}) = 2.5 V or 3.0 V. For C_{IN} , C_{OUT} , and $C_{I/O}$, test all applicable pins on five devices with zero failures.

For C_{IN} , C_{OUT} , and $C_{I/O}$ a device manufacturer may qualify devices by functional groups. A specific functional group shall be composed of function types, that by design, will yield the same capacitance values when tested in accordance with table I, herein. The device manufacturer shall set a function group limit for the C_{IN} , C_{OUT} , and $C_{I/O}$ tests. The device manufacturer may then test one device functional group, to the limits and conditions specified herein. All other device functions in that particular functional group shall be guaranteed, if not tested, to the limits and test conditions specified in table I, herein. The device manufacturers shall submit to DLA Land and Maritime-VA the device functions listed in each functional group and the test results for each device tested.

- d. Ground and V_{CC} bounce tests are required for all device classes. These tests shall be performed only for initial qualification, after process or design changes which may affect the performance of the device, and any changes to the test fixture. V_{OLP} , V_{OLV} , V_{OHP} , and V_{OHV} shall be measured for the worst case outputs of the device. All other outputs shall be guaranteed, if not tested, to the limits established for the worst case outputs. The worst case outputs tested are to be determined by the manufacturer. Test 5 devices assembled in the worst case package type supplied to this document. All other package types shall be guaranteed, if not tested, to the limits established for the worst case package. The package type to be tested shall be determined by the manufacturer. The device manufacturer will submit to DLA Land and Maritime-VA data that shall include all measured peak values for each device tested and detailed oscilloscope plots for each V_{OLP} , V_{OLV} , V_{OHP} , and V_{OHV} from one sample part per function. The plot shall contain the waveforms of both a switching output and the output under test.

Each device manufacturer shall test product on the fixtures they currently use. When a new fixture is used, the device manufacturer shall inform DLA Land and Maritime-VA of this change and test the 5 devices on both the new and old test fixtures. The device manufacturer shall then submit to DLA Land and Maritime-VA data from testing on both fixtures that shall include all measured peak values for each device tested and detailed oscilloscope plots for each V_{OLP} , V_{OLV} , V_{OHP} , and V_{OHV} from one sample part per function. The plot shall contain the waveforms of both a switching output and the output under test.

For V_{OHP} , V_{OHV} , V_{OLP} , and V_{OLV} , a device manufacturer may qualify devices by functional groups. A specific functional group shall be composed of function types, that by design, will yield the same test values when tested in accordance with table I, herein. The device manufacturer shall set a functional group limit for the V_{OHP} , V_{OHV} , V_{OLP} , and V_{OLV} tests. The device manufacturer may then test one device function from a functional group to the limits and conditions specified herein. All other device functions in that particular functional group shall be guaranteed, if not tested, to the limits and conditions specified in table I, herein. The device manufacturer shall submit to DLA Land and Maritime-VA the device functions listed in each functional group and the test results, along with the oscilloscope plots, for each device tested.

4.4.2 Group C inspection. The group C inspection end-point electrical parameters shall be as specified in table II herein.

4.4.2.1 Additional criteria for device class M. Steady-state life test conditions, method 1005 of MIL-STD-883:

- a. Test condition A, B, C, or D. The test circuit shall be maintained by the manufacturer under document revision level control and shall be made available to the preparing or acquiring activity upon request. The test circuit shall specify the inputs, outputs, biases, and power dissipation, as applicable, in accordance with the intent specified in method 1005 of MIL-STD-883.
- b. $T_A = +125^\circ\text{C}$, minimum.
- c. Test duration: 1,000 hours, except as permitted by method 1005 of MIL-STD-883.

4.4.2.2 Additional criteria for device classes Q and V. The steady-state life test duration, test condition and test temperature, or approved alternatives shall be as specified in the device manufacturer's QM plan in accordance with MIL-PRF-38535. The test circuit shall be maintained under document revision level control by the device manufacturer's TRB in accordance with MIL-PRF-38535 and shall be made available to the acquiring or preparing activity upon request. The test circuit shall specify the inputs, outputs, biases, and power dissipation, as applicable, in accordance with the intent specified in method 1005 of MIL-STD-883.

4.4.3 Group D inspection. The group D inspection end-point electrical parameters shall be as specified in table II herein.

STANDARD MICROCIRCUIT DRAWING DLA LAND AND MARITIME COLUMBUS, OHIO 43218-3990	SIZE A		5962-94586
		REVISION LEVEL C	SHEET 24

4.4.4 Group E inspection. Group E inspection is required only for parts intended to be marked as radiation hardness assured (see 3.5 herein).

- a. End-point electrical parameters shall be as specified in table II herein.
- b. For device classes Q and V, the devices or test vehicle shall be subjected to radiation hardness assured tests as specified in MIL-PRF-38535 for the RHA level being tested. For device class M, the devices shall be subjected to radiation hardness assured tests as specified in MIL-PRF-38535, appendix A for the RHA level being tested. All device classes must meet the postirradiation end-point electrical parameter limits as defined in table I at $T_A = +25^{\circ}\text{C} \pm 5^{\circ}\text{C}$, after exposure, to the subgroups specified in table II herein.

TABLE II. Electrical test requirements.

Test requirements	Subgroups (in accordance with MIL-STD-883, method 5005, table I)	Subgroups (in accordance with MIL-PRF-38535, table III)	
	Device class M	Device class Q	Device class V
Interim electrical parameters (see 4.2)	---	---	1
Final electrical parameters (see 4.2)	<u>1/</u> 1, 2, 3, 7, 8, 9, 10, 11	<u>1/</u> 1, 2, 3, 7, 8, 9, 10, 11	<u>2/</u> 1, 2, 3, 7, 8, 9, 10, 11
Group A test requirements (see 4.4)	1, 2, 3, 4, 7, 8, 9, 10, 11	1, 2, 3, 4, 7, 8, 9, 10, 11	1, 2, 3, 4, 7, 8, 9, 10, 11
Group C end-point electrical parameters (see 4.4)	1, 2, 3	1, 2, 3	1, 2, 3, 7, 8
Group D end-point electrical parameters (see 4.4)	1, 2, 3	1, 2, 3	1, 2, 3, 7, 8
Group E end-point electrical parameters (see 4.4)	1, 7, 9	1, 7, 9	1, 7, 9

- 1/ PDA applies to subgroup 1.
- 2/ PDA applies to subgroups 1 and 7.

4.5 Methods of inspection. Methods of inspection shall be specified as follows:

4.5.1 Voltage and current. Unless otherwise specified, all voltages given are referenced to the microcircuit GND terminal. Currents given are conventional current and positive when flowing into the referenced terminal.

5. PACKAGING

5.1 Packaging requirements. The requirements for packaging shall be in accordance with MIL-PRF-38535 for device classes Q and V or MIL-PRF-38535, appendix A for device class M.

STANDARD MICROCIRCUIT DRAWING DLA LAND AND MARITIME COLUMBUS, OHIO 43218-3990	SIZE A		5962-94586
		REVISION LEVEL C	SHEET 25

6. NOTES

6.1 Intended use. Microcircuits conforming to this drawing are intended for use for Government microcircuit applications (original equipment), design applications, and logistics purposes.

6.1.1 Replaceability. Microcircuits covered by this drawing will replace the same generic device covered by a contractor-prepared specification or drawing.

6.1.2 Substitutability. Device class Q devices will replace device class M devices.

6.2 Configuration control of SMD's. All proposed changes to existing SMD's will be coordinated with the users of record for the individual documents. This coordination will be accomplished using DD Form 1692, Engineering Change Proposal.

6.3 Record of users. Military and industrial users should inform DLA Land and Maritime when a system application requires configuration control and which SMD's are applicable to that system. DLA Land and Maritime will maintain a record of users and this list will be used for coordination and distribution of changes to the drawings. Users of drawings covering microelectronic devices (FSC 5962) should contact DLA Land and Maritime-VA, telephone (614) 692-8101.

6.4 Comments. Comments on this drawing should be directed to DLA Land and Maritime-VA, Columbus, Ohio 43218-3990, or telephone (614) 692-0540.

6.5 Abbreviations, symbols, and definitions. The abbreviations, symbols, and definitions used herein are defined in MIL-PRF-38535 and MIL-HDBK-1331.

6.6 Sources of supply.

6.6.1 Sources of supply for device classes Q and V. Sources of supply for device classes Q and V are listed in MIL-HDBK-103 and QML-38535. The vendors listed in MIL-HDBK-103 and QML-38535 have submitted a certificate of compliance (see 3.6 herein) to DLA Land and Maritime-VA and have agreed to this drawing.

6.6.2 Approved sources of supply for device class M. Approved sources of supply for class M are listed in MIL-HDBK-103. The vendors listed in MIL-HDBK-103 have agreed to this drawing and a certificate of compliance (see 3.6 herein) has been submitted to and accepted by DLA Land and Maritime-VA.

STANDARD MICROCIRCUIT DRAWING DLA LAND AND MARITIME COLUMBUS, OHIO 43218-3990	SIZE A		5962-94586
		REVISION LEVEL C	SHEET 26

STANDARD MICROCIRCUIT DRAWING BULLETIN

DATE: 21-01-25

Approved sources of supply for SMD 5962-94586 are listed below for immediate acquisition information only and shall be added to MIL-HDBK-103 and QML-38535 during the next revision. MIL-HDBK-103 and QML-38535 will be revised to include the addition or deletion of sources. The vendors listed below have agreed to this drawing and a certificate of compliance has been submitted to and accepted by DLA Land and Maritime-VA. This information bulletin is superseded by the next dated revision of MIL-HDBK-103 and QML-38535. DLA Land and Maritime maintains an online database of all current sources of supply at <https://landandmaritimeapps.dla.mil/programs/smcr/>.

Standard microcircuit drawing PIN 1/	Vendor CAGE number	Vendor similar PIN 2/
5962-9458601QXA	01295	SNJ54ABT8646JT
5962-9458601Q3A	01295	SNJ54ABT8646FK

- 1/ The lead finish shown for each PIN representing a hermetic package is the most readily available from the manufacturer listed for that part. If the desired lead finish is not listed, contact the vendor to determine its availability.
- 2/ Caution. Do not use this number for item acquisition. Items acquired to this number may not satisfy the performance requirements of this drawing.

Vendor CAGE
number

01295

Vendor name
and address

Texas Instruments, Inc.
Semiconductor Group
8505 Forest Ln.
P.O. Box 660199
Dallas, TX 75243

The information contained herein is disseminated for convenience only and the Government assumes no liability whatsoever for any inaccuracies in the information bulletin.