

REVISIONS

LTR	DESCRIPTION	DATE (YR-MO-DA)	APPROVED
A	Make change to "VREFH to VREFL" limits as specified in 1.3 and add functional test to table I. - ro	01-06-05	R. Monnin
B	Redraw. Update drawing to current requirements. - drw	12-03-22	Charles F. Saffle
C	Update paragraphs to MIL-PRF-38535 requirements. - drw	18-07-10	Charles F. Saffle



REV																				
SHEET																				
REV																				
SHEET																				
REV STATUS	REV	C	C	C	C	C	C	C	C	C	C	C	C	C	C	C	C	C	C	C
OF SHEETS	SHEET	1	2	3	4	5	6	7	8	9	10	11	12	13	14					

PMIC N/A	PREPARED BY Sandra B. Rooney	<p align="center">DLA LAND AND MARITIME COLUMBUS, OHIO 43218-3990 http://www.dla.mil/landandmaritime</p>																	
<p align="center">STANDARD MICROCIRCUIT DRAWING</p> <p>THIS DRAWING IS AVAILABLE FOR USE BY ALL DEPARTMENTS AND AGENCIES OF THE DEPARTMENT OF DEFENSE</p> <p align="center">AMSC N/A</p>	CHECKED BY Charles E. Besore																		
	APPROVED BY Michael A. Frye	<p align="center">MICROCIRCUIT, DIGITAL-LINEAR, 12-BIT, QUAD, D/A CONVERTER, MONOLITHIC SILICON</p>																	
	DRAWING APPROVAL DATE 93-05-20																		
	REVISION LEVEL C		SIZE A	CAGE CODE 67268	5962-91764														
		SHEET 1 OF 14																	

1. SCOPE

1.1 Scope. This drawing documents two product assurance class levels consisting of high reliability (device class Q and M) and space application (device class V). A choice of case outlines and lead finishes are available and are reflected in the Part or Identifying Number (PIN). When available, a choice of Radiation Hardness Assurance (RHA) levels is reflected in the PIN.

1.2 PIN. The PIN is as shown in the following example:

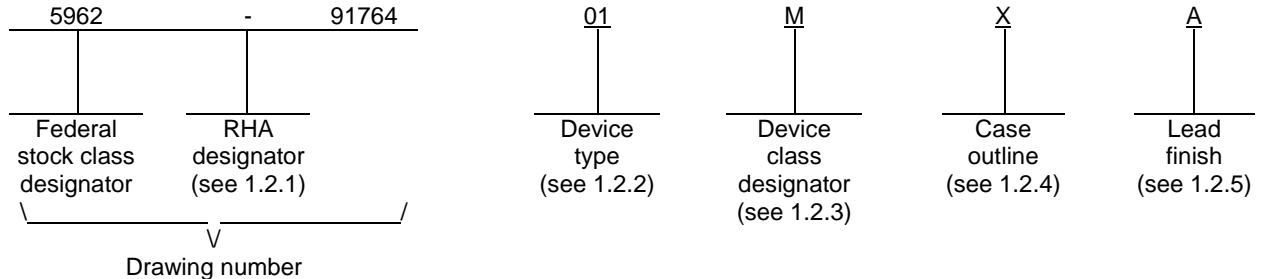

1.2.1 RHA designator. Device classes Q and V RHA marked devices meet the MIL-PRF-38535 specified RHA levels and are marked with the appropriate RHA designator. Device class M RHA marked devices meet the MIL-PRF-38535, appendix A specified RHA levels and are marked with the appropriate RHA designator. A dash (-) indicates a non-RHA device.

1.2.2 Device types. The device types identify the circuit function as follows:

<u>Device type</u>	<u>Generic number</u>	<u>Circuit function</u>	<u>Output registers on reset (see figure 2)</u>
01	DAC8412A	Quad, voltage output, 12-bit BiCMOS DAC with readback	Midscale
02	DAC8412B	Quad, voltage output, 12-bit BiCMOS DAC with readback	Midscale
03	DAC8413A	Quad, voltage output, 12-bit BiCMOS DAC with readback	Zero scale
04	DAC8413B	Quad, voltage output, 12-bit BiCMOS DAC with readback	Zero scale

1.2.3 Device class designator. The device class designator is a single letter identifying the product assurance level as follows:

<u>Device class</u>	<u>Device requirements documentation</u>
M	Vendor self-certification to the requirements for MIL-STD-883 compliant, non-JAN class level B microcircuits in accordance with MIL-PRF-38535, appendix A
Q or V	Certification and qualification to MIL-PRF-38535

1.2.4 Case outlines. The case outlines are as designated in MIL-STD-1835 as follows:

<u>Outline letter</u>	<u>Descriptive designator</u>	<u>Terminals</u>	<u>Package style</u>
X	GDIP1-T28 or CDIP2-T28	28	Dual-in-line
3	CQCC1-N28	28	Square leadless chip carrier

1.2.5 Lead finish. The lead finish is as specified in MIL-PRF-38535 for device classes Q and V or MIL-PRF-38535, appendix A for device class M.

STANDARD MICROCIRCUIT DRAWING DLA LAND AND MARITIME COLUMBUS, OHIO 43218-3990	SIZE A		5962-91764
		REVISION LEVEL C	SHEET 2

1.3 Absolute maximum ratings. 1/

VSS to VDD	-0.3 V dc, +33.0 V dc
VSS to VLOGIC	-0.3 V dc, +23.5 V dc
VSS to DGND	-16.5 V dc
VDD to DGND	+16.5 V dc
VLOGIC to DGND	-0.3 V dc, +7.0 V dc
VSS to VREFL	-0.3 V dc, VDD - 2.0 V dc
VREFH to VDD	+2.0 V dc, +33.0 V dc
VREFH to VREFL	0 V dc, VDD - VSS
Current into any pin	±15 mA
Digital input voltage to DGND	-0.3 V dc, VLOGIC + 0.3 V dc
Digital output voltage to DGND	-0.3 V dc, +7.0 V dc
Power dissipation (PD)	1000 mW 2/
Junction temperature (TJ)	+150°C
Storage temperature range	-65°C to +150°C
Lead temperature (soldering, 60 seconds)	+300°C
Thermal resistance, junction-to-case (θJC)	See MIL-STD-1835
Thermal resistance, junction-to-ambient (θJA):	
Case X	50°C/W
Case 3	70°C/W

1.4 Recommended operating conditions.

Supply voltage range	±15 V dc
Logic supply voltage (VLOGIC)	+5 V dc
Positive reference voltage range (+VREF)	+2.5 V dc to +10.0 V dc
Negative reference voltage range (-VREF)	-10.0 V dc to 0 V dc
Ground potential	0 V dc
Ambient operating temperature range (TA)	-55°C to +125°C

2. APPLICABLE DOCUMENTS

2.1 Government specification, standards, and handbooks. The following specification, standards, and handbooks form a part of this drawing to the extent specified herein. Unless otherwise specified, the issues of these documents are those cited in the solicitation or contract.

DEPARTMENT OF DEFENSE SPECIFICATION

MIL-PRF-38535 - Integrated Circuits, Manufacturing, General Specification for.

DEPARTMENT OF DEFENSE STANDARDS

MIL-STD-883 - Test Method Standard Microcircuits.
MIL-STD-1835 - Interface Standard Electronic Component Case Outlines.

1/ Stresses above the absolute maximum rating may cause permanent damage to the device. Extended operation at the maximum levels may degrade performance and affect reliability.

2/ Derate above +80°C at 14.3 mW/°C for case 3. Derate above +100°C at 20 mW/°C for case X.

STANDARD MICROCIRCUIT DRAWING DLA LAND AND MARITIME COLUMBUS, OHIO 43218-3990	SIZE A		5962-91764
		REVISION LEVEL C	SHEET 3

DEPARTMENT OF DEFENSE HANDBOOKS

- MIL-HDBK-103 - List of Standard Microcircuit Drawings.
- MIL-HDBK-780 - Standard Microcircuit Drawings.

(Copies of these documents are available online at <http://quicksearch.dla.mil>).

2.2 Order of precedence. In the event of a conflict between the text of this drawing and the references cited herein, the text of this drawing takes precedence. Nothing in this document, however, supersedes applicable laws and regulations unless a specific exemption has been obtained.

3. REQUIREMENTS

3.1 Item requirements. The individual item requirements for device classes Q and V shall be in accordance with MIL-PRF-38535 as specified herein, or as modified in the device manufacturer's Quality Management (QM) plan. The modification in the QM plan shall not affect the form, fit, or function as described herein. The individual item requirements for device class M shall be in accordance with MIL-PRF-38535, appendix A for non-JAN class level B devices and as specified herein.

3.2 Design, construction, and physical dimensions. The design, construction, and physical dimensions shall be as specified in MIL-PRF-38535 and herein for device classes Q and V or MIL-PRF-38535, appendix A and herein for device class M.

3.2.1 Case outlines. The case outlines shall be in accordance with 1.2.4 herein.

3.2.2 Terminal connections. The terminal connections shall be as specified on figure 1.

3.2.3 Truth table. The truth table shall be as specified on figure 2.

3.2.4 Block diagram. The block diagram shall be as specified on figure 3.

3.3 Electrical performance characteristics and postirradiation parameter limits. Unless otherwise specified herein, the electrical performance characteristics and postirradiation parameter limits are as specified in table I and shall apply over the full ambient operating temperature range.

3.4 Electrical test requirements. The electrical test requirements shall be the subgroups specified in table II. The electrical tests for each subgroup are defined in table I.

3.5 Marking. The part shall be marked with the PIN listed in 1.2 herein. In addition, the manufacturer's PIN may also be marked. For packages where marking of the entire SMD PIN number is not feasible due to space limitations, the manufacturer has the option of not marking the "5962-" on the device. For RHA product using this option, the RHA designator shall still be marked. Marking for device classes Q and V shall be in accordance with MIL-PRF-38535. Marking for device class M shall be in accordance with MIL-PRF-38535, appendix A.

3.5.1 Certification/compliance mark. The certification mark for device classes Q and V shall be a "QML" or "Q" as required in MIL-PRF-38535. The compliance mark for device class M shall be a "C" as required in MIL-PRF-38535, appendix A.

3.6 Certificate of compliance. For device classes Q and V, a certificate of compliance shall be required from a QML-38535 listed manufacturer in order to supply to the requirements of this drawing (see 6.6.1 herein). For device class M, a certificate of compliance shall be required from a manufacturer in order to be listed as an approved source of supply in MIL-HDBK-103 (see 6.6.2 herein). The certificate of compliance submitted to DLA Land and Maritime-VA prior to listing as an approved source of supply for this drawing shall affirm that the manufacturer's product meets, for device classes Q and V, the requirements of MIL-PRF-38535 and herein or for device class M, the requirements of MIL-PRF-38535, appendix A and herein.

3.7 Certificate of conformance. A certificate of conformance as required for device classes Q and V in MIL-PRF-38535 or for device class M in MIL-PRF-38535, appendix A shall be provided with each lot of microcircuits delivered to this drawing.

STANDARD MICROCIRCUIT DRAWING DLA LAND AND MARITIME COLUMBUS, OHIO 43218-3990	SIZE A		5962-91764
		REVISION LEVEL C	SHEET 4

TABLE I. Electrical performance characteristics.

Test	Symbol	Conditions ^{1/} -55°C ≤ TA ≤ +125°C unless otherwise specified	Group A subgroups	Device type	Limits		Unit
					Min	Max	
Integral linearity	INL		1, 2, 3	01, 03	-0.75	+0.75	LSB
				02, 04	-1.5	+1.5	
Differential linearity	DNL		1, 2, 3	All	-1.0	+1.0	LSB
Minimum scale error	VZSE	RL ≥ 2 kΩ	1, 2, 3	All	-2.0	+2.0	LSB
Full scale error	VFSE	RL ≥ 2 kΩ	1, 2, 3	All	-2.0	+2.0	LSB
Linearity matching		TA = +25°C	1	All	-1.0	+1.0	LSB
Minimum scale offset matching		TA = +25°C	1	All	-1.0	+1.0	LSB
Full scale offset matching		TA = +25°C	1	All	-2.0	+2.0	LSB
Reference input current	IREFH	Code 555H & 000H	1, 2, 3	All	-2.75	+2.75	mA
	IREFL				0	+2.75	
Output voltage swing	VOUT (MIN)	RL = 2 kΩ	1, 2, 3	All	-10.0098	-9.9902	V
	VOUT (MAX)				+9.9853	+10.0048	
Logic input high voltage	VINH		1, 2, 3	All	2.4		V
Logic input low voltage	VINL		1, 2, 3	All		0.8	V
Logic output high voltage	VOH	IOH = +0.4 mA	1, 2, 3	All	2.4		V
Logic output low voltage	VOL	IOL = -1.6 mA	1, 2, 3	All		0.4	V
Logic input current	IIN	VIN = 0 V or + 5 V	1, 2, 3	All		10	μA
Power supply sensitivity	PSS	14.25 V ≤ VDD ≤ 15.75 V	1, 2, 3	All		150	ppm/V

See footnotes at end of table.

STANDARD MICROCIRCUIT DRAWING DLA LAND AND MARITIME COLUMBUS, OHIO 43218-3990	SIZE A		5962-91764
		REVISION LEVEL C	SHEET 5

TABLE I. Electrical performance characteristics – continued.

Test	Symbol	Conditions <u>1/</u> -55°C ≤ TA ≤ +125°C unless otherwise specified	Group A subgroups	Device type	Limits		Unit
					Min	Max	
Positive supply current	IDD	VREFH = +2.5 V	1, 2, 3	All		13	mA
Negative supply current	ISS		1, 2, 3	All	-10		mA
Logic supply current	ILOGIC		1, 2, 3	All		100	μA
Slew rate	SR	Measured at 10 % to 90 %, TA = +25°C, VO = 0 V to 10 V <u>2/</u>	4	All	2		V/μs
Functional test	FT	See 4.4.1c	7	All			
Settling time	tS	10 V step to 0.01 %, <u>2/</u> TA = +25°C	9	All		15	μs
Chip select write pulse width	tWCS	<u>2/</u> , <u>3/</u>	9, 10, 11	All	90		ns
Write setup	tWS	tWCS = 90 ns <u>2/</u> , <u>3/</u>	9, 10, 11	All	0		ns
Write hold	tWH	tWCS = 90 ns <u>2/</u> , <u>3/</u>	9, 10, 11	All	0		ns
Address setup	tAS	<u>2/</u> , <u>3/</u>	9, 10, 11	All	0		ns
Address hold	tAH	<u>2/</u> , <u>3/</u>	9, 10, 11	All	0		ns
Load setup	tLS	<u>2/</u> , <u>3/</u>	9, 10, 11	All	70		ns
WRITE load hold	tLH	<u>2/</u> , <u>3/</u>	9, 10, 11	All	30		ns
WRITE data setup	tWDS	tWCS = 90 ns <u>2/</u> , <u>3/</u>	9, 10, 11	All	20		ns
WRITE data hold	tWDH	tWCS = 90 ns <u>2/</u> , <u>3/</u>	9, 10, 11	All	0		ns
Load pulse width	tLWD	<u>2/</u> , <u>3/</u>	9, 10, 11	All	170		ns
Reset pulse width	tRESET	<u>2/</u> , <u>3/</u>	9, 10, 11	All	200		ns
Chip select read pulse width	tRCS	<u>2/</u> , <u>3/</u>	9, 10, 11	All	130		ns

See footnotes at end of table.

STANDARD MICROCIRCUIT DRAWING DLA LAND AND MARITIME COLUMBUS, OHIO 43218-3990	SIZE A		5962-91764
		REVISION LEVEL C	SHEET 6

TABLE I. Electrical performance characteristics – continued.

Test	Symbol	Conditions <u>1/</u> -55°C ≤ TA ≤ +125°C unless otherwise specified	Group A subgroups	Device type	Limits		Unit
					Min	Max	
Read data hold	tRDH	tRCS = 130 ns <u>2/ 3/</u>	9, 10, 11	All	0		ns
Read data setup	tRDS	tRCS = 130 ns <u>2/ 3/</u>	9, 10, 11	All	10		ns
Data to high Z	tDZ	RL = 3 kΩ, CL = 10 pF <u>2/ 3/</u>	9, 10, 11	All		200	ns
Chip select to data	tCSD	RL = 3 kΩ, CL = 100 pF <u>2/ 3/</u>	9, 10, 11	All		200	ns

1/ All supplies can be varied ±5 % and operation is guaranteed. Unless otherwise specified, VDD = +15 V, VSS = -15 V, VLOGIC = +5 V, VREFH = +10 V, and VREFL = -10 V.

2/ Guaranteed by characterization and not 100 % tested.

3/ All input control signals are specified with tr = tf = 5 ns (10 % to 90 % of +5 V) and timed from a voltage level of 1.6 V. See figure 4.

STANDARD MICROCIRCUIT DRAWING DLA LAND AND MARITIME COLUMBUS, OHIO 43218-3990	SIZE A		5962-91764
		REVISION LEVEL C	SHEET 7

Device types	01, 02, 03, 04
Case outlines	X and 3
Terminal number	Terminal symbol
1	VREFH
2	VOUTB
3	VOUTA
4	VSS
5	DGND
6	$\overline{\text{RESET}}$
7	$\overline{\text{LDAC}}$
8	DB0 (LSB)
9	DB1
10	DB2
11	DB3
12	DB4
13	DB5
14	DB6
15	DB7
16	DB8
17	DB9
18	DB10
19	DB11 (MSB)
20	R / $\overline{\text{W}}$
21	A1
22	A0
23	$\overline{\text{CS}}$
24	VLOGIC
25	VDD
26	VOUTD
27	VOUTC
28	VREFL

FIGURE 1. Terminal connections.

STANDARD MICROCIRCUIT DRAWING DLA LAND AND MARITIME COLUMBUS, OHIO 43218-3990	SIZE A		5962-91764
		REVISION LEVEL C	SHEET 8

A1	A0	R / \overline{W}	\overline{CS}	\overline{RS}	\overline{LDAC}	Input reg	Output reg	Mode	DAC
L	L	L	L	H	L	Write	Write	Write	A
L	H	L	L	H	L	Write	Write	Write	B
H	L	L	L	H	L	Write	Write	Write	C
H	H	L	L	H	L	Write	Write	Write	D
L	L	L	L	H	H	Write	Hold	Write input	A
L	H	L	L	H	H	Write	Hold	Write input	B
H	L	L	L	H	H	Write	Hold	Write input	C
H	H	L	L	H	H	Write	Hold	Write input	D
L	L	H	L	H	H	Read	Hold	Read input	A
L	H	H	L	H	H	Read	Hold	Read input	B
H	L	H	L	H	H	Read	Hold	Read input	C
H	H	H	L	H	H	Read	Hold	Read input	D
X	X	X	H	H	L	Hold	Update all output registers		ALL
X	X	X	H	H	H	Hold	Hold	Hold	ALL
X	X	X	X	L	X	* All registers reset to mid/zero scale			ALL
X	X	X	H	↑	X	* All registers latched to mid/zero scale			ALL

* Device types 01 and 02 reset to midscale, and device types 03 and 04 reset to zero scale.

L = Low
H = High
X = Don't care

FIGURE 2. Truth table.

STANDARD MICROCIRCUIT DRAWING DLA LAND AND MARITIME COLUMBUS, OHIO 43218-3990	SIZE A		5962-91764
		REVISION LEVEL C	SHEET 9

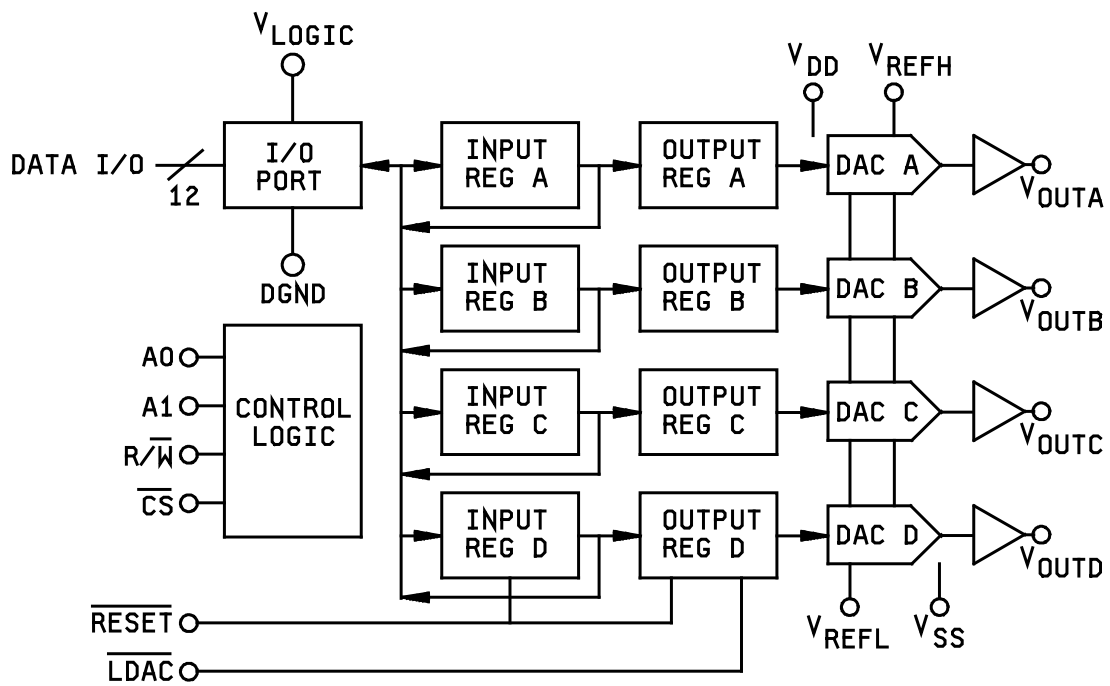

FIGURE 3. Block diagram.

**STANDARD
MICROCIRCUIT DRAWING**
DLA LAND AND MARITIME
COLUMBUS, OHIO 43218-3990

SIZE
A

5962-91764

REVISION LEVEL
C

SHEET
10

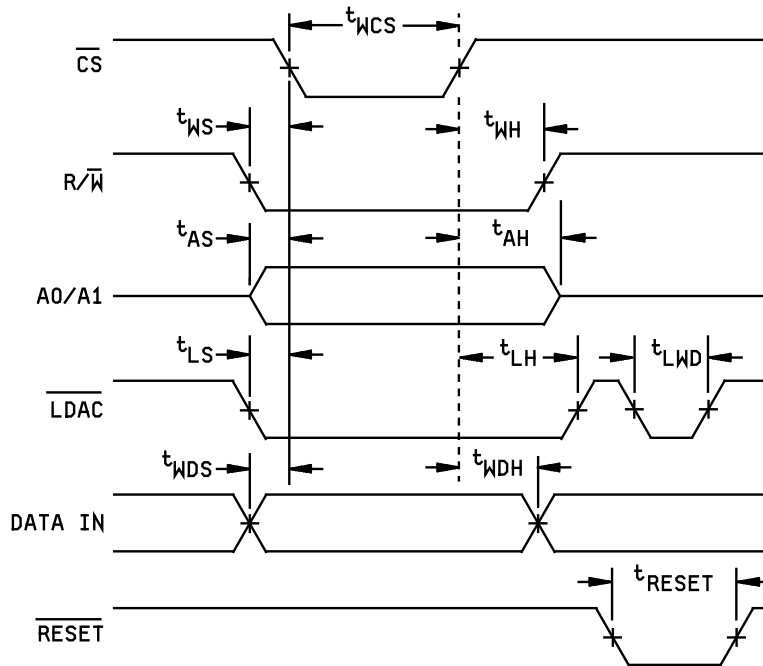

DATA WRITE (INPUT AND OUTPUT REGISTERS) TIMING

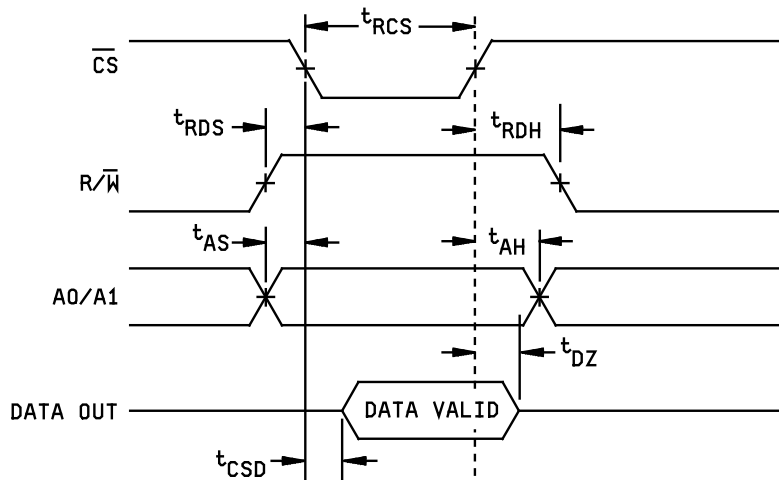

DATA OUTPUT (READ) TIMING

FIGURE 4. Timing waveforms.

**STANDARD
MICROCIRCUIT DRAWING**
DLA LAND AND MARITIME
COLUMBUS, OHIO 43218-3990

SIZE
A

5962-91764

REVISION LEVEL
C

SHEET

11

3.8 Notification of change for device class M. For device class M, notification to DLA Land and Maritime-VA of change of product (see 6.2 herein) involving devices acquired to this drawing is required for any change that affects this drawing.

3.9 Verification and review for device class M. For device class M, DLA Land and Maritime, DLA Land and Maritime's agent, and the acquiring activity retain the option to review the manufacturer's facility and applicable required documentation. Offshore documentation shall be made available onshore at the option of the reviewer.

3.10 Microcircuit group assignment for device class M. Device class M devices covered by this drawing shall be in microcircuit group number 92 (see MIL-PRF-38535, appendix A).

4. VERIFICATION

4.1 Sampling and inspection. For device classes Q and V, sampling and inspection procedures shall be in accordance with MIL-PRF-38535 or as modified in the device manufacturer's Quality Management (QM) plan. The modification in the QM plan shall not affect the form, fit, or function as described herein. For device class M, sampling and inspection procedures shall be in accordance with MIL-PRF-38535, appendix A.

4.2 Screening. For device classes Q and V, screening shall be in accordance with MIL-PRF-38535, and shall be conducted on all devices prior to qualification and technology conformance inspection. For device class M, screening shall be in accordance with method 5004 of MIL-STD-883, and shall be conducted on all devices prior to quality conformance inspection.

4.2.1 Additional criteria for device class M.

a. Burn-in test, method 1015 of MIL-STD-883.

(1) Test condition A, B, C, or D. The test circuit shall be maintained by the manufacturer under document revision level control and shall be made available to the preparing or acquiring activity upon request. The test circuit shall specify the inputs, outputs, biases, and power dissipation, as applicable, in accordance with the intent specified in method 1015 of MIL-STD-883.

(2) $T_A = +125^\circ\text{C}$, minimum.

b. Interim and final electrical test parameters shall be as specified in table II herein.

4.2.2 Additional criteria for device classes Q and V.

a. The burn-in test duration, test condition and test temperature, or approved alternatives shall be as specified in the device manufacturer's QM plan in accordance with MIL-PRF-38535. The burn-in test circuit shall be maintained under document revision level control of the device manufacturer's Technology Review Board (TRB) in accordance with MIL-PRF-38535 and shall be made available to the acquiring or preparing activity upon request. The test circuit shall specify the inputs, outputs, biases, and power dissipation, as applicable, in accordance with the intent specified in method 1015 of MIL-STD-883.

b. Interim and final electrical test parameters shall be as specified in table II herein.

c. Additional screening for device class V beyond the requirements of device class Q shall be as specified in MIL-PRF-38535, appendix B.

4.3 Qualification inspection for device classes Q and V. Qualification inspection for device classes Q and V shall be in accordance with MIL-PRF-38535. Inspections to be performed shall be those specified in MIL-PRF-38535 and herein for groups A, B, C, D, and E inspections (see 4.4.1 through 4.4.4).

4.4 Conformance inspection. Technology conformance inspection for classes Q and V shall be in accordance with MIL-PRF-38535 including groups A, B, C, D, and E inspections, and as specified herein. Quality conformance inspection for device class M shall be in accordance with MIL-PRF-38535, appendix A and as specified herein. Inspections to be performed for device class M shall be those specified in method 5005 of MIL-STD-883 and herein for groups A, B, C, D, and E inspections (see 4.4.1 through 4.4.4).

STANDARD MICROCIRCUIT DRAWING DLA LAND AND MARITIME COLUMBUS, OHIO 43218-3990	SIZE A		5962-91764
		REVISION LEVEL C	SHEET 12

4.4.1 Group A inspection.

- a. Tests shall be as specified in table II herein.
- b. Subgroups 5, 6, and 8 in table I, method 5005 of MIL-STD-883 shall be omitted.
- c. For device class M, subgroup 7 tests shall be sufficient to verify the truth table. For device classes Q and V, subgroup 7 shall include verifying the functionality of the device.

TABLE II. Electrical test requirements.

Test requirements	Subgroups (in accordance with MIL-STD-883, method 5005, table I)	Subgroups (in accordance with MIL-PRF-38535, table III)	
	Device class M	Device class Q	Device class V
Interim electrical parameters (see 4.2)	1	1	1
Final electrical parameters (see 4.2)	1, 2, 3 <u>1/</u>	1, 2, 3 <u>1/</u>	1, 2, 3 <u>1/</u>
Group A test requirements (see 4.4)	1, 2, 3, 4, 7, 9, 10, 11 <u>2/</u>	1, 2, 3, 4, 7, 9, 10, 11 <u>2/</u>	1, 2, 3, 4, 7, 9, 10, 11 <u>2/</u>
Group C end-point electrical parameters (see 4.4)	1	1	1
Group D end-point electrical parameters (see 4.4)	1	1	1
Group E end-point electrical parameters (see 4.4)	---	---	---

1/ PDA applies to subgroup 1.

2/ Subgroups 4, 9, 10, and 11, not tested, but shall be guaranteed to the limits specified in table I herein.

4.4.2 Group C inspection. The group C inspection end-point electrical parameters shall be as specified in table II herein.

4.4.2.1 Additional criteria for device class M. Steady-state life test conditions, method 1005 of MIL-STD-883:

- a. Test condition A, B, C, or D. The test circuit shall be maintained by the manufacturer under document revision level control and shall be made available to the preparing or acquiring activity upon request. The test circuit shall specify the inputs, outputs, biases, and power dissipation, as applicable, in accordance with the intent specified in method 1005 of MIL-STD-883.
- b. $T_A = +125^\circ\text{C}$, minimum.
- c. Test duration: 1,000 hours, except as permitted by method 1005 of MIL-STD-883.

4.4.2.2 Additional criteria for device classes Q and V. The steady-state life test duration, test condition and test temperature, or approved alternatives shall be as specified in the device manufacturer's QM plan in accordance with MIL-PRF-38535. The test circuit shall be maintained under document revision level control by the device manufacturer's TRB in accordance with MIL-PRF-38535 and shall be made available to the acquiring or preparing activity upon request. The test circuit shall specify the inputs, outputs, biases, and power dissipation, as applicable, in accordance with the intent specified in method 1005 of MIL-STD-883.

STANDARD MICROCIRCUIT DRAWING DLA LAND AND MARITIME COLUMBUS, OHIO 43218-3990	SIZE A		5962-91764
		REVISION LEVEL C	SHEET 13

4.4.3 Group D inspection. The group D inspection end-point electrical parameters shall be as specified in table II herein.

4.4.4 Group E inspection. Group E inspection is required only for parts intended to be marked as radiation hardness assured (see 3.5 herein).

- a. End-point electrical parameters shall be as specified in table II herein.
- b. For device classes Q and V, the devices or test vehicle shall be subjected to radiation hardness assured tests as specified in MIL-PRF-38535 for the RHA level being tested. For device class M, the devices shall be subjected to radiation hardness assured tests as specified in MIL-PRF-38535, appendix A for the RHA level being tested. All device classes must meet the postirradiation end-point electrical parameter limits as defined in table I at $T_A = +25^{\circ}\text{C} \pm 5^{\circ}\text{C}$, after exposure, to the subgroups specified in table II herein.

5. PACKAGING

5.1 Packaging requirements. The requirements for packaging shall be in accordance with MIL-PRF-38535 for device classes Q and V or MIL-PRF-38535, appendix A for device class M.

6. NOTES

6.1 Intended use. Microcircuits conforming to this drawing are intended for use for Government microcircuit applications (original equipment), design applications, and logistics purposes.

6.1.1 Replaceability. Microcircuits covered by this drawing will replace the same generic device covered by a contractor prepared specification or drawing.

6.1.2 Substitutability. Device class Q devices will replace device class M devices.

6.2 Configuration control of SMD's. All proposed changes to existing SMD's will be coordinated with the users of record for the individual documents. This coordination will be accomplished using DD Form 1692, Engineering Change Proposal.

6.3 Record of users. Military and industrial users should inform DLA Land and Maritime when a system application requires configuration control and which SMD's are applicable to that system. DLA Land and Maritime will maintain a record of users and this list will be used for coordination and distribution of changes to the drawings. Users of drawings covering microelectronic devices (FSC 5962) should contact DLA Land and Maritime-VA, telephone (614) 692-8108.

6.4 Comments. Comments on this drawing should be directed to DLA Land and Maritime-VA, Columbus, Ohio 43218-3990, or telephone (614) 692-0540.

6.5 Abbreviations, symbols, and definitions. The abbreviations, symbols, and definitions used herein are defined in MIL-PRF-38535 and MIL-HDBK-1331.

6.6 Sources of supply.

6.6.1 Sources of supply for device classes Q and V. Sources of supply for device classes Q and V are listed in MIL-HDBK-103 and QML-38535. The vendors listed in MIL-HDBK-103 and QML-38535 have submitted a certificate of compliance (see 3.6 herein) to DLA Land and Maritime-VA and have agreed to this drawing.

6.6.2 Approved sources of supply for device class M. Approved sources of supply for class M are listed in MIL-HDBK-103. The vendors listed in MIL-HDBK-103 have agreed to this drawing and a certificate of compliance (see 3.6 herein) has been submitted to and accepted by DLA Land and Maritime-VA.

STANDARD MICROCIRCUIT DRAWING DLA LAND AND MARITIME COLUMBUS, OHIO 43218-3990	SIZE A		5962-91764
		REVISION LEVEL C	SHEET 14

STANDARD MICROCIRCUIT DRAWING BULLETIN

DATE: 18-07-10

Approved sources of supply for SMD 5962-91764 are listed below for immediate acquisition information only and shall be added to MIL-HDBK-103 and QML-38535 during the next revision. MIL-HDBK-103 and QML-38535 will be revised to include the addition or deletion of sources. The vendors listed below have agreed to this drawing and a certificate of compliance has been submitted to and accepted by DLA Land and Maritime-VA. This information bulletin is superseded by the next dated revision of MIL-HDBK-103 and QML-38535. DLA Land and Maritime maintains an online database of all current sources of supply at <https://landandmaritimeapps.dla.mil/programs/smcr/>.

Standard microcircuit drawing PIN <u>1/</u>	Vendor CAGE number	Vendor similar PIN <u>2/</u>
5962-9176401MXA	24355	DAC8412AT/883
5962-9176402MXA	24355	DAC8412BT/883
5962-9176402M3A	24355	DAC8412BTC/883
5962-9176403MXA	24355	DAC8413AT/883
5962-9176404MXA	24355	DAC8413BT/883
5962-9176404M3A	24355	DAC8413BTC/883

1/ The lead finish shown for each PIN representing a hermetic package is the most readily available from the manufacturer listed for that part. If the desired lead finish is not listed contact the vendor to determine its availability.

2/ Caution. Do not use this number for item acquisition. Items acquired to this number may not satisfy the performance requirements of this drawing.

Vendor CAGE
number

24355

Vendor name
and address

Analog Devices
Rt 1 Industrial Park
PO Box 9106
Norwood, MA 02062
Point of contact: 804 Woburn Street
Wilmington, MA 01887-3462

The information contained herein is disseminated for convenience only and the Government assumes no liability whatsoever for any inaccuracies in the information bulletin.