

REVISIONS

LTR	DESCRIPTION	DATE (YR-MO-DA)	APPROVED
A	Changes in accordance with NOR 5962-R107-95.	95-04-12	M. A. Frye
B	Add case outline X. Update boilerplate. Editorial changes throughout. -rrp	98-02-19	Raymond Monnin
C	Update drawing to current requirements. Editorial changes throughout. - drw	05-02-01	Raymond Monnin
D	Redrawn. Update paragraphs to MIL-PRF-38535 requirements. - drw	17-02-23	Charles F. Saffle
E	Drawing updated to reflect current MIL-PRF-38535 requirements. -rrp	22-10-12	James R. Eschmeyer



Revision Status of Sheets

REV																				
SHEET																				
REV	E	E	E	E	E	E	E	E	E	E	E	E	E							
SHEET	1	2	3	4	5	6	7	8	9	10	11	12	13	14						

PMIC N/A			
<p>STANDARD MICROCIRCUIT DRAWING</p> <p>THIS DRAWING IS AVAILABLE FOR USE BY ALL DEPARTMENTS AND AGENCIES OF THE DEPARTMENT OF DEFENSE</p>	PREPARED BY RICK C. OFFICER CHECKED BY CHARLES E. BESORE	<p>DLA LAND AND MARITIME COLUMBUS, OHIO 43218-3990 https://www.dla.mil/LandandMaritime</p>	
	APPROVED BY MICHAEL A. FRYE	MICROCIRCUIT, LINEAR, CMOS QUAD DIFFERENTIAL LINE RECEIVER, MONOLITHIC SILICON	
	DRAWING APPROVAL DATE 91-09-11		
AMSC N/A	REVISION LEVEL E	SIZE A	CAGE CODE 67268
		SHEET 1 OF 14	

1. SCOPE

1.1 Scope. This drawing documents two product assurance class levels consisting of high reliability (device class Q and M) and space application (device class V). A choice of case outlines and lead finishes are available and are reflected in the Part or Identifying Number (PIN). When available, a choice of Radiation Hardness Assurance (RHA) levels is reflected in the PIN.

1.2 PIN. The PIN is as shown in the following example:

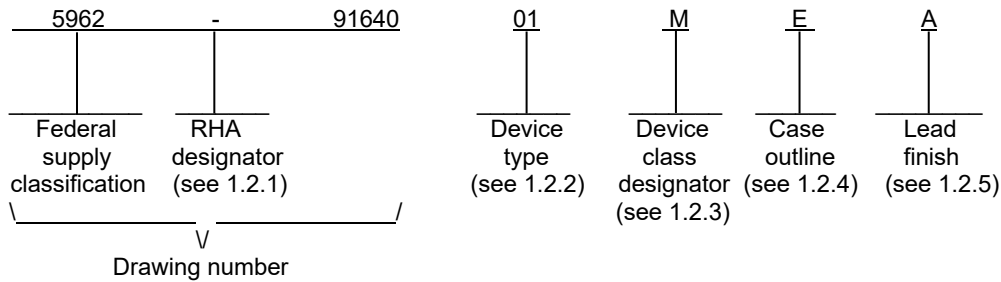

1.2.1 RHA designator. Device classes Q and V RHA marked devices meet the MIL-PRF-38535 specified RHA levels and are marked with the appropriate RHA designator. Device class M RHA marked devices meet the MIL-PRF-38535, appendix A specified RHA levels and are marked with the appropriate RHA designator. A dash (-) indicates a non-RHA device.

1.2.2 Device type(s). The device type(s) identify the circuit function as follows:

<u>Device type</u>	<u>Generic number</u>	<u>Circuit function</u>
01	26C32	CMOS quad differential line receiver

1.2.3 Device class designator. The device class designator is a single letter identifying the product assurance level as follows:

<u>Device class</u>	<u>Device requirements documentation</u>
M	Vendor self-certification to the requirements for MIL-STD-883 compliant, non-JAN class level B microcircuits in accordance with MIL-PRF-38535, appendix A
Q or V	Certification and qualification to MIL-PRF-38535

1.2.4 Case outlines. The case outlines are as designated in MIL-STD-1835 and as follows:

<u>Outline letter</u>	<u>Descriptive designator</u>	<u>Terminals</u>	<u>Package style</u>
E	GDIP1-T16 or CDIP2-T16	16	Dual-in-line
F	GDFP2-F16 or CDFP3-F16	16	Flat pack
X	See figure 1	16	Flat pack
2	CQCC1-N20	20	Square leadless chip carrier

1.2.5 Lead finish. The lead finish is as specified in MIL-PRF-38535 for device classes Q and V or MIL-PRF-38535, appendix A for device class M.

STANDARD MICROCIRCUIT DRAWING DLA LAND AND MARITIME COLUMBUS, OHIO 43218-3990	SIZE A		5962-91640
		REVISION LEVEL E	SHEET 2

1.3 Absolute maximum ratings. 1/

Supply voltage range (V_{CC})	7.0 V dc
Differential input voltage (V_{ID})	-11 V dc to +14 V dc
Maximum current per output	+25 mA
Enable input voltage (V_{IN})	7.0 V dc
Power dissipation (P_D): ($T_A = +25^\circ\text{C}$) 2/	
Case E	1375 mW
Case F	1000 mW
Case X	1339 mW
Case 2	1700 mW
Storage temperature	-65°C to +150°C
Lead temperature (soldering, 4 seconds).....	260°C
Junction temperature (T_J).....	150°C
Thermal resistance, junction-to-case (θ_{JC}):	
Cases E, F, and 2	See MIL-STD-1835
Case X	9°C/W
Thermal resistance, junction-to-ambient (θ_{JA}):	
Case E	+100°C/W
Case F	+150°C/W
Case X	+112°C/W
Case 2	+85°C/W

1.4 Recommended operating conditions.

Supply voltage range (V_{CC})	4.5 V dc to 5.5 V dc
Ambient operating temperature range (T_A)	-55°C to +125°C
Input hysteresis (V_{HYST}).....	60 mV typical

2. APPLICABLE DOCUMENTS

2.1 Government specification, standards, and handbooks. The following specification, standards, and handbooks form a part of this drawing to the extent specified herein. Unless otherwise specified, the issues of these documents are those cited in the solicitation or contract.

DEPARTMENT OF DEFENSE SPECIFICATION

MIL-PRF-38535 - Integrated Circuits, Manufacturing, General Specification for.

DEPARTMENT OF DEFENSE STANDARDS

MIL-STD-883 - Test Method Standard Microcircuits.
MIL-STD-1835 - Interface Standard Electronic Component Case Outlines.

DEPARTMENT OF DEFENSE HANDBOOKS

MIL-HDBK-103 - List of Standard Microcircuit Drawings.
MIL-HDBK-780 - Standard Microcircuit Drawings.

(Copies of these documents are available online at <https://quicksearch.dla.mil/>).

1/ Stresses above the absolute maximum rating may cause permanent damage to the device. Extended operation at the maximum levels may degrade performance and affect reliability.
2/ 25°C, derate at a factor of 11 mW/°C for cases E and 2, and 8.9 mW/°C for case F and X.

STANDARD MICROCIRCUIT DRAWING DLA LAND AND MARITIME COLUMBUS, OHIO 43218-3990	SIZE A		5962-91640
		REVISION LEVEL E	SHEET 3

2.2 Order of precedence. In the event of a conflict between the text of this drawing and the references cited herein, the text of this drawing takes precedence. Nothing in this document, however, supersedes applicable laws and regulations unless a specific exemption has been obtained.

3. REQUIREMENTS

3.1 Item requirements. The individual item requirements for device classes Q and V shall be in accordance with MIL-PRF-38535 as specified herein, or as modified in the device manufacturer's Quality Management (QM) plan. The modification in the QM plan shall not affect the form, fit, or function as described herein. The individual item requirements for device class M shall be in accordance with MIL-PRF-38535, appendix A for non-JAN class level B devices and as specified herein.

3.2 Design, construction, and physical dimensions. The design, construction, and physical dimensions shall be as specified in MIL-PRF-38535 and herein for device classes Q and V or MIL-PRF-38535, appendix A and herein for device class M.

3.2.1 Case outlines. The case outlines shall be in accordance with 1.2.4 herein and figure 1.

3.2.2 Terminal connections. The terminal connections shall be as specified on figure 2.

3.2.3 Truth table. The truth table shall be as specified on figure 3.

3.2.4 Logic diagram. The logic diagram shall be as specified on figure 4.

3.3 Electrical performance characteristics and postirradiation parameter limits. Unless otherwise specified herein, the electrical performance characteristics and postirradiation parameter limits are as specified in table I and shall apply over the full ambient operating temperature range.

3.4 Electrical test requirements. The electrical test requirements shall be the subgroups specified in table II. The electrical tests for each subgroup are defined in table I.

3.5 Marking. The part shall be marked with the PIN listed in 1.2 herein. In addition, the manufacturer's PIN may also be marked. For packages where marking of the entire SMD PIN number is not feasible due to space limitations, the manufacturer has the option of not marking the "5962-" on the device. For RHA product using this option, the RHA designator shall still be marked. Marking for device classes Q and V shall be in accordance with MIL-PRF-38535. Marking for device class M shall be in accordance with MIL-PRF-38535, appendix A.

3.5.1 Certification/compliance mark. The certification mark for device classes Q and V shall be a "QML" or "Q" as required in MIL-PRF-38535. The compliance mark for device class M shall be a "C" as required in MIL-PRF-38535, appendix A.

3.6 Certificate of compliance. For device classes Q and V, a certificate of compliance shall be required from a QML-38535 listed manufacturer in order to supply to the requirements of this drawing (see 6.6.1 herein). For device class M, a certificate of compliance shall be required from a manufacturer in order to be listed as an approved source of supply in MIL-HDBK-103 (see 6.6.2 herein). The certificate of compliance submitted to DLA Land and Maritime-VA prior to listing as an approved source of supply for this drawing shall affirm that the manufacturer's product meets, for device classes Q and V, the requirements of MIL-PRF-38535 and herein or for device class M, the requirements of MIL-PRF-38535, appendix A and herein.

3.7 Certificate of conformance. A certificate of conformance as required for device classes Q and V in MIL-PRF-38535 or for device class M in MIL-PRF-38535, appendix A shall be provided with each lot of microcircuits delivered to this drawing.

3.8 Notification of change for device class M. For device class M, notification to DLA Land and Maritime-VA of change of product (see 6.2 herein) involving devices acquired to this drawing is required for any change that affects this drawing.

3.9 Verification and review for device class M. For device class M, DLA Land and Maritime, DLA Land and Maritime's agent, and the acquiring activity retain the option to review the manufacturer's facility and applicable required documentation. Offshore documentation shall be made available onshore at the option of the reviewer.

3.10 Microcircuit group assignment for device class M. Device class M devices covered by this drawing shall be in microcircuit group number 77 (see MIL-PRF-38535, appendix A).

STANDARD MICROCIRCUIT DRAWING DLA LAND AND MARITIME COLUMBUS, OHIO 43218-3990	SIZE A		5962-91640
		REVISION LEVEL E	SHEET 4

TABLE I. Electrical performance characteristics.

Test	Symbol	Conditions ^{1/} -55°C ≤ T _A ≤ +125°C 4.5 V ≤ V _{CC} ≤ 5.5 V unless otherwise specified	Group A subgroups	Device type	Limits		Unit
					Min	Max	
Logical 1 input voltage	V _{IH}		1, 2, 3	01	2.0		V
Logical 0 input voltage	V _{IL}		1, 2, 3	01		0.8	V
Logical 1 output voltage	V _{OH}	V _{ID} = +200 mV, V _{CC} = 4.5 V, I _{OUT} = -6.0 mA	1, 2, 3	01	3.8		V
Logical 0 output voltage	V _{OL}	V _{CC} = 5.5 V, V _{ID} = -200 mV, I _{OUT} = 6.0 mA	1, 2, 3	01		0.3	V
Minimum differential input voltage	V _{TH}	V _{CC} = 5.0 V, V _{OUT} = V _{OH} or 0.45 V, -7 V < V _{CM} < +7 V	1, 2, 3	01	-200	+200	mV
Input current (under test)	I _{IN}	V _{IN} = +10 V, V _{CC} = 5.0 V, other input = GND	1, 2, 3	01		+1.8	mA
		V _{IN} = -10 V, V _{CC} = 5.0 V, other input = GND				-2.7	
Maximum three state output leakage current	I _{OZ}	V _{OUT} = V _{CC} or GND, ENABLE = V _{IL} , $\overline{\text{ENABLE}}$ = V _{IH}	1, 2, 3	01	-5.0	+5.0	μA
Maximum enable input current	I _I	V _{IN} = 2.7 V to 0.4 V	1, 2, 3	01	-100	+20	μA
Input resistance	R _{IN}	-7 V < V _{CM} < +7 V, one input ac GND	1, 2, 3	01	4.0	25	kΩ
Quiescent power supply current	I _{CC}	V _{ID} = +1 V, V _{CC} = 5.5 V	1, 2, 3	01		25	mA
Functional tests		See 4.4.1c	7, 8	01			
Propagation delay input to output	t _{PLH}	V _{CM} = 0 V, C _L = 50 pF, V _{ID} = 2.5 V, See figure 5	9, 10, 11	01		35	ns
	t _{PHL}					35	
Output rise time	t _R	V _{CM} = 0 V, C _L = 50 pF, See figure 5	9, 10, 11	01		10	ns
Output fall time	t _F	V _{CM} = 0 V, C _L = 50 pF, See figure 5	9, 10, 11	01		9	ns
Propagation delay enable to output	t _{PLZ}	R _L = 1 kΩ, C _L = 50 pF, V _{ID} = 2.5 V, See figures 5 and 6	9, 10, 11	01		29	ns
	t _{PHZ}					29	
	t _{PZL}					29	
	t _{PZH}					29	

^{1/} All currents into device pins are positive; all currents out of device pins are negative. All voltages are referenced to ground unless otherwise specified.

**STANDARD
MICROCIRCUIT DRAWING**
DLA LAND AND MARITIME
COLUMBUS, OHIO 43218-3990

SIZE
A

REVISION LEVEL
E

5962-91640

SHEET **5**

Case X

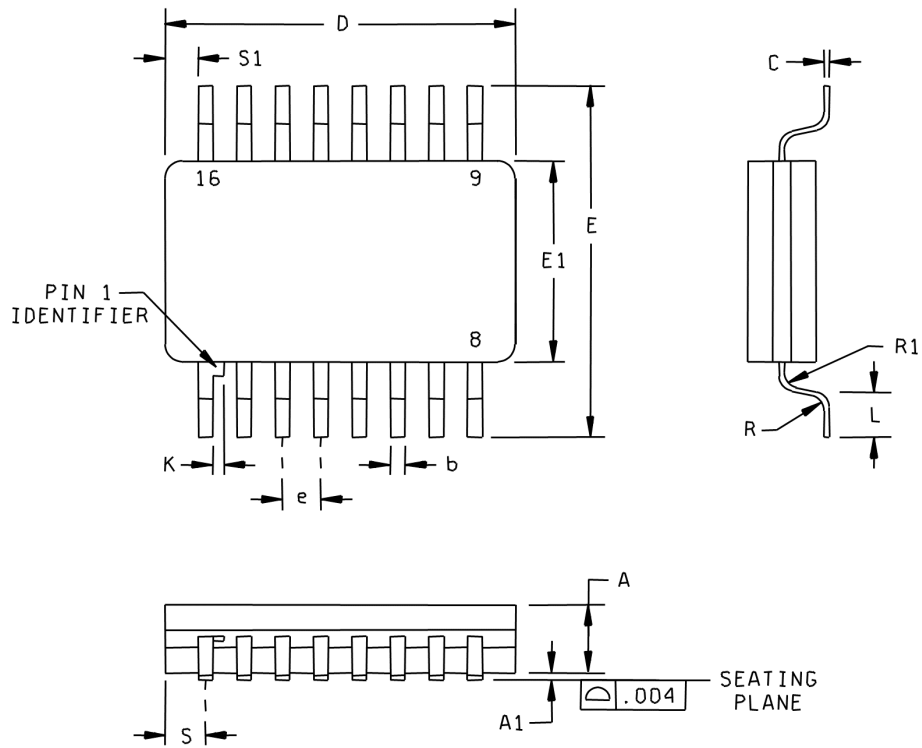

FIGURE 1. Case outline.

**STANDARD
MICROCIRCUIT DRAWING**
DLA LAND AND MARITIME
COLUMBUS, OHIO 43218-3990

SIZE
A

5962-91640

REVISION LEVEL
E

SHEET **6**

Case X – continued

Symbol	Inches		Millimeters		Notes
	Min	Max	Min	Max	
A	.050	.080	1.27	2.03	
A1	.004	.012	0.10	0.30	
b	.015	.019	0.38	0.48	2
C	.004	.008	0.10	0.20	2
D	---	.390	---	9.91	
E	.400	.420	10.16	10.67	
E1	.245	.270	6.22	6.86	
e	.050 BSC		1.27 BSC		
K	.008	.012	0.20	0.30	
L	.037	.043	0.94	1.09	
R	.013	.017	0.33	0.43	
R1	.013	.017	0.33	0.43	
S	---	.018	---	0.46	
S1	.005	---	0.13	---	

NOTES:

1. The U.S. government preferred system of measurement is the metric SI system. However, since this item was originally designed using inch-pound units of measurement, in the event of conflict between the metric and inch-pound units, the inch-pound units shall take precedence.
2. Maximum limits may be increased by .003 inches after lead finish is applied.

FIGURE 1. Case outline – continued.

STANDARD MICROCIRCUIT DRAWING DLA LAND AND MARITIME COLUMBUS, OHIO 43218-3990	SIZE A		5962-91640
		REVISION LEVEL E	SHEET 7

Device type	01	
Case outline	E, F, and X	2
Terminal number	Terminal symbol	
1	INPUT A1-	NC
2	INPUT A2+	INPUT A1-
3	OUTPUT A	INPUT A2+
4	ENABLE	OUTPUT A
5	OUTPUT C	ENABLE
6	INPUT C2+	NC
7	INPUT C1-	OUTPUT B
8	GND	INPUT B2+
9	INPUT D1-	INPUT B1-
10	INPUT D2+	GND
11	OUTPUT D	NC
12	$\overline{\text{ENABLE}}$	INPUT C1-
13	OUTPUT B	INPUT C2+
14	INPUT B2+	OUTPUT C
15	INPUT B1-	$\overline{\text{ENABLE}}$
16	V _{cc}	NC
17	---	OUTPUT D
18	---	INPUT D2+
19	---	INPUT D1-
20	---	V _{cc}

NC = No connection

FIGURE 2. Terminal connections.

STANDARD MICROCIRCUIT DRAWING DLA LAND AND MARITIME COLUMBUS, OHIO 43218-3990	SIZE A		5962-91640
		REVISION LEVEL E	SHEET 8

ENABLE	$\overline{\text{ENABLE}}$	INPUT	OUTPUT
0	1	X	HI-Z
(See note)		$V_{ID} \geq V_{TH} (\text{max})$	1
		$V_{ID} \leq V_{TH} (\text{min})$	0
		Open	1
		$V_{TH} (\text{min}) \leq V_{ID} \leq V_{TH} (\text{max})$	INDETERMINATE

HI-Z = THREE STATE
X = Don't care

NOTE: Input conditions may be any combination not defined for $\overline{\text{ENABLE}}$ and ENABLE.

FIGURE 3. Truth table.

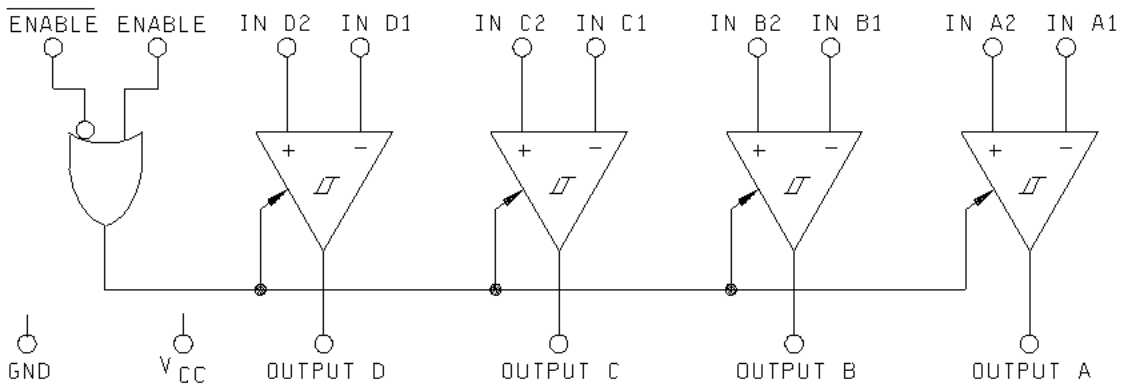

FIGURE 4. Logic diagram.

**STANDARD
MICROCIRCUIT DRAWING**
DLA LAND AND MARITIME
COLUMBUS, OHIO 43218-3990

SIZE
A

5962-91640

REVISION LEVEL
E

SHEET **9**

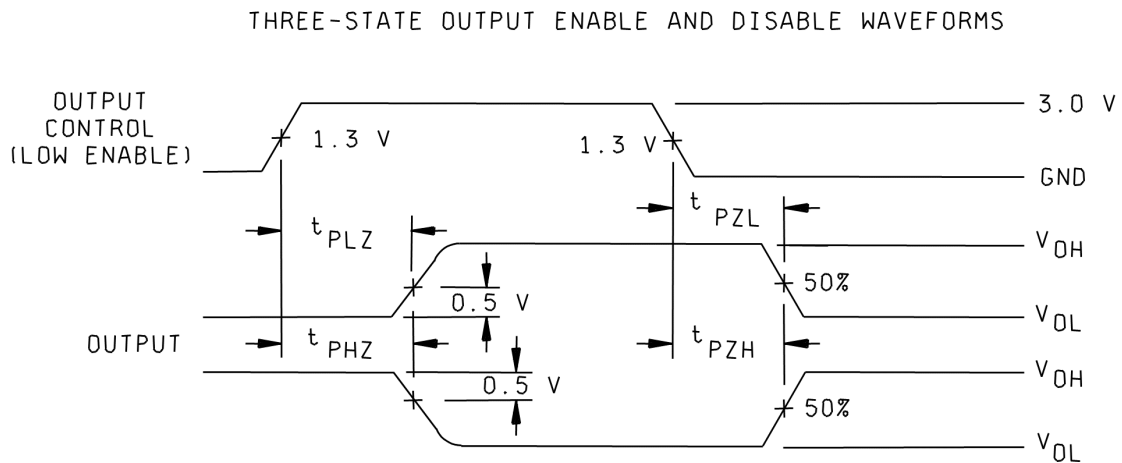
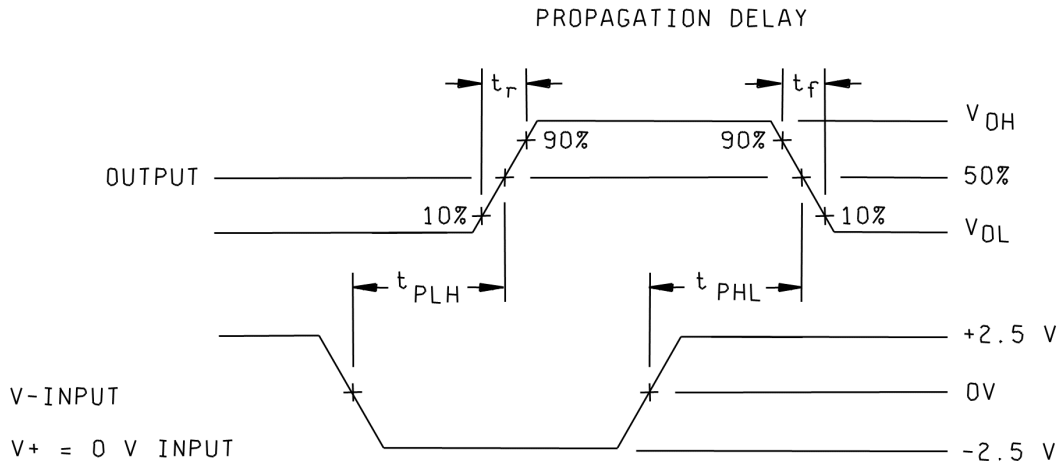

FIGURE 5. Timing waveforms.

**STANDARD
MICROCIRCUIT DRAWING**
DLA LAND AND MARITIME
COLUMBUS, OHIO 43218-3990

SIZE
A

5962-91640

REVISION LEVEL
E

SHEET **10**

THREE STATE OUTPUT TESTS

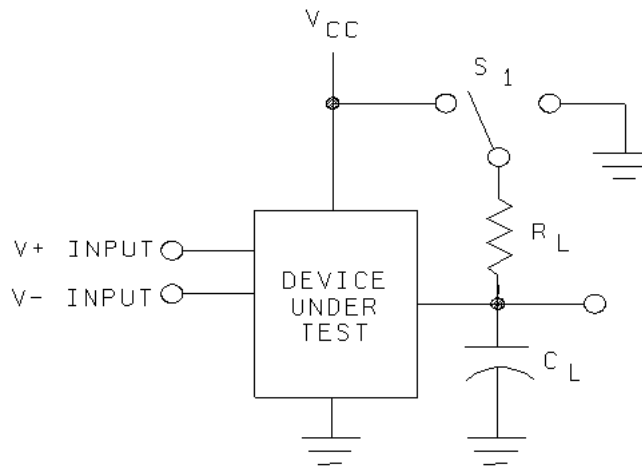

NOTES:

- C_L includes load and test jig capacitance.
- $S_1 = V_{CC}$ for t_{PZL} and t_{PLZ} measurements.
- $S_1 = GND$ for t_{PZH} and t_{PHZ} measurements.

FIGURE 6. Test circuit.

**STANDARD
MICROCIRCUIT DRAWING**
DLA LAND AND MARITIME
COLUMBUS, OHIO 43218-3990

SIZE
A

5962-91640

REVISION LEVEL
E

SHEET **11**

4. VERIFICATION

4.1 Sampling and inspection. For device classes Q and V, sampling and inspection procedures shall be in accordance with MIL-PRF-38535 or as modified in the device manufacturer's Quality Management (QM) plan. The modification in the QM plan shall not affect the form, fit, or function as described herein. For device class M, sampling and inspection procedures shall be in accordance with MIL-PRF-38535, appendix A.

4.2 Screening. For device classes Q and V, screening shall be in accordance with MIL-PRF-38535, and shall be conducted on all devices prior to qualification and technology conformance inspection. For device class M, screening shall be in accordance with method 5004 of MIL-STD-883, and shall be conducted on all devices prior to quality conformance inspection.

4.2.1 Additional criteria for device class M.

a. Burn-in test, method 1015 of MIL-STD-883.

(1) Test condition A, B, C, or D. The test circuit shall be maintained by the manufacturer under document revision level control and shall be made available to the preparing or acquiring activity upon request. The test circuit shall specify the inputs, outputs, biases, and power dissipation, as applicable, in accordance with the intent specified in method 1015 of MIL-STD-883.

(2) TA = +125°C, minimum.

b. Interim and final electrical test parameters shall be as specified in table II herein.

4.2.2 Additional criteria for device classes Q and V.

a. The burn-in test duration, test condition and test temperature, or approved alternatives shall be as specified in the device manufacturer's QM plan in accordance with MIL-PRF-38535. The burn-in test circuit shall be maintained under document revision level control of the device manufacturer's Technology Review Board (TRB) in accordance with MIL-PRF-38535 and shall be made available to the acquiring or preparing activity upon request. The test circuit shall specify the inputs, outputs, biases, and power dissipation, as applicable, in accordance with the intent specified in method 1015 of MIL-STD-883.

b. Interim and final electrical test parameters shall be as specified in table II herein.

c. Additional screening for device class V beyond the requirements of device class Q shall be as specified in MIL-PRF-38535, appendix B.

4.3 Qualification inspection for device classes Q and V. Qualification inspection for device classes Q and V shall be in accordance with MIL-PRF-38535. Inspections to be performed shall be those specified in MIL-PRF-38535 and herein for groups A, B, C, D, and E inspections (see 4.4.1 through 4.4.4).

4.4 Conformance inspection. Technology conformance inspection for classes Q and V shall be in accordance with MIL-PRF-38535 including groups A, B, C, D, and E inspections, and as specified herein. Quality conformance inspection for device class M shall be in accordance with MIL-PRF-38535, appendix A and as specified herein. Inspections to be performed for device class M shall be those specified in method 5005 of MIL-STD-883 and herein for groups A, B, C, D, and E inspections (see 4.4.1 through 4.4.4).

4.4.1 Group A inspection.

a. Tests shall be as specified in table II herein.

b. Subgroups 4, 5, and 6 in table I, method 5005 of MIL-STD-883 shall be omitted.

c. For device class M, subgroups 7 and 8 tests shall be sufficient to verify the truth table. For device classes Q and V, subgroups 7 and 8 shall include verifying the functionality of the device.

STANDARD MICROCIRCUIT DRAWING DLA LAND AND MARITIME COLUMBUS, OHIO 43218-3990	SIZE A		5962-91640
		REVISION LEVEL E	SHEET 12

TABLE II. Electrical test requirements.

Test requirements	Subgroups (in accordance with MIL-STD-883, method 5005, table I)	Subgroups (in accordance with MIL-PRF-38535, table III)	
	Device class M	Device class Q	Device class V
Interim electrical parameters (see 4.2)	1	---	1
Final electrical parameters (see 4.2)	1, 2, 3, 9 <u>1/</u>	1, 2, 3, 9 <u>1/</u>	1, 2, 3, 9 <u>1/</u>
Group A test requirements (see 4.4)	1, 2, 3, 7, 8, 9, 10, 11	1, 2, 3, 7, 8, 9, 10, 11	1, 2, 3, 7, 8, 9, 10, 11
Group C end-point electrical parameters (see 4.4)	1, 2, 3	1, 2, 3	1, 2, 3
Group D end-point electrical parameters (see 4.4)	1, 2, 3	1, 2, 3	1, 2, 3
Group E end-point electrical parameters (see 4.4)	---	---	---

1/ PDA applies to subgroup 1.

4.4.2 Group C inspection. The group C inspection end-point electrical parameters shall be as specified in table II herein.

4.4.2.1 Additional criteria for device class M. Steady-state life test conditions, method 1005 of MIL-STD-883:

a. Test condition A, B, C, or D. The test circuit shall be maintained by the manufacturer under document revision level control and shall be made available to the preparing or acquiring activity upon request. The test circuit shall specify the inputs, outputs, biases, and power dissipation, as applicable, in accordance with the intent specified in method 1005 of MIL-STD-883.

b. TA = +125°C, minimum.

c. Test duration: 1,000 hours, except as permitted by method 1005 of MIL-STD-883.

4.4.2.2 Additional criteria for device classes Q and V. The steady-state life test duration, test condition and test temperature, or approved alternatives shall be as specified in the device manufacturer's QM plan in accordance with MIL-PRF-38535. The test circuit shall be maintained under document revision level control by the device manufacturer's TRB in accordance with MIL-PRF-38535 and shall be made available to the acquiring or preparing activity upon request. The test circuit shall specify the inputs, outputs, biases, and power dissipation, as applicable, in accordance with the intent specified in method 1005 of MIL-STD-883.

4.4.3 Group D inspection. The group D inspection end-point electrical parameters shall be as specified in table II herein.

STANDARD MICROCIRCUIT DRAWING DLA LAND AND MARITIME COLUMBUS, OHIO 43218-3990	SIZE A		5962-91640
		REVISION LEVEL E	SHEET 13

4.4.4 Group E inspection. Group E inspection is required only for parts intended to be marked as radiation hardness assured (see 3.5 herein).

- a. End-point electrical parameters shall be as specified in table II herein.
- b. For device classes Q and V, the devices or test vehicle shall be subjected to radiation hardness assured tests as specified in MIL-PRF-38535 for the RHA level being tested. For device class M, the devices shall be subjected to radiation hardness assured tests as specified in MIL-PRF-38535, appendix A for the RHA level being tested. All device classes must meet the postirradiation end-point electrical parameter limits as defined in table I at TA = +25°C ±5°C, after exposure, to the subgroups specified in table II herein.

5. PACKAGING

5.1 Packaging requirements. The requirements for packaging shall be in accordance with MIL-PRF-38535 for device classes Q and V or MIL-PRF-38535, appendix A for device class M.

6. NOTES

6.1 Intended use. Microcircuits conforming to this drawing are intended for use for Government microcircuit applications (original equipment), design applications, and logistics purposes.

6.1.1 Replaceability. Microcircuits covered by this drawing will replace the same generic device covered by a contractor prepared specification or drawing.

6.1.2 Substitutability. Device class Q devices will replace device class M devices.

6.2 Configuration control of SMD's. All proposed changes to existing SMD's will be coordinated with the users of record for the individual documents. This coordination will be accomplished using DD Form 1692, Engineering Change Proposal, or email communication.

6.3 Record of users. Military and industrial users should inform DLA Land and Maritime when a system application requires configuration control and which SMD's are applicable to that system. DLA Land and Maritime will maintain a record of users and this list will be used for coordination and distribution of changes to the drawings. Users of drawings covering microelectronic devices (FSC 5962) should contact DLA Land and Maritime-VA, telephone (614) 692-8108.

6.4 Comments. Comments on this drawing should be directed to DLA Land and Maritime-VA, Columbus, Ohio 43218-3990, or telephone (614) 692-0591.

6.5 Abbreviations, symbols, and definitions. The abbreviations, symbols, and definitions used herein are defined in MIL-PRF-38535 and MIL-HDBK-1331.

6.6 Sources of supply.

6.6.1 Sources of supply for device classes Q and V. Sources of supply for device classes Q and V are listed in MIL-HDBK-103 and QML-38535. The vendors listed in MIL-HDBK-103 and QML-38535 have submitted a certificate of compliance (see 3.6 herein) to DLA Land and Maritime-VA and have agreed to this drawing.

6.6.2 Approved sources of supply for device class M. Approved sources of supply for class M are listed in MIL-HDBK-103. The vendors listed in MIL-HDBK-103 have agreed to this drawing and a certificate of compliance (see 3.6 herein) has been submitted to and accepted by DLA Land and Maritime-VA.

STANDARD MICROCIRCUIT DRAWING DLA LAND AND MARITIME COLUMBUS, OHIO 43218-3990	SIZE A		5962-91640
		REVISION LEVEL E	SHEET 14

STANDARD MICROCIRCUIT DRAWING BULLETIN

DATE: 22-10-12

Approved sources of supply for SMD 5962-91640 are listed below for immediate acquisition information only and shall be added to MIL-HDBK-103 and QML-38535 during the next revision. MIL-HDBK-103 and QML-38535 will be revised to include the addition or deletion of sources. The vendors listed below have agreed to this drawing and a certificate of compliance has been submitted to and accepted by DLA Land and Maritime-VA. This information bulletin is superseded by the next dated revision of MIL-HDBK-103 and QML-38535. DLA Land and Maritime maintains an online database of all current sources of supply at <https://landandmaritimeapps.dla.mil/programs/smcr/>.

Standard microcircuit drawing PIN <u>1/</u>	Vendor CAGE number	Vendor similar PIN <u>2/</u>
5962-9164001MEA	01295	DS26C32AMJ/883
5962-9164001MFA	01295	DS26C32AMW/883
5962-9164001MXA	01295	DS26C32AMWG/883
5962-9164001M2A	01295	DS26C32AME/883
5962-9164001QEA	01295	AM26C32MJB
5962-9164001QFA	01295	AM26C32MWB
5962-9164001Q2A	01295	AM26C32MFKB

- 1/ The lead finish shown for each PIN representing a hermetic package is the most readily available from the manufacturer listed for that part. If the desired lead finish is not listed contact the vendor to determine its availability.
- 2/ Caution. Do not use this number for item acquisition. Items acquired to this number may not satisfy the performance requirements of this drawing.

Vendor CAGE
number

01295

Vendor name
and address

Texas Instruments, Inc.
Semiconductor Group
8505 Forest Ln.
PO Box 660199
Dallas, TX 75243

The information contained herein is disseminated for convenience only and the Government assumes no liability whatsoever for any inaccuracies in the information bulletin.