

REVISIONS			
LTR	DESCRIPTION	DATE (YR-MO-DA)	APPROVED
B	Table I, for device type 01 only, add reset voltage level test. Changes in accordance with N.O.R. 5962-R063-93.	93-01-19	M. A. FRYE
C	Add device type 05. Add vendor CAGE 27014. Make changes to 1.3, 1.4, table I, figures 1, 3, 4, 5, and 6.	93-05-10	M. A. FRYE
D	Sheet 12, figure 2, device types 03, 04, and 05, for threshold voltage > 2/3 (VDD); change RESET from "low" to "high". Changes in accordance with N.O.R. 5962-R053-94.	94-06-24	M. A. FRYE
E	Redrawn with changes. Technical and editorial changes throughout.	94-10-28	M. A. FRYE
F	Make change to ICEX test for device type 05 as specified under table I. - ro	98-01-06	R. MONNIN
G	Make change to VOH and VOL tests for device type 05 as specified under table I. - rrp	00-12-21	R. MONNIN
H	Drawing updated to reflect current requirements. - rrp	04-11-01	R. MONNIN
J	Update boilerplate paragraphs to current MIL-PRF-38535 requirements. - ro	11-02-15	C. SAFFLE
K	Update document paragraphs to current MIL-PRF-38535 requirements. - ro	17-03-14	C. SAFFLE
L	Drawing updated to reflect current MIL-PRF-38535 requirements. -rrp	23-01-23	J. ESCHMEYER



THE ORIGINAL FIRST SHEET OF THIS DRAWING HAS BEEN REPLACED.

Revision Status of Sheets																				
REV																				
SHEET																				
REV	L	L	L	L	L	L	L	L	L	L	L	L	L	L	L	L	L	L	L	L
SHEET	1	2	3	4	5	6	7	8	9	10	11	12	13	14	15					

PMIC N/A		PREPARED BY GARY ZAHN CHECKED BY CHARLES E. BESORE APPROVED BY MICHAEL A. FRYE DRAWING APPROVAL DATE 89-12-04		DLA LAND AND MARITIME COLUMBUS, OHIO 43218-3990 https://www.dla.mil/LandandMaritime MICROCIRCUIT, LINEAR, CMOS, PRECISION TIMERS, MONOLITHIC SILICON	
STANDARD MICROCIRCUIT DRAWING THIS DRAWING IS AVAILABLE FOR USE BY ALL DEPARTMENTS AND AGENCIES OF THE DEPARTMENT OF DEFENSE		REVISION LEVEL L		SIZE A CAGE CODE 67268 5962-89503	
AMSC N/A		SHEET 1 OF 15			

1. SCOPE

1.1 Scope. This drawing describes device requirements for MIL-STD-883 compliant, non-JAN class level B microcircuits in accordance with MIL-PRF-38535, appendix A.

1.2 Part or Identifying Number (PIN). The complete PIN is as shown in the following example:

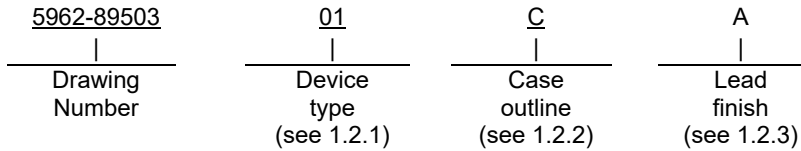

1.2.1 Device type(s). The device type(s) identify the circuit function as follows:

<u>Device type</u>	<u>Generic number</u>	<u>Circuit function</u>
01	TLC555	CMOS, precision timer, single
02	TLC556	CMOS, precision timer, dual
03	7555	CMOS, low power, precision timer, single
04	7556	CMOS, low power, precision timer, dual
05	LMC555	CMOS, low voltage, precision timer, single

1.2.2 Case outlines. The case outlines are as designated in MIL-STD-1835 and as follows:

<u>Outline letter</u>	<u>Descriptive designator</u>	<u>Terminals</u>	<u>Package style</u>
C	GDIP1-T14 or CDIP2-T14	14	Dual-in-line
G	MACY1-X8	8	Can
P	GDIP1-T8 or CDIP2-T8	8	Dual-in-line
2	CQCC1-N20	20	Square leadless chip carrier

1.2.3 Lead finish. The lead finish is as specified in MIL-PRF-38535, appendix A.

1.3 Absolute maximum ratings.

Supply voltage (VDD):	
Device types 01-04	18 V dc
Device type 05	15 V dc
Input voltage range	-0.3 V to VDD (+0.3 V)
Output sink current:	
Device types 01 and 02	150 mA
Device types 03 and 04	20 mA
Device type 05	100 mA
Output source current:	
Device types 01 and 02	15 mA
Device types 03 and 04	0.8 mA
Device type 05	10 mA
Storage temperature range	-65°C to +150°C
Lead temperature (soldering, 10 seconds)	+300°C
Junction temperature (T _J)	+175°C

STANDARD MICROCIRCUIT DRAWING DLA LAND AND MARITIME COLUMBUS, OHIO 43218-3990	SIZE A		5962-89503
		REVISION LEVEL L	SHEET 2

1.3 Absolute maximum ratings – continued.

Power dissipation (PD): (TA = +125°C):

Device types 01-04:

Cases C and 2	550 mW
Case G	23 mW
Case P	420 mW

Device type 05:

Cases C, G, P, and 2	550 mW
----------------------------	--------

Thermal resistance, junction-to-case (θ_{JC}):

Cases C and P	28°C/W
---------------------	--------

Case G:

Device types 01-04	70°C/W
Device type 05	30°C/W

Case 2	20°C/W
--------------	--------

Thermal resistance, junction-to-ambient (θ_{JA}):

Cases C and 2	91°C/W
---------------------	--------

Case G:

Device types 01-04	150°C/W
Device type 05	180°C/W

Case P:

Device types 01-04	119°C/W
Device type 05	125°C/W

1.4 Recommended operating conditions.

Supply voltage range (VDD):

Device types 01-02	+5.0 V dc to +15.0 V dc
Device types 03-04	+5.0 V dc to +18.0 V dc
Device type 05	+1.5 V dc to +15.0 V dc

Ambient operating temperature range (TA)	-55°C to +125°C
--	-----------------

2. APPLICABLE DOCUMENTS

2.1 Government specification, standards, and handbooks. The following specification, standards, and handbooks form a part of this drawing to the extent specified herein. Unless otherwise specified, the issues of these documents are those cited in the solicitation or contract.

DEPARTMENT OF DEFENSE SPECIFICATION

MIL-PRF-38535 - Integrated Circuits, Manufacturing, General Specification for.

DEPARTMENT OF DEFENSE STANDARDS

MIL-STD-883 - Test Method Standard Microcircuits.
 MIL-STD-1835 - Interface Standard Electronic Component Case Outlines.

DEPARTMENT OF DEFENSE HANDBOOKS

MIL-HDBK-103 - List of Standard Microcircuit Drawings.
 MIL-HDBK-780 - Standard Microcircuit Drawings.

(Copies of these documents are available online at <https://quicksearch.dla.mil/>).

STANDARD MICROCIRCUIT DRAWING DLA LAND AND MARITIME COLUMBUS, OHIO 43218-3990	SIZE A		5962-89503
		REVISION LEVEL L	SHEET 3

2.2 Order of precedence. In the event of a conflict between the text of this drawing and the references cited herein, the text of this drawing takes precedence. Nothing in this document, however, supersedes applicable laws and regulations unless a specific exemption has been obtained.

3. REQUIREMENTS

3.1 Item requirements. The individual item requirements shall be in accordance with MIL-PRF-38535, appendix A for non-JAN class level B devices and as specified herein. Product built to this drawing that is produced by a Qualified Manufacturer Listing (QML) certified and qualified manufacturer or a manufacturer who has been granted transitional certification to MIL-PRF-38535 may be processed as QML product in accordance with the manufacturers approved program plan and qualifying activity approval in accordance with MIL-PRF-38535. This QML flow as documented in the Quality Management (QM) plan may make modifications to the requirements herein. These modifications shall not affect form, fit, or function of the device. These modifications shall not affect the PIN as described herein. A "Q" or "QML" certification mark in accordance with MIL-PRF-38535 is required to identify when the QML flow option is used.

3.2 Design, construction, and physical dimensions. The design, construction, and physical dimensions shall be as specified in MIL-PRF-38535, appendix A and herein.

3.2.1 Case outline. The case outline shall be in accordance with 1.2.2 herein.

3.2.2 Terminal connections. The terminal connections shall be as specified on figure 1.

3.2.3 Block diagram and circuit operation table. The block diagram and circuit operation table shall be as specified on figure 2.

3.3 Electrical performance characteristics. Unless otherwise specified herein, the electrical performance characteristics are as specified in table I and shall apply over the full ambient operating temperature range.

3.4 Electrical test requirements. The electrical test requirements shall be the subgroups specified in table II. The electrical tests for each subgroup are described in table I.

3.5 Marking. Marking shall be in accordance with MIL-PRF-38535, appendix A. The part shall be marked with the PIN listed in 1.2 herein. In addition, the manufacturer's PIN may also be marked. For packages where marking of the entire SMD PIN number is not feasible due to space limitations, the manufacturer has the option of not marking the "5962-" on the device.

3.5.1 Certification/compliance mark. A compliance indicator "C" shall be marked on all non-JAN devices built in compliance to MIL-PRF-38535, appendix A. The compliance indicator "C" shall be replaced with a "Q" or "QML" certification mark in accordance with MIL-PRF-38535 to identify when the QML flow option is used.

3.6 Certificate of compliance. A certificate of compliance shall be required from a manufacturer in order to be listed as an approved source of supply in MIL-HDBK-103 (see 6.6 herein). The certificate of compliance submitted to DLA Land and Maritime-VA prior to listing as an approved source of supply shall affirm that the manufacturer's product meets the requirements of MIL-PRF-38535, appendix A and the requirements herein.

3.7 Certificate of conformance. A certificate of conformance as required in MIL-PRF-38535, appendix A shall be provided with each lot of microcircuits delivered to this drawing.

3.8 Notification of change. Notification of change to DLA Land and Maritime-VA shall be required for any change that affects this drawing.

3.9 Verification and review. DLA Land and Maritime, DLA Land and Maritime's agent, and the acquiring activity retain the option to review the manufacturer's facility and applicable required documentation. Offshore documentation shall be made available onshore at the option of the reviewer.

STANDARD MICROCIRCUIT DRAWING DLA LAND AND MARITIME COLUMBUS, OHIO 43218-3990	SIZE A		5962-89503
		REVISION LEVEL L	SHEET 4

TABLE I. Electrical performance characteristics.

Test	Symbol	Conditions <u>1/</u> -55°C ≤ TA ≤ +125°C unless otherwise specified	Group A subgroups	Device type	Limits <u>2/</u>		Unit	
					Min	Max		
Power supply <u>3/</u>	IDD	VDD = 1.5 V	1,2,3	05		200	μA	
		VDD = 5.0 V		01		700		
				02		1.4	mA	
				03		300	μA	
				04		400		
				05		300		
		VDD = 12 V			05		400	
		VDD = 15 V		01		1000		
				02		2.0	mA	
				03		300	μA	
				04		600		
					05		600	
		VDD = 18 V			03		350	
					04		700	
Trigger voltage	VTR	VDD = 1.5 V	1,2,3	05	0.4	0.6	V	
		VDD = 5.0 V		01-04	1.26	2.06		
				05	1.30	2.00		
		VDD = 12.0 V			05	3.70	4.30	
		VDD = 15.0 V			01-04	4.05	5.50	
		VDD = 18.0 V			03-04	4.70	6.85	
Reset voltage level	VRESET		1	01	0.4	1.5	V	
			2,3		0.3	1.8		

See footnotes at end of table.

STANDARD MICROCIRCUIT DRAWING DLA LAND AND MARITIME COLUMBUS, OHIO 43218-3990	SIZE A		5962-89503
		REVISION LEVEL L	SHEET 5

TABLE I. Electrical performance characteristics – continued.

Test	Symbol	Conditions <u>1/</u> -55°C ≤ TA ≤ +125°C unless otherwise specified	Group A subgroups	Device type	Limits <u>2/</u>		Unit
					Min	Max	
Trigger current <u>3/</u>	ITR	VDD = 1.5 V, TA = +25°C, +125°C	1,2	05		±50	nA
		VDD = 5.0 V, TA = +25°C, +125°C		03-05		±50	
		VDD = 12.0 V, TA = +25°C, +125°C		05		±50	
		VDD = 15.0 V, TA = +25°C, +125°C		03,04		±100	
		VDD = 18.0 V, TA = +25°C, +125°C		03,04		±100	
Threshold voltage	VTH	VDD = 1.5 V	1,2,3	05	0.70	1.90	V
		VDD = 5.0 V		All	2.70	3.90	
		VDD = 12.0 V		05	7.30	8.70	
		VDD = 15 V		01-04	9.15	10.80	
		VDD = 18 V		03-04	10.90	13.15	
Threshold current <u>3/</u>	ITH	VDD = 1.5 V, TA = +25°C, +125°C	1,2	05		±50	nA
		VDD = 5.0 V, TA = +25°C, +125°C		03-05		±50	
		VDD = 12.0 V, TA = +25°C, +125°C		05		±50	
		VDD = 15.0 V, TA = +25°C, +125°C		03,04		±100	
		VDD = 18.0 V, TA = +25°C, +125°C		03,04		±100	

See footnotes at end of table.

**STANDARD
MICROCIRCUIT DRAWING**
DLA LAND AND MARITIME
COLUMBUS, OHIO 43218-3990

SIZE
A

REVISION LEVEL
L

5962-89503

SHEET **6**

TABLE I. Electrical performance characteristics – continued.

Test	Symbol	Conditions <u>1/</u> -55°C ≤ TA ≤ +125°C unless otherwise specified	Group A subgroups	Device type	Limits <u>2/</u>		Unit
					Min	Max	
High level output voltage	VOH	VDD = 5.0 V, IOH = -1 mA	1,2,3	01,02	4.10		V
		VDD = 15.0 V, IOH = -10 mA			12.50		
		VDD = 15.0 V, IOH = -5 mA			13.50		
		VDD = 15.0 V, IOH = -1 mA			14.20		
		VDD = 5.0 V, IOH = -0.8 mA	03,04	3.80			
		VDD = 15.0 V, IOH = -0.8 mA		14.20			
		VDD = 18.0 V, IOH = -0.8 mA		17.30			
		VDD = 1.5 V, IOH = -0.25 mA	05	1.00	1.50		
		VDD = 5.0 V, IOH = -1.0 mA		4.20	5.00		
		VDD = 12.0 V, IOH = -10 mA		10.25	12.00		
		VDD = 12.0 V, IOH = -5 mA		10.70	12.00		
		VDD = 12.0 V, IOH = -1 mA		11.0	12.0		
		Monostable timing accuracy	tMON	5.0 V ≤ VDD ≤ 15 V, RT = 10 kΩ, CT = 0.1 μF, see figures 3 and 5	9	03,04	
	10,11			858	1161		
1.5 V ≤ VDD ≤ 12 V, RT = 10 kΩ, CT = 0.1 μF, see figures 3 and 5	9,10,11			05	900	1250	

See footnotes at end of table.

**STANDARD
MICROCIRCUIT DRAWING**
DLA LAND AND MARITIME
COLUMBUS, OHIO 43218-3990

SIZE
A

5962-89503

REVISION LEVEL
L

SHEET **7**

TABLE I. Electrical performance characteristics – continued.

Test	Symbol	Conditions <u>1/</u> -55°C ≤ TA ≤ +125°C unless otherwise specified	Group A subgroups	Device type	Limits <u>2/</u>		Unit
					Min	Max	
Low level output voltage	VOL	VDD = 5.0 V, IOL = 8.0 mA	1,2,3	01,02, 05		0.60	V
		VDD = 5.0 V, IOL = 5.0 mA				0.45	
		VDD = 5.0 V, IOL = 3.2 mA				0.40	
		VDD = 15.0 V, IOL = 100 mA		01,02		3.80	
		VDD = 15.0 V, IOL = 50 mA				1.50	
		VDD = 15.0 V, IOL = 10 mA				0.45	
		VDD = 5.0 V, IOL = 3.2 mA		03,04		0.50	
		VDD = 15.0 V, IOL = 20.0 mA				1.25	
		VDD = 18.0 V, IOL = 3.2 mA				0.50	
		VDD = 1.5 V, IOL = 1.0 mA		05		0.40	
		VDD = 12.0 V, IOL = 75 mA				3.50	
		VDD = 12.0 V, IOL = 50 mA				2.25	
		VDD = 12.0 V, IOL = 10 mA				1.00	
		Astable timing accuracy		tAST	5.0 V ≤ VDD ≤ 15 V, RTA = 10 kΩ, RTB = 10 kΩ, CT = 0.1 μF, see figures 4 and 6	9	
10,11	1717		2323				
VDD = 12 V, RTA = 1 kΩ, RTB = 1 kΩ, CT = 0.1 μF, see figures 4 and 6	9,10,11		05		178	250	
Discharge transistor leakage current	ICEX	VDD = 5.0 V, TA = +25°C, +125°C	1,2	03,04		300	nA
		VDD = 15.0 V, TA = +25°C, +125°C				300	
		VDD = 18.0 V, TA = +25°C, +125°C				300	

See footnotes at end of table.

STANDARD MICROCIRCUIT DRAWING DLA LAND AND MARITIME COLUMBUS, OHIO 43218-3990	SIZE A		5962-89503
		REVISION LEVEL L	SHEET 8

TABLE I. Electrical performance characteristics – continued.

Test	Symbol	Conditions <u>1/</u> -55°C ≤ TA ≤ +125°C unless otherwise specified	Group A subgroups	Device type	Limits <u>2/</u>		Unit
					Min	Max	
Discharge transistor leakage current	ICEX	VDD = 1.5 V, TA = +25°C, +125°C	1	05		100	nA
			2			1000	
		VDD = 5.0 V, TA = +25°C, +125°C	1			100	
			2			1000	
		VDD = 12.0 V, TA = +25°C, +125°C	1			100	
			2			1000	
Reset current <u>3/</u>	IR	VDD = 5.0 V, TA = +25°C, +125°C	1,2	All		±50	nA
		VDD = 15.0 V, TA = +25°C, +125°C		01-04		±100	
		VDD = 18.0 V, TA = +25°C, +125°C		03-04		±100	
		VDD = 1.5 V and 5.0 V, TA = +25°C, +125°C		05		±50	
		VDD = 12.0 V, TA = +25°C, +125°C				±50	
Discharge transistor saturation voltage	VSAT	VDD = 5.0 V, IOL = 10 mA	1,2,3	01,02		0.60	V
		VDD = 15.0 V, IOL = 100 mA				1.80	
		VDD = 5.0 V, IOL = 10 mA		03,04		0.60	
		VDD = 15.0 V, IOL = 10 mA				0.60	
		VDD = 18.0 V, IOL = 10 mA				0.60	
		VDD = 1.5 V, IOL = 1.0 mA		05		150	mV
		VDD = 5.0 V, IOL = 10 mA				0.30	V
		VDD = 12.0 V, IOL = 25 mA				2.00	

1/ Each side of device types 02 and 04 are tested separately.

2/ The limiting terms "min" (minimum) and "max" (maximum) shall be considered to apply to magnitudes only.
Negative current shall be defined as conventional current flow out of a device terminal.

3/ $1/3 V_{DD} \leq V_{IN} \leq 2/3 V_{DD}$.

**STANDARD
MICROCIRCUIT DRAWING**

DLA LAND AND MARITIME
COLUMBUS, OHIO 43218-3990

SIZE
A

REVISION LEVEL
L

5962-89503

SHEET **9**

Device types	01	01	02 and 04 see note 1	02	03 and 05
Case outlines	P	2	C	2	G and P see note 2
Terminal number	Terminal symbol				
1	GND	NC	DSCH1	NC	GND
2	$\overline{\text{TRIG}}$	GND	THRES1	DSCH1	$\overline{\text{TRIG}}$
3	OUT	NC	CONT1	THRES1	OUT
4	$\overline{\text{RESET}}$	NC	$\overline{\text{RESET1}}$	CONT1	$\overline{\text{RESET}}$
5	CONT	$\overline{\text{TRIG}}$	OUT1	NC	CONT
6	THRES	NC	$\overline{\text{TRIG1}}$	$\overline{\text{RESET1}}$	THRES
7	DSCH	OUT	GND	NC	DSCH
8	VDD	NC	$\overline{\text{TRIG2}}$	OUT1	VDD
9	---	NC	OUT2	$\overline{\text{TRIG1}}$	---
10	---	$\overline{\text{RESET}}$	$\overline{\text{RESET2}}$	GND	---
11	---	NC	CONT2	NC	---
12	---	CONT	THRES2	$\overline{\text{TRIG2}}$	---
13	---	NC	DSCH2	OUT2	---
14	---	NC	VDD	$\overline{\text{RESET2}}$	---
15	---	THRES	---	NC	---
16	---	NC	---	CONT2	---
17	---	DSCH	---	NC	---
18	---	NC	---	THRES2	---
19	---	NC	---	DSCH2	---
20	---	VDD	---	VDD	---

NOTES:

1. VDD and GND are common to both sides.
2. VDD and case are connected.

FIGURE 1. Terminal connections.

**STANDARD
MICROCIRCUIT DRAWING**

DLA LAND AND MARITIME
COLUMBUS, OHIO 43218-3990

SIZE
A

REVISION LEVEL
L

5962-89503

SHEET **10**

Device types 01 - 05

Threshold voltage	Trigger voltage	$\overline{\text{RESET}}$	Output	Discharge switch
Don't care	Don't care	Low	Low	On
$> 2/3 (V_{DD})$	$> 1/3 (V_{DD})$	High	Low	On
$< 2/3 (V_{DD})$	$> 1/3 (V_{DD})$	High	Stable	Stable
Don't care	$< 1/3 (V_{DD})$	High	High	Off

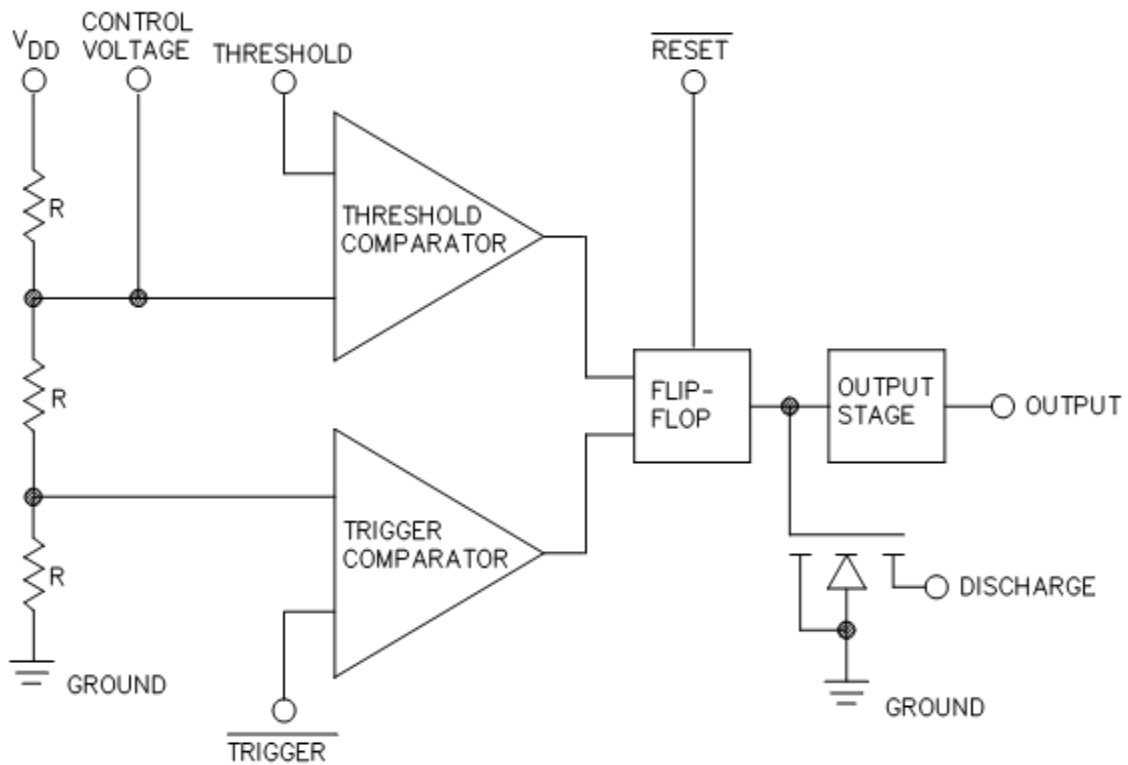

NOTE: 1 of 2 device types 02 and 04.

FIGURE 2. Block diagram and circuit operation table.

**STANDARD
MICROCIRCUIT DRAWING**

DLA LAND AND MARITIME
COLUMBUS, OHIO 43218-3990

SIZE
A

REVISION LEVEL
L

5962-89503

SHEET **11**

Device types 03, 04, and 05

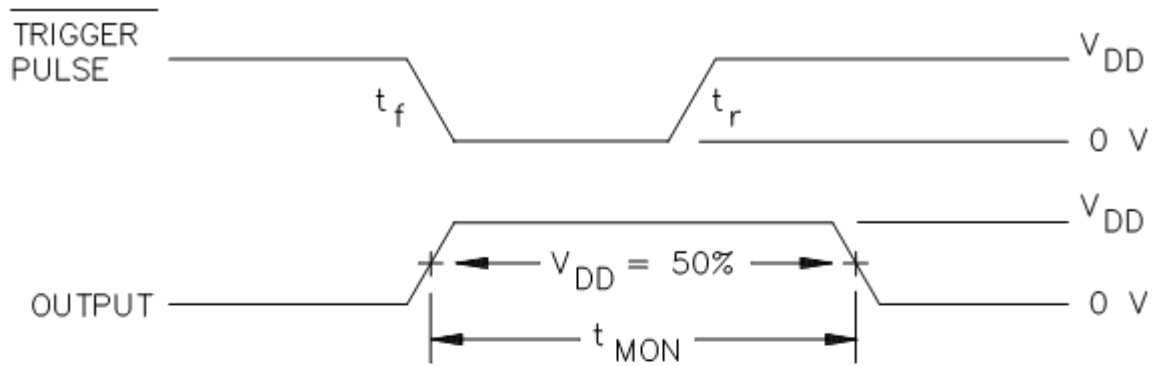

NOTE: $t_r = t_f \leq 10\text{ ns}$

FIGURE 3. Timing parameter (monostable).

Device types 03, 04, and 05

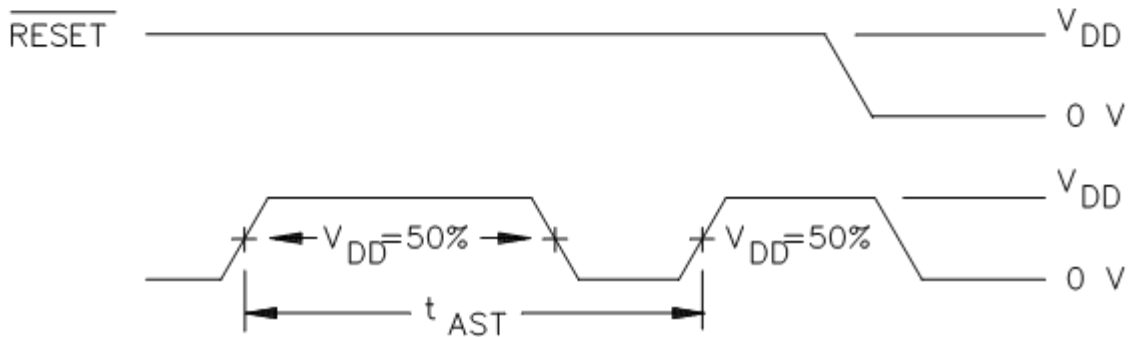

FIGURE 4. Timing parameter (astable).

**STANDARD
MICROCIRCUIT DRAWING**
DLA LAND AND MARITIME
COLUMBUS, OHIO 43218-3990

SIZE
A

5962-89503

REVISION LEVEL
L

SHEET **12**

Device types 03, 04, and 05

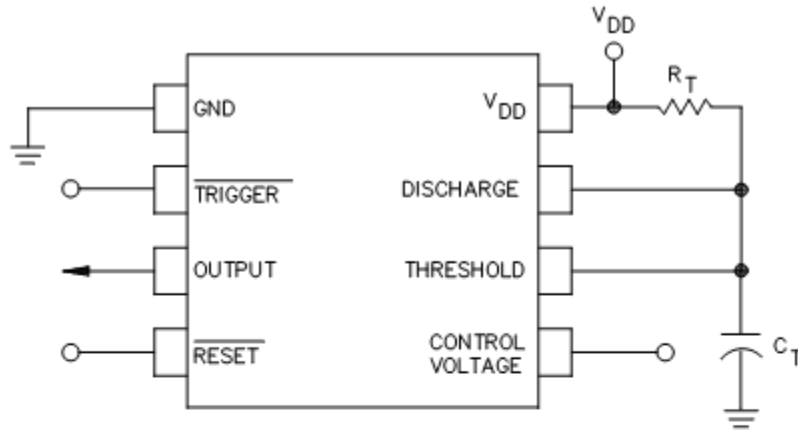

FIGURE 5. Monostable operation.

Device types 03, 04, and 05

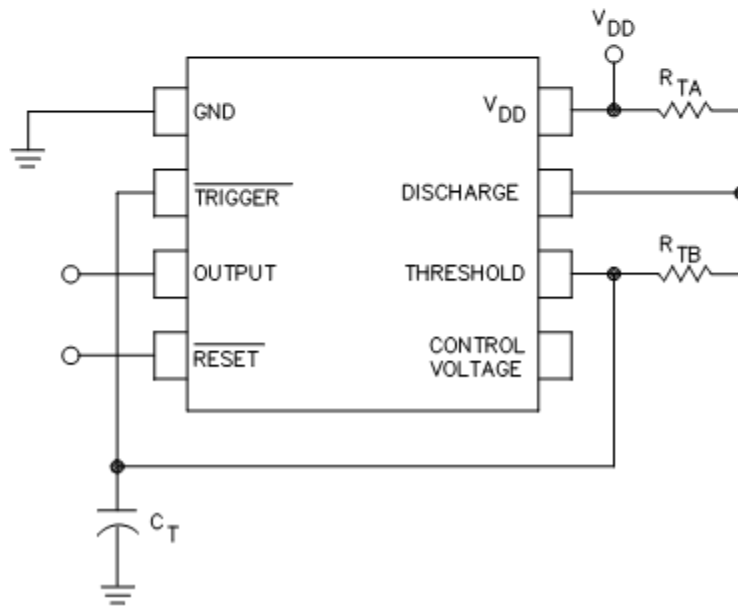

FIGURE 6. Astable operation.

**STANDARD
MICROCIRCUIT DRAWING**
DLA LAND AND MARITIME
COLUMBUS, OHIO 43218-3990

SIZE
A

5962-89503

REVISION LEVEL
L

SHEET **13**

4. VERIFICATION

4.1 Sampling and inspection. Sampling and inspection procedures shall be in accordance with MIL-PRF-38535, appendix A.

4.2 Screening. Screening shall be in accordance with method 5004 of MIL-STD-883, and shall be conducted on all devices prior to quality conformance inspection. The following additional criteria shall apply:

- a. Burn-in test, method 1015 of MIL-STD-883.
 - (1) Test condition A, B, C, or D. The test circuit shall be maintained by the manufacturer under document revision level control and shall be made available to the preparing or acquiring activity upon request. The test circuit shall specify the inputs, outputs, biases, and power dissipation, as applicable, in accordance with the intent specified in method 1015 of MIL-STD-883.
 - (2) $T_A = +125^\circ\text{C}$, minimum.
- b. Interim and final electrical test parameters shall be as specified in table II herein, except interim electrical parameter tests prior to burn-in are optional at the discretion of the manufacturer.

4.3 Quality conformance inspection. Quality conformance inspection shall be in accordance with method 5005 of MIL-STD-883 including groups A, B, C, and D inspections. The following additional criteria shall apply.

4.3.1 Group A inspection.

- a. Tests shall be as specified in table II herein.
- b. Subgroups 4, 5, 6, 7, and 8 in table I, method 5005 of MIL-STD-883 shall be omitted.

4.3.2 Groups C and D inspections.

- a. End-point electrical parameters shall be as specified in table II herein.
- b. Steady-state life test conditions, method 1005 of MIL-STD-883.
 - (1) Test condition A, B, C, or D. The test circuit shall be maintained by the manufacturer under document revision level control and shall be made available to the preparing or acquiring activity upon request. The test circuit shall specify the inputs, outputs, biases, and power dissipation, as applicable, in accordance with the intent specified in method 1005 of MIL-STD-883.
 - (2) $T_A = +125^\circ\text{C}$, minimum.
 - (3) Test duration: 1,000 hours, except as permitted by method 1005 of MIL-STD-883.

STANDARD MICROCIRCUIT DRAWING DLA LAND AND MARITIME COLUMBUS, OHIO 43218-3990	SIZE A		5962-89503
		REVISION LEVEL L	SHEET 14

TABLE II. Electrical test requirements.

MIL-STD-883 test requirements	Subgroups (in accordance with MIL-STD-883, method 5005, table I)
Interim electrical parameters (method 5004)	---
Final electrical test parameters (method 5004)	1*,2,3,9
Group A test requirements (method 5005)	1,2,3,9,10,11
Groups C and D end-point electrical parameters (method 5005)	1

* PDA applies to subgroup 1.

5. PACKAGING

5.1 Packaging requirements. The requirements for packaging shall be in accordance with MIL-PRF-38535, appendix A.

6. NOTES

6.1 Intended use. Microcircuits conforming to this drawing are intended for use for Government microcircuit applications (original equipment), design applications, and logistics purposes.

6.2 Replaceability. Microcircuits covered by this drawing will replace the same generic device covered by a contractor-prepared specification or drawing.

6.3 Configuration control of SMD's. All proposed changes to existing SMD's will be coordinated with the users of record for the individual documents. This coordination will be accomplished using DD Form 1692, Engineering Change Proposal, or email communication.

6.4 Record of users. Military and industrial users shall inform DLA Land and Maritime when a system application requires configuration control and the applicable SMD to that system. DLA Land and Maritime will maintain a record of users and this list will be used for coordination and distribution of changes to the drawings. Users of drawings covering microelectronics devices (FSC 5962) should contact DLA Land and Maritime-VA, telephone (614) 692-8108.

6.5 Comments. Comments on this drawing should be directed to DLA Land and Maritime-VA, Columbus, Ohio 43218-3990, or telephone (614) 692-0591.

6.6 Approved sources of supply. Approved sources of supply are listed in MIL-HDBK-103 and QML-38535. The vendors listed in MIL-HDBK-103 and QML-38535 have agreed to this drawing and a certificate of compliance (see 3.6 herein) has been submitted to and accepted by DLA Land and Maritime-VA.

STANDARD MICROCIRCUIT DRAWING DLA LAND AND MARITIME COLUMBUS, OHIO 43218-3990	SIZE A		5962-89503
		REVISION LEVEL L	SHEET 15

STANDARD MICROCIRCUIT DRAWING BULLETIN

DATE: 23-01-23

Approved sources of supply for SMD 5962-89503 are listed below for immediate acquisition information only and shall be added to MIL-HDBK-103 and QML-38535 during the next revision. MIL-HDBK-103 and QML-38535 will be revised to include the addition or deletion of sources. The vendors listed below have agreed to this drawing and a certificate of compliance has been submitted to and accepted by DLA Land and Maritime-VA. This information bulletin is superseded by the next dated revision of MIL-HDBK-103 and QML-38535. DLA Land and Maritime maintains an online database of all current sources of supply at <https://landandmaritimeapps.dla.mil/programs/smcr/>.

Standard microcircuit drawing PIN <u>1/</u>	Vendor CAGE number	Vendor similar PIN <u>2/</u>
5962-8950301PA	01295	TLC555MJGB
5962-89503012A	01295	TLC555MFKB
5962-8950302CA	01295	TLC556MJB
5962-89503022A	01295	TLC556MFKB
5962-8950303GA	3V146	ICM7555MTV/883
5962-8950303GC	3V146	ICM7555MTV/883
	<u>3/</u>	ICM7555MTV/883B
5962-8950303PA	<u>3/</u>	HI-7555CM-02
5962-8950304CA	<u>3/</u>	ICM7556MJD/883B
5962-8950305CA	<u>3/</u>	LMC555H/883
5962-8950305GA	<u>3/</u>	LMC555H/883
5962-8950305PA	<u>3/</u>	LMC555J/883C

- 1/ The lead finish shown for each PIN representing a hermetic package is the most readily available from the manufacturer listed for that part. If the desired lead finish is not listed contact the vendor to determine its availability.
- 2/ Caution. Do not use this number for item acquisition. Items acquired to this number may not satisfy the performance requirements of this drawing.
- 3/ Not available from an approved source of supply.

Vendor CAGE
number

Vendor name
and address

01295

Texas Instruments, Inc.
Semiconductor Group
8505 Forest Lane
P.O. Box 660199
Dallas, TX 75243

3V146

Rochester Electronics, LLC
16 Malcolm Hoyt Drive
Newburyport, MA 01950

The information contained herein is disseminated for convenience only and the Government assumes no liability whatsoever for any inaccuracies in the information bulletin.