

REVISIONS

| LTR | DESCRIPTION | DATE (YR-MO-DA) | APPROVED |
|-----|---|-----------------|--------------------|
| A | Add case outline F. Editorial changes throughout. - drw | 99-02-26 | Raymond Monnin |
| B | Replaced reference to MIL-STD-973 with reference to MIL-PRF-38535. Drawing updated to reflect current requirements. - rrp | 04-04-08 | Raymond Monnin |
| C | Redrawn. Update paragraphs to MIL-PRF-38535 requirements. - drw | 16-03-04 | Charles F. Saffle |
| D | Update paragraphs to MIL-PRF-38535 requirements. - jch | 22-10-28 | James R. Eschmeyer |



THE ORIGINAL FIRST SHEET OF THIS DRAWING HAS BEEN REPLACED.

Revision Status of Sheets

| | | | | | | | | | | | | | | | | | | | | | | | | | |
|-------|---|---|---|---|---|---|---|---|----|--|--|--|--|--|--|--|--|--|--|--|--|--|--|--|--|
| REV | | | | | | | | | | | | | | | | | | | | | | | | | |
| SHEET | | | | | | | | | | | | | | | | | | | | | | | | | |
| REV | D | D | D | D | D | D | D | D | D | | | | | | | | | | | | | | | | |
| SHEET | 1 | 2 | 3 | 4 | 6 | 7 | 8 | 9 | 10 | | | | | | | | | | | | | | | | |

| | | | |
|---|-----------------------------------|-------------------|---|
| PMIC N/A | | | |
| STANDARD MICROCIRCUIT DRAWING THIS DRAWING IS AVAILABLE FOR USE BY ALL DEPARTMENTS AND AGENCIES OF THE DEPARTMENT OF DEFENSE | PREPARED BY Joseph A. Kerby | | DLA LAND AND MARITIME COLUMBUS, OHIO 43218-3990 https://www.dla.mil/LandandMaritime MICROCIRCUIT, LINEAR, DUAL, DIFFERENTIAL LINE RECEIVERS, MONOLITHIC SILICON |
| | CHECKED BY Charles E. Besore | | |
| | APPROVED BY Michael A. Frye | | |
| | DRAWING APPROVAL DATE 91-02-07 | | |
| AMSC N/A | REVISION LEVEL D | SIZE A | CAGE CODE 67268 |
| | | SHEET | 1 OF 10 |
| | | 5962-88745 | |

1. SCOPE

1.1 Scope. This drawing describes device requirements for MIL-STD-883 compliant, non-JAN class level B microcircuits in accordance with MIL-PRF-38535, appendix A.

1.2 Part or Identifying Number (PIN). The complete PIN is as shown in the following example:

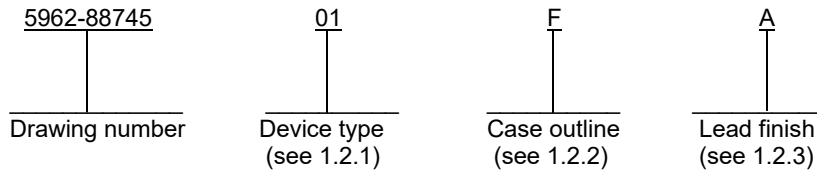

1.2.1 Device type(s). The device type(s) identify the circuit function as follows:

| <u>Device type</u> | <u>Generic number</u> | <u>Circuit function</u> |
|--------------------|-----------------------|----------------------------------|
| 01 | 55115 | Dual, differential line receiver |

1.2.2 Case outline(s). The case outline(s) are as designated in MIL-STD-1835 and as follows:

| <u>Outline letter</u> | <u>Descriptive designator</u> | <u>Terminals</u> | <u>Package style</u> |
|-----------------------|-------------------------------|------------------|------------------------------|
| 2 | CQCC1-N20 | 20 | Square leadless chip carrier |
| F | GDFP2-F16 | 16 | Flat pack |

1.2.3 Lead finish. The lead finish is as specified in MIL-PRF-38535, appendix A.

1.3 Absolute maximum ratings.

| | |
|--|-----------------------|
| Supply voltage (V_{CC}) | 7.0 V dc |
| Input voltage at A, B, and R_T inputs | ± 25 V dc |
| Input voltage at strobe input | 5.5 V dc |
| Off-state voltage applied to open collector inputs | 14 V dc |
| Power dissipation (P_D) | 1375 mW ^{1/} |
| Storage temperature range | -65°C to 150°C |
| Lead temperature (60 seconds) | 260°C |
| Thermal resistance, junction-to-case (θ_{JC}) | See MIL-STD-1835 |
| Thermal resistance, junction-to-ambient (θ_{JA}): | |
| Case outline 2 | 65°C/W |
| Case outline F | 165°C/W |

1.4 Recommended operating conditions.

| | |
|--|-----------------|
| Ambient operating temperature range | -55°C to +125°C |
| Supply voltage (V_{CC}) | 4.5 to 5.5 V dc |
| High level (strobe) input voltage (V_{IH}) | 2.4 V dc |
| Low level (strobe) input voltage (V_{IL}) | 0.4 V dc |
| High level output current (I_{OH}) | -5 mA |
| Low level output current (I_{OL}) | 15 mA |

^{1/} Must withstand the added P_D due to short circuit test; e.g., I_{OS} .

| | | | |
|--|------------------|----------------------------|-------------------|
| STANDARD MICROCIRCUIT DRAWING DLA LAND AND MARITIME COLUMBUS, OHIO 43218-3990 | SIZE A | | 5962-88745 |
| | | REVISION LEVEL D | SHEET 2 |

2. APPLICABLE DOCUMENTS

2.1 Government specification, standards, and handbooks. The following specification, standards, and handbooks form a part of this drawing to the extent specified herein. Unless otherwise specified, the issues of these documents are those cited in the solicitation or contract.

DEPARTMENT OF DEFENSE SPECIFICATION

MIL-PRF-38535 - Integrated Circuits, Manufacturing, General Specification for.

DEPARTMENT OF DEFENSE STANDARDS

MIL-STD-883 - Test Method Standard Microcircuits.
MIL-STD-1835 - Interface Standard Electronic Component Case Outlines.

DEPARTMENT OF DEFENSE HANDBOOKS

MIL-HDBK-103 - List of Standard Microcircuit Drawings.
MIL-HDBK-780 - Standard Microcircuit Drawings.

(Copies of these documents are available online at <https://quicksearch.dla.mil/>.)

2.2 Order of precedence. In the event of a conflict between the text of this drawing and the references cited herein, the text of this drawing takes precedence. Nothing in this document, however, supersedes applicable laws and regulations unless a specific exemption has been obtained.

3. REQUIREMENTS

3.1 Item requirements. The individual item requirements shall be in accordance with MIL-PRF-38535, appendix A for non-JAN class level B devices and as specified herein. Product built to this drawing that is produced by a Qualified Manufacturer Listing (QML) certified and qualified manufacturer or a manufacturer who has been granted transitional certification to MIL-PRF-38535 may be processed as QML product in accordance with the manufacturers approved program plan and qualifying activity approval in accordance with MIL-PRF-38535. This QML flow as documented in the Quality Management (QM) plan may make modifications to the requirements herein. These modifications shall not affect form, fit, or function of the device. These modifications shall not affect the PIN as described herein. A "Q" or "QML" certification mark in accordance with MIL-PRF-38535 is required to identify when the QML flow option is used.

3.2 Design, construction, and physical dimensions. The design, construction, and physical dimensions shall be as specified in MIL-PRF-38535, appendix A and herein.

3.2.1 Case outline(s). The case outline(s) shall be in accordance with 1.2.2 herein.

3.2.2 Terminal connections. The terminal connections shall be as specified on figure 1.

3.2.3 Truth table(s). The truth table(s) shall be as specified on figure 2.

3.3 Electrical performance characteristics. Unless otherwise specified herein, the electrical performance characteristics are as specified in table I and shall apply over the full ambient operating temperature range.

3.4 Electrical test requirements. The electrical test requirements shall be the subgroups specified in table II. The electrical tests for each subgroup are described in table I.

| | | | |
|--|------------------|----------------------------|-------------------|
| STANDARD MICROCIRCUIT DRAWING DLA LAND AND MARITIME COLUMBUS, OHIO 43218-3990 | SIZE A | | 5962-88745 |
| | | REVISION LEVEL D | SHEET 3 |

TABLE I. Electrical performance characteristics.

| Test | Symbol | Conditions 1/ -55°C ≤ T _A ≤ +125°C unless otherwise specified | Group A subgroups | Device type | Limits | | Unit |
|--|------------------|--|----------------------|----------------|---------------|------|------|
| | | | | | Min | Max | |
| Differential input high threshold voltage | V _{TH} | V _O = 0.4 V, I _{OL} = 15 mA, V _{IC} = 0 | 1, 2, 3 | 01 | | 500 | mV |
| Differential input low threshold voltage | V _{TL} | V _O = 2.4 V, I _{OH} = -5 mA, V _{IC} = 0 | 1, 2, 3 | 01 | -500 | | mV |
| High level output voltage | V _{OH} | V _{CC} = 4.5 V, I _{OH} = -5 mA, V _{ID} = -0.5 V | 3 | 01 | 2.2 | | V |
| | | | 1, 2 | | 2.4 | | |
| Low level output voltage | V _{OL} | V _{CC} = 4.5 V, I _{OL} = 15 mA, V _{ID} = 0.5 V | 1, 2, 3 | 01 | | 0.4 | V |
| Low level input current | I _{IL} | V _{CC} = 5.5 V, V _{ID} = 0.4 V Other input = 5.5 V | 3 | 01 | | -0.9 | mA |
| | | | 1, 2 | | -0.7 | | |
| High level strobe current | I _{SH} | V _{CC} = 4.5 V, V _{ID} = -0.5 V, V _{STROBE} = 4.5 V, T _A = +25°C, +125°C | 1 | 01 | | 2 | μA |
| | | | 2 | | 5 | | |
| Low level strobe current | I _{SL} | V _{CC} = 5.5 V, V _{ID} = 0.5 V, V _{STROBE} = 0.4 V, T _A = +25°C | 1 | 01 | | -2.4 | mA |
| Response time control current | I _{RTC} | V _{CC} = 5.5 V, V _{ID} = 0.5 V, V _{RC} = 0 V, T _A = +25°C | 1 | 01 | -1.2 | | mA |
| Off-state open collector output current | I _O | V _{CC} = 4.5 V, V _{ID} = -4.5 V, V _{OH} = 12 V, T _A = +25°C, +125°C | 1 | 01 | | 100 | μA |
| | | | 2 | | 200 | | |
| Line terminating resistance | R _T | V _{CC} = 5 V, T _A = +25°C | 1 | 01 | 77 | 176 | Ω |
| Common-mode input voltage | V _{ICM} | V _{ID} = ±1.0 V | 1, 2, 3 | 01 | +15 to -15 | | V |
| Short circuit output current <u>2/</u> | I _{OS} | V _{CC} = 5.5 V, V _{ID} = -0.5 V V _O = 0 V, T _A = +25°C | 1 | 01 | -15 | -80 | mA |

See footnotes at end of table.

| | | | |
|--|------------------|----------------------------|-------------------|
| STANDARD MICROCIRCUIT DRAWING DLA LAND AND MARITIME COLUMBUS, OHIO 43218-3990 | SIZE A | | 5962-88745 |
| | | REVISION LEVEL D | SHEET 4 |

TABLE I. Electrical performance characteristics – Continued.

| Test | Symbol | Conditions -55°C ≤ T _A ≤ +125°C unless otherwise specified | Group A subgroups | Device type | Limits | | Unit |
|--|------------------|--|----------------------|----------------|--------|-----|------|
| | | | | | Min | Max | |
| Functional test | | see 4.3.1c | 7, 8 | 01 | | | |
| Supply current (both receivers) | I _{CC} | V _{CC} = 5.5 V, V _{ID} = 0.5 V, V _{IC} = 0 V | 1, 2, 3 | 01 | | 50 | mA |
| Propagation delay time low-to-high level output | t _{PLH} | R _L = 3.9 kΩ, C _L = 30 pF, V _{CC} = 5.0 V, T _A = +25°C, see figure 3 | 9 | 01 | | 50 | ns |
| Propagation delay time low-to-high level output | t _{PHL} | R _L = 390Ω, C _L = 30 pF, V _{CC} = 5.0 V, T _A = +25°C, see figure 3 | 9 | 01 | | 50 | ns |

1/ V_{STROBE} = 2.4 V unless other wise specified. All parameters with the exception of off-state open collector output current (I_O), are measured with active pull-up connected to the sink output.

2/ Only one output shall be shorted at a time with duration not to exceed 1 second.

**STANDARD
MICROCIRCUIT DRAWING**
DLA LAND AND MARITIME
COLUMBUS, OHIO 43218-3990

SIZE
A

REVISION LEVEL
D

5962-88745

SHEET **5**

| Device type | 0 1 | |
|-----------------|-----------------|-----------------|
| Case outlines | 2 | F |
| Terminal number | Terminal symbol | |
| 1 | NC | 1YS |
| 2 | 1YS | 1YP |
| 3 | 1YP | 1STROBE |
| 4 | 1STROBE | 1RTC |
| 5 | 1RTC | 1B |
| 6 | NC | 1R _T |
| 7 | 1B | 1A |
| 8 | 1R _T | GND |
| 9 | 1A | 2A |
| 10 | GND | 2R _T |
| 11 | NC | 2B |
| 12 | 2A | 2RTC |
| 13 | 2R _T | 2STROBE |
| 14 | 2B | 2YP |
| 15 | 2RTC | 2YS |
| 16 | NC | V _{cc} |
| 17 | 2STROBE | ---- |
| 18 | 2YP | ---- |
| 19 | 2YS | ---- |
| 20 | V _{cc} | ---- |

FIGURE 1. Terminal connections.

| STROBE | DIFF INPUT | OUTPUT (YP and YS tied together) |
|--------|------------|-------------------------------------|
| L | X | H |
| H | L | H |
| H | H | L |

H = $V_I \geq V_{IH}$ min or V_{ID} more positive than V_{TH} max.
L = $V_I \leq V_{IL}$ max or V_{ID} more negative than V_{TL} max.
X = Irrelevant

FIGURE 2. Truth table.

| | | | |
|--|-------------------|-----------------------------|-------------------|
| STANDARD MICROCIRCUIT DRAWING DLA LAND AND MARITIME COLUMBUS, OHIO 43218-3990 | SIZE A | | 5962-88745 |
| | | REVISION LEVEL D | SHEET 6 |

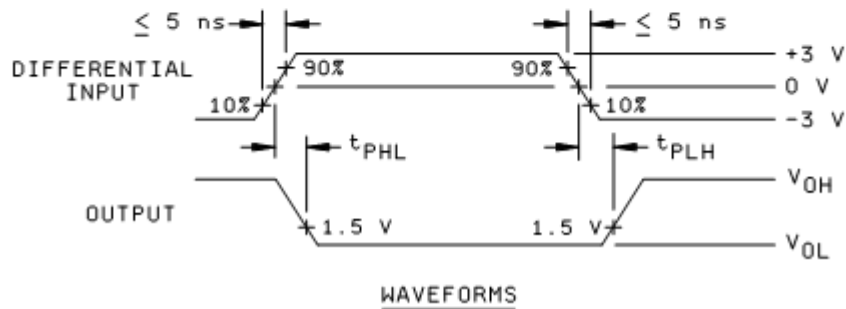
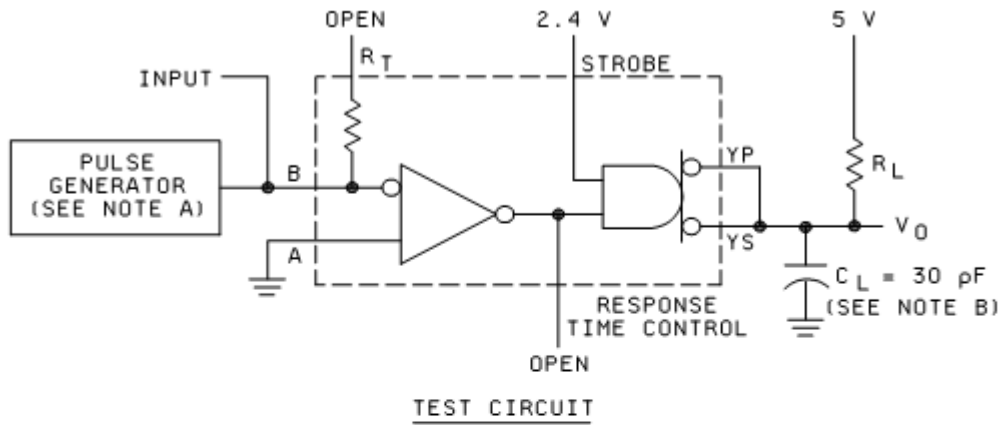

- NOTES: A. The pulse generator has the following characteristics: $Z_o = 50\Omega$, $PRR \leq 500\text{ kHz}$, $t_w = \leq 100\text{ ns}$, duty cycle = 50%.
 B. C_L includes probe and jig capacitance.

FIGURE 3. Delay waveforms and test circuit.

**STANDARD
MICROCIRCUIT DRAWING**
 DLA LAND AND MARITIME
 COLUMBUS, OHIO 43218-3990

SIZE
A

5962-88745

REVISION LEVEL
D

SHEET **7**

3.5 Marking. Marking shall be in accordance with MIL-PRF-38535, appendix A. The part shall be marked with the PIN listed in 1.2 herein. In addition, the manufacturer's PIN may also be marked. For packages where marking of the entire SMD PIN number is not feasible due to space limitations, the manufacturer has the option of not marking the "5962-" on the device.

3.5.1 Certification/compliance mark. A compliance indicator "C" shall be marked on all non-JAN devices built in compliance to MIL-PRF-38535, appendix A. The compliance indicator "C" shall be replaced with a "Q" or "QML" certification mark in accordance with MIL-PRF-38535 to identify when the QML flow option is used.

3.6 Certificate of compliance. A certificate of compliance shall be required from a manufacturer in order to be listed as an approved source of supply in MIL-HDBK-103 (see 6.6 herein). The certificate of compliance submitted to DLA Land and Maritime-VA prior to listing as an approved source of supply shall affirm that the manufacturer's product meets the requirements of MIL-PRF-38535, appendix A and the requirements herein.

3.7 Certificate of conformance. A certificate of conformance as required in MIL-PRF-38535, appendix A shall be provided with each lot of microcircuits delivered to this drawing.

3.8 Notification of change. Notification of change to DLA Land and Maritime-VA shall be required for any change that affects this drawing.

3.9 Verification and review. DLA Land and Maritime, DLA Land and Maritime's agent, and the acquiring activity retain the option to review the manufacturer's facility and applicable required documentation. Offshore documentation shall be made available onshore at the option of the reviewer.

4. VERIFICATION

4.1 Sampling and inspection. Sampling and inspection procedures shall be in accordance with MIL-PRF-38535, appendix A.

4.2 Screening. Screening shall be in accordance with method 5004 of MIL-STD-883, and shall be conducted on all devices prior to quality conformance inspection. The following additional criteria shall apply:

- a. Burn-in test, method 1015 of MIL-STD-883.
 - (1) Test condition A, B, C, or D. The test circuit shall be maintained by the manufacturer under document revision level control and shall be made available to the preparing or acquiring activity upon request. The test circuit shall specify the inputs, outputs, biases, and power dissipation, as applicable, in accordance with the intent specified in method 1015 of MIL-STD-883.
 - (2) $T_A = +125^{\circ}\text{C}$, minimum.
- b. Interim and final electrical test parameters shall be as specified in table II herein, except interim electrical parameter tests prior to burn-in are optional at the discretion of the manufacturer.

| | | | |
|--|------------------|----------------------------|-------------------|
| STANDARD MICROCIRCUIT DRAWING DLA LAND AND MARITIME COLUMBUS, OHIO 43218-3990 | SIZE A | | 5962-88745 |
| | | REVISION LEVEL D | SHEET 8 |

TABLE II. Electrical test requirements.

| MIL-STD-883 test requirements | Subgroups (in accordance with MIL-STD-883, method 5005, table I) |
|--|---|
| Interim electrical parameters (method 5004) | ---- |
| Final electrical test parameters (method 5004) | 1*, 2, 3, 9 |
| Group A test requirements (method 5005) | 1, 2, 3, 7, 8, 9 |
| Groups C and D end-point electrical parameters (method 5005) | 1, 2, 3 |

* PDA applies to subgroup 1.

4.3 Quality conformance inspection. Quality conformance inspection shall be in accordance with method 5005 of MIL-STD-883 including groups A, B, C, and D inspections. The following additional criteria shall apply.

4.3.1 Group A inspection.

- a. Tests shall be as specified in table II herein.
- b. Subgroups 4, 5, 6, 10 and 11 in table I, method 5005 of MIL-STD-883 shall be omitted.
- c. Subgroups 7 and 8 shall include verification of the truth table.

4.3.2 Groups C and D inspections.

- a. End-point electrical parameters shall be as specified in table II herein.
- b. Steady-state life test conditions, method 1005 of MIL-STD-883.
 - (1) Test condition A, B, C, or D. The test circuit shall be maintained by the manufacturer under document revision level control and shall be made available to the preparing or acquiring activity upon request. The test circuit shall specify the inputs, outputs, biases, and power dissipation, as applicable, in accordance with the intent specified in method 1005 of MIL-STD-883.
 - (2) $T_A = +125^{\circ}\text{C}$, minimum.
 - (3) Test duration: 1,000 hours, except as permitted by method 1005 of MIL-STD-883.

| | | | |
|--|------------------|----------------------------|-------------------|
| STANDARD MICROCIRCUIT DRAWING DLA LAND AND MARITIME COLUMBUS, OHIO 43218-3990 | SIZE A | | 5962-88745 |
| | | REVISION LEVEL D | SHEET 9 |

5. PACKAGING

5.1 Packaging requirements. The requirements for packaging shall be in accordance with MIL-PRF-38535, appendix A.

6. NOTES

6.1 Intended use. Microcircuits conforming to this drawing are intended for use for Government microcircuit applications (original equipment), design applications, and logistics purposes.

6.2 Replaceability. Microcircuits covered by this drawing will replace the same generic device covered by a contractor-prepared specification or drawing.

6.3 Configuration control of SMD's. All proposed changes to existing SMD's will be coordinated with the users of record for the individual documents. This coordination will be accomplished using DD Form 1692, Engineering Change Proposal, or email communication.

6.4 Record of users. Military and industrial users shall inform DLA Land and Maritime when a system application requires configuration control and the applicable SMD to that system. DLA Land and Maritime will maintain a record of users and this list will be used for coordination and distribution of changes to the drawings. Users of drawings covering microelectronics devices (FSC 5962) should contact DLA Land and Maritime-VA, telephone (614) 692-8108.

6.5 Comments. Comments on this drawing should be directed to DLA Land and Maritime-VA, Columbus, Ohio 43218-3990, or telephone (614) 692-0591.

6.6 Approved sources of supply. Approved sources of supply are listed in MIL-HDBK-103 and QML-38535. The vendors listed in MIL-HDBK-103 and QML-38535 have agreed to this drawing and a certificate of compliance (see 3.6 herein) has been submitted to and accepted by DLA Land and Maritime-VA.

| | | | |
|--|------------------|----------------------------|-------------------|
| STANDARD MICROCIRCUIT DRAWING DLA LAND AND MARITIME COLUMBUS, OHIO 43218-3990 | SIZE A | | 5962-88745 |
| | | REVISION LEVEL D | SHEET 10 |

STANDARD MICROCIRCUIT DRAWING BULLETIN

DATE: 22-10-28

Approved sources of supply for SMD 5962-88745 are listed below for immediate acquisition information only and shall be added to MIL-HDBK-103 and QML-38535 during the next revision. MIL-HDBK-103 and QML-38535 will be revised to include the addition or deletion of sources. The vendors listed below have agreed to this drawing and a certificate of compliance has been submitted to and accepted by DLA Land and Maritime-VA. This information bulletin is superseded by the next dated revision of MIL-HDBK-103 and QML-38535. DLA Land and Maritime maintains an online database of all current sources of supply at <https://landandmaritimeapps.dla.mil/programs/smcr/>.

| Standard microcircuit drawing PIN <u>1/</u> | Vendor CAGE number | Vendor similar PIN <u>2/</u> |
|---|--------------------|------------------------------|
| 5962-88745012A | 01295 | SNJ55115FK |
| 5962-8874501FA | 01295 | SNJ55115W |

- 1/ The lead finish shown for each PIN representing a hermetic package is the most readily available from the manufacturer listed for that part. If the desired lead finish is not listed contact the vendor to determine its availability.
- 2/ Caution. Do not use this number for item acquisition. Items acquired to this number may not satisfy the performance requirements of this drawing.

Vendor CAGE number

Vendor name and address

01295

Texas Instruments, Inc.
Semiconductor Group
8505 Forest Ln.
PO Box 660199
Dallas, TX 75243

The information contained herein is disseminated for convenience only and the Government assumes no liability whatsoever for any inaccuracies in the information bulletin.