

REVISIONS			
LTR	DESCRIPTION	DATE (YR-MO-DA)	APPROVED
A	Add device type 02. Add vendor CAGE 01295 for device type 02, cases E, F, and 2. Technical changes in 1.4 and table I. Change drawing CAGE code to 67268. Editorial changes throughout. mbk	89-08-10	M. A. Frye
B	Add vendor CAGE F8859. Add device class V criteria. Add table III, delta limits. Update boilerplate to MIL-PRF-38535 requirements. -jak	01-09-05	Thomas M. Hess
C	Add section 1.5, radiation features. Make changes I _{CCH} and I _{CCL} maximum limits for subgroup 1 in table I. Update the boilerplate to include radiation hardness assured requirements. Editorial changes throughout. - LTG	04-05-17	Charles F. Saffle
D	Correct descriptive designator for case outline X in paragraph 1.2.4. Update boilerplate to MIL-PRF-38535 requirements. Editorial changes throughout. - LTG	06-07-12	Thomas M. Hess
E	Update radiation hardened assurance paragraphs and tables. Update boilerplate to the current requirements of MIL-PRF-38535. Editorial changes throughout. - jak	12-12-03	Thomas M. Hess
F	Add case outline Y for device type 01. Update boilerplate paragraphs to the current MIL-PRF-38535 requirements. - LTG	18-11-21	Thomas M. Hess
G	Update boilerplate paragraphs to the current MIL-PRF-38535 requirements. - TM	20-03-02	Muhammad A. Akbar



REV																				
SHEET																				
REV	G																			
SHEET	15																			
REV STATUS	REV	G	G	G	G	G	G	G	G	G	G	G	G	G	G	G	G	G	G	G
OF SHEETS	SHEET	1	2	3	4	5	6	7	8	9	10	11	12	13	14					
PMIC N/A	PREPARED BY James E. Nicklaus	DLA LAND AND MARITIME COLUMBUS, OHIO 43218-3990 https://www.dla.mil/LandandMaritime																		
STANDARD MICROCIRCUIT DRAWING THIS DRAWING IS AVAILABLE FOR USE BY ALL DEPARTMENTS AND AGENCIES OF THE DEPARTMENT OF DEFENSE AMSC N/A	CHECKED BY D. A. DiCenzo	MICROCIRCUIT, DIGITAL, ADVANCED CMOS, TRIPLE THREE-INPUT AND GATE, MONOLITHIC SILICON																		
	APPROVED BY Nelson A. Hauck																			
	DRAWING APPROVAL DATE 87-05-21	SIZE A	CAGE CODE 67268	5962-87611																
	REVISION LEVEL G	SHEET 1 OF 15																		

1. SCOPE

1.1 Scope. This drawing documents two product assurance class levels consisting of high reliability (device class Q and M) and space application (device class V). A choice of case outlines and lead finishes are available and are reflected in the Part or Identifying Number (PIN). When available, a choice of Radiation Hardness Assurance (RHA) levels is reflected in the PIN.

1.2 PIN. The PIN is as shown in the following examples.

For device class M and Q:

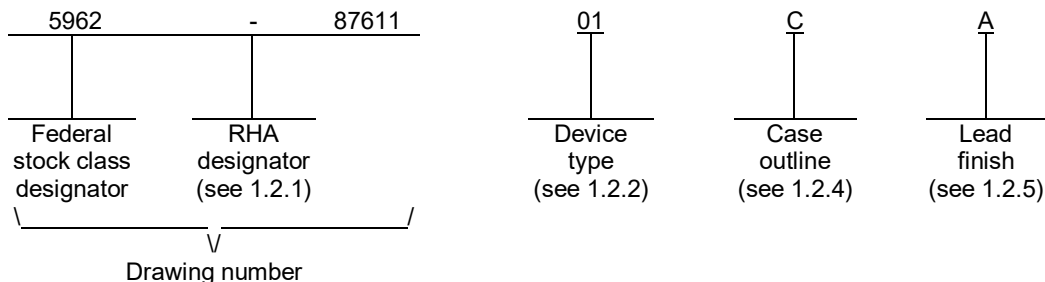

For device class V:

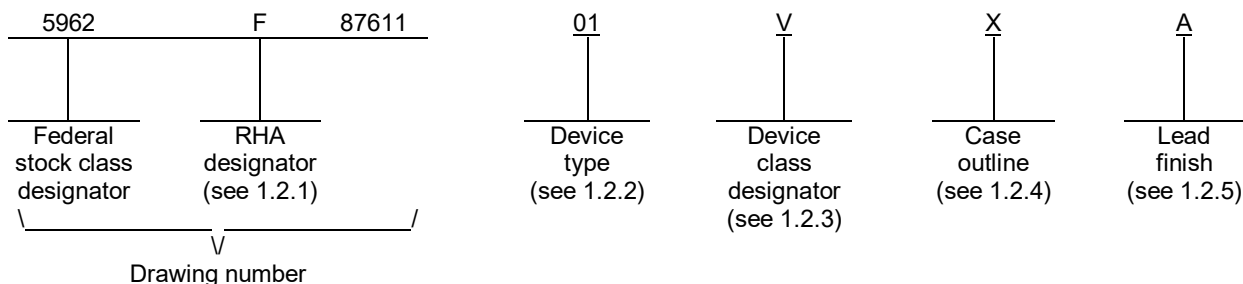

1.2.1 RHA designator. Device classes Q and V RHA marked devices meet the MIL-PRF-38535 specified RHA levels and are marked with the appropriate RHA designator. Device class M RHA marked devices meet the MIL-PRF-38535, appendix A specified RHA levels and are marked with the appropriate RHA designator. A dash (-) indicates a non-RHA device.

1.2.2 Device type(s). The device type(s) identify the circuit function as follows:

<u>Device type</u>	<u>Generic number</u>	<u>Circuit function</u>
01	54AC11	Triple three-input AND gate
02	54AC11011	Triple three-input AND gate

1.2.3 Device class designator. The device class designator is a single letter identifying the product assurance level as listed below. Since the device class designator has been added after the original issuance of this drawing, device classes M and Q designators will not be included in the PIN and will not be marked on the device.

<u>Device class</u>	<u>Device requirements documentation</u>
M	Vendor self-certification to the requirements for MIL-STD-883 compliant, non-JAN class level B microcircuits in accordance with MIL-PRF-38535, appendix A
Q or V	Certification and qualification to MIL-PRF-38535

STANDARD MICROCIRCUIT DRAWING DLA LAND AND MARITIME COLUMBUS, OHIO 43218-3990	SIZE A		5962-87611
		REVISION LEVEL G	SHEET 2

1.2.4 Case outline(s). The case outline(s) are as designated in MIL-STD-1835 and as follows:

<u>Outline letter</u>	<u>Descriptive designator</u>	<u>Terminals</u>	<u>Package style</u>
C	GDIP1-T14 or CDIP2-T14	14	Dual-in-line
D	GDFP1-F14 or CDFP2-F14	14	Flat pack
X	CDFP3-F14	14	Flat pack <u>6/</u>
Y	CDFP3-F14	14	Flat pack <u>7/</u>
E	GDIP1-T16 or CDIP2-T16	16	Dual-in-line
F	GDFP2-F16 or CDFP3-F16	16	Flat pack
2	CQCC1-N20	20	Square leadless chip carrier

1.2.5 Lead finish. The lead finish is as specified in MIL-PRF-38535 for device classes Q and V or MIL-PRF-38535, appendix A for device class M.

1.3 Absolute maximum ratings. 1/ 2/ 3/

Supply voltage range (V_{CC})	-0.5 V dc to +7.0 V dc
DC input voltage range (V_{IN})	-0.5 V dc to $V_{CC} + 0.5$ V dc
DC output voltage range (V_{OUT})	-0.5 V dc to $V_{CC} + 0.5$ V dc
Clamp diode current (I_{IK}, I_{OK})	± 20 mA
DC output current (per pin)	± 50 mA
DC V_{CC} or GND current (per pin)	± 100 mA
Storage temperature range (T_{STG})	-65°C to +150°C
Maximum power dissipation (P_D)	500 mW
Lead temperature (soldering, 10 seconds):	
Case outline X	+260°C
All other case outlines except X	+300°C
Thermal resistance, junction-to-case (θ_{JC})	See MIL-STD-1835
Junction temperature (T_J)	+175°C <u>4/</u>

1.4 Recommended operating conditions. 2/ 3/

Supply voltage range (V_{CC})	+2.0 V dc to +5.5 V dc <u>5/</u>
Input voltage range	0.0 V dc to V_{CC}
Output voltage range	0.0 V dc to V_{CC}
Case operating temperature range (T_C)	-55°C to +125°C
Input rise or fall time (t_r, t_f), $V_{CC} = 3.6$ V, $V_{CC} = 5.5$ V	0 to 8 ns

1.5 Radiation features.

Device type 01:

Maximum total dose (dose rate = 50 – 300 rads(Si)/s)	300 krad(Si)
No SEU occurs at effective LET (see 4.4.4.2)	≤ 93 MeV-cm ² /mg
No SEL occurs at effective LET (see 4.4.4.2)	≤ 93 MeV-cm ² /mg

- 1/ Stresses above the absolute maximum rating may cause permanent damage to the device. Extended operation at the maximum levels may degrade performance and affect reliability.
- 2/ Unless otherwise noted, all voltages are referenced to GND.
- 3/ The limits for the parameters specified herein shall apply over the full specified V_{CC} range and case temperature range of -55°C to +125°C.
- 4/ Maximum junction temperature shall not be exceeded except for allowable short duration burn-in screening conditions in accordance with method 5004 of MIL-STD-883.
- 5/ Operation from 2.0 V dc to 3.0 V dc is provided for compatibility with data retention and battery backup systems. Data retention implies no input transitions and no stored data loss with the following conditions: $V_{IH} \geq 70$ percent V_{CC} , $V_{IL} \leq 30$ percent V_{CC} , $V_{OH} \geq 70$ percent V_{CC} at -20 μ A, $V_{OL} \leq 30$ percent V_{CC} at 20 μ A.
- 6/ Package case outline X flat pack with isolated lid.
- 7/ Package case outline Y flat pack with grounded lid.

STANDARD MICROCIRCUIT DRAWING DLA LAND AND MARITIME COLUMBUS, OHIO 43218-3990	SIZE A		5962-87611
		REVISION LEVEL G	SHEET 3

2. APPLICABLE DOCUMENTS

2.1 Government specification, standards, and handbooks. The following specification, standards, and handbooks form a part of this drawing to the extent specified herein. Unless otherwise specified, the issues of these documents are those cited in the solicitation or contract.

DEPARTMENT OF DEFENSE SPECIFICATION

MIL-PRF-38535 - Integrated Circuits, Manufacturing, General Specification for.

DEPARTMENT OF DEFENSE STANDARDS

MIL-STD-883 - Test Method Standard Microcircuits.

MIL-STD-1835 - Interface Standard Electronic Component Case Outlines.

DEPARTMENT OF DEFENSE HANDBOOKS

MIL-HDBK-103 - List of Standard Microcircuit Drawings.

MIL-HDBK-780 - Standard Microcircuit Drawings.

(Copies of these documents are available online at <https://quicksearch.dla.mil/>.)

2.2 Non-Government publications. The following document(s) form a part of this document to the extent specified herein. Unless otherwise specified, the issues of these documents cited in the solicitation or contract.

JEDEC – SOLID STATE TECHNOLOGY ASSOCIATION (JEDEC)

JESD20 - Standard for Description of 54/74ACXXXXX and 54/74ACTXXXXX Advanced High-Speed CMOS Devices.

(Copies of these documents are available online at <https://www.jedec.org/>.)

ASTM INTERNATIONAL (ASTM)

ASTM F1192 - Standard Guide for the Measurement of Single Event Phenomena (SEP) Induced by Heavy Ion Irradiation of Semiconductor Devices.

(Copies of this document is available online at <https://www.astm.org/>.)

(Non-Government standards and other publications are normally available from the organizations that prepare or distribute the documents. These documents may also be available in or through libraries or other informational services.)

2.3 Order of precedence. In the event of a conflict between the text of this drawing and the references cited herein, the text of this drawing takes precedence. Nothing in this document, however, supersedes applicable laws and regulations unless a specific exemption has been obtained.

3. REQUIREMENTS

3.1 Item requirements. The individual item requirements for device classes Q and V shall be in accordance with MIL-PRF-38535 and as specified herein or as modified in the device manufacturer's Quality Management (QM) plan. The modification in the QM plan shall not affect the form, fit, or function as described herein.

3.2 Design, construction, and physical dimensions. The design, construction, and physical dimensions shall be as specified in MIL-PRF-38535 and herein for device classes Q and V.

3.2.1 Case outlines. The case outlines shall be in accordance with 1.2.4 herein.

3.2.2 Terminal connections. The terminal connections shall be as specified on figure 1.

3.2.3 Truth table. The truth table shall be as specified on figure 2.

STANDARD MICROCIRCUIT DRAWING DLA LAND AND MARITIME COLUMBUS, OHIO 43218-3990	SIZE A		5962-87611
		REVISION LEVEL G	SHEET 4

3.2.4 Logic diagram. The logic diagram shall be as specified on figure 3.

3.2.5 Switching waveforms and test circuit. The switching waveforms and test circuit shall be as specified on figure 4.

3.2.6 Radiation exposure circuit. The radiation exposure circuit shall be maintained by the manufacturer under document revision level control and shall be made available to the preparing and acquiring activity upon request.

3.3 Electrical performance characteristics and postirradiation parameter limits. Unless otherwise specified herein, the electrical performance characteristics and postirradiation parameter limits are as specified in table IA and shall apply over the full case operating temperature range.

3.4 Electrical test requirements. The electrical test requirements shall be the subgroups specified in table IIA. The electrical tests for each subgroup are defined in table IA.

3.5 Marking. The part shall be marked with the PIN listed in 1.2 herein. In addition, the manufacturer's PIN may also be marked. For packages where marking of the entire SMD PIN number is not feasible due to space limitations, the manufacturer has the option of not marking the "5962-" on the device. For RHA product using this option, the RHA designator shall still be marked. Marking for device classes Q and V shall be in accordance with MIL-PRF-38535. Marking for device class M shall be in accordance with MIL-PRF-38535, appendix A.

3.5.1 Certification/compliance mark. The certification mark for device classes Q and V shall be a "QML" or "Q" as required in MIL-PRF-38535. The compliance mark for device class M shall be a "C" as required in MIL-PRF-38535, appendix A.

3.6 Certificate of compliance. For device classes Q and V, a certificate of compliance shall be required from a QML-38535 listed manufacturer in order to supply to the requirements of this drawing (see 6.6.1 herein). For device class M, a certificate of compliance shall be required from a manufacturer in order to be listed as an approved source of supply in MIL-HDBK-103 (see 6.6.2 herein). The certificate of compliance submitted to DLA Land and Maritime-VA prior to listing as an approved source of supply for this drawing shall affirm that the manufacturer's product meets, for device classes Q and V, the requirements of MIL-PRF-38535 and herein or for device class M, the requirements of MIL-PRF-38535, appendix A and herein.

3.7 Certificate of conformance. A certificate of conformance as required for device classes Q and V in MIL-PRF-38535 or for device class M in MIL-PRF-38535, appendix A shall be provided with each lot of microcircuits delivered to this drawing.

3.8 Notification of change for device class M. For device class M, notification to DLA Land and Maritime-VA of change of product (see 6.2 herein) involving devices acquired to this drawing is required for any change that affects this drawing.

3.9 Verification and review for device class M. For device class M, DLA Land and Maritime, DLA Land and Maritime's agent, and the acquiring activity retain the option to review the manufacturer's facility and applicable required documentation. Offshore documentation shall be made available onshore at the option of the reviewer.

3.10 Microcircuit group assignment for device class M. Device class M devices covered by this drawing shall be in microcircuit group number 36 (see MIL-PRF-38535, appendix A).

STANDARD MICROCIRCUIT DRAWING DLA LAND AND MARITIME COLUMBUS, OHIO 43218-3990	SIZE A		5962-87611
		REVISION LEVEL G	SHEET 5

TABLE IA. Electrical performance characteristics.

Test and MIL-STD-883 test method <u>1/</u>	Symbol	Test conditions <u>2/ 3/</u> -55°C ≤ T _C ≤ +125°C +3.0 V ≤ V _{CC} ≤ +5.5 V unless otherwise specified	Device type and device class	V _{CC}	Group A subgroups	Limits <u>4/</u>		Unit
						Min	Max	
Positive input clamp voltage 3022	V _{IC+}	For input under test, I _{IN} = 1.0 mA	All V	0.0 V	1	0.4	1.5	V
Negative input clamp voltage 3022	V _{IC-}	For input under test, I _{IN} = -1.0 mA	All V	Open	1	-0.4	-1.5	V
High level output voltage 3006	V _{OH} <u>5/</u>	V _{IN} = V _{IH} or V _{IL} I _{OH} = -50 μA	All All	3.0 V	1, 2, 3	2.90		V
			All All	4.5 V		4.40		
			All All	5.5 V		5.40		
		V _{IN} = V _{IH} or V _{IL} I _{OH} = -4 mA	All All	3.0 V		2.40		
			All All	4.5 V		3.70		
				5.5 V		4.70		
V _{IN} = V _{IH} or V _{IL} I _{OH} = -50 mA	All All	5.5 V	3.85					
Low level output voltage 3007	V _{OL} <u>5/</u>	V _{IN} = V _{IH} or V _{IL} I _{OL} = 50 μA	All All	3.0 V	1, 2, 3		0.10	V
			All All	4.5 V			0.10	
			All All	5.5 V			0.10	
		V _{IN} = V _{IH} or V _{IL} I _{OL} = 12 mA	All All	3.0 V			0.50	
			All All	4.5 V			0.50	
				All All		5.5 V		
V _{IN} = V _{IH} or V _{IL} I _{OL} = 50 mA	All All	5.5 V		1.65				
High level input Voltage	V _{IH} <u>6/</u>		All All	3.0 V	1, 2, 3	2.1		V
			All All	4.5 V	1, 2, 3	3.15		
			All All	5.5 V	1, 2, 3	3.85		

See footnotes at end of table.

STANDARD MICROCIRCUIT DRAWING DLA LAND AND MARITIME COLUMBUS, OHIO 43218-3990	SIZE A		5962-87611
		REVISION LEVEL G	SHEET 6

TABLE IA. Electrical performance characteristics - Continued.

Test and MIL-STD-883 test method <u>1/</u>	Symbol	Test conditions <u>2/ 3/</u> -55°C ≤ T _C ≤ +125°C +3.0 V ≤ V _{CC} ≤ +5.5 V unless otherwise specified	Device type and device class	V _{CC}	Group A subgroups	Limits <u>4/</u>		Unit
						Min	Max	
Low level input voltage	V _{IL} <u>6/</u>		All All	3.0 V	1, 2, 3		0.9	V
				4.5 V			1.35	
				5.5 V			1.65	
Input leakage current low 3009	I _{IL}	V _{IN} = 0.0 V	All All	5.5 V	1		-0.1	μA
					2, 3		-1.0	
Input leakage current high 3010	I _{IH}	V _{IN} = 5.5 V	All All	5.5 V	1		0.1	μA
					2, 3		1.0	
Quiescent supply current, output high 3005	I _{CCH}	V _{IN} = 5.5 V	All All	5.5 V	1		2	μA
					2, 3		80	
					M, D, P, L, R, F <u>7/</u>	01 Q, V	1	
Quiescent supply current, output low 3005	I _{CCL}	V _{IN} = 0.0 V	All All	5.5 V	1		2	μA
					2, 3		80	
					M, D, P, L, R, F <u>7/</u>	01 Q, V	1	
Input capacitance 3012	C _{IN}	See 4.4.1c T _C = +25°C	All All	GND	4		8.0	pF
Power dissipation capacitance	C _{PD} <u>8/</u>	See 4.4.1c T _C = +25°C, f = 1 MHz	All All	5.0 V	4		40	pF
Functional tests 3014	<u>9/</u>	See 4.4.1b V _{IN} = V _{IH} or V _{IL} Verify output V _{OUT}	All All	3.0 V	7, 8	L	H	
				5.5 V	7, 8	L	H	
Propagation delay time, mA, mB, or mC to mY 3003	t _{PHL} <u>10/</u>	C _L = 50 pF minimum R _L = 500Ω See figure 4	All All	3.0 V	9	1.0	8.5	ns
					10, 11	1.0	10.5	
	t _{PLH} <u>10/</u>		All All	4.5 V	9	1.0	7.0	ns
					10, 11	1.0	8.0	
	All All		3.0 V	9	1.0	9.5	ns	
				10, 11	1.0	11.0		
All All	4.5 V	9	1.0	8.0	ns			
		10, 11	1.0	8.5				

1/ For tests not listed in the referenced MIL-STD-883, [e.g. V_{IH}, V_{IL}], utilize the general test procedure under the conditions listed herein.

2/ Each input/output, as applicable, shall be tested at the specified temperature, for the specified limits, to the tests in table IA herein. Output terminals not designated shall be high level logic, low level logic, or open, except as follows:

- a. V_{IC} (pos) tests, the GND terminal can be open. T_C = +25°C.
- b. V_{IC} (neg) tests, the V_{CC} terminal shall be open. T_C = +25°C.
- c. All I_{CC} tests, the output terminal shall be open. When performing these tests, the current meter shall be placed in the circuit such that all current flows through the meter.

3/ RHA parts for device type 01 have been characterized through all levels M, D, P, L, R, and F of irradiation. However, this device is only tested at the 'F' level. Pre and post irradiation values are identical unless otherwise specified in table IA. When performing post irradiation electrical measurements for any RHA level for any device, T_A = +25°C

**STANDARD
MICROCIRCUIT DRAWING**
DLA LAND AND MARITIME
COLUMBUS, OHIO 43218-3990

SIZE
A

5962-87611

REVISION LEVEL
G

SHEET
7

TABLE IA. Electrical performance characteristics - Continued.

- 4/ For negative and positive voltage and current values, the sign designates the potential difference in reference to GND and the direction of current flow, respectively; and the absolute value of the magnitude, not the sign, is relative to the minimum and maximum limits, as applicable, listed herein. All devices shall meet or exceed the limits specified in table I, as applicable, at $3.0\text{ V} \leq V_{CC} \leq 3.6\text{ V}$ and $4.5\text{ V} \leq V_{CC} \leq 5.5\text{ V}$.
- 5/ The V_{OH} and V_{OL} tests shall be tested at $V_{CC} = 3.0\text{ V}$ and 4.5 V . The V_{OH} and V_{OL} tests are guaranteed, if not tested, for other values of V_{CC} . Limits shown apply to operation at $V_{CC} = 3.3\text{ V} \pm 0.3\text{ V}$ and $V_{CC} = 5.0\text{ V} \pm 0.5\text{ V}$. Tests with input current at $+50\text{ mA}$ or -50 mA are performed on only one input at a time with duration not to exceed 10 ms. Transmission driving tests may be performed using $V_{IN} = V_{CC}$ or GND. When $V_{IN} = V_{CC}$ or GND is used, the test is guaranteed for $V_{IN} = V_{IH}$ minimum and V_{IL} maximum. Values for subgroup 1 shall be guaranteed, if not tested, to the limits specified in table I herein.
- 6/ The V_{IH} and V_{IL} tests are not required if applied as forcing functions for V_{OH} and V_{OL} tests.
- 7/ The maximum limit for this parameter at 100 krads (Si) is $2\text{ }\mu\text{A}$.
- 8/ Power dissipation capacitance (C_{PD}) determines both the power consumption (P_D) and dynamic current consumption (I_S). Where:

$$P_D = (C_{PD} + C_L) (V_{CC} \times V_{CC})f + (I_{CC} \times V_{CC})$$

$$I_S = (C_{PD} + C_L) V_{CC}f + I_{CC}$$
 f is the frequency of the input signal and C_L is the external output load capacitance.
- 9/ Tests shall be performed in sequence, attributes data only. Functional tests shall include the truth table and other logic patterns used for fault detection. The test vectors used to verify the truth table shall, at a minimum, test all functions of each input and output. All possible input to output logic patterns per function shall be guaranteed, if not tested, to the truth table in figure 2 herein. Functional tests shall be performed in sequence as approved by the qualifying activity on qualified devices. For V_{OUT} measurements, $L \leq 0.3V_{CC}$ and $H \geq 0.7V_{CC}$.
- 10/ AC limits at $V_{CC} = 5.5\text{ V}$ are equal to the limits at $V_{CC} = 4.5\text{ V}$ and guaranteed by testing at $V_{CC} = 4.5\text{ V}$. AC limits at $V_{CC} = 3.6\text{ V}$ are equal to limits at $V_{CC} = 3.0\text{ V}$ and guaranteed by testing at $V_{CC} = 3.0\text{ V}$. Minimum ac limits for $V_{CC} = 5.5\text{ V}$ and $V_{CC} = 3.6\text{ V}$ are 1.0 ns and guaranteed by guardbanding the $V_{CC} = 4.5\text{ V}$ and $V_{CC} = 3.0\text{ V}$ minimum limits, respectively, to 1.5 ns. For propagation delay tests, all paths must be tested.

TABLE IB. SEP test limits. 1/ 2/

Device type	Effective LET no upsets [MeV/(mg/cm ²)]	Bias for latch-up test $V_{DD} = 5.5\text{ V}$ no latch-up LET = [MeV/(mg/cm ²)] 3/ 4/
01	LET ≤ 93	≤ 93

- 1/ For SEP test conditions, see 4.4.4.2 herein.
- 2/ Technology characterization and model verification supplemented by in-line data may be used in lieu of end-of-line testing. Test plan must be approved by TRB and qualifying activity.
- 3/ Tested for latch-up at worst case operating temperature, $T_A = +25^\circ\text{C} \pm 10^\circ\text{C}$
- 4/ Tested at worst case temperature, $T_A = +125^\circ\text{C} \pm 10^\circ\text{C}$ for latch-up.

STANDARD MICROCIRCUIT DRAWING DLA LAND AND MARITIME COLUMBUS, OHIO 43218-3990	SIZE A		5962-87611
		REVISION LEVEL G	SHEET 8

Device types	01		02	
Case outlines	C, D, X, and Y	2	E, F	2
Pin number	Terminal symbol			
1	1A	NC	1A	NC
2	1B	1A	1Y	V _{CC}
3	2A	1B	2Y	2A
4	2B	2A	GND	1C
5	2C	NC	GND	1B
6	2Y	2B	3Y	NC
7	GND	NC	3C	1A
8	3Y	2C	3B	1Y
9	3A	2Y	3A	2Y
10	3B	GND	2C	GND
11	3C	NC	2B	NC
12	1Y	3Y	V _{CC}	GND
13	1C	3A	V _{CC}	3Y
14	V _{CC}	3B	2A	3C
15	---	NC	1C	3B
16	---	3C	1B	NC
17	---	NC	---	3A
18	---	1Y	---	2C
19	---	1C	---	2B
20	---	V _{CC}	---	V _{CC}

NC = No internal connection

FIGURE 1. Terminal connections.

STANDARD MICROCIRCUIT DRAWING DLA LAND AND MARITIME COLUMBUS, OHIO 43218-3990	SIZE A		5962-87611
		REVISION LEVEL G	SHEET 9

Inputs			Outputs
mA	mB	mC	mY
L	L	L	L
H	L	L	L
L	H	L	L
H	H	L	L
L	L	H	L
H	L	H	L
L	H	H	L
H	H	H	H

H = High voltage level
L = Low voltage level

FIGURE 2. Truth table.

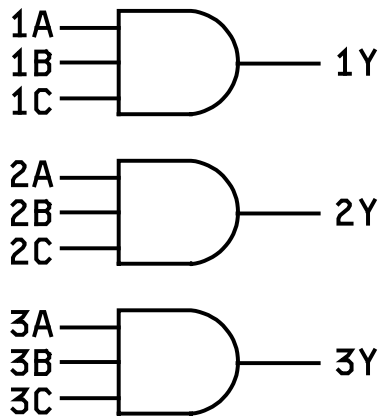
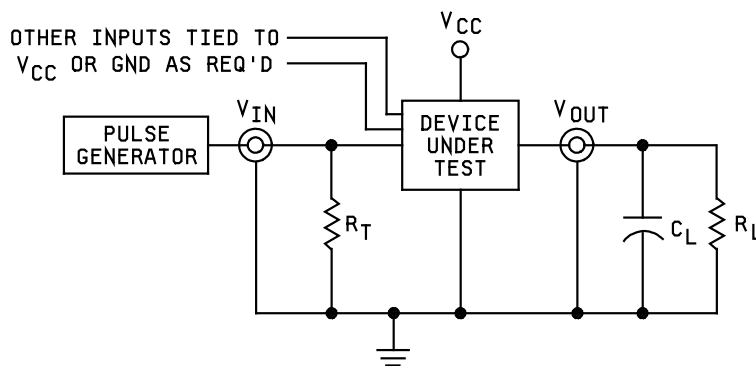
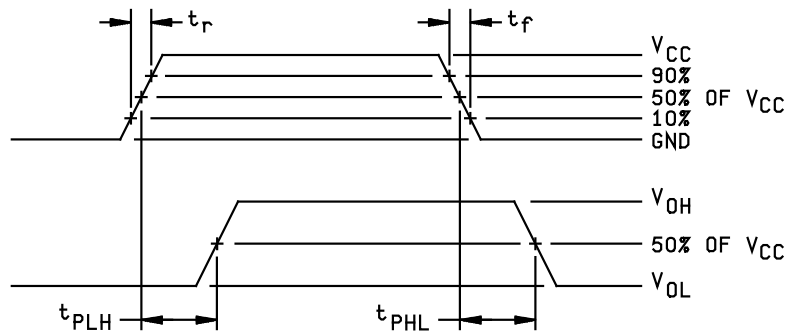

FIGURE 3. Logic diagram.

STANDARD MICROCIRCUIT DRAWING DLA LAND AND MARITIME COLUMBUS, OHIO 43218-3990	SIZE A		5962-87611
		REVISION LEVEL G	SHEET 10



1. $C_L = 50 \text{ pF}$ or equivalent, (includes probe and jig capacitance).
2. $R_L = 500\Omega$ or equivalent.
3. Input signal from pulse generator: $V_{IN} = 0.0 \text{ V to } V_{CC}$; $PRR \leq 1 \text{ MHz}$; $Z_O = 50\Omega$ $t_r \leq 3.0 \text{ ns}$; $t_f \leq 3.0 \text{ ns}$; t_r and t_f shall be measured from 10% of V_{CC} to 90% of V_{CC} and from 90% of V_{CC} to 10% of V_{CC} , respectively; duty cycle = 50 percent.
4. Timing parameters shall be tested at a minimum input frequency of 1MHz.
5. The outputs are measured one at a time with one transition per measurement.

FIGURE 4. Switching waveforms and test circuit.

STANDARD MICROCIRCUIT DRAWING DLA LAND AND MARITIME COLUMBUS, OHIO 43218-3990	SIZE A		5962-87611
		REVISION LEVEL G	SHEET 11

4. VERIFICATION

4.1 Sampling and inspection. For device classes Q and V, sampling and inspection procedures shall be in accordance with MIL-PRF-38535 or as modified in the device manufacturer's Quality Management (QM) plan. The modification in the QM plan shall not affect the form, fit, or function as described herein. For device class M, sampling and inspection procedures shall be in accordance with MIL-PRF-38535, appendix A.

4.2 Screening. For device classes Q and V, screening shall be in accordance with MIL-PRF-38535, and shall be conducted on all devices prior to qualification and technology conformance inspection. For device class M, screening shall be in accordance with method 5004 of MIL-STD-883, and shall be conducted on all devices prior to quality conformance inspection.

4.2.1 Additional criteria for device class M.

- a. Burn-in test, method 1015 of MIL-STD-883.
 - (1) Test condition A, B, C, or D. The test circuit shall be maintained by the manufacturer under document revision level control and shall be made available to the preparing or acquiring activity upon request. The test circuit shall specify the inputs, outputs, biases, and power dissipation, as applicable, in accordance with the intent specified in method 1015.
 - (2) $T_A = +125^\circ\text{C}$, minimum.
- b. Interim and final electrical test parameters shall be as specified in table IIA herein.

4.2.2 Additional criteria for device classes Q and V.

- a. The burn-in test duration, test condition and test temperature, or approved alternatives shall be as specified in the device manufacturer's QM plan in accordance with MIL-PRF-38535. The burn-in test circuit shall be maintained under document revision level control of the device manufacturer's Technology Review Board (TRB) in accordance with MIL-PRF-38535 and shall be made available to the acquiring or preparing activity upon request. The test circuit shall specify the inputs, outputs, biases, and power dissipation, as applicable, in accordance with the intent specified in method 1015 of MIL-STD-883.
- b. Interim and final electrical test parameters shall be as specified in table IIA herein.
- c. Additional screening for device class V beyond the requirements of device class Q shall be as specified in MIL-PRF-38535, appendix B.

4.3 Qualification inspection for device classes Q and V. Qualification inspection for device classes Q and V shall be in accordance with MIL-PRF-38535. Inspections to be performed shall be those specified in MIL-PRF-38535 and herein for groups A, B, C, D, and E inspections (see 4.4.1 through 4.4.4).

4.4 Conformance inspection. Technology conformance inspection for classes Q and V shall be in accordance with MIL-PRF-38535 including groups A, B, C, D, and E inspections and as specified. Quality conformance inspection for device class M shall be in accordance with MIL-PRF-38535, appendix A and as specified herein. Inspections to be performed for device class M shall be those specified in method 5005 of MIL-STD-883 and herein for groups A, B, C, D, and E inspections (see 4.4.1 through 4.4.4).

4.4.1 Group A inspection.

- a. Tests shall be as specified in table IIA herein.
- b. For device class M, subgroups 7 and 8 tests shall be sufficient to verify the truth table in figure 2 herein. The test vectors used to verify the truth table shall, at a minimum, test all functions of each input and output. All possible input to output logic patterns per function shall be guaranteed, if not tested, to the truth table in figure 2, herein. For device classes Q and V, subgroups 7 and 8 shall include verifying the functionality of the device.
- c. C_{IN} and C_{PD} shall be measured only for initial qualification and after process or design changes which may affect capacitance. C_{IN} shall be measured between the designated terminal and GND at a frequency of 1 MHz. C_{PD} shall be tested in accordance with the latest revision of JESD 20 and table I herein. For C_{IN} and C_{PD} , test all applicable pins on five devices with zero failures.

STANDARD MICROCIRCUIT DRAWING DLA LAND AND MARITIME COLUMBUS, OHIO 43218-3990	SIZE A		5962-87611
		REVISION LEVEL G	SHEET 12

TABLE IIA. Electrical test requirements.

Test requirements	Subgroups (in accordance with MIL-STD-883, method 5005, table I)	Subgroups (in accordance with MIL-PRF-38535, table III)	
	Device class M	Device class Q	Device class V
Interim electrical parameters (see 4.2)	---	---	1
Final electrical parameters (see 4.2)	<u>1/</u> 1, 2, 3, 7, 8, 9	<u>1/</u> 1, 2, 3, 7, 8, 9	<u>2/</u> <u>3/</u> 1, 2, 3, 7, 8, 9, 10, 11
Group A test requirements (see 4.4)	1, 2, 3, 4, 7, 8, 9, 10, 11	1, 2, 3, 4, 7, 8, 9, 10, 11	1, 2, 3, 4, 7, 8, 9, 10, 11
Group C end-point electrical parameters (see 4.4)	1, 2, 3	1, 2, 3	<u>3/</u> 1, 2, 3, 7, 8, 9, 10, 11
Group D end-point electrical parameters (see 4.4)	1, 2, 3	1, 2, 3	1, 2, 3, 7, 9
Group E end-point electrical parameters (see 4.4)	1, 7, 9	1, 7, 9	1, 7, 9

1/ PDA applies to subgroup 1.

2/ PDA applies to subgroups 1, 7, and deltas.

3/ Delta limits, as specified in table III, shall be required where specified and the delta limits shall be completed with reference to the zero hour electrical parameters.

TABLE IIB. Burn-in and operating life test, delta parameters (+25°C). 1/

Parameter <u>2/</u>	Symbol	Delta limits
Quiescent current	I _{CC}	±150 nA
Input current low level	I _{IL}	±20 nA
Input current high level	I _{IH}	±20 nA
Output voltage low level (I _{OL} = +24 mA, V _{CC} = 5.5 V)	V _{OL}	±0.04 V
Output voltage high level (I _{OH} = -24 mA, V _{CC} = 5.5 V)	V _{OH}	±0.20 V

1/ This table is representation of what vendor CAGE F8859 has experienced and is guaranteed and not meant to be construed as a quality assurance requirement for any other vendor.

2/ These parameters shall be recorded before and after the required burn-in and life tests to determine the delta limits.

4.4.2 Group C inspection. The group C inspection end-point electrical parameters shall be as specified in table IIA herein.

STANDARD MICROCIRCUIT DRAWING DLA LAND AND MARITIME COLUMBUS, OHIO 43218-3990	SIZE A		5962-87611
		REVISION LEVEL G	SHEET 13

4.4.2.1 Additional criteria for device class M. Steady-state life test conditions, method 1005 of MIL-STD-883:

- a. Test condition A, B, C, or D. The test circuit shall be maintained by the manufacturer under document revision level control and shall be made available to the preparing or acquiring activity upon request. The test circuit shall specify the inputs, outputs, biases, and power dissipation, as applicable, in accordance with the intent specified in method 1005 of MIL-STD-883.
- b. $T_A = +125^\circ\text{C}$, minimum.
- c. Test duration: 1,000 hours, except as permitted by method 1005 of MIL-STD-883.

4.4.2.2 Additional criteria for device classes Q and V. The steady-state life test duration, test condition and test temperature, or approved alternatives shall be as specified in the device manufacturer's QM plan in accordance with MIL-PRF-38535. The test circuit shall be maintained under document revision level control by the device manufacturer's TRB in accordance with MIL-PRF-38535 and shall be made available to the acquiring or preparing activity upon request. The test circuit shall specify the inputs, outputs, biases, and power dissipation, as applicable, in accordance with the intent specified in method 1005 of MIL-STD-883.

4.4.3 Group D inspection. The group D inspection end-point electrical parameters shall be as specified in table IIA herein.

4.4.4 Group E inspection. Group E inspection is required only for parts intended to be marked as radiation hardness assured (see 3.5 herein).

- a. End-point electrical parameters shall be as specified in table IIA herein.
- b. For device classes Q and V, the devices or test vehicle shall be subjected to radiation hardness assured tests as specified in MIL-PRF-38535 for the RHA level being tested. For device class M, the devices shall be subjected to radiation hardness assured tests as specified in MIL-PRF-38535, appendix A for the RHA level being tested. All device classes must meet the postirradiation end-point electrical parameter limits as defined in table IA at $T_A = +25^\circ\text{C} \pm 5^\circ\text{C}$, after exposure, to the subgroups specified in table IIA herein.

4.4.4.1 Total dose irradiation testing. Total dose irradiation testing shall be performed in accordance with MIL-STD-883, method 1019 condition A, and as specified herein.

Device type 01:

- a. Inputs tested high, $V_{CC} = 5.5 \text{ V dc} \pm 5\%$, $V_{IN} = 5.0 \text{ V dc} + 10\%$, $R_{IN} = 1 \text{ k}\Omega \pm 20\%$, and all outputs are open.
- b. Inputs tested low, $V_{CC} = 5.5 \text{ V dc} \pm 5\%$, $V_{IN} = 0.0 \text{ V dc}$, $R_{IN} = 1 \text{ k}\Omega \pm 20\%$, and all outputs are open.

4.4.4.1.1 Accelerated annealing testing. Accelerated annealing testing shall be performed on all devices requiring a RHA level greater than 5k rads (Si). The post-anneal end-point electrical parameter limits shall be as specified in table IA herein and shall be the pre-irradiation end-point electrical parameter limits at $25^\circ\text{C} \pm 5^\circ\text{C}$. Testing shall be performed at initial qualification and after any design or process changes which may affect the RHA response of the device.

4.4.4.2 Single event phenomena (SEP). When specified in the purchase order or contract, SEP testing shall be required on class V devices. SEP testing shall be performed on the Standard Evaluation Circuit (SEC) or alternate SEP test vehicle as approved by the qualifying activity at initial qualification and after any design or process changes which may affect the upset or latchup characteristics. Test four devices with zero failures. ASTM F1192 may be used as a guideline when performing SEP testing. The test conditions for SEP are as follows:

- a. The ion beam angle of incidence shall be between normal to the die surface and 60° to the normal, inclusive (i.e. $0^\circ \leq \text{angle} \leq 60^\circ$). No shadowing of the ion beam due to fixturing or package related effects is allowed.
- b. The fluence shall be ≥ 100 errors or $\geq 10^7$ ions/cm².
- c. The flux shall be between 10^2 and 10^5 ions/cm²/s. The cross-section shall be verified to be flux independent by measuring the cross-section at two flux rates which differ by at least an order of magnitude.
- d. The particle range shall be ≥ 20 micron in silicon.
- e. The test temperature shall be $+25^\circ\text{C}$ for the upset measurements and the maximum rated operating temperature $\pm 10^\circ\text{C}$ for the latch-up measurements.
- f. Bias conditions shall be defined by the manufacturer for the latch-up measurements.
- g. For SEP test limits, see table IB herein.

STANDARD MICROCIRCUIT DRAWING DLA LAND AND MARITIME COLUMBUS, OHIO 43218-3990	SIZE A		5962-87611
		REVISION LEVEL G	SHEET 14

4.5 Methods of inspection. Methods of inspection shall be specified as follows:

4.5.1 Voltage and current. Unless otherwise specified, all voltages given are referenced to the microcircuit GND terminal. Currents given are conventional current and positive when flowing into the referenced terminal.

5. PACKAGING

5.1 Packaging requirements. The requirements for packaging shall be in accordance with MIL-PRF-38535 for device classes Q and V or MIL-PRF-38535, appendix A for device class M.

6. NOTES

6.1 Intended use. Microcircuits conforming to this drawing are intended for use for Government microcircuit applications (original equipment), design applications, and logistics purposes.

6.1.1 Replaceability. Microcircuits covered by this drawing will replace the same generic device covered by a contractor-prepared specification or drawing.

6.2 Configuration control of SMD's. All proposed changes to existing SMD's will be coordinated with the users of record for the individual documents. This coordination will be accomplished using DD Form 1692, Engineering Change Proposal.

6.3 Record of users. Military and industrial users should inform DLA Land and Maritime when a system application requires configuration control and which SMD's are applicable to that system. DLA Land and Maritime will maintain a record of users and this list will be used for coordination and distribution of changes to the drawings. Users of drawings covering microelectronic devices (FSC 5962) should contact DLA Land and Maritime-VA, telephone (614) 692-8108.

6.4 Comments. Comments on this drawing should be directed to DLA Land and Maritime-VA, Columbus, Ohio 43218-3990, or telephone (614) 692-0540.

6.5 Abbreviations, symbols, and definitions. The abbreviations, symbols, and definitions used herein are defined in MIL-PRF-38535 and MIL-HDBK-1331.

6.6 Sources of supply.

6.6.1 Sources of supply for device classes Q and V. Sources of supply for device classes Q and V are listed in MIL-HDBK-103 and QML-38535. The vendors listed in MIL-HDBK-103 and QML-38535 have submitted a certificate of compliance (see 3.6 herein) to DLA Land and Maritime-VA and have agreed to this drawing.

6.6.2 Approved sources of supply for device class M. Approved sources of supply for class M are listed in MIL-HDBK-103. The vendors listed in MIL-HDBK-103 have agreed to this drawing and a certificate of compliance (see 3.6 herein) has been submitted to and accepted by DLA Land and Maritime-VA.

6.7 Additional information. When specified in the purchase order or contract, a copy of the following additional data shall be supplied.

- a. RHA test conditions (SEP).
- b. Number of upsets (SEU).
- c. Number of transients (SET)
- d. Occurrence of latch-up (SEL)

STANDARD MICROCIRCUIT DRAWING DLA LAND AND MARITIME COLUMBUS, OHIO 43218-3990	SIZE A		5962-87611
		REVISION LEVEL G	SHEET 15

STANDARD MICROCIRCUIT DRAWING BULLETIN

DATE: 20-03-02

Approved sources of supply for SMD 5962-87611 are listed below for immediate acquisition information only and shall be added to MIL-HDBK-103 and QML-38535 during the next revision. MIL-HDBK-103 and QML-38535 will be revised to include the addition or deletion of sources. The vendors listed below have agreed to this drawing and a certificate of compliance has been submitted to and accepted by DLA Land and Maritime-VA. This information bulletin is superseded by the next dated revision of MIL-HDBK-103 and QML-38535. DLA Land and Maritime maintains an online database of all current sources of supply at <https://landandmaritimeapps.dla.mil/programs/smcr/>.

Standard microcircuit drawing PIN <u>1/</u>	Vendor CAGE number	Vendor similar PIN <u>2/</u>
5962-87611012A	0C7V7	54AC11LMQB
	01295	SNJ54AC11FK
	3V146	54AC11/Q2A
5962-8761101CA	0C7V7	54AC11DMQB
	01295	SNJ54AC11J
	3V146	54AC11/QCA
5962-8761101DA	0C7V7	54AC11FMQB
	01295	SNJ54AC11W
	3V146	54AC11/QDA
5962F8761101CA	F8859	RHFAC11D04Q
5962F8761101CC	F8859	RHFAC11D03Q
5962F8761101VCA	F8859	RHFAC11D04V
5962F8761101VCC	F8859	RHFAC11D03V
5962F8761101VXA	F8859	RHFAC11K02V
5962F8761101VXC	F8859	RHFAC11K01V
5962F8761101VYC	F8859	RHFAC11K03V
5962F8761101VYA	F8859	RHFAC11K04V
5962-8761101VXA	<u>3/</u>	54AC11 (GEN)
5962-8761101XA	<u>3/</u>	54AC11K02Q
5962-8761101XC	<u>3/</u>	54AC11K01Q
5962-87611022A	3V146	54AC11011/B2A
5962-8761102EA	3V146	54AC11011/BEA
5962-8761102FA	3V146	54AC11011/BFA

1/ The lead finish shown for each PIN representing a hermetic package is the most readily available from the manufacturer listed for that part. If the desired lead finish is not listed, contact the vendor to determine its availability.

2/ Caution. Do not use this number for item acquisition. Items acquired to this number may not satisfy the performance requirements of this drawing.

3/ Not available from an approved source of supply.

STANDARD MICROCIRCUIT DRAWING BULLETIN – Continued.

DATE: 20-03-02

<u>Vendor CAGE number</u>	<u>Vendor name and address</u>
01295	Texas Instruments Semiconductor Group 8505 Forest Ln. P.O. Box 660199 Dallas TX 75243
0C7V7	Teledyne e2v, Inc. 765 Sycamore Drive Milpitas, CA 95035
3V146	Rochester Electronics Inc. 16 Malcolm Hoyt Drive Newburyport, MA 01950
F8859	ST Microelectronics 3 rue de Suisse CS 60816 35208 RENNES cedex2-FRANCE

The information contained herein is disseminated for convenience only and the Government assumes no liability whatsoever for any inaccuracies in the information bulletin.