

REVISIONS

LTR	DESCRIPTION	DATE (YR-MO-DA)	APPROVED
A	Add vendor CAGE F8859. Add device class V criteria. Add case outline X. Update boilerplate. Moved t_{rec} , t_s , t_w , t_h , and f_{MAX} from Para 1.4 to Table I. Changes to Table I include V_{OL} , V_{OH} , and others. Correct data limits in paragraph 1.3. Add Table III. Editorial changes throughout. -les	00-08-22	Raymond Monnin
B	Correct table II. Update boilerplate to MIL-PRF- 38535 requirements. - jak	02-01-25	Thomas M. Hess
C	Update boilerplate to MIL-PRF- 38535 requirements. - LTG	08-02-26	Thomas M. Hess
D	Update boilerplate paragraphs to MIL-PRF- 38535 requirements. - -jwc	14-04-25	Thomas M. Hess
E	Update boilerplate to MIL-PRF- 38535 requirements. - DRH	21-02-05	Muhammad A. Akbar



REV																			
SHEET																			
REV	E	E	E	E	E	E													
SHEET	15	16	17	18	19	20													
REV STATUS OF SHEETS	REV			E	E	E	E	E	E	E	E	E	E	E	E	E	E	E	E
	SHEET			1	2	3	4	5	6	7	8	9	10	11	12	13	14		

PMIC N/A	PREPARED BY Greg A. Pitz	<p align="center">DLA LAND AND MARITIME COLUMBUS, OHIO 43218-3990 https://www.dla.mil/LandandMaritime</p> <p align="center">MICROCIRCUIT, DIGITAL, HIGH-SPEED CMOS, 4-BIT SYNCHRONOUS UP/DOWN BINARY COUNTER, MONOLITHIC SILICON</p>																	
<p align="center">STANDARD MICROCIRCUIT DRAWING</p> <p>THIS DRAWING IS AVAILABLE FOR USE BY ALL DEPARTMENTS AND AGENCIES OF THE DEPARTMENT OF DEFENSE</p> <p align="center">AMSC N/A</p>	CHECKED BY D. A. DiCenzo																		
	APPROVED BY N. A. Hauck																		
	DRAWING APPROVAL DATE 87-06-05																		
	REVISION LEVEL E	SIZE A	CAGE CODE 67268	5962-86891															
SHEET 1 OF 20																			

1. SCOPE

1.1 Scope. This drawing documents two product assurance class levels consisting of high reliability (device classes Q and M) and space application (device class V). A choice of case outlines and lead finishes are available and are reflected in the Part or Identifying Number (PIN). When available, a choice of Radiation Hardness Assurance (RHA) levels is reflected in the PIN.

1.2 PIN. The PIN is as shown in the following examples.

For device classes M and Q:

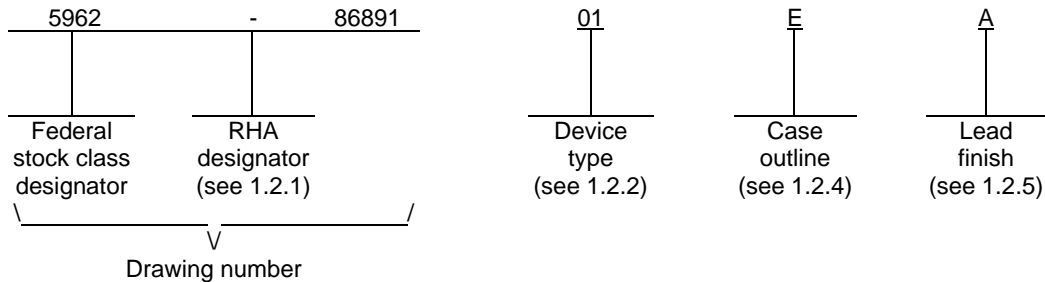

For device class V:

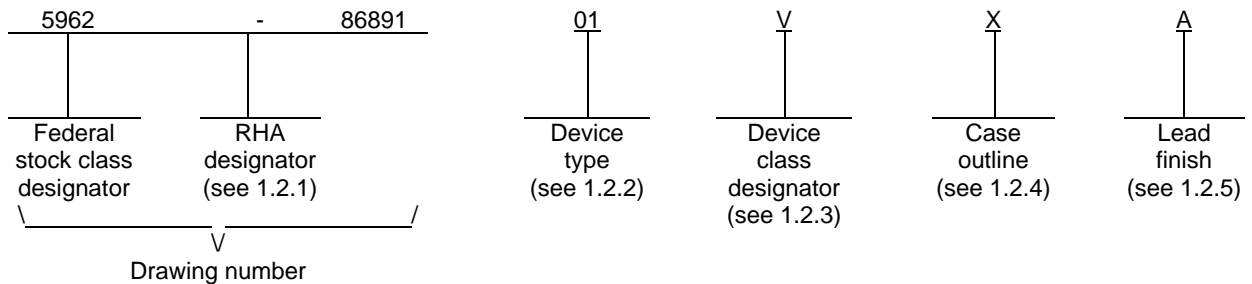

1.2.1 RHA designator. Device classes Q and V RHA marked devices meet the MIL-PRF-38535 specified RHA levels and are marked with the appropriate RHA designator. Device class M RHA marked devices meet the MIL-PRF-38535, appendix A specified RHA levels and are marked with the appropriate RHA designator. A dash (-) indicates a non-RHA device.

1.2.2 Device type(s). The device type(s) identify the circuit function as follows:

<u>Device type</u>	<u>Generic number</u>	<u>Circuit function</u>
01	54HC191	4-Bit synchronous up/down binary counter

1.2.3 Device class designator. The device class designator is a single letter identifying the product assurance level as listed below. Since the device class designator has been added after the original issuance of this drawing, device classes M and Q designators will not be included in the PIN and will not be marked on the device.

<u>Device class</u>	<u>Device requirements documentation</u>
M	Vendor self-certification to the requirements for MIL-STD-883 compliant, non-JAN class level B microcircuits in accordance with MIL-PRF-38535, appendix A
Q or V	Certification and qualification to MIL-PRF-38535

STANDARD MICROCIRCUIT DRAWING DLA LAND AND MARITIME COLUMBUS, OHIO 43218-3990	SIZE A		5962-86891
		REVISION LEVEL E	SHEET 2

1.2.4 Case outline(s). The case outline(s) are as designated in MIL-STD-1835 and as follows:

<u>Outline letter</u>	<u>Descriptive designator</u>	<u>Terminals</u>	<u>Package style</u>
E	GDIP1-T16 or CDIP2-T16	16	Dual-in-line
2	CQCC1-N20 or CQCC2-N20	20	Square leadless chip carrier
X	CDFP4-F16	16	Flat pack

1.2.5 Lead finish. The lead finish is as specified in MIL-PRF-38535 for device classes Q and V or MIL-PRF-38535, appendix A for device class M.

1.3 Absolute maximum ratings. 1/ 2/ 3/

Supply voltage range (V_{CC})	-0.5 V dc to +7.0 V dc
DC input voltage range (V_{IN})	-0.5 V dc to $V_{CC} + 0.5$ V dc
DC output voltage range (V_{OUT})	-0.5 V dc to $V_{CC} + 0.5$ V dc
Input clamp current (I_{IK})	± 20 mA
Output clamp current (I_{OK})	± 20 mA
Continuous output current	± 25 mA
Continuous current through V_{CC} or GND	± 50 mA
Storage temperature range (T_{STG})	-65°C to +150°C
Maximum power dissipation (P_D)	500 mW <u>4/</u>
Lead temperature (soldering, 10 seconds)	+260°C
Thermal resistance, junction-to-case (θ_{JC})	See MIL-STD-1835
Junction temperature (T_J)	+175°C <u>5/</u>

1.4 Recommended operating conditions. 2/ 3/

Supply voltage range (V_{CC})	+2.0 V dc to +6.0 V dc
Case operating temperature range (T_C)	-55°C to +125°C
Input rise or fall time (t_r , t_f):	
$V_{CC} = 2.0$ V	0 to 1000 ns
$V_{CC} = 4.5$ V	0 to 500 ns
$V_{CC} = 6.0$ V	0 to 400 ns

- 1/ Stresses above the absolute maximum rating may cause permanent damage to the device. Extended operation at the maximum levels may degrade performance and affect reliability.
- 2/ Unless otherwise specified, all voltages are referenced to GND.
- 3/ The limits for the parameters specified herein shall apply over the full specified V_{CC} range and case temperature range of -55°C to +125°C.
- 4/ For $T_C = +100^\circ\text{C}$ to +125°C, derate linearly at 12 mW/°C.
- 5/ Maximum junction temperature shall not be exceeded except for allowable short duration burn-in screening conditions in accordance with method 5004 of MIL-STD-883.

STANDARD MICROCIRCUIT DRAWING DLA LAND AND MARITIME COLUMBUS, OHIO 43218-3990	SIZE A		5962-86891
		REVISION LEVEL E	SHEET 3

2. APPLICABLE DOCUMENTS

2.1 Government specification, standards, and handbooks. The following specification, standards, and handbooks form a part of this drawing to the extent specified herein. Unless otherwise specified, the issues of these documents are those cited in the solicitation or contract.

DEPARTMENT OF DEFENSE SPECIFICATION

MIL-PRF-38535 - Integrated Circuits, Manufacturing, General Specification for.

DEPARTMENT OF DEFENSE STANDARDS

MIL-STD-883 - Test Method Standard Microcircuits.
MIL-STD-1835 - Interface Standard Electronic Component Case Outlines.

DEPARTMENT OF DEFENSE HANDBOOKS

MIL-HDBK-103 - List of Standard Microcircuit Drawings.
MIL-HDBK-780 - Standard Microcircuit Drawings.

(Copies of these documents are available online at <https://quicksearch.dla.mil/>).

2.2 Order of precedence. In the event of a conflict between the text of this drawing and the references cited herein, the text of this drawing takes precedence. Nothing in this document, however, supersedes applicable laws and regulations unless a specific exemption has been obtained.

3. REQUIREMENTS

3.1 Item requirements. The individual item requirements for device classes Q and V shall be in accordance with MIL-PRF-38535 and as specified herein or as modified in the device manufacturer's Quality Management (QM) plan. The modification in the QM plan shall not affect the form, fit, or function as described herein. The individual item requirements for device class M shall be in accordance with MIL-PRF-38535, appendix A for non-JAN class level B devices and as specified herein.

3.2 Design, construction, and physical dimensions. The design, construction, and physical dimensions shall be as specified in MIL-PRF-38535 and herein for device classes Q and V or MIL-PRF-38535, appendix A and herein for device class M.

3.2.1 Case outlines. The case outlines shall be in accordance with 1.2.4 herein.

3.2.2 Terminal connections. The terminal connections shall be as specified on figure 1.

3.2.3 Truth table. The truth table shall be as specified on figure 2.

3.2.4 Logic diagram. The logic diagram shall be as specified on figure 3.

3.2.5 Switching waveforms and test circuit. The switching waveforms and test circuit shall be as specified in figure 4.

3.3 Electrical performance characteristics and postirradiation parameter limits. Unless otherwise specified herein, the electrical performance characteristics and postirradiation parameter limits are as specified in table I and shall apply over the full case operating temperature range.

3.4 Electrical test requirements. The electrical test requirements shall be the subgroups specified in table II. The electrical tests for each subgroup are defined in table I.

STANDARD MICROCIRCUIT DRAWING DLA LAND AND MARITIME COLUMBUS, OHIO 43218-3990	SIZE A		5962-86891
		REVISION LEVEL E	SHEET 4

3.5 Marking. The part shall be marked with the PIN listed in 1.2 herein. In addition, the manufacturer's PIN may also be marked. For packages where marking of the entire SMD PIN number is not feasible due to space limitations, the manufacturer has the option of not marking the "5962-" on the device. For RHA product using this option, the RHA designator shall still be marked. Marking for device classes Q and V shall be in accordance with MIL-PRF-38535. Marking for device class M shall be in accordance with MIL-PRF-38535, appendix A.

3.5.1 Certification/compliance mark. The certification mark for device classes Q and V shall be a "QML" or "Q" as required in MIL-PRF-38535. The compliance mark for device class M shall be a "C" as required in MIL-PRF-38535, appendix A.

3.6 Certificate of compliance. For device classes Q and V, a certificate of compliance shall be required from a QML-38535 listed manufacturer in order to supply to the requirements of this drawing (see 6.6.1 herein). For device class M, a certificate of compliance shall be required from a manufacturer in order to be listed as an approved source of supply in MIL-HDBK-103 (see 6.6.2 herein). The certificate of compliance submitted to DLA Land and Maritime-VA prior to listing as an approved source of supply for this drawing shall affirm that the manufacturer's product meets, for device classes Q and V, the requirements of MIL-PRF-38535 and herein or for device class M, the requirements of MIL-PRF-38535, appendix A and herein.

3.7 Certificate of conformance. A certificate of conformance as required for device classes Q and V in MIL-PRF-38535 or for device class M in MIL-PRF-38535, appendix A shall be provided with each lot of microcircuits delivered to this drawing.

3.8 Notification of change for device class M. For device class M, notification to DLA Land and Maritime-VA of change of product (see 6.2 herein) involving devices acquired to this drawing is required for any change that affects this drawing.

3.9 Verification and review for device class M. For device class M, DLA Land and Maritime, DLA Land and Maritime's agent, and the acquiring activity retain the option to review the manufacturer's facility and applicable required documentation. Offshore documentation shall be made available onshore at the option of the reviewer.

3.10 Microcircuit group assignment for device class M. Device class M devices covered by this drawing shall be in microcircuit group number 40 (see MIL-PRF-38535, appendix A).

STANDARD MICROCIRCUIT DRAWING DLA LAND AND MARITIME COLUMBUS, OHIO 43218-3990	SIZE A		5962-86891
		REVISION LEVEL E	SHEET 5

TABLE I. Electrical performance characteristics.

Test	Symbol	Test conditions <u>1/</u> -55°C ≤ T _c ≤ +125°C unless otherwise specified		Group A subgroups	Limits		Unit
					Min	Max	
High level output voltage	V _{OH}	V _{IN} = V _{IH} minimum or V _{IL} maximum I _{OH} = -20 μA	V _{CC} = 2.0 V	1, 2, 3	1.9		V
			V _{CC} = 4.5 V		4.4		
			V _{CC} = 6.0 V		5.9		
		V _{IN} = V _{IH} minimum or V _{IL} maximum I _{OH} = -4.0 mA	V _{CC} = 4.5 V	1	3.98		
				2, 3	3.7		
		V _{IN} = V _{IH} minimum or V _{IL} maximum I _{OH} = -5.2 mA	V _{CC} = 6.0 V	1	5.48		
	2, 3		5.2				
Low level output voltage	V _{OL}	V _{IN} = V _{IH} minimum or V _{IL} maximum I _{OL} = 20 μA	V _{CC} = 2.0 V	1, 2, 3		0.1	V
			V _{CC} = 4.5 V			0.1	
			V _{CC} = 6.0 V			0.1	
		V _{IN} = V _{IH} minimum or V _{IL} maximum I _{OL} = 4.0 mA	V _{CC} = 4.5 V	1		0.26	
				2, 3		0.4	
		V _{IN} = V _{IH} minimum or V _{IL} maximum I _{OL} = 5.2 mA	V _{CC} = 6.0 V	1		0.26	
	2, 3			0.4			
High level input voltage	V _{IH} <u>2/</u>		V _{CC} = 2.0 V	1, 2, 3	1.5		V
			V _{CC} = 4.5 V		3.15		
			V _{CC} = 6.0 V		4.2		
Low level input voltage	V _{IL} <u>2/</u>		V _{CC} = 2.0 V	1, 2, 3		0.3	V
			V _{CC} = 4.5 V			0.9	
			V _{CC} = 6.0 V			1.2	
Input capacitance	C _{IN}	V _{IN} = V _{CC} or GND, T _c = +25°C, I _{OUT} = 0 V, See 4.4.1c		4		10.0	pF
Quiescent supply current	I _{CC}	V _{IN} = V _{CC} or GND V _{CC} = 6.0 V, I _o = 0 μA		1		8.0	μA
				2, 3		160.0	

See footnotes at end of table.

**STANDARD
MICROCIRCUIT DRAWING**
DLA LAND AND MARITIME
COLUMBUS, OHIO 43218-3990

SIZE
A

REVISION LEVEL
E

5962-86891

SHEET
6

TABLE I. Electrical performance characteristics - Continued.

Test	Symbol	Test conditions <u>1</u> / -55°C ≤ T _C ≤ +125°C unless otherwise specified		Group A subgroups	Limits		Unit
					Min	Max	
Input leakage current	I _{IN}	V _{CC} = 6.0 V, V _{IN} = V _{CC} or GND		1		±0.1	μA
				2, 3		±1.0	
Functional tests		See 4.4.1b		7, 8			
Power dissipation capacitance	C _{PD}	See 4.4.1c		4		112.0	pF
Maximum operating frequency	f _{MAX}	T _C = +25°C C _L = 50 pF See figure 4	V _{CC} = 2.0 V	9	4.2		MHz
			V _{CC} = 4.5 V		21		
			V _{CC} = 6.0 V		24		
		T _C = -55°C, +125°C C _L = 50 pF See figure 4	V _{CC} = 2.0 V	10, 11	2.8		MHz
			V _{CC} = 4.5 V		14		
			V _{CC} = 6.0 V		16		
Minimum setup time, data before LOAD↑	t _{SU1}	T _C = +25°C C _L = 50 pF See figure 4	V _{CC} = 2.0 V	9	150		ns
			V _{CC} = 4.5 V		30		
			V _{CC} = 6.0 V		25		
		T _C = -55°C, +125°C C _L = 50 pF See figure 4	V _{CC} = 2.0 V	10, 11	230		ns
			V _{CC} = 4.5 V		46		
			V _{CC} = 6.0 V		38		
Minimum setup time, CTEN or D/U before CLK↑	t _{SU2}	T _C = +25°C C _L = 50 pF See figure 4	V _{CC} = 2.0 V	9	205		ns
			V _{CC} = 4.5 V		41		
			V _{CC} = 6.0 V		35		
		T _C = -55°C, +125°C C _L = 50 pF See figure 4	V _{CC} = 2.0 V	10, 11	306		ns
			V _{CC} = 4.5 V		61		
			V _{CC} = 6.0 V		53		

See footnotes at end of table.

**STANDARD
MICROCIRCUIT DRAWING**
DLA LAND AND MARITIME
COLUMBUS, OHIO 43218-3990

SIZE
A

REVISION LEVEL
E

5962-86891

SHEET
7

TABLE I. Electrical performance characteristics - Continued.

Test	Symbol	Test conditions <u>1/</u> -55°C ≤ T _C ≤ +125°C unless otherwise specified		Group A subgroups	Limits		Unit
					Min	Max	
Minimum hold time, data after <u>LOAD</u>	t _{H1}	T _C = +25°C C _L = 50 pF See figure 4	V _{CC} = 2.0 V	9	5		ns
			V _{CC} = 4.5 V		5		
			V _{CC} = 6.0 V		5		
		T _C = -55°C, +125°C C _L = 50 pF See figure 4	V _{CC} = 2.0 V	10, 11	5		ns
			V _{CC} = 4.5 V		5		
			V _{CC} = 6.0 V		5		
Minimum hold time, <u>CTEN</u> or <u>D/U</u> after <u>CLK</u> ↑	t _{H2}	T _C = +25°C C _L = 50 pF See figure 4	V _{CC} = 2.0 V	9	5		ns
			V _{CC} = 4.5 V		5		
			V _{CC} = 6.0 V		5		
		T _C = -55°C, +125°C C _L = 50 pF See figure 4	V _{CC} = 2.0 V	10, 11	5		ns
			V _{CC} = 4.5 V		5		
			V _{CC} = 6.0 V		5		
Pulse duration, <u>LOAD</u> low or <u>CLK</u> high or low	t _w	T _C = +25°C C _L = 50 pF See figure 4	V _{CC} = 2.0 V	9	125		ns
			V _{CC} = 4.5 V		25		
			V _{CC} = 6.0 V		21		
		T _C = -55°C, +125°C C _L = 50 pF See figure 4	V _{CC} = 2.0 V	10, 11	190		ns
			V _{CC} = 4.5 V		38		
			V _{CC} = 6.0 V		32		

See footnotes at end of table.

**STANDARD
MICROCIRCUIT DRAWING**
DLA LAND AND MARITIME
COLUMBUS, OHIO 43218-3990

SIZE
A

REVISION LEVEL
E

5962-86891

SHEET
8

TABLE I. Electrical performance characteristics - Continued.

Test	Symbol	Test conditions <u>1/</u> -55°C ≤ T _C ≤ +125°C unless otherwise specified		Group A subgroups	Limits		Unit
					Min	Max	
Minimum recovery time, LOAD inactive before CLK↑	t _{REC}	T _C = +25°C C _L = 50 pF See figure 4	V _{CC} = 2.0 V	9	150		ns
			V _{CC} = 4.5 V		30		
			V _{CC} = 6.0 V		25		
		T _C = -55°C, +125°C C _L = 50 pF See figure 4	V _{CC} = 2.0 V	10, 11	225		ns
			V _{CC} = 4.5 V		30		
			V _{CC} = 6.0 V		38		
Propagation delay time, LOAD to Q _A , Q _B , Q _C or Q _D	t _{PHL1} , t _{PLH1} <u>3/</u>	T _C = +25°C C _L = 50 pF See figure 4	V _{CC} = 2.0 V	9		264	ns
			V _{CC} = 4.5 V			53	
			V _{CC} = 6.0 V			45	
		T _C = -55°C, +125°C C _L = 50 pF See figure 4	V _{CC} = 2.0 V	10, 11		396	ns
			V _{CC} = 4.5 V			79	
			V _{CC} = 6.0 V			67	
Propagation delay, data A, B, C, or D to Q _A , Q _B , Q _C or Q _D	t _{PHL2} , t _{PLH2} <u>3/</u>	T _C = +25°C C _L = 50 pF See figure 4	V _{CC} = 2.0 V	9		240	ns
			V _{CC} = 4.5 V			48	
			V _{CC} = 6.0 V			41	
		T _C = -55°C, +125°C C _L = 50 pF See figure 4	V _{CC} = 2.0 V	10, 11		360	ns
			V _{CC} = 4.5 V			72	
			V _{CC} = 6.0 V			61	

See footnotes at end of table.

**STANDARD
MICROCIRCUIT DRAWING**
DLA LAND AND MARITIME
COLUMBUS, OHIO 43218-3990

SIZE
A

REVISION LEVEL
E

5962-86891

SHEET
9

TABLE I. Electrical performance characteristics - Continued.

Test	Symbol	Test conditions <u>1/</u> -55°C ≤ T _C ≤ +125°C unless otherwise specified		Group A subgroups	Limits		Unit
					Min	Max	
Propagation delay time, CLK to RCO (ripple clock output)	t _{PHL3} , t _{PLH3} <u>3/</u>	T _C = +25°C C _L = 50 pF See figure 4	V _{CC} = 2.0 V	9		120	ns
			V _{CC} = 4.5 V			24	
			V _{CC} = 6.0 V			21	
	T _C = -55°C, +125°C C _L = 50 pF See figure 4	V _{CC} = 2.0 V	10, 11		180	ns	
		V _{CC} = 4.5 V			36		
		V _{CC} = 6.0 V			31		
Propagation delay time, CLK to Q _A , Q _B , Q _C , Q _D	t _{PHL4} , t _{PLH4} <u>3/</u>	T _C = +25°C C _L = 50 pF See figure 4	V _{CC} = 2.0 V	9		192	ns
			V _{CC} = 4.5 V			38	
			V _{CC} = 6.0 V			32	
	T _C = -55°C, +125°C C _L = 50 pF See figure 4	V _{CC} = 2.0 V	10, 11		288	ns	
		V _{CC} = 4.5 V			58		
		V _{CC} = 6.0 V			49		
Propagation delay time, CLK to MAX/MIN	t _{PHL5} , t _{PLH5} <u>3/</u>	T _C = +25°C C _L = 50 pF See figure 4	V _{CC} = 2.0 V	9		252	ns
			V _{CC} = 4.5 V			50	
			V _{CC} = 6.0 V			43	
	T _C = -55°C, +125°C C _L = 50 pF See figure 4	V _{CC} = 2.0 V	10, 11		378	ns	
		V _{CC} = 4.5 V			76		
		V _{CC} = 6.0 V			65		

See footnotes at end of table.

**STANDARD
MICROCIRCUIT DRAWING**
DLA LAND AND MARITIME
COLUMBUS, OHIO 43218-3990

SIZE
A

REVISION LEVEL
E

5962-86891

SHEET
10

TABLE I. Electrical performance characteristics - Continued.

Test	Symbol	Test conditions 1/ -55°C ≤ T _C ≤ +125°C unless otherwise specified		Group A subgroups	Limits		Unit
					Min	Max	
Propagation delay time, D/U to RCO (ripple clock output)	t _{PHL6} , t _{PLH6} 3/	T _C = +25°C C _L = 50 pF See figure 4	V _{CC} = 2.0 V	9		228	ns
			V _{CC} = 4.5 V			46	
			V _{CC} = 6.0 V			38	
	T _C = -55°C, +125°C C _L = 50 pF See figure 4	V _{CC} = 2.0 V	10, 11		342	ns	
		V _{CC} = 4.5 V			68		
		V _{CC} = 6.0 V			59		
Propagation delay time, D/U to MAX/MIN	t _{PHL7} , t _{PLH7} 3/	T _C = +25°C C _L = 50 pF See figure 4	V _{CC} = 2.0 V	9		192	ns
			V _{CC} = 4.5 V			38	
			V _{CC} = 6.0 V			32	
	T _C = -55°C, +125°C C _L = 50 pF See figure 4	V _{CC} = 2.0 V	10, 11		288	ns	
		V _{CC} = 4.5 V			58		
		V _{CC} = 6.0 V			49		
Propagation delay time, CTENto RCO (ripple clock output)	t _{PHL8} , t _{PLH8} 3/	T _C = +25°C C _L = 50 pF See figure 4	V _{CC} = 2.0 V	9		132	ns
			V _{CC} = 4.5 V			26	
			V _{CC} = 6.0 V			23	
	T _C = -55°C, +125°C C _L = 50 pF See figure 4	V _{CC} = 2.0 V	10, 11		198	ns	
		V _{CC} = 4.5 V			40		
		V _{CC} = 6.0 V			34		

See footnotes at end of table.

**STANDARD
MICROCIRCUIT DRAWING**
DLA LAND AND MARITIME
COLUMBUS, OHIO 43218-3990

SIZE
A

REVISION LEVEL
E

5962-86891

SHEET
11

TABLE I. Electrical performance characteristics - Continued.

Test	Symbol	Test conditions <u>1/</u> -55°C ≤ T _C ≤ +125°C unless otherwise specified		Group A subgroups	Limits		Unit
					Min	Max	
Transition time, high to low, low to high	t _{THL} , t _{TLH} <u>4/</u>	T _C = +25°C C _L = 50 pF See figure 4	V _{CC} = 2.0 V	9		75	ns
			V _{CC} = 4.5 V			15	
			V _{CC} = 6.0 V			13	
	T _C = -55°C, +125°C C _L = 50 pF See figure 4	V _{CC} = 2.0 V	10, 11		110	ns	
		V _{CC} = 4.5 V			22		
		V _{CC} = 6.0 V			19		

1/ For a power supply of 5 V ±10%, the worst case output voltages (V_{OH} and V_{OL}) occur for HC at 4.5 V. Thus, the 4.5 V values should be used when designing with this supply. Worst cases V_{IH} and V_{IL} occur at V_{CC} = 5.5 V and 4.5 V respectively. (The V_{IH} value at 5.5 V is 3.85 V.) The worst case leakage currents (I_{IN} and I_{CC}) occur for CMOS at the higher voltage, so the 6.0 V values should be used. Power dissipation capacitance (C_{PD}), typically 50 pF per latch, determines the no load dynamic power consumption, P_D = (C_{PD} V_{CC}² f) + (I_{CC} V_{CC}), and the no load dynamic current consumption, I_S = C_{PD} V_{CC} f + I_{CC}.

2/ V_{IH} and V_{IL} tests are not required and shall be applied as forcing functions for the V_{OH} or V_{OL} tests.

3/ AC testing at V_{CC} = 2.0 V and V_{CC} = 6.0 V shall be guaranteed, if not tested, to the specified limits.

4/ Transition time (t_{TLH}, t_{THL}), if not tested, shall be guaranteed to the specified limits in table I.

STANDARD MICROCIRCUIT DRAWING DLA LAND AND MARITIME COLUMBUS, OHIO 43218-3990	SIZE A		5962-86891
		REVISION LEVEL E	SHEET 12

Device type	01	
Case Outline	E and X	2
Terminal Number	Terminal Symbol	Terminal Symbol
1	B	NC
2	Q _B	B
3	Q _A	Q _B
4	$\overline{\text{CTEN}}$	Q _A
5	D/U	$\overline{\text{CTEN}}$
6	Q _C	NC
7	Q _D	D/U
8	GND	Q _C
9	D	Q _D
10	C	GND
11	$\overline{\text{LOAD}}$	NC
12	MAX/MIN	D
13	$\overline{\text{RCO}}$	C
14	CLK	$\overline{\text{LOAD}}$
15	A	MAX/MIN
16	V _{CC}	NC
17	- - -	$\overline{\text{RCO}}$
18	- - -	CLK
19	- - -	A
20	- - -	V _{CC}

NC = No internal connection

FIGURE 1. Terminal connections.

$\overline{\text{LOAD}}$	$\overline{\text{CTEN}}$	D/U	CLK	FUNCTION
H	L	L	↑	Count up
H	L	H	↑	Count down
L	X	X	X	Load
H	H	X	X	No change

H = High voltage level (steady state)

L = Low voltage level (steady state)

X = Irrelevant (any input including transistors)

↑ = Transition from low to high level

Asynchronous inputs; Low input to load sets Q_A = A, Q_B = B, Q_C = C and Q_D = D.

FIGURE 2. Truth table.

STANDARD MICROCIRCUIT DRAWING DLA LAND AND MARITIME COLUMBUS, OHIO 43218-3990	SIZE A		5962-86891
		REVISION LEVEL E	SHEET 13

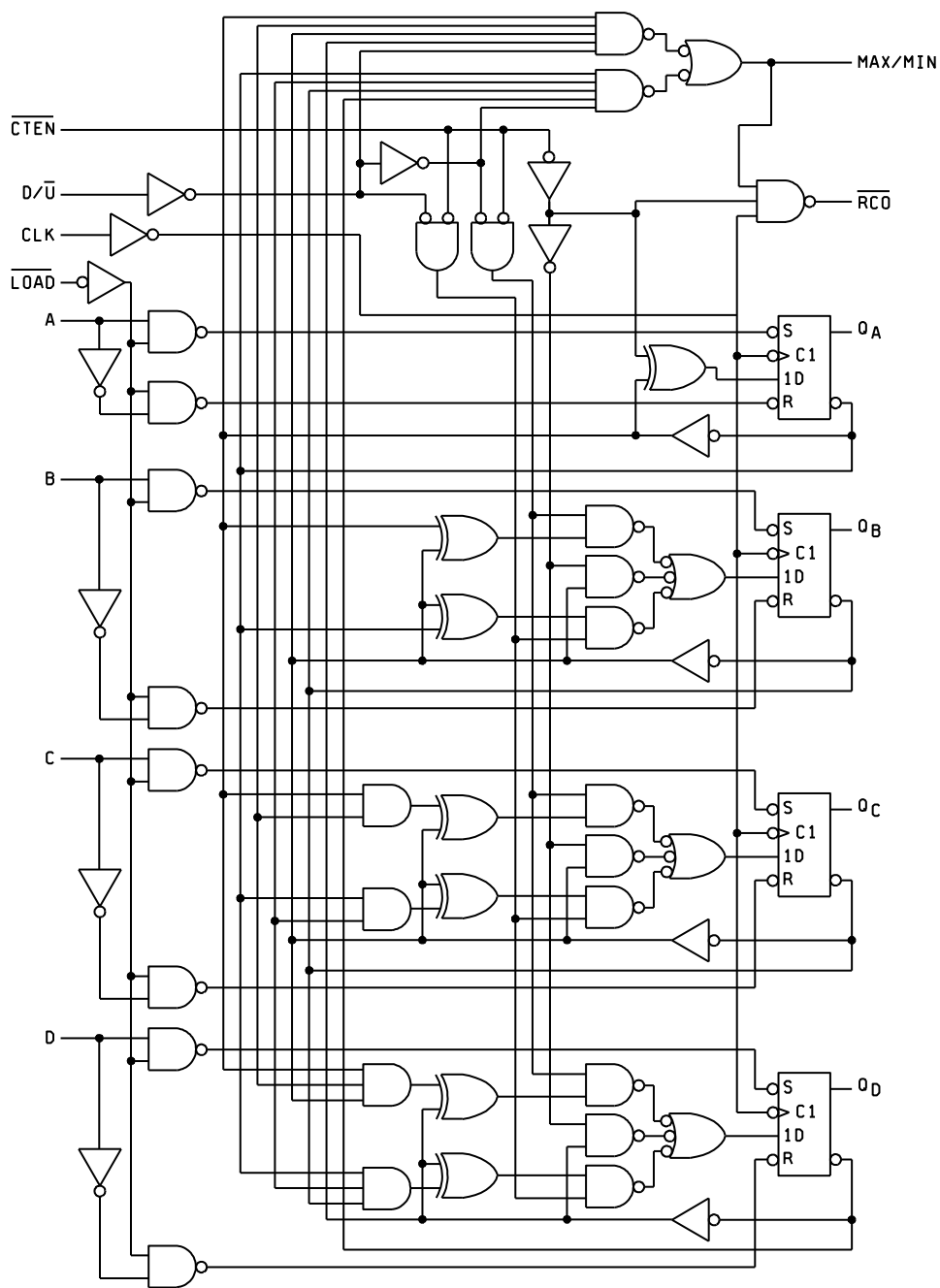

FIGURE 3. Logic diagram.

**STANDARD
MICROCIRCUIT DRAWING**
DLA LAND AND MARITIME
COLUMBUS, OHIO 43218-3990

SIZE
A

5962-86891

REVISION LEVEL
E

SHEET
14

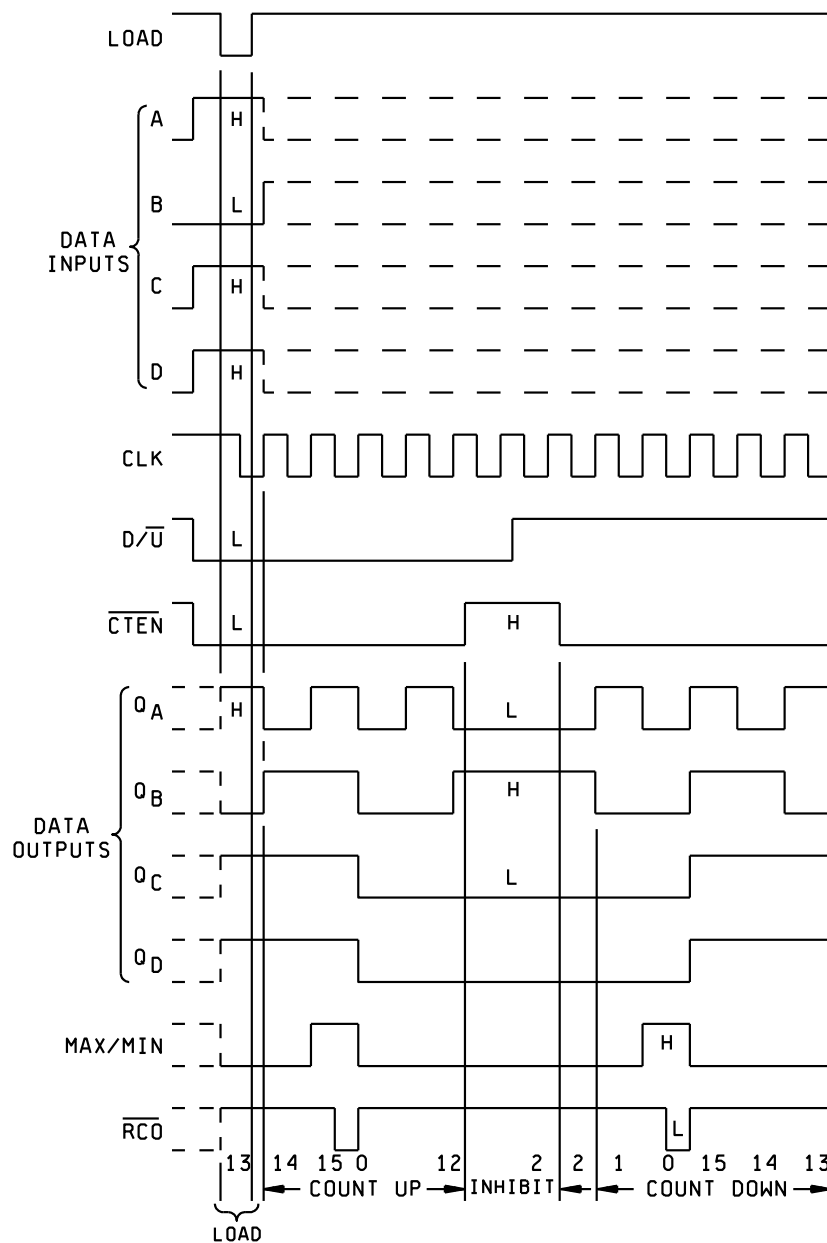

Sequence:

- (1) Load (preset) to binary thirteen
- (2) Count up to fourteen, fifteen, zero, one, and two
- (3) Inhibit
- (4) Count down to one, zero (minimum), fifteen, fourteen, and thirteen

FIGURE 4. Switching waveforms and test circuit.

**STANDARD
MICROCIRCUIT DRAWING**
DLA LAND AND MARITIME
COLUMBUS, OHIO 43218-3990

SIZE
A

REVISION LEVEL
E

5962-86891

SHEET
15

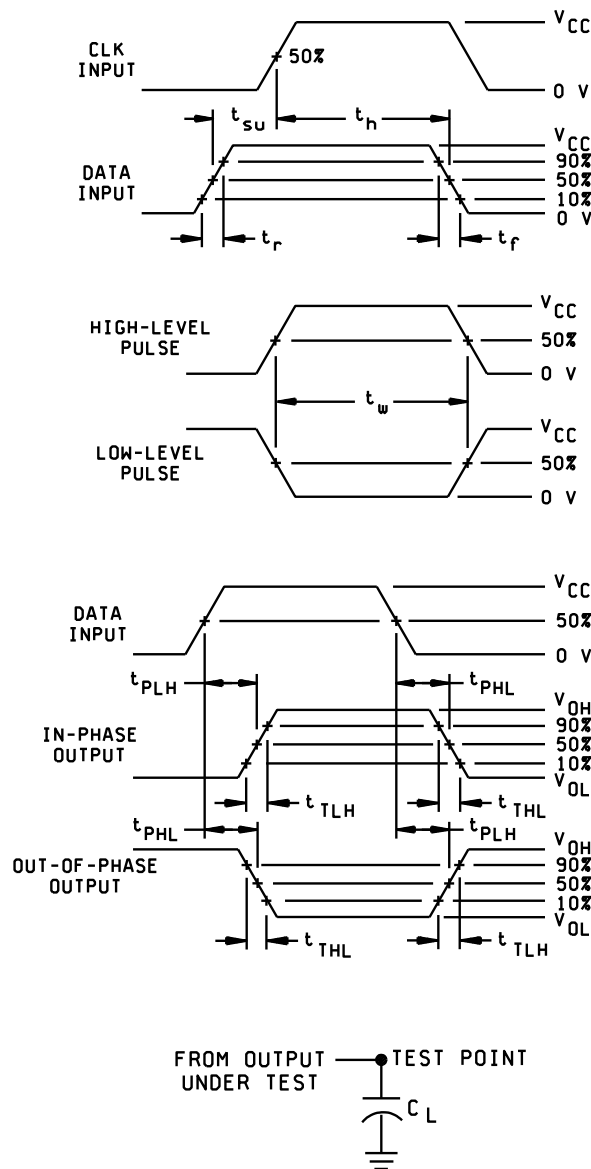

NOTES:

1. $C_L = 50$ pF minimum or equivalent (includes probe and test fixture capacitance).
2. Phase relationships between waveforms were chosen arbitrarily. All input pulses are supplied by generators having the following characteristics: $PRR \leq 1$ MHz, $Z_o = 50\Omega$, $t_r = 6.0$ ns, $t_f = 6.0$ ns.
3. The outputs are measured one at a time with one input transition per measurement.
4. Timing parameters shall be tested at a minimum input frequency of 1 MHz.

FIGURE 4. Switching waveforms and test circuit - Continued.

STANDARD MICROCIRCUIT DRAWING DLA LAND AND MARITIME COLUMBUS, OHIO 43218-3990	SIZE A		5962-86891
		REVISION LEVEL E	SHEET 16

4. VERIFICATION

4.1 Sampling and inspection. For device classes Q and V, sampling and inspection procedures shall be in accordance with MIL-PRF-38535 or as modified in the device manufacturer's Quality Management (QM) plan. The modification in the QM plan shall not affect the form, fit, or function as described herein. For device class M, sampling and inspection procedures shall be in accordance with MIL-PRF-38535, appendix A.

4.2 Screening. For device classes Q and V, screening shall be in accordance with MIL-PRF-38535, and shall be conducted on all devices prior to qualification and technology conformance inspection. For device class M, screening shall be in accordance with method 5004 of MIL-STD-883, and shall be conducted on all devices prior to quality conformance inspection.

4.2.1 Additional criteria for device class M.

- a. Burn-in test, method 1015 of MIL-STD-883.
 - (1) Test condition A, B, C, or D. The test circuit shall be maintained by the manufacturer under document revision level control and shall be made available to the preparing or acquiring activity upon request. The test circuit shall specify the inputs, outputs, biases, and power dissipation, as applicable, in accordance with the intent specified in method 1015.
 - (2) $T_A = +125^{\circ}\text{C}$, minimum.
- b. Interim and final electrical test parameters shall be as specified in table II herein.

4.2.2 Additional criteria for device classes Q and V.

- a. The burn-in test duration, test condition and test temperature, or approved alternatives shall be as specified in the device manufacturer's QM plan in accordance with MIL-PRF-38535. The burn-in test circuit shall be maintained under document revision level control of the device manufacturer's Technology Review Board (TRB) in accordance with MIL-PRF-38535 and shall be made available to the acquiring or preparing activity upon request. The test circuit shall specify the inputs, outputs, biases, and power dissipation, as applicable, in accordance with the intent specified in method 1015 of MIL-STD-883.
- b. Interim and final electrical test parameters shall be as specified in table II herein.
- c. Additional screening for device class V beyond the requirements of device class Q shall be as specified in MIL-PRF-38535, appendix B.

4.3 Qualification inspection for device classes Q and V. Qualification inspection for device classes Q and V shall be in accordance with MIL-PRF-38535. Inspections to be performed shall be those specified in MIL-PRF-38535 and herein for groups A, B, C, D, and E inspections (see 4.4.1 through 4.4.4).

4.4 Conformance inspection. Technology conformance inspection for classes Q and V shall be in accordance with MIL-PRF-38535 including groups A, B, C, D, and E inspections and as specified. Quality conformance inspection for device class M shall be in accordance with MIL-PRF-38535, appendix A and as specified herein. Inspections to be performed for device class M shall be those specified in method 5005 of MIL-STD-883 and herein for groups A, B, C, D, and E inspections (see 4.4.1 through 4.4.4).

4.4.1 Group A inspection.

- a. Tests shall be as specified in table II herein.
- b. For device class M, subgroups 7 and 8 tests shall be sufficient to verify the truth table in figure 2 herein. The test vectors used to verify the truth table shall, at a minimum, test all functions of each input and output. All possible input to output logic patterns per function shall be guaranteed, if not tested, to the truth table in figure 2, herein. For device classes Q and V, subgroups 7 and 8 shall include verifying the functionality of the device.
- c. C_{IN} shall be measured only for initial qualification and after process or design changes which may affect capacitance. C_{IN} shall be measured between the designated terminal and GND at a frequency of 1 MHz. C_{PD} shall be tested in accordance with the latest revision of JESD20 and table I herein. For C_{IN} and C_{PD} , test all applicable pins on five devices with zero failures.

STANDARD MICROCIRCUIT DRAWING DLA LAND AND MARITIME COLUMBUS, OHIO 43218-3990	SIZE A		5962-86891
		REVISION LEVEL E	SHEET 17

TABLE II. Electrical test requirements.

Test requirements	Subgroups (in accordance with MIL-STD-883, method 5005, table I)	Subgroups (in accordance with MIL-PRF-38535, table III)	
	Device class M	Device class Q	Device class V
Interim electrical parameters (see 4.2)	---	---	1
Final electrical parameters (see 4.2)	1, 2, 3, 7, 9 <u>1/</u>	1, 2, 3, 7, 9 <u>1/</u>	1, 2, 3, 7, 8, 9, 10, 11 <u>2/</u> <u>3/</u>
Group A test requirements (see 4.4)	1, 2, 3, 4, 7, 9, 10, 11	1, 2, 3, 4, 7, 8, 9, 10, 11	1, 2, 3, 4, 7, 8, 9, 10, 11
Group C end-point electrical parameters (see 4.4)	1, 2, 3	1, 2, 3	1, 2, 3, 7, 8 9, 10, 11 <u>3/</u>
Group D end-point electrical parameters (see 4.4)	1, 2, 3	1, 2, 3	1, 2, 3
Group E end-point electrical parameters (see 4.4)	1, 7, 9	1, 7, 9	1, 7, 9

1/ PDA applies to subgroup 1.

2/ PDA applies to subgroups 1, 7 and deltas.

3/ Delta limits as specified in table III shall be required where specified, and the delta limits shall be completed with reference to the zero hour electrical parameters.

TABLE III. Burn-in and operating life test, delta parameters (+25°C)

Parameter	Symbol	Delta Limits
Quiescent current	I _{CC}	±120 nA
Input current low level	I _{IL}	±20 nA
Input current high level	I _{IH}	±20 nA
Output voltage low level (I _{OL} = 4 mA, V _{CC} = 4.5 V)	V _{OL}	±0.026 V
Output voltage high level (I _{OH} = -4 mA, V _{CC} = 4.5 V)	V _{OH}	±0.20 V

4.4.2 Group C inspection. The group C inspection end-point electrical parameters shall be as specified in table II herein.

STANDARD MICROCIRCUIT DRAWING DLA LAND AND MARITIME COLUMBUS, OHIO 43218-3990	SIZE A		5962-86891
		REVISION LEVEL E	SHEET 18

4.4.2.1 Additional criteria for device class M. Steady-state life test conditions, method 1005 of MIL-STD-883:

- a. Test condition A, B, C, or D. The test circuit shall be maintained by the manufacturer under document revision level control and shall be made available to the preparing or acquiring activity upon request. The test circuit shall specify the inputs, outputs, biases, and power dissipation, as applicable, in accordance with the intent specified in method 1005 of MIL-STD-883.
- b. $T_A = +125^{\circ}\text{C}$, minimum.
- c. Test duration: 1,000 hours, except as permitted by method 1005 of MIL-STD-883.

4.4.2.2 Additional criteria for device classes Q and V. The steady-state life test duration, test condition and test temperature, or approved alternatives shall be as specified in the device manufacturer's QM plan in accordance with MIL-PRF-38535. The test circuit shall be maintained under document revision level control by the device manufacturer's TRB in accordance with MIL-PRF-38535 and shall be made available to the acquiring or preparing activity upon request. The test circuit shall specify the inputs, outputs, biases, and power dissipation, as applicable, in accordance with the intent specified in method 1005 of MIL-STD-883.

4.4.3 Group D inspection. The group D inspection end-point electrical parameters shall be as specified in table II herein.

4.4.4 Group E inspection. Group E inspection is required only for parts intended to be marked as radiation hardness assured (see 3.5 herein).

- a. End-point electrical parameters shall be as specified in table II herein.
- b. For device classes Q and V, the devices or test vehicle shall be subjected to radiation hardness assured tests as specified in MIL-PRF-38535 for the RHA level being tested. For device class M, the devices shall be subjected to radiation hardness assured tests as specified in MIL-PRF-38535, appendix A for the RHA level being tested. All device classes must meet the postirradiation end-point electrical parameter limits as defined in table I at $T_A = +25^{\circ}\text{C} \pm 5^{\circ}\text{C}$, after exposure, to the subgroups specified in table II herein.

4.5 Methods of inspection. Methods of inspection shall be specified as follows:

4.5.1 Voltage and current. Unless otherwise specified, all voltages given are referenced to the microcircuit GND terminal. Currents given are conventional current and positive when flowing into the referenced terminal.

5. PACKAGING

5.1 Packaging requirements. The requirements for packaging shall be in accordance with MIL-PRF-38535 for device classes Q and V or MIL-PRF-38535, appendix A for device class M.

6. NOTES

6.1 Intended use. Microcircuits conforming to this drawing are intended for use for Government microcircuit applications (original equipment), design applications, and logistics purposes.

6.1.1 Replaceability. Microcircuits covered by this drawing will replace the same generic device covered by a contractor-prepared specification or drawing.

6.2 Configuration control of SMD's. All proposed changes to existing SMD's will be coordinated with the users of record for the individual documents. This coordination will be accomplished using DD Form 1692, Engineering Change Proposal.

6.3 Record of users. Military and industrial users should inform DLA Land and Maritime when a system application requires configuration control and which SMD's are applicable to that system. DLA Land and Maritime will maintain a record of users and this list will be used for coordination and distribution of changes to the drawings. Users of drawings covering microelectronic devices (FSC 5962) should contact DLA Land and Maritime-VA, telephone (614) 692-8108.

6.4 Comments. Comments on this drawing should be directed to DLA Land and Maritime-VA, Columbus, Ohio 43218-3990, or telephone (614) 692-0591.

STANDARD MICROCIRCUIT DRAWING DLA LAND AND MARITIME COLUMBUS, OHIO 43218-3990	SIZE A		5962-86891
		REVISION LEVEL E	SHEET 19

6.5 Abbreviations, symbols, and definitions. The abbreviations, symbols, and definitions used herein are defined in MIL-PRF-38535 and MIL-HDBK-1331.

6.6 Sources of supply.

6.6.1 Sources of supply for device classes Q and V. Sources of supply for device classes Q and V are listed in MIL-HDBK-103 and QML-38535. The vendors listed in MIL-HDBK-103 and QML-38535 have submitted a certificate of compliance (see 3.6 herein) to DLA Land and Maritime-VA and have agreed to this drawing.

6.6.2 Approved sources of supply for device class M. Approved sources of supply for class M are listed in MIL-HDBK-103. The vendors listed in MIL-HDBK-103 have agreed to this drawing and a certificate of compliance (see 3.6 herein) has been submitted to and accepted by DLA Land and Maritime-VA.

STANDARD MICROCIRCUIT DRAWING DLA LAND AND MARITIME COLUMBUS, OHIO 43218-3990	SIZE A		5962-86891
		REVISION LEVEL E	SHEET 20

STANDARD MICROCIRCUIT DRAWING BULLETIN

DATE: 21-02-05

Approved sources of supply for SMD 5962-86891 are listed below for immediate acquisition information only and shall be added to MIL-HDBK-103 and QML-38535 during the next revision. MIL-HDBK-103 and QML-38535 will be revised to include the addition or deletion of sources. The vendors listed below have agreed to this drawing and a certificate of compliance has been submitted to and accepted by DLA Land and Maritime-VA. This information bulletin is superseded by the next dated revision of MIL-HDBK-103 and QML-38535. DLA Land and Maritime maintains an online database of all current sources of supply at <https://landandmaritimeapps.dla.mil/programs/smcr/>.

Standard microcircuit drawing PIN <u>1/</u>	Vendor CAGE number	Vendor similar PIN <u>2/</u>
5962-8689101EA	01295	SNJ54HC191J
		CD54HC191F3A
5962-86891012A	01295	SNJ54HC191FK
5962-8689101XA	<u>3/</u>	54HC191K02Q
5962-8689101XC	<u>3/</u>	54HC191K01Q
5962-8689101VXA	<u>3/</u>	54HC191K02V
5962-8689101VXC	<u>3/</u>	54HC191K01V

1/ The lead finish shown for each PIN representing a hermetic package is the most readily available from the manufacturer listed for that part. If the desired lead finish is not listed, contact the vendor to determine its availability.

2/ Caution. Do not use this number for item acquisition. Items acquired to this number may not satisfy the performance requirements of this drawing.

3/ Not available from an approved source of supply.

Vendor CAGE
number

01295

Vendor name
and address

Texas Instruments Incorporated
Semiconductor Group
8505 Forest Lane
P.O. Box 660199
Dallas, TX 75243

The information contained herein is disseminated for convenience only and the Government assumes no liability whatsoever for any inaccuracies in the information bulletin.