



1. SCOPE

1.1 Scope. This drawing documents two product assurance class levels consisting of high reliability (device class Q and M) and space application (device class V). A choice of case outlines and lead finishes are available and are reflected in the Part or Identifying Number (PIN). When available, a choice of Radiation Hardness Assurance (RHA) levels is reflected in the PIN.

1.2 PIN. The PIN is as shown in the following examples.

For device class M and Q:

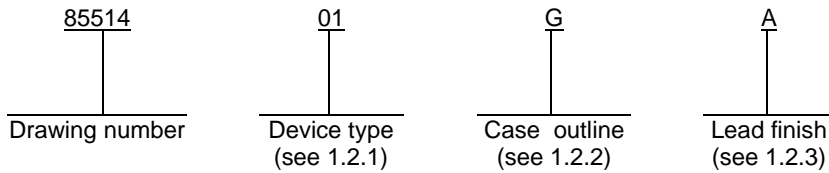

For device class V:

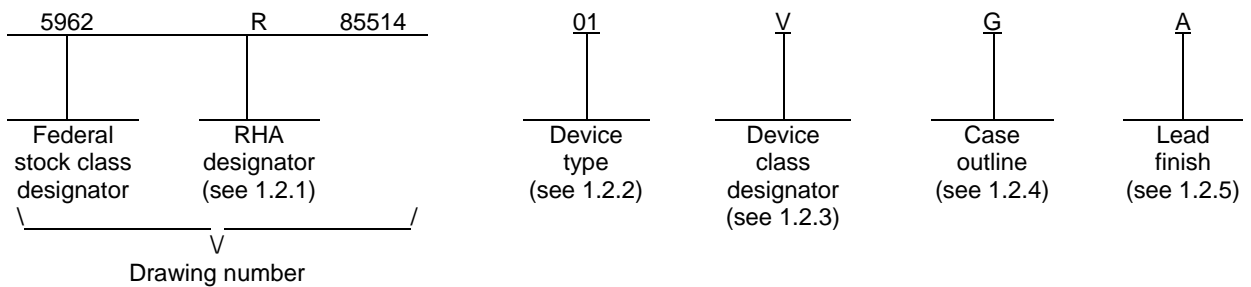

1.2.1 RHA designator. Device classes Q and V RHA marked devices meet the MIL-PRF-38535 specified RHA levels and are marked with the appropriate RHA designator. Device class M RHA marked devices meet the MIL-PRF-38535, appendix A specified RHA levels and are marked with the appropriate RHA designator. A dash (-) indicates a non-RHA device.

1.2.2 Device type(s). The device type(s) identify the circuit function as follows:

<u>Device type</u>	<u>Generic number</u>	<u>Circuit function</u>	<u>Output voltage noise</u>
01	REF02A	Precision reference +5-volt adjustable output	18 μVP-P
02	REF02	Precision reference +5-volt adjustable output	18 μVP-P
03	REF02A	Precision reference +5-volt adjustable output	100 μVP-P
04	REF02	Precision reference +5-volt adjustable output	100 μVP-P
05	REF02A	Radiation hardened, Precision reference +5-volt adjustable output	18 μVP-P

<b>STANDARD MICROCIRCUIT DRAWING</b> DLA LAND AND MARITIME COLUMBUS, OHIO 43218-3990	SIZE <b>A</b>		<b>85514</b>
		REVISION LEVEL <b>L</b>	SHEET <b>2</b>

1.2.3 Device class designator. The device class designator is a single letter identifying the product assurance level as listed below. Since the device class designator has been added after the original issuance of this drawing, device classes M and Q designators will not be included in the PIN and will not be marked on the device.

<u>Device class</u>	<u>Device requirements documentation</u>
M	Vendor self-certification to the requirements for MIL-STD-883 compliant, non-JAN class level B microcircuits in accordance with MIL-PRF-38535, appendix A
Q or V	Certification and qualification to MIL-PRF-38535

1.2.4 Case outline(s). The case outline(s) are as designated in MIL-STD-1835 and as follows:

<u>Outline letter</u>	<u>Descriptive designator</u>	<u>Terminals</u>	<u>Package style</u>
G	MACY1-X8	8	Can
H	GDFP1-F10 or CDFP2-F10	10	Flat pack
P	GDIP1-T8 or CDIP2-T8	8	Dual-in-line
2	CQCC1-N20	20	Square leadless chip carrier

1.2.5 Lead finish. The lead finish is as specified in MIL-PRF-38535 for device classes Q and V or MIL-PRF-38535, appendix A for device class M.

1.3 Absolute maximum ratings. 1/

Input voltage (VIN) .....	40 V dc
Power dissipation (PD) .....	500 mW <u>2/</u>
Output short circuit duration .....	Indefinite
Storage temperature .....	-65°C to +150°C
Lead temperature (soldering, 10 seconds) .....	+300°C
Junction temperature (TJ) .....	+150°C
Thermal resistance, junction-to-case (θJC) .....	See MIL-STD-1835

1.4 Recommended operating conditions.

Ambient operating temperature range (TA) .....	-55°C to +125°C
--	-----------------

1.5 Radiation features:

Device type 01:	
Maximum total dose available (dose rate = 50 – 300 rads(Si)/s) .....	100 krad(Si) <u>3/</u>
Device type 05:	
Maximum total dose available (dose rate ≤ 10 mrad(Si)/s) .....	50 krad(Si) <u>4/</u>

- 1/ Stresses above the absolute maximum rating may cause permanent damage to the device. Extended operation at the maximum levels may degrade performance and affect reliability.
- 2/ Derate 7.1 mW/°C above +80°C for the "G" and "H" packages, 6.6 mW/°C above +75°C for the "P" package, and 7.8 mW/°C above +72°C for the "2" package.
- 3/ Device type 01 may be dose rate sensitive in a space environment and may demonstrate enhanced low dose rate effects. Radiation end point limits for the noted parameters are guaranteed only for the conditions as specified in MIL-STD-883, method 1019, condition A for device type 01.
- 4/ For device type 05, radiation end point limits for the noted parameters are guaranteed for the conditions specified in MIL-STD-883, method 1019, condition D.

<b>STANDARD MICROCIRCUIT DRAWING</b> DLA LAND AND MARITIME COLUMBUS, OHIO 43218-3990	SIZE <b>A</b>		<b>85514</b>
		REVISION LEVEL <b>L</b>	SHEET <b>3</b>

## 2. APPLICABLE DOCUMENTS

2.1 Government specification, standards, and handbooks. The following specification, standards, and handbooks form a part of this drawing to the extent specified herein. Unless otherwise specified, the issues of these documents are those cited in the solicitation or contract.

### DEPARTMENT OF DEFENSE SPECIFICATION

MIL-PRF-38535 - Integrated Circuits, Manufacturing, General Specification for.

### DEPARTMENT OF DEFENSE STANDARDS

MIL-STD-883 - Test Method Standard Microcircuits.  
MIL-STD-1835 - Interface Standard Electronic Component Case Outlines.

### DEPARTMENT OF DEFENSE HANDBOOKS

MIL-HDBK-103 - List of Standard Microcircuit Drawings.  
MIL-HDBK-780 - Standard Microcircuit Drawings.

(Copies of these documents are available online at <http://quicksearch.dla.mil> or from the Standardization Document Order Desk, 700 Robbins Avenue, Building 4D, Philadelphia, PA 19111-5094.)

2.2 Order of precedence. In the event of a conflict between the text of this drawing and the references cited herein, the text of this drawing takes precedence. Nothing in this document, however, supersedes applicable laws and regulations unless a specific exemption has been obtained.

## 3. REQUIREMENTS

3.1 Item requirements. The individual item requirements for device classes Q and V shall be in accordance with MIL-PRF-38535 and as specified herein or as modified in the device manufacturer's Quality Management (QM) plan. The modification in the QM plan shall not affect the form, fit, or function as described herein. The individual item requirements for device class M shall be in accordance with MIL-PRF-38535, appendix A for non-JAN class level B devices and as specified herein.

3.2 Design, construction, and physical dimensions. The design, construction, and physical dimensions shall be as specified in MIL-PRF-38535 and herein for device classes Q and V or MIL-PRF-38535, appendix A and herein for device class M.

3.2.1 Case outlines. The case outlines shall be in accordance with 1.2.4 herein.

3.2.2 Terminal connections. The terminal connections shall be as specified on figure 1.

3.2.3 Radiation exposure circuit. The radiation exposure circuit shall be maintained by the manufacturer under document revision level control and shall be made available to the preparing and acquiring activity upon request.

3.3 Electrical performance characteristics and postirradiation parameter limits. Unless otherwise specified herein, the electrical performance characteristics and postirradiation parameter limits are as specified in table I and shall apply over the full ambient operating temperature range.

3.4 Electrical test requirements. The electrical test requirements shall be the subgroups specified in table IIA. The electrical tests for each subgroup are defined in table I.

<b>STANDARD MICROCIRCUIT DRAWING</b> DLA LAND AND MARITIME COLUMBUS, OHIO 43218-3990	SIZE <b>A</b>		<b>85514</b>
		REVISION LEVEL <b>L</b>	SHEET <b>4</b>

TABLE I. Electrical performance characteristics.

Test	Symbol	Conditions <u>1/</u> -55°C ≤ TA ≤ +125°C unless otherwise specified	Group A subgroups	Device type	Limits		Unit	
					Min	Max		
Quiescent supply current	ISY	No load	1	All		1.4	mA	
			2,3			2.0		
		M,D,P,L,R <u>2/ 3/</u>	1	01		1.4		
		M,D,P,L <u>2/ 3/</u>	1	05		1.4		
Output adjustment <u>4/</u> range	ΔVTRIM	RP = 10 kΩ, TA = +25°C	1	All	±3.0		%	
Output voltage	VO	IL = 0 mA	1	01,03, 05	4.985	5.015	V	
				02,04	4.975	5.025		
		2,3	01,03, 05	4.978	5.022			
			02,04	4.953	5.047			
		M,D,P,L,R <u>2/ 3/</u>	1	01	4.975	5.025		
		M,D,P,L <u>2/ 3/</u>	1	05	4.975	5.025		
Short circuit current <u>4/</u>	IOS	VO = 0 V, TA = +25°C	1	All	+15	+60	mA	
Sink current <u>4/</u>	IS	TA = +25°C	1	All	-0.3		mA	
Load regulation	LD reg	IL = 0 mA to 10 mA <u>5/</u>	1	All		0.01	%mA	
			M,D,P,L,R <u>2/ 3/</u>	1	01			0.015
			M,D,P,L <u>2/ 3/</u>	1	05			0.015
		IL = 0 mA to 8 mA <u>5/</u>	2,3	01,03, 05		0.012		
				02,04		0.015		
Line regulation	LN reg	VIN = 8 V to 33 V <u>5/</u>	1	01,03, 05		0.010	%V	
				02,04		0.012		
		2,3	All		0.015			
			M,D,P,L,R <u>2/ 3/</u>	1	01			0.030
			M,D,P,L <u>2/ 3/</u>	1	05			0.030
Load current	IL	TA = +25°C <u>4/ 6/</u>	1	All	10		mA	
Output voltage noise	enp-p	0.1 Hz to 10 Hz <u>4/</u>	4	01,02, 05		18	μVP-P	
				03,04		100		
Output voltage temperature coefficient	TCVO	<u>4/ 7/</u>	8	01,03, 05		±8.5	ppm/°C	
				02,04		±25		

See footnotes at end of table.

<b>STANDARD MICROCIRCUIT DRAWING</b> DLA LAND AND MARITIME COLUMBUS, OHIO 43218-3990	SIZE <b>A</b>		<b>85514</b>
		REVISION LEVEL <b>L</b>	SHEET <b>5</b>

TABLE I. Electrical performance characteristics – continued.

- 1/ VIN = 15 V. No external components required.
- 2/ Device type 01 supplied to this drawing has been characterized through all levels M, D, P, L, R of irradiation. Device type 05 supplied to this drawing has been characterized through all levels P and L of irradiation. However, device type 01 is only tested at the "R" level and device type 05 is only tested at the "L" level. Pre and Post irradiation values are identical unless otherwise specified in Table I. When performing post irradiation electrical measurements for any RHA level, TA = +25°C.
- 3/ For device type 01, this part may be dose rate sensitive in a space environment and may demonstrate enhanced low dose rate effects. Radiation end point limits for the noted parameters are guaranteed only for the conditions specified in MIL-STD-883, method 1019, condition A for device type 01 and condition D for device type 05. Device type 05, has been tested at low dose rate.
- 4/ This parameter is not tested to post irradiation. Refer to section 6.7 Application notes for more external trim details.
- 5/ Line and load regulation specifications include the effect of self heating.
- 6/ Minimum of 10 mA load current guaranteed by load regulation test.
- 7/  $TCVO = (V_{MAX} - V_{MIN}) / 5 V \times ((-55^{\circ}C \text{ to } +125^{\circ}C) \times (1 \times 10^6)) / 180^{\circ}C$ .

3.5 Marking. The part shall be marked with the PIN listed in 1.2 herein. In addition, the manufacturer's PIN may also be marked. For packages where marking of the entire SMD PIN number is not feasible due to space limitations, the manufacturer has the option of not marking the "5962-" on the device. For RHA product using this option, the RHA designator shall still be marked. Marking for device classes Q and V shall be in accordance with MIL-PRF-38535. Marking for device class M shall be in accordance with MIL-PRF-38535, appendix A.

3.5.1 Certification/compliance mark. The certification mark for device classes Q and V shall be a "QML" or "Q" as required in MIL-PRF-38535. The compliance mark for device class M shall be a "C" as required in MIL-PRF-38535, appendix A.

3.6 Certificate of compliance. For device classes Q and V, a certificate of compliance shall be required from a QML-38535 listed manufacturer in order to supply to the requirements of this drawing (see 6.6.1 herein). For device class M, a certificate of compliance shall be required from a manufacturer in order to be listed as an approved source of supply in MIL-HDBK-103 (see 6.6.2 herein). The certificate of compliance submitted to DLA Land and Maritime-VA prior to listing as an approved source of supply for this drawing shall affirm that the manufacturer's product meets, for device classes Q and V, the requirements of MIL-PRF-38535 and herein or for device class M, the requirements of MIL-PRF-38535, appendix A and herein.

3.7 Certificate of conformance. A certificate of conformance as required for device classes Q and V in MIL-PRF-38535 or for device class M in MIL-PRF-38535, appendix A shall be provided with each lot of microcircuits delivered to this drawing.

3.8 Notification of change for device class M. For device class M, notification to DLA Land and Maritime-VA of change of product (see 6.2 herein) involving devices acquired to this drawing is required for any change that affects this drawing.

3.9 Verification and review for device class M. For device class M, DLA Land and Maritime, DLA Land and Maritime 's agent, and the acquiring activity retain the option to review the manufacturer's facility and applicable required documentation. Offshore documentation shall be made available onshore at the option of the reviewer.

3.10 Microcircuit group assignment for device class M. Device class M devices covered by this drawing shall be in microcircuit group number 59 (see MIL-PRF-38535, appendix A).

<b>STANDARD MICROCIRCUIT DRAWING</b> DLA LAND AND MARITIME COLUMBUS, OHIO 43218-3990	SIZE <b>A</b>		<b>85514</b>
		REVISION LEVEL <b>L</b>	SHEET <b>6</b>

Device types	01,02,03,04	01,05	01,02,03,04
Case outlines	G and P	H	2
Terminal number	Terminal symbol		
1	NC	NC	NC
2	VIN	VIN	NC
3	TEMP	TEMP	NC
4	GND	GND	NC
5	TRIM	TRIM	VIN
6	VOUT	VOUT	NC
7	NC	NC	TEMP
8	NC	NC	NC
9	---	NC	NC
10	---	NC	GND
11	---	---	NC
12	---	---	TRIM
13	---	---	NC
14	---	---	NC
15	---	---	VOUT
16	---	---	NC
17	---	---	NC
18	---	---	NC
19	---	---	NC
20	---	---	NC

NC = No connection

FIGURE 1. Terminal connections.

<b>STANDARD MICROCIRCUIT DRAWING</b> DLA LAND AND MARITIME COLUMBUS, OHIO 43218-3990	SIZE <b>A</b>		<b>85514</b>
		REVISION LEVEL <b>L</b>	SHEET <b>7</b>

4. VERIFICATION

4.1 Sampling and inspection. For device classes Q and V, sampling and inspection procedures shall be in accordance with MIL-PRF-38535 or as modified in the device manufacturer's Quality Management (QM) plan. The modification in the QM plan shall not affect the form, fit, or function as described herein. For device class M, sampling and inspection procedures shall be in accordance with MIL-PRF-38535, appendix A.

4.2 Screening. For device classes Q and V, screening shall be in accordance with MIL-PRF-38535, and shall be conducted on all devices prior to qualification and technology conformance inspection. For device class M, screening shall be in accordance with method 5004 of MIL-STD-883, and shall be conducted on all devices prior to quality conformance inspection.

4.2.1 Additional criteria for device class M.

- a. Burn-in test, method 1015 of MIL-STD-883.
  - (1) Test condition B or D. The test circuit shall be maintained by the manufacturer under document revision level control and shall be made available to the preparing or acquiring activity upon request. The test circuit shall specify the inputs, outputs, biases, and power dissipation, as applicable, in accordance with the intent specified in method 1015.
  - (2) TA = +125°C, minimum.
- b. Interim and final electrical test parameters shall be as specified in table IIA herein.

4.2.2 Additional criteria for device classes Q and V.

- a. The burn-in test duration, test condition and test temperature, or approved alternatives shall be as specified in the device manufacturer's QM plan in accordance with MIL-PRF-38535. The burn-in test circuit shall be maintained under document revision level control of the device manufacturer's Technology Review Board (TRB) in accordance with MIL-PRF-38535 and shall be made available to the acquiring or preparing activity upon request. The test circuit shall specify the inputs, outputs, biases, and power dissipation, as applicable, in accordance with the intent specified in method 1015 of MIL-STD-883.
- b. Interim and final electrical test parameters shall be as specified in table IIA herein.
- c. Additional screening for device class V beyond the requirements of device class Q shall be as specified in MIL-PRF-38535, appendix B.

4.3 Qualification inspection for device classes Q and V. Qualification inspection for device classes Q and V shall be in accordance with MIL-PRF-38535. Inspections to be performed shall be those specified in MIL-PRF-38535 and herein for groups A, B, C, D, and E inspections (see 4.4.1 through 4.4.4).

4.4 Conformance inspection. Technology conformance inspection for classes Q and V shall be in accordance with MIL-PRF-38535 including groups A, B, C, D, and E inspections and as specified. Quality conformance inspection for device class M shall be in accordance with MIL-PRF-38535, appendix A and as specified herein. Inspections to be performed for device class M shall be those specified in method 5005 of MIL-STD-883 and herein for groups A, B, C, D, and E inspections (see 4.4.1 through 4.4.4).

4.4.1 Group A inspection.

- a. Tests shall be as specified in table IIA herein.
- b. Subgroups 5, 6, 7, 9, 10, and 11 in table I, method 5005 of MIL-STD-883 shall be omitted.

<b>STANDARD MICROCIRCUIT DRAWING</b> DLA LAND AND MARITIME COLUMBUS, OHIO 43218-3990	SIZE <b>A</b>		<b>85514</b>
		REVISION LEVEL <b>L</b>	SHEET <b>8</b>



TABLE IIA. Electrical test requirements.

Test requirements	Subgroups (in accordance with MIL-STD-883, method 5005, table I)	Subgroups (in accordance with MIL-PRF-38535, table III)	
	Device class M	Device class Q	Device class V
Interim electrical parameters (see 4.2)	---	---	---
Final electrical parameters (see 4.2)	1,2,3,4 <u>1/</u>	1,2,3,4 <u>1/</u>	1,2,3,4 <u>1/ 2/</u>
Group A test requirements (see 4.4)	1,2,3,8	1,2,3,8	1,2,3,8
Group C end-point electrical parameters (see 4.4)	1,2,3	1,2,3	1,2,3 <u>2/</u>
Group D end-point electrical parameters (see 4.4)	1,2,3	1,2,3	1,2,3
Group E end-point electrical parameters (see 4.4)	---	---	1

1/ PDA applies to subgroup 1.

2/ Delta limits as specified in table IIB shall be required where specified, and the delta limits shall be computed with reference to the previous interim electrical parameters.

TABLE IIB. 240 hour and 1000 hour life test deltas.

Test	Symbol	End points		Delta
		Min	Max	
Output voltage	V <sub>O</sub>	4.985 V	5.015 V	±3 mV

4.4.2 Group C inspection. The group C inspection end-point electrical parameters shall be as specified in table IIA herein.

4.4.2.1 Additional criteria for device class M. Steady-state life test conditions, method 1005 of MIL-STD-883:

- a. Test condition B or D. The test circuit shall be maintained by the manufacturer under document revision level control and shall be made available to the preparing or acquiring activity upon request. The test circuit shall specify the inputs, outputs, biases, and power dissipation, as applicable, in accordance with the intent specified in method 1005 of MIL-STD-883.
- b. T<sub>A</sub> = +125°C, minimum.
- c. Test duration: 1,000 hours, except as permitted by method 1005 of MIL-STD-883.

4.4.2.1 Additional criteria for device classes Q and V. The steady-state life test duration, test condition and test temperature, or approved alternatives shall be as specified in the device manufacturer's QM plan in accordance with MIL-PRF-38535. The test circuit shall be maintained under document revision level control by the device manufacturer's TRB in accordance with MIL-PRF-38535 and shall be made available to the acquiring or preparing activity upon request. The test circuit shall specify the inputs, outputs, biases, and power dissipation, as applicable, in accordance with the intent specified in method 1005 of MIL-STD-883.

<b>STANDARD MICROCIRCUIT DRAWING</b> DLA LAND AND MARITIME COLUMBUS, OHIO 43218-3990	SIZE <b>A</b>		<b>85514</b>
		REVISION LEVEL <b>L</b>	SHEET <b>9</b>

4.4.3 Group D inspection. The group D inspection end-point electrical parameters shall be as specified in table IIA herein.

4.4.4 Group E inspection. Group E inspection is required only for parts intended to be marked as radiation hardness assured (see 3.5 herein).

- a. End-point electrical parameters shall be as specified in table IIA herein.
- b. For device classes Q and V, the devices or test vehicle shall be subjected to radiation hardness assured tests as specified in MIL-PRF-38535 for the RHA level being tested. For device class M, the devices shall be subjected to radiation hardness assured tests as specified in MIL-PRF-38535, appendix A for the RHA level being tested. All device classes must meet the postirradiation end-point electrical parameter limits as defined in table I at TA = +25°C ±5°C, after exposure, to the subgroups specified in table IIA herein.

4.4.4.1 Total dose irradiation testing. Total dose irradiation testing shall be performed in accordance with MIL-STD-883 method 1019, condition A for device type 01, condition D for device type 05 and as specified herein.

## 5. PACKAGING

5.1 Packaging requirements. The requirements for packaging shall be in accordance with MIL-PRF-38535 for device classes Q and V or MIL-PRF-38535, appendix A for device class M.

## 6. NOTES

6.1 Intended use. Microcircuits conforming to this drawing are intended for use for Government microcircuit applications (original equipment), design applications, and logistics purposes.

6.1.1 Replaceability. Microcircuits covered by this drawing will replace the same generic device covered by a contractor-prepared specification or drawing.

6.2 Configuration control of SMD's. All proposed changes to existing SMD's will be coordinated with the users of record for the individual documents. This coordination will be accomplished using DD Form 1692, Engineering Change Proposal.

6.3 Record of users. Military and industrial users should inform DLA Land and Maritime when a system application requires configuration control and which SMD's are applicable to that system. DLA Land and Maritime will maintain a record of users and this list will be used for coordination and distribution of changes to the drawings. Users of drawings covering microelectronic devices (FSC 5962) should contact DLA Land and Maritime-VA, telephone (614) 692-8108.

6.4 Comments. Comments on this drawing should be directed to DLA Land and Maritime-VA, Columbus, Ohio 43218-3990, or telephone (614) 692-0540.

6.5 Abbreviations, symbols, and definitions. The abbreviations, symbols, and definitions used herein are defined in MIL-PRF-38535 and MIL-HDBK-1331.

6.6 Sources of supply.

6.6.1 Sources of supply for device classes Q and V. Sources of supply for device classes Q and V are listed in MIL-HDBK-103 and QML-38535. The vendors listed in QML-38535 have submitted a certificate of compliance (see 3.6 herein) to DLA Land and Maritime-VA and have agreed to this drawing.

6.6.2 Approved sources of supply for device class M. Approved sources of supply for class M are listed in MIL-HDBK-103. The vendors listed in MIL-HDBK-103 have agreed to this drawing and a certificate of compliance (see 3.6 herein) has been submitted to and accepted by DLA Land and Maritime-VA.

<b>STANDARD MICROCIRCUIT DRAWING</b> DLA LAND AND MARITIME COLUMBUS, OHIO 43218-3990	SIZE <b>A</b>		<b>85514</b>
		REVISION LEVEL <b>L</b>	SHEET <b>10</b>

6.7 Application notes.

6.7.1 Normal configuration. No external components required.

6.7.2 External trim configuration. The device trim terminal can be used to adjust the output voltage over a  $5\text{ V} \pm 300\text{ mV}$  range. This feature allows the system designer to trim system errors by setting the reference to a voltage other than 5 V. The output can also be set to exactly 5.000 V or to 5.12 V for binary applications.

Adjustment of the output does not significantly affect the temperature performance of the device. Normally, the temperature coefficient change is 0.7 ppm/°C for 100 mV of output adjustment. See figure 2.

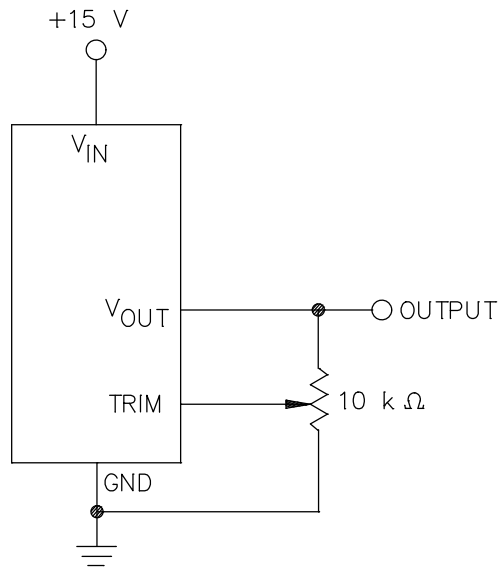

FIGURE 2.  $V_{OUT}$  trim circuit.

**STANDARD  
MICROCIRCUIT DRAWING**  
DLA LAND AND MARITIME  
COLUMBUS, OHIO 43218-3990

SIZE  
**A**

**85514**

REVISION LEVEL  
**L**

SHEET  
**11**

STANDARD MICROCIRCUIT DRAWING BULLETIN

DATE: 17-05-02

Approved sources of supply for SMD 85514 are listed below for immediate acquisition information only and shall be added to MIL-HDBK-103 and QML-38535 during the next revision. MIL-HDBK-103 and QML-38535 will be revised to include the addition or deletion of sources. The vendors listed below have agreed to this drawing and a certificate of compliance has been submitted to and accepted by DLA Land and Maritime-VA. This information bulletin is superseded by the next dated revision of MIL-HDBK-103 and QML-38535. DLA Land and Maritime maintains an online database of all current sources of supply at <https://landandmaritimeapps.dla.mil/Programs/Smcr/>.

Standard microcircuit drawing PIN <u>1/</u>	Vendor CAGE number	Vendor similar PIN <u>2/</u>
8551401GA	<u>3/</u>	REF02AJ/883
	<u>3/</u>	REF-02AH/883
8551401GC	<u>3/</u>	REF02AJ/883B
8551401PA	24355 (2)	REF-02AZ/883
	<u>3/</u>	REF-02AJ8/883
	<u>3/</u>	REF02AZ/883B
85514012A	24355 (2)	REF-02ARC/883
8551402GC	<u>3/</u>	REF02J/883B
8551402PA	<u>3/</u>	REF02Z/883B
85514022C	<u>3/</u>	REF02RC/883B
5962-8551401VGA	<u>3/</u>	REF02AJ/QMLV
5962-8551401VHA	<u>3/</u>	REF02AL/QMLV
5962-8551401VPA	<u>3/</u>	REF02AZ/QMLV
5962-8551401V2A	<u>3/</u>	REF02ARC/QMLV
5962R8551401VGA	24355 (4)	REF02AJ/QMLR
5962R8551401VHA	24355 (4)	REF02AL/QMLR
5962R8551401VPA	24355 (4)	REF02AZ/QMLR
5962R8551401V2A	24355 (4)	REF02ARC/QMLR
8551403GC	<u>3/</u>	REF02AJ/883B
8551403PA	<u>3/</u>	REF02AZ/883B

STANDARD MICROCIRCUIT DRAWING BULLETIN – CONTINUED.

DATE: 17-05-02

Standard microcircuit drawing PIN <u>1/</u>	Vendor CAGE number	Vendor similar PIN <u>2/</u>
8551404GC	<u>3/</u>	REF02J/883B
8551404PA	<u>3/</u>	REF02Z/883B
85514042C	<u>3/</u>	REF02RC/883B
5962L8551405VHA	24355 (4)	REF02AL/QMLL

- 1/ The lead finish shown for each PIN representing a hermetic package is the most readily available from the manufacturer listed for that part. If the desired lead finish is not listed contact the vendor to determine its availability.
- 2/ Caution. Do not use this number for item acquisition. Items acquired to this number may not satisfy the performance requirements of this drawing.
- 3/ Not available from an approved source of supply.

Vendor CAGE number

Vendor name and address

24355

Analog Devices (2)  
 RT 1 Industrial Park  
 PO Box 9106  
 Norwood, MA 02062  
 Point of contact: 804 Woburn Street  
 Wilmington, MA 01887-3462

24355

Analog Devices (4)  
 RT 1 Industrial Park  
 PO Box 9106  
 Norwood, MA 02062  
 Point of contact: 7910 Triad Center Drive  
 Greensboro, NC 27409-9605

The information contained herein is disseminated for convenience only and the Government assumes no liability whatsoever for any inaccuracies in the information bulletin.