

REVISIONS

LTR	DESCRIPTION	DATE (YR-MO-DA)	APPROVED
A	Convert to military drawing format. Add vendor CAGE 01295. Add cases F and 2. Change V _{IL} . Change disable times.	86-08-22	M. A. Frye
B	Split V _{IL} into temperatures. Add figure 4. Change I _{IL} and propagation delay times. Add minimum propagation delay times. Add footnotes to table I. Editorial changes throughout. Add V _{OH} test at I _{OH} = -0.4 mA. Change in test conditions for I _{IL} and I _{IH} . Add functional testing to Table I. Change in test conditions for propagation delay times. Change in Table II. Add CAGE 18324.	88-05-12	M. A. Frye
C	Changes IAW NOR 5962-R087-92. - pn	92-07-07	Monica L. Poelking
D	Changes IAW NOR 5962-R046-96. - ltg	96-01-25	Monica L. Poelking
E	Update to reflect latest changes in format and requirements. Editorial changes throughout. - les	01-12-06	Raymond Monnin
F	Change 3.5 marking paragraph to remove "5962-". Update boilerplate to MIL-PRF-38535 requirements. - CFS	05-08-17	Thomas M. Hess
G	Update drawing to current MIL-PRF-38535 requirements. - jt	15-02-10	C. SAFFLE
H	Update drawing to latest MIL-PRF-38535 requirements. - jt	19-11-04	J. Eschmeyer



CURRENT CAGE CODE 67268

THE ORIGINAL FIRST PAGE OF THIS DRAWING HAS BEEN REPLACED

REV																				
SHEET																				
REV																				
SHEET																				
REV STATUS	REV	H	H	H	H	H	H	H	H	H	H	H	H	H	H					
OF SHEETS	SHEET	1	2	3	4	5	6	7	8	9	10	11	12							
PMIC N/A	PREPARED BY Monica L. Poelking	<p align="center">DLA LAND AND MARITIME COLUMBUS, OHIO 43218-3990 https://www.dla.mil/LandandMaritime</p> <p>MICROCIRCUIT, DIGITAL, BIPOLAR, ADVANCED LOW-POWER SCHOTTKY, TTL, MULTIPLEXERS, MONOLITHIC SILICON</p>																		
<p align="center">STANDARD MICROCIRCUIT DRAWING</p> <p>THIS DRAWING IS AVAILABLE FOR USE BY ALL DEPARTMENTS AND AGENCIES OF THE DEPARTMENT OF DEFENSE</p>	CHECKED BY Ray Monnin																			
	APPROVED BY Michael A. Frye																			
	DRAWING APPROVAL DATE 86-02-20																			
AMSC N/A	REVISION LEVEL H	SIZE A	CAGE CODE 14933	85097																
		SHEET		1 OF 12																

1. SCOPE

1.1 Scope. This drawing describes device requirements for MIL-STD-883 compliant, non-JAN class level B microcircuits in accordance with MIL-PRF-38535, appendix A.

1.2 Part or Identifying Number (PIN). The complete PIN is as shown in the following example:

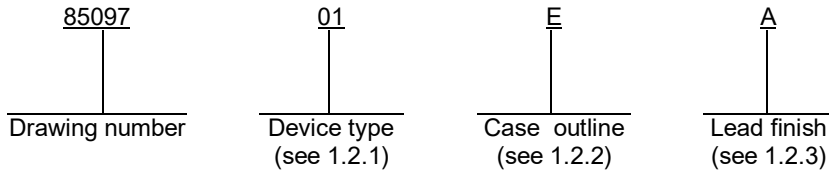

1.2.1 Device type. The device type identify the circuit function as follows:

<u>Device type</u>	<u>Generic number</u>	<u>Circuit function</u>
01	54ALS257	Quad 1-of-8 data selector/multiplexer with 3-state outputs

1.2.2 Case outlines. The case outlines are as designated in MIL-STD-1835 and as follows:

<u>Outline letter</u>	<u>Descriptive designator</u>	<u>Terminals</u>	<u>Package style</u>
E	GDIP1-T16 or GDIP2-T16	16	Dual-in-line
F	GDFP2-F16 or GDFP3-F16	16	Flat pack
2	CQCC1-N20	20	Square chip carrier

1.2.3 Lead finish. The lead finish is as specified in MIL-PRF-38535, appendix A.

1.3 Absolute maximum ratings.

Supply voltage	-0.5 V dc minimum to +7.0 V dc maximum
Input voltage range	-1.5 V dc at -18 mA to +7.0 V dc
Voltage applied to a disabled 3-state output	5.5 V dc
Storage temperature range	-65°C to +150°C
Maximum power dissipation (P _D) per device ^{1/}	77 mW
Lead temperature (soldering, 10 seconds)	+300°C
Thermal resistance, junction-to-case (θ _{JC})	See MIL-STD-1835
Junction temperature (T _J)	+175°C

1.4 Recommended operating conditions.

Supply voltage range (V _{CC})	+4.5 V dc minimum to +5.5 V dc maximum
Minimum high level input voltage (V _{IH})	2.0 V dc
Maximum low level input voltage (V _{IL}):	
V _{IL} = +125°C	0.7 V dc
V _{IL} = +25°C	0.8 V dc
V _{IL} = -55°C	0.8 V dc
Case operating temperature range (T _C)	-55°C to +125°C

^{1/} Maximum power dissipation is defined as V_{CC} x I_{CC}, and must withstand the added P_D due to short circuit test (e.g. I_{OS}).

STANDARD MICROCIRCUIT DRAWING DLA LAND AND MARITIME COLUMBUS, OHIO 43218-3990	SIZE A		85097
		REVISION LEVEL H	SHEET 2

2. APPLICABLE DOCUMENTS

2.1 Government specification, standards, and handbooks. The following specification, standards, and handbooks form a part of this drawing to the extent specified herein. Unless otherwise specified, the issues of these documents are those cited in the solicitation or contract.

DEPARTMENT OF DEFENSE SPECIFICATION

MIL-PRF-38535 - Integrated Circuits, Manufacturing, General Specification for.

DEPARTMENT OF DEFENSE STANDARDS

MIL-STD-883 - Test Method Standard Microcircuits.
MIL-STD-1835 - Interface Standard Electronic Component Case Outlines.

DEPARTMENT OF DEFENSE HANDBOOKS

MIL-HDBK-103 - List of Standard Microcircuit Drawings.
MIL-HDBK-780 - Standard Microcircuit Drawings.

(Copies of these documents are available online at <https://quicksearch.dla.mil/>)

2.2 Order of precedence. In the event of a conflict between the text of this drawing and the references cited herein, the text of this drawing takes precedence. Nothing in this document, however, supersedes applicable laws and regulations unless a specific exemption has been obtained.

3. REQUIREMENTS

3.1 Item requirements. The individual item requirements shall be in accordance with MIL-PRF-38535, appendix A for non-JAN class level B devices and as specified herein. Product built to this drawing that is produced by a Qualified Manufacturer Listing (QML) certified and qualified manufacturer or a manufacturer who has been granted transitional certification to MIL-PRF-38535 may be processed as QML product in accordance with the manufacturers approved program plan and qualifying activity approval in accordance with MIL-PRF-38535. This QML flow as documented in the Quality Management (QM) plan may make modifications to the requirements herein. These modifications shall not affect form, fit, or function of the device. These modifications shall not affect the PIN as described herein. A "Q" or "QML" certification mark in accordance with MIL-PRF-38535 is required to identify when the QML flow option is used.

3.2 Design, construction, and physical dimensions. The design, construction, and physical dimensions shall be as specified in MIL-PRF-38535, appendix A and herein.

3.2.1 Case outlines. The case outlines shall be in accordance with 1.2.2 herein.

3.2.2 Terminal connections. The terminal connections shall be as specified on figure 1.

3.2.3 Truth table. The truth table shall be as specified on figure 2.

3.2.4 Logic diagram. The logic diagram shall be as specified on figure 3.

3.2.5 Test circuits and switching waveforms. The test circuits and switching waveforms shall be as specified on figure 4.

STANDARD MICROCIRCUIT DRAWING DLA LAND AND MARITIME COLUMBUS, OHIO 43218-3990	SIZE A		85097
		REVISION LEVEL H	SHEET 3

3.3 Electrical performance characteristics. Unless otherwise specified herein, the electrical performance characteristics are as specified in table I and shall apply over the full case operating temperature range.

3.4 Electrical test requirements. The electrical test requirements shall be the subgroups specified in table II. The electrical tests for each subgroup are described in table I.

3.5 Marking. Marking shall be in accordance with MIL-PRF-38535, appendix A. The part shall be marked with the PIN listed in 1.2 herein. In addition, the manufacturer's PIN may also be marked.

3.5.1 Certification/compliance mark. A compliance indicator "C" shall be marked on all non-JAN devices built in compliance to MIL-PRF-38535, appendix A. The compliance indicator "C" shall be replaced with a "Q" or "QML" certification mark in accordance with MIL-PRF-38535 to identify when the QML flow option is used.

3.6 Certificate of compliance. A certificate of compliance shall be required from a manufacturer in order to be listed as an approved source of supply in MIL-HDBK-103 (see 6.6 herein). The certificate of compliance submitted to DLA Land and Maritime -VA prior to listing as an approved source of supply shall affirm that the manufacturer's product meets the requirements of MIL-PRF-38535, appendix A and the requirements herein.

3.7 Certificate of conformance. A certificate of conformance as required in MIL-PRF-38535, appendix A shall be provided with each lot of microcircuits delivered to this drawing.

3.8 Notification of change. Notification of change to DLA Land and Maritime -VA shall be required for any change that affects this drawing.

3.9 Verification and review. DLA Land and Maritime, DLA Land and Maritime's agent, and the acquiring activity retain the option to review the manufacturer's facility and applicable required documentation. Offshore documentation shall be made available onshore at the option of the reviewer.

STANDARD MICROCIRCUIT DRAWING DLA LAND AND MARITIME COLUMBUS, OHIO 43218-3990	SIZE A		85097
		REVISION LEVEL H	SHEET 4

TABLE I. Electrical performance characteristics.

Test	Symbol	Conditions <u>1/</u> -55°C ≤ T _C ≤ +125°C unless otherwise specified		Group A subgroups	Device type	Limits		Unit
						Min	Max	
High level output voltage	V _{OH}	V _{CC} = 4.5 V, V _{IH} = 2.0 V, V _{IL} : <u>2/</u> @+125°C = 0.7 V @+25°C = 0.8 V @-55°C = 0.8 V	I _{OH} = -0.4 mA	1, 2, 3	All	2.5		V
			I _{OH} = -1.0 mA	1, 2, 3	All	2.4		V
Low level output voltage	V _{OL}	I _{OL} = 12 mA, V _{CC} = 4.5 V, V _{IH} = 2.0 V <u>2/</u>	V _{IL} = 0.7 V	2	All		0.4	V
			V _{IL} = 0.8 V	1, 3	All		0.4	V
Input clamp voltage	V _{IC}	V _{CC} = 4.5 V, I _{IH} = -18 mA		1, 2, 3	All		-1.5	V
Low level input current	I _{IL}	V _{CC} = 5.5 V, V _{IN} = 0.4 V, Unused inputs ≥ 4.5 V		1, 2, 3	All		-0.1	mA
High level input current	I _{IH1}	V _{CC} = 5.5 V, V _{IN} = 2.7 V, Unused inputs = 0.0 V		1, 2, 3	All		20	μA
	I _{IH2}	V _{CC} = 5.5 V, V _{IN} = 7.0 V, Unused inputs = 0.0 V		1, 2, 3	All		100	μA
Output current	I _O	V _{CC} = 5.5 V, V _{OUT} = 2.25 V <u>3/</u>		1, 2, 3	All	-20	-112	mA
Supply current	I _{CCCH}	V _{CC} = 5.5 V		1, 2, 3	All		8	mA
	I _{CCCL}			1, 2, 3	All		12	
	I _{CCZ}			1, 2, 3	All		14	
Off-state output current	I _{OZH}	V _{CC} = 5.5 V, V _{OUT} = 2.7 V		1, 2, 3	All		20	μA
	I _{OZL}	V _{CC} = 5.5 V, V _{OUT} = 0.4 V		1, 2, 3	All		-20	μA
Functional tests		See 4.3.1c <u>4/</u>		7, 8	All			

See footnotes at end of table.

**STANDARD
MICROCIRCUIT DRAWING**
DLA LAND AND MARITIME
COLUMBUS, OHIO 43218-3990

SIZE
A

85097

REVISION LEVEL
H

SHEET
5

TABLE I. Electrical performance characteristics - Continued.

Test	Symbol	Conditions ^{1/} -55°C ≤ T _C ≤ +125°C unless otherwise specified	Group A subgroups	Device type	Limits		Unit
					Min	Max	
Propagation delay time, A, B to Y	t _{PLH1}	V _{CC} = 4.5 V to 5.5 V, C _L = 50 pF, R ₁ = 500Ω, R ₂ = 500Ω ^{5/}	9, 10, 11	All	2	12	ns
	t _{PHL1}		9, 10, 11	All	2	13	ns
Propagation delay time, \bar{A} /B to any Y	t _{PLH2}	See figure 4	9, 10, 11	All	4	21	ns
	t _{PHL2}		9, 10, 11	All	6	25	ns
Output enable time, \bar{G} to any Y	t _{PZH}		9, 10, 11	All	3	16	ns
	t _{PZL}		9, 10, 11	All	4	18	ns
Output disable time, \bar{G} to any Y	t _{PHZ}		9, 10, 11	All	2	10	ns
	t _{PLZ}		9, 10, 11	All	2	25	ns

- ^{1/} Unused inputs that do not directly control the pin under test must be put ≥ 2.5 V or ≤ 0.4 V. The inputs shall not exceed 5.5 V or go less than 0.0 V. No inputs shall be floated.
- ^{2/} All outputs must be tested. In the case where only one input at V_{IL} maximum or V_{IH} minimum produces the proper output state, the test must be performed with each input being selected as the V_{IL} maximum or the V_{IH} minimum input.
- ^{3/} The output conditions have been chosen to produce a current that closely approximates one half of the true short circuit output current, I_{OS}. Not more than one output will be tested at one time and the duration of the test condition shall not exceed 1 second.
- ^{4/} Functional tests shall be conducted at input test conditions of GND ≤ V_{IL} ≤ V_{OL} and V_{OH} ≤ V_{IH} ≤ V_{CC}.
- ^{5/} Propagation delay limits are based on single output switching. Unused outputs = 3.5 V or ≤ 0.3 V.

**STANDARD
MICROCIRCUIT DRAWING**
DLA LAND AND MARITIME
COLUMBUS, OHIO 43218-3990

SIZE
A

85097

REVISION LEVEL
H

SHEET
6

Device types	01	01
Case outlines	E, F	2
Terminal number	Terminal symbols	
1	\bar{A}/B	NC
2	1A	\bar{A}/B
3	1B	1A
4	1Y	1B
5	2A	1Y
6	2B	NC
7	2Y	2A
8	GND	2B
9	3Y	2Y
10	3B	GND
11	3A	NC
12	4Y	3Y
13	4B	3B
14	4A	3A
15	\bar{G}	4Y
16	V _{CC}	NC
17	---	4B
18	---	4A
19	---	\bar{G}
20	---	V _{CC}

FIGURE 1. Terminal connections.

Output control	Inputs			Output Y
	Select \bar{A}/B	Data		
		A	B	
\bar{G}				
H	X	X	X	Z
L	L	L	X	L
L	L	H	X	H
L	H	X	L	L
L	H	X	H	H

H = High voltage level
L = Low voltage level
Z = High impedance
X = Irrelevant

FIGURE 2. Truth table.

**STANDARD
MICROCIRCUIT DRAWING**
DLA LAND AND MARITIME
COLUMBUS, OHIO 43218-3990

SIZE
A

85097

REVISION LEVEL
H

SHEET
7

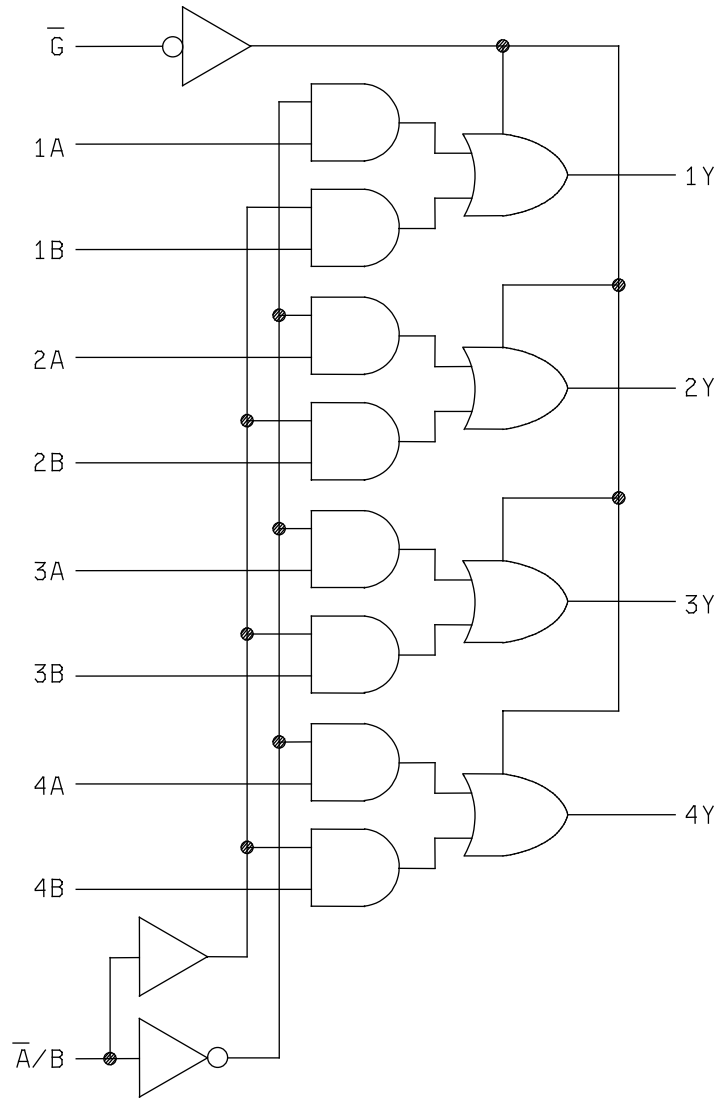

FIGURE 3. Logic diagram.

**STANDARD
MICROCIRCUIT DRAWING**
DLA LAND AND MARITIME
COLUMBUS, OHIO 43218-3990

SIZE
A

85097

REVISION LEVEL
H

SHEET
8

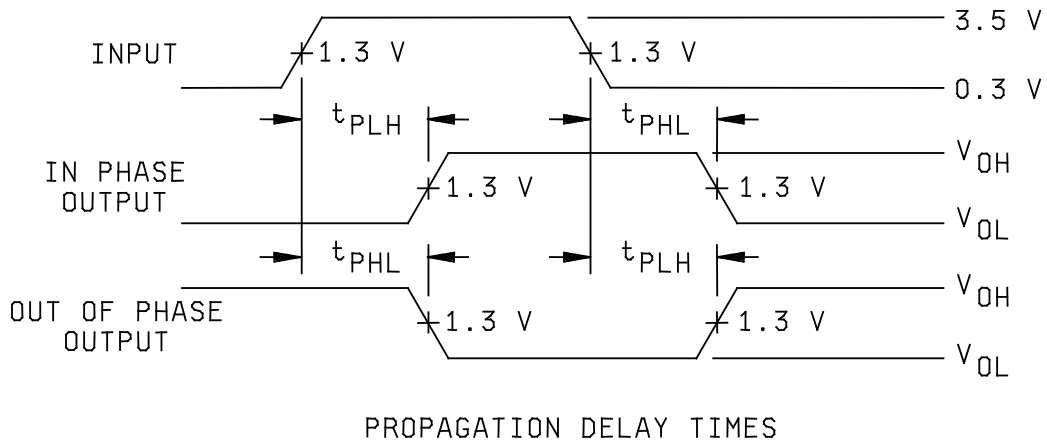
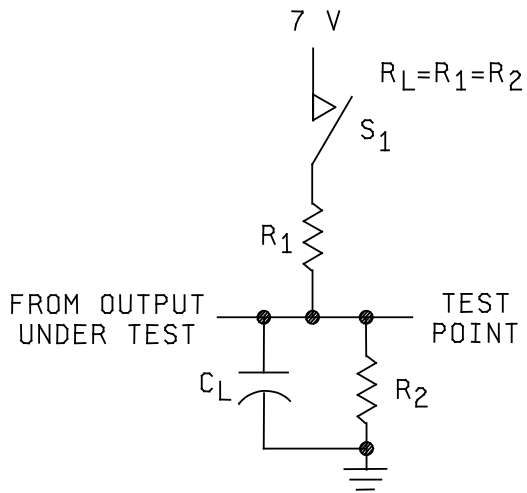

FIGURE 4. Test circuit and switching waveforms.

**STANDARD
MICROCIRCUIT DRAWING**
DLA LAND AND MARITIME
COLUMBUS, OHIO 43218-3990

SIZE
A

85097

REVISION LEVEL
H

SHEET
9

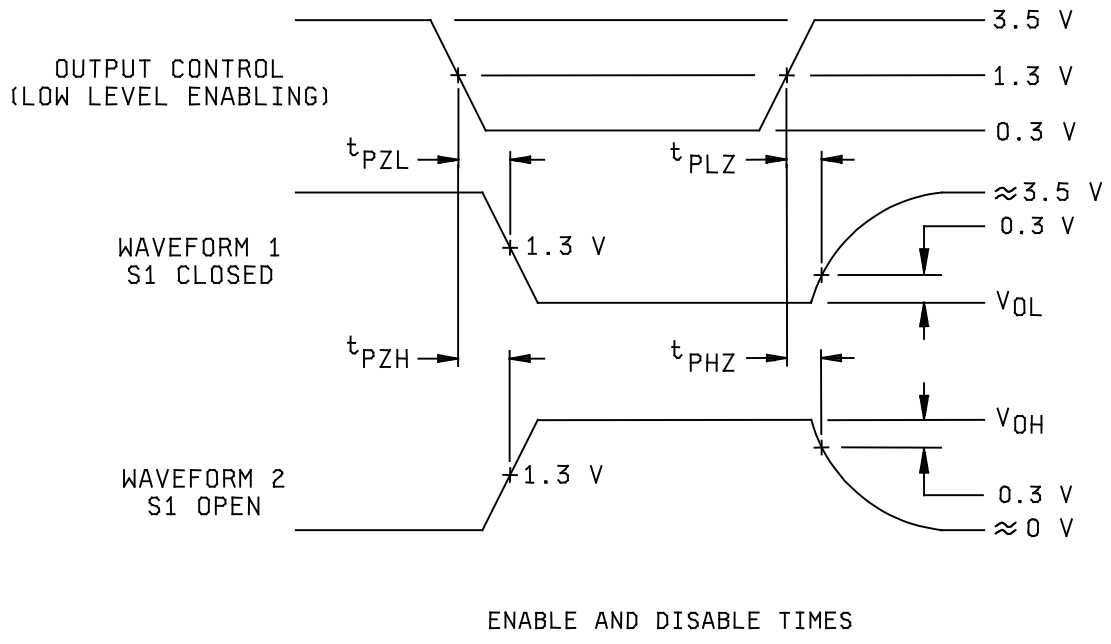

- NOTES:
1. C_L includes probe and jig capacitance.
 2. All input pulses have the following characteristics: $PRR \leq 10$ MHz, duty cycle = 50 percent, $t_r = t_f = 3$ ns ± 1 ns.
 3. The outputs are measured one at a time with one input transition per measurement.
 4. Waveform 1 is for an output with internal conditions such that the output is low except when disabled by the output control.
Waveform 2 is for an output with internal conditions such that the output is high except when disabled by the output control.
 5. When measuring propagation delay times of three-state outputs, switch S1 is open.

FIGURE 4. Test circuit and switching waveforms - Continued.

STANDARD MICROCIRCUIT DRAWING DLA LAND AND MARITIME COLUMBUS, OHIO 43218-3990	SIZE A	85097
	REVISION LEVEL H	SHEET 10

4. VERIFICATION

4.1 Sampling and inspection. Sampling and inspection procedures shall be in accordance with MIL-PRF-38535, appendix A.

4.2 Screening. Screening shall be in accordance with method 5004 of MIL-STD-883, and shall be conducted on all devices prior to quality conformance inspection. The following additional criteria shall apply:

a. Burn-in test, method 1015 of MIL-STD-883.

(1) Test condition A or D. The test circuit shall be maintained by the manufacturer under document revision level control and shall be made available to the preparing or acquiring activity upon request. The test circuit shall specify the inputs, outputs, biases, and power dissipation, as applicable, in accordance with the intent specified in method 1015 of MIL-STD-883.

(2) T_A = +125°C, minimum.

b. Interim and final electrical test parameters shall be as specified in table II herein, except interim electrical parameter tests prior to burn-in are optional at the discretion of the manufacturer.

TABLE II. Electrical test requirements.

MIL-STD-883 test requirements	Subgroups (in accordance with MIL-STD-883, method 5005, table I)
Interim electrical parameters (method 5004)	---
Final electrical test parameters (method 5004)	1*, 2, 3, 7, 8, 9, 10, 11
Group A test requirements (method 5005)	1, 2, 3, 7, 8, 9, 10, 11
Groups C and D end-point electrical parameters (method 5005)	1, 2, 3

* PDA applies to subgroup 1.

4.3 Quality conformance inspection. Quality conformance inspection shall be in accordance with method 5005 of MIL-STD-883 including groups A, B, C, and D inspections. The following additional criteria shall apply.

4.3.1 Group A inspection.

a. Tests shall be as specified in table II herein.

b. Subgroups 4, 5 and 6 in table I, method 5005 of MIL-STD-883 shall be omitted.

c. Subgroups 7 and 8 shall include verification of the truth table.

STANDARD MICROCIRCUIT DRAWING DLA LAND AND MARITIME COLUMBUS, OHIO 43218-3990	SIZE A		85097
		REVISION LEVEL H	SHEET 11

4.3.2 Groups C and D inspections.

- a. End-point electrical parameters shall be as specified in table II herein.
- b. Steady-state life test conditions, method 1005 of MIL-STD-883.
 - (1) Test condition A or D. The test circuit shall be maintained by the manufacturer under document revision level control and shall be made available to the preparing or acquiring activity upon request. The test circuit shall specify the inputs, outputs, biases, and power dissipation, as applicable, in accordance with the intent specified in method 1005 of MIL-STD-883.
 - (2) $T_A = +125^{\circ}\text{C}$, minimum.
 - (3) Test duration: 1,000 hours, except as permitted by method 1005 of MIL-STD-883.

5. PACKAGING

5.1 Packaging requirements. The requirements for packaging shall be in accordance with MIL-PRF-38535, appendix A.

6. NOTES

6.1 Intended use. Microcircuits conforming to this drawing are intended for use for Government microcircuit applications (original equipment), design applications, and logistics purposes.

6.2 Replaceability. Microcircuits covered by this drawing will replace the same generic device covered by a contractor-prepared specification or drawing.

6.3 Configuration control of SMD's. All proposed changes to existing SMD's will be coordinated with the users of record for the individual documents. This coordination will be accomplished using DD Form 1692, Engineering Change Proposal.

6.4 Record of users. Military and industrial users shall inform DLA Land and Maritime when a system application requires configuration control and the applicable SMD to that system. DLA Land and Maritime will maintain a record of users and this list will be used for coordination and distribution of changes to the drawings. Users of drawings covering microelectronics devices (FSC 5962) should contact DLA Land and Maritime -VA, telephone (614) 692-8108.

6.5 Comments. Comments on this drawing should be directed to DLA Land and Maritime -VA, Columbus, Ohio 43218-3990, or telephone (614) 692-0540.

6.6 Approved sources of supply. Approved sources of supply are listed in MIL-HDBK-103 and QML-38535. The vendors listed in MIL-HDBK-103 and QML-38535 have agreed to this drawing and a certificate of compliance (see 3.6 herein) has been submitted to and accepted by DLA Land and Maritime -VA.

STANDARD MICROCIRCUIT DRAWING DLA LAND AND MARITIME COLUMBUS, OHIO 43218-3990	SIZE A		85097
		REVISION LEVEL H	SHEET 12

STANDARD MICROCIRCUIT DRAWING BULLETIN

DATE: 19-11-04

Approved sources of supply for SMD 85097 are listed below for immediate acquisition information only and shall be added to MIL-HDBK-103 and QML-38535 during the next revision. MIL-HDBK-103 and QML-38535 will be revised to include the addition or deletion of sources. The vendors listed below have agreed to this drawing and a certificate of compliance has been submitted to and accepted by DLA Land and Maritime -VA. This information bulletin is superseded by the next dated revision of MIL-HDBK-103 and QML-38535. DLA Land and Maritime maintains an online database of all current sources of supply at <https://landandmaritimeapps.dla.mil/Programs/Smcr/>.

Standard microcircuit drawing PIN <u>1/</u>	Vendor CAGE number	Vendor similar PIN <u>2/</u>
8509701EA	01295 <u>3/</u> <u>3/</u>	SNJ54ALS257AJ DM54ALS257J/883B 54ALS257/BEA
8509701FA	<u>3/</u> <u>3/</u>	SNJ54ALS257AW 54ALS257/BFA
85097012A	01295 <u>3/</u>	SNJ54ALS257AFK 54ALS257/B2A

- 1/ The lead finish shown for each PIN representing a hermetic package is the most readily available from the manufacturer listed for that part. If the desired lead finish is not listed contact the vendor to determine its availability.
- 2/ Caution. Do not use this number for item acquisition. Items acquired to this number may not satisfy the performance requirements of this drawing.
- 3/ Not available from an approved source of supply.

Vendor CAGE
number

01295

Vendor name
and address

Texas Instruments, Inc.
Semiconductor Group
8505 Forest Lane
P.O. Box 660199
Dallas, TX 75243

The information contained herein is disseminated for convenience only and the Government assumes no liability whatsoever for any inaccuracies in the information bulletin.