



1. SCOPE

1.1 Scope. This drawing documents two product assurance class levels consisting of high reliability (device class Q and M) and space application (device class V). A choice of case outlines and lead finishes are available and are reflected in the Part or Identifying Number (PIN). When available, a choice of Radiation Hardness Assurance (RHA) levels is reflected in the PIN.

1.2 PIN. The PIN is as shown in the following example:

For device classes M and Q:

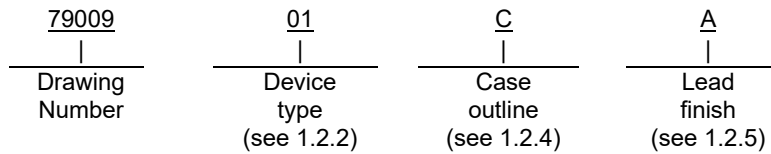

For device class V:

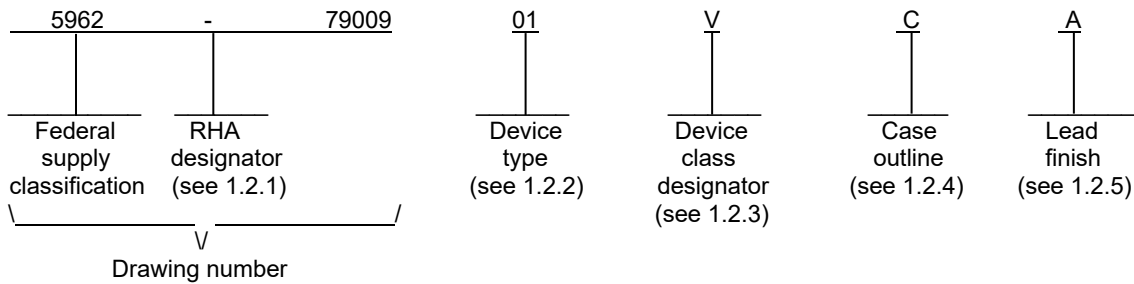

1.2.1 RHA designator. Device classes Q and V RHA marked devices meet the MIL-PRF-38535 specified RHA levels and are marked with the appropriate RHA designator. Device class M RHA marked devices meet the MIL-PRF-38535, appendix A specified RHA levels and are marked with the appropriate RHA designator. A dash (-) indicates a non-RHA device.

1.2.2 Device types. The device types identify the circuit function as follows:

<u>Device type</u>	<u>Generic number</u>	<u>Circuit function</u>
01	55183, 7830	Dual, differential line driver

1.2.3 Device class designator. The device class designator is a single letter identifying the product assurance level as follows:

<u>Device class</u>	<u>Device requirements documentation</u>
M	Vendor self-certification to the requirements for MIL-STD-883 compliant, non-JAN class level B microcircuits in accordance with MIL-PRF-38535, appendix A
Q or V	Certification and qualification to MIL-PRF-38535

<b>STANDARD MICROCIRCUIT DRAWING</b> DLA LAND AND MARITIME COLUMBUS, OHIO 43218-3990	SIZE <b>A</b>		<b>79009</b>
		REVISION LEVEL <b>K</b>	SHEET <b>2</b>

1.2.4 Case outlines. The case outlines are as designated in MIL-STD-1835 and as follows:

<u>Outline letter</u>	<u>Descriptive designator</u>	<u>Terminals</u>	<u>Package style</u>
A	GDFP5-F14 or CDFP6-F14	14	Flat pack
C	GDIP1-T14 or CDIP2-T14	14	Dual-in-line
D	GDFP1-F14 or CDFP2-F14	14	Flat pack
2	CQCC1-N20	20	Square leadless chip carrier

1.2.5 Lead finish. The lead finish is as specified in MIL-PRF-38535 for device classes Q and V or MIL-PRF-38535, appendix A for device class M.

1.3 Absolute maximum ratings. 1/

Supply voltage ( $V_{CC}$ ) 2/ .....	7.0 V dc
Input voltage .....	5.5 V dc
Output short circuit duration 3/ .....	1 second
Lead temperature (soldering 10 seconds).....	300°C
Storage temperature range .....	-65°C to +150°C
Power dissipation ( $P_D$ ) .....	600 mW 4/ 5/
Thermal resistance, junction to case ( $\theta_{JC}$ ):.....	See MIL-STD-1835
Junction temperature ( $T_J$ ).....	150°C

1.4 Recommended operating conditions.

Supply voltage ( $V_{CC}$ ) .....	4.5 V dc to 5.5 V dc
High level output current ( $I_{OH}$ ) .....	-40 mA maximum
Low level output current ( $I_{OL}$ ) .....	40 mA maximum
Ambient operating temperature range ( $T_A$ ) .....	-55°C to +125°C

1/ Stresses above the absolute maximum rating may cause permanent damage to the device. Extended operation at the maximum levels may degrade performance and affect reliability.

2/ All voltage values, except differential voltages, are with respect to network ground terminal.

3/ At +125°C not more than one output should be shorted to ground at a time.

4/ Derate 10.4 mW/°C above  $T_A = 90^\circ\text{C}$ .

5/ Must withstand the added  $P_D$  due to short circuit test, e.g.,  $I_{OS}$ .

<b>STANDARD MICROCIRCUIT DRAWING</b> DLA LAND AND MARITIME COLUMBUS, OHIO 43218-3990	SIZE <b>A</b>		<b>79009</b>
		REVISION LEVEL <b>K</b>	SHEET <b>3</b>

## 2. APPLICABLE DOCUMENTS

2.1 Government specification, standards, and handbooks. The following specification, standards, and handbooks form a part of this drawing to the extent specified herein. Unless otherwise specified, the issues of these documents are those cited in the solicitation or contract.

### DEPARTMENT OF DEFENSE SPECIFICATION

MIL-PRF-38535 - Integrated Circuits, Manufacturing, General Specification for.

### DEPARTMENT OF DEFENSE STANDARDS

MIL-STD-883 - Test Method Standard Microcircuits.

MIL-STD-1835 - Interface Standard Electronic Component Case Outlines.

### DEPARTMENT OF DEFENSE HANDBOOKS

MIL-HDBK-103 - List of Standard Microcircuit Drawings.

MIL-HDBK-780 - Standard Microcircuit Drawings.

(Copies of these documents are available online at <https://quicksearch.dla.mil/>.)

2.2 Order of precedence. In the event of a conflict between the text of this drawing and the references cited herein, the text of this drawing takes precedence. Nothing in this document, however, supersedes applicable laws and regulations unless a specific exemption has been obtained.

## 3. REQUIREMENTS

3.1 Item requirements. The individual item requirements for device classes Q and V shall be in accordance with MIL-PRF-38535 and as specified herein or as modified in the device manufacturer's Quality Management (QM) plan. The modification in the QM plan shall not affect the form, fit, or function as described herein. The individual item requirements for device class M shall be in accordance with MIL-PRF-38535, appendix A for non-JAN class level B devices and as specified herein.

3.2 Design, construction, and physical dimensions. The design, construction, and physical dimensions shall be as specified in MIL-PRF-38535 and herein for device classes Q and V or MIL-PRF-38535, appendix A and herein for device class M.

3.2.1 Case outlines. The case outlines shall be in accordance with 1.2.4 herein.

3.2.2 Terminal connections. The terminal connections shall be as specified on figure 1.

3.3 Electrical performance characteristics and postirradiation parameter limits. Unless otherwise specified herein, the electrical performance characteristics and postirradiation parameter limits are as specified in table I and shall apply over the full ambient operating temperature range.

3.4 Electrical test requirements. The electrical test requirements shall be the subgroups specified in table IIA. The electrical tests for each subgroup are defined in table I.

3.5 Marking. The part shall be marked with the PIN listed in 1.2 herein. In addition, the manufacturer's PIN may also be marked. For packages where marking of the entire SMD PIN number is not feasible due to space limitations, the manufacturer has the option of not marking the "5962-" on the device. For RHA product using this option, the RHA designator shall still be marked. Marking for device classes Q and V shall be in accordance with MIL-PRF-38535. Marking for device class M shall be in accordance with MIL-PRF-38535, appendix A.

<b>STANDARD MICROCIRCUIT DRAWING</b> DLA LAND AND MARITIME COLUMBUS, OHIO 43218-3990	<b>SIZE A</b>		<b>79009</b>
		<b>REVISION LEVEL K</b>	<b>SHEET 4</b>

TABLE I. Electrical performance characteristics.

Test	Symbol	Conditions -55°C ≤ T <sub>A</sub> ≤ +125°C 4.5 V ≤ V <sub>CC</sub> ≤ 5.5 V unless otherwise specified	Group A subgroups	Device type	Limits		Unit
					Min	Max	
High level input voltage	V <sub>IH</sub>		1, 2, 3	All	2.0		V
Low level input voltage	V <sub>IL</sub>		1, 2, 3	All		0.8	V
High level output voltage (Y output)	V <sub>OH</sub>	V <sub>IH</sub> = 2.0 V, I <sub>OH</sub> = -0.8 mA	1, 2, 3	All	2.4		V
		V <sub>IH</sub> = 2.0 V, I <sub>OH</sub> = -40 mA			1.8		
Low level output voltage (Y output)	V <sub>OL</sub>	V <sub>IL</sub> = 0.8 V, I <sub>OL</sub> = 40 mA	1, 2, 3	All		0.4	V
High level output voltage (Z output)	V <sub>OH</sub>	V <sub>IL</sub> = 0.8 V, I <sub>OH</sub> = -0.8 mA	1, 2, 3	All	2.4		V
		V <sub>IL</sub> = 0.8 V, I <sub>OH</sub> = -40 mA			1.8		
Low level output voltage (Z output)	V <sub>OL</sub>	V <sub>IH</sub> = 2.0 V, I <sub>OL</sub> = 40 mA	1, 2, 3	All		0.5	V
High level input current	I <sub>IH</sub>	V <sub>IH</sub> = 2.4 V	1, 2, 3	All		120	μA
		V <sub>IH</sub> = 5.5 V				2	
Low level input current	I <sub>IL</sub>	V <sub>IL</sub> = 0.4 V	1, 2, 3	All		-4.8	mA
Short circuit output current	I <sub>OS</sub>	V <sub>CC</sub> = 5 V, T <sub>A</sub> = +125°C	2	All	-40	-120	mA
Supply current (average per driver)	I <sub>CC</sub>	V <sub>CC</sub> = 5 V	1, 2, 3	All		18	mA
Propagation delay time low to high (Y output) <u>1/</u>	t <sub>PLH1</sub>	C <sub>L</sub> = 15 pF, V <sub>CC</sub> = 5.0 V	9	All		12	ns
			10, 11 <u>2/</u>			17	
Propagation delay time high to low (Y output) <u>1/</u>	t <sub>PHL1</sub>	C <sub>L</sub> = 15 pF, V <sub>CC</sub> = 5.0 V	9	All		18	ns
			10, 11 <u>2/</u>			25	
Propagation delay time low to high (Z output) <u>1/</u>	t <sub>PLH2</sub>	C <sub>L</sub> = 15 pF, V <sub>CC</sub> = 5.0 V	9	All		12	ns
			10, 11 <u>2/</u>			17	
Propagation delay time high to low (Z output) <u>1/</u>	t <sub>PHL2</sub>	C <sub>L</sub> = 15 pF, V <sub>CC</sub> = 5.0 V	9	All		8	ns
			10, 11 <u>2/</u>			11	
Propagation delay time low to high (differential output) <u>1/</u>	t <sub>PLH3</sub>	R <sub>L</sub> = 100 Ω, C <sub>L</sub> = 5000 pF, (Y output with respect to Z output), T <sub>A</sub> = +25°C	9	All		16	ns
Propagation delay time high to low (differential output) <u>1/</u>	t <sub>PHL3</sub>	R <sub>L</sub> = 100 Ω, C <sub>L</sub> = 5000 pF, (Y output with respect to Z output), T <sub>A</sub> = +25°C	9	All		16	ns

1/ See figure 2.

2/ Guaranteed, if not tested, to the limits specified.

<b>STANDARD MICROCIRCUIT DRAWING</b> DLA LAND AND MARITIME COLUMBUS, OHIO 43218-3990	SIZE <b>A</b>		<b>79009</b>
		REVISION LEVEL <b>K</b>	SHEET <b>5</b>

Device type	All	
Case outline	A, C, and D	2
Terminal number	Terminal symbol	
1	1A	NC
2	1B	1A
3	1C	1B
4	1D	1C
5	1Y	NC
6	1Z	1D
7	GND	NC
8	2Z	1Y
9	2Y	1Z
10	2A	GND
11	2B	NC
12	2C	2Z
13	2D	2Y
14	V <sub>CC</sub>	2A
15	----	NC
16	----	2B
17	----	NC
18	----	2C
19	----	2D
20	----	V <sub>CC</sub>

FIGURE 1. Terminal connections.

**STANDARD  
MICROCIRCUIT DRAWING**  
DLA LAND AND MARITIME  
COLUMBUS, OHIO 43218-3990

SIZE  
**A**

REVISION LEVEL  
**K**

**79009**

SHEET **6**

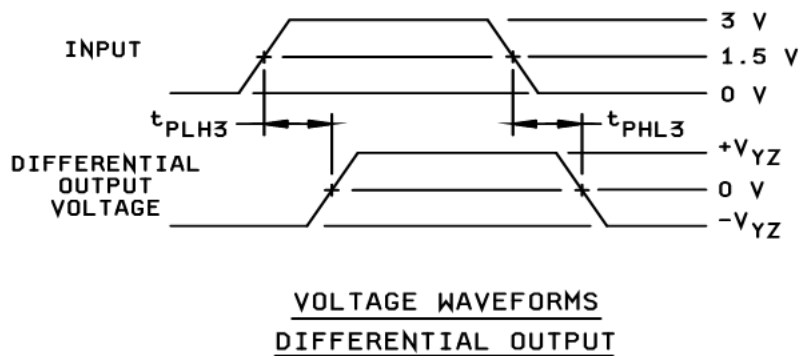
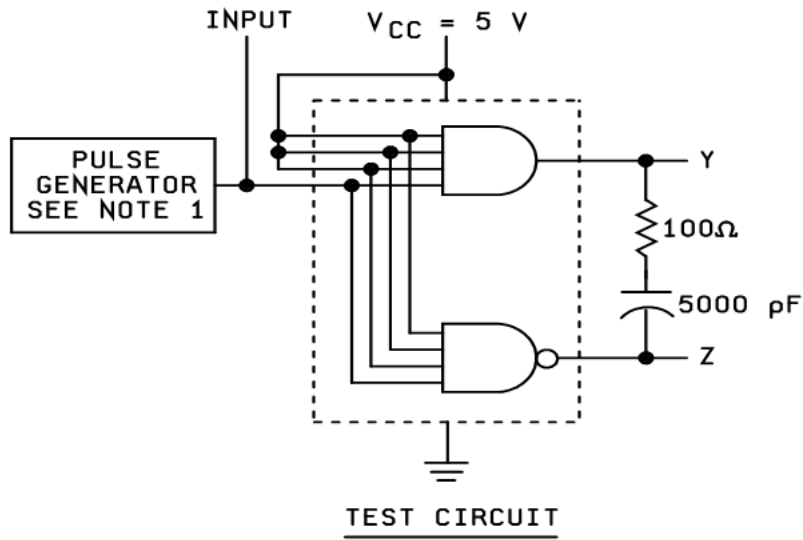

NOTES:

1. The pulse generator has the following characteristics:  
 $Z_o = 50 \Omega$ ,  $t_f = 10 \text{ ns}$ ,  $\text{PRR} = 1 \text{ MHz}$ ,  $t_r = 10 \text{ ns}$ ,  $t_w = 0.5 \mu\text{s}$ .
2.  $C_L$  includes probe and jig capacitance.

FIGURE 2. Voltage waveforms and test circuit.

**STANDARD  
MICROCIRCUIT DRAWING**  
DLA LAND AND MARITIME  
COLUMBUS, OHIO 43218-3990

SIZE  
**A**

**79009**

REVISION LEVEL  
**K**

SHEET **7**

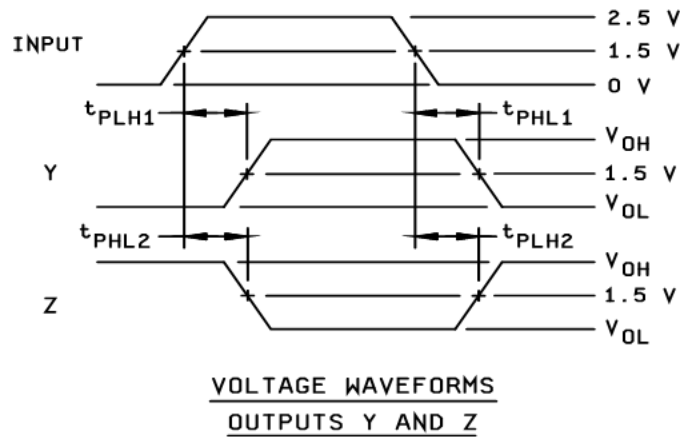
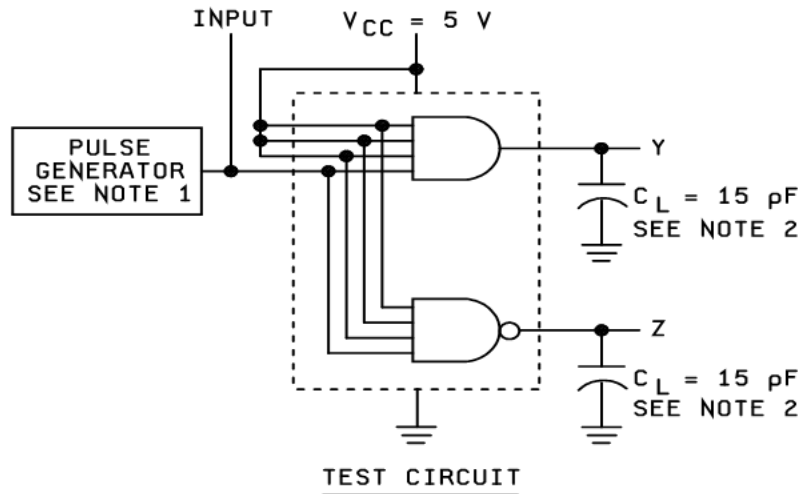

**NOTES:**

1. The pulse generator has the following characteristics:  
 $Z_o = 50 \Omega$ ,  $t_f = 10 \text{ ns}$ ,  $\text{PRR} = 1 \text{ MHz}$ ,  $t_r = 10 \text{ ns}$ ,  $t_w = 0.5 \mu\text{s}$ .
2.  $C_L$  includes probe and jig capacitance.

FIGURE 2. Voltage waveforms and test circuit – Continued.

<b>STANDARD MICROCIRCUIT DRAWING</b> DLA LAND AND MARITIME COLUMBUS, OHIO 43218-3990	SIZE <b>A</b>		<b>79009</b>
		REVISION LEVEL <b>K</b>	SHEET <b>8</b>



3.5.1 Certification/compliance mark. The certification mark for device classes Q and V shall be a "QML" or "Q" as required in MIL-PRF-38535. The compliance mark for device class M shall be a "C" as required in MIL-PRF-38535, appendix A.

3.6 Certificate of compliance. For device classes Q and V, a certificate of compliance shall be required from a QML-38535 listed manufacturer in order to supply to the requirements of this drawing (see 6.6.1 herein). For device class M, a certificate of compliance shall be required from a manufacturer in order to be listed as an approved source of supply in MIL-HDBK-103 (see 6.6.2 herein). The certificate of compliance submitted to DLA Land and Maritime-VA prior to listing as an approved source of supply for this drawing shall affirm that the manufacturer's product meets, for device classes Q and V, the requirements of MIL-PRF-38535 and herein or for device class M, the requirements of MIL-PRF-38535, appendix A and herein.

3.7 Certificate of conformance. A certificate of conformance as required for device classes Q and V in MIL-PRF-38535 or for device class M in MIL-PRF-38535, appendix A shall be provided with each lot of microcircuits delivered to this drawing.

3.8 Notification of change for device class M. For device class M, notification to DLA Land and Maritime-VA of change of product (see 6.2 herein) involving devices acquired to this drawing is required for any change that affects this drawing.

3.9 Verification and review for device class M. For device class M, DLA Land and Maritime, DLA Land and Maritime 's agent, and the acquiring activity retain the option to review the manufacturer's facility and applicable required documentation. Offshore documentation shall be made available onshore at the option of the reviewer.

3.10 Microcircuit group assignment for device class M. Device class M devices covered by this drawing shall be in microcircuit group number 53 (see MIL-PRF-38535, appendix A).

#### 4. VERIFICATION

4.1 Sampling and inspection. For device classes Q and V, sampling and inspection procedures shall be in accordance with MIL-PRF-38535 or as modified in the device manufacturer's Quality Management (QM) plan. The modification in the QM plan shall not affect the form, fit, or function as described herein. For device class M, sampling and inspection procedures shall be in accordance with MIL-PRF-38535, appendix A.

4.2 Screening. For device classes Q and V, screening shall be in accordance with MIL-PRF-38535, and shall be conducted on all devices prior to qualification and technology conformance inspection. For device class M, screening shall be in accordance with method 5004 of MIL-STD-883, and shall be conducted on all devices prior to quality conformance inspection.

##### 4.2.1 Additional criteria for device class M.

a. Burn-in test, method 1015 of MIL-STD-883.

(1) Test condition A, B, C, or D. The test circuit shall be maintained by the manufacturer under document revision level control and shall be made available to the preparing or acquiring activity upon request. The test circuit shall specify the inputs, outputs, biases, and power dissipation, as applicable, in accordance with the intent specified in method 1015 of MIL-STD-883.

(2)  $T_A = +125^{\circ}\text{C}$ , minimum.

b. Interim and final electrical test parameters shall be as specified in table IIA herein, except interim electrical parameter tests prior to burn-in are optional at the discretion of the manufacturer.

<b>STANDARD MICROCIRCUIT DRAWING</b> DLA LAND AND MARITIME COLUMBUS, OHIO 43218-3990	<b>SIZE A</b>		<b>79009</b>
		<b>REVISION LEVEL K</b>	<b>SHEET 9</b>

4.2.2 Additional criteria for device classes Q and V.

- a. The burn-in test duration, test condition and test temperature, or approved alternatives shall be as specified in the device manufacturer's QM plan in accordance with MIL-PRF-38535. The burn-in test circuit shall be maintained under document revision level control of the device manufacturer's Technology Review Board (TRB) in accordance with MIL-PRF-38535 and shall be made available to the acquiring or preparing activity upon request. The test circuit shall specify the inputs, outputs, biases, and power dissipation, as applicable, in accordance with the intent specified in method 1015 of MIL-STD-883.
- b. Interim and final electrical test parameters shall be as specified in table IIA herein.
- c. Additional screening for device class V beyond the requirements of device class Q shall be as specified in MIL-PRF-38535, Appendix B.

4.3 Qualification inspection for device classes Q and V. Qualification inspection for device classes Q and V shall be in accordance with MIL-PRF-38535. Inspections to be performed shall be those specified in MIL-PRF-38535 and herein for groups A, B, C, D, and E inspections (see 4.4.1 through 4.4.4).

4.4 Conformance inspection. Technology conformance inspection for classes Q and V shall be in accordance with MIL-PRF-38535 including groups A, B, C, D, and E inspections and as specified. Quality conformance inspection for device class M shall be in accordance with MIL-PRF-38535, appendix A and as specified herein. Inspections to be performed for device class M shall be those specified in method 5005 of MIL-STD-883 and herein for groups A, B, C, D, and E inspections (see 4.4.1 through 4.4.4).

4.4.1 Group A inspection.

- a. Tests shall be as specified in table IIA herein.
- b. Subgroups 4, 5, 6, 7, and 8 in table I, method 5005 of MIL-STD-883 shall be omitted.

4.4.2 Group C inspection. The group C inspection end-point electrical parameters shall be as specified in table IIA herein.

4.4.2.1 Additional criteria for device class M. Steady-state life test conditions, method 1005 of MIL-STD-883:

- a. Test condition A, B, C, or D. The test circuit shall be maintained by the manufacturer under document revision level control and shall be made available to the preparing or acquiring activity upon request. The test circuit shall specify the inputs, outputs, biases, and power dissipation, as applicable, in accordance with the intent specified in method 1005 of MIL-STD-883.
- b.  $T_A = +125^{\circ}\text{C}$ , minimum.
- c. Test duration: 1,000 hours, except as permitted by method 1005 of MIL-STD-883.

4.4.2.2 Additional criteria for device classes Q and V. The steady-state life test duration, test condition and test temperature, or approved alternatives shall be as specified in the device manufacturer's QM plan in accordance with MIL-PRF-38535. The test circuit shall be maintained under document revision level control by the device manufacturer's TRB in accordance with MIL-PRF-38535 and shall be made available to the acquiring or preparing activity upon request. The test circuit shall specify the inputs, outputs, biases, and power dissipation, as applicable, in accordance with the intent specified in method 1005 of MIL-STD-883.

<b>STANDARD MICROCIRCUIT DRAWING</b> DLA LAND AND MARITIME COLUMBUS, OHIO 43218-3990	SIZE <b>A</b>		<b>79009</b>
		REVISION LEVEL <b>K</b>	SHEET <b>10</b>

TABLE IIA. Electrical test requirements.

Test requirements	Subgroups (in accordance with MIL-STD-883, method 5005, table I)	Subgroups (in accordance with MIL-PRF-38535, table III)	
	Device class M	Device class Q	Device class V
Interim electrical parameters (see 4.2)	1	1	1
Final electrical parameters (see 4.2)	1, 2, 3, 9 <u>1/</u>	1, 2, 3, 9 <u>1/</u>	1, 2, 3, 9 <u>1/</u> <u>3/</u>
Group A test requirements (see 4.4)	1, 2, 3, <u>2/</u> 9, 10, 11	1, 2, 3, <u>2/</u> 9, 10, 11	1, 2, 3, <u>2/</u> 9, 10, 11
Group C end-point electrical parameters (see 4.4)	1, 2, 3	1, 2, 3	1, 2, 3 <u>3/</u>
Group D end-point electrical parameters (see 4.4)	1, 2, 3	1, 2, 3	1, 2, 3
Group E end-point electrical parameters (see 4.4)	----	----	----

1/ PDA applies to subgroup 1.

2/ Subgroups 10 and 11, if not tested, shall be guaranteed to the specified limits in table I.

3/ Delta limits as specified in table IIB shall be required where specified, and the delta limits shall be computed with reference to the zero hour electrical parameters.

TABLE IIB. Burn-in and operating life test. Delta parameters (+25°C).

Parameters <u>1/</u>	Symbol	Delta limits
Quiescent current	I <sub>CC</sub>	±1.8 mA
Output voltage low level (I <sub>OL</sub> = 40 mA, V <sub>CC</sub> 4.5 V)	V <sub>OL</sub>	±0.04 V
Output voltage high level (I <sub>OH</sub> = -40 mA, V <sub>CC</sub> = 4.5 V)	V <sub>OH</sub>	±0.18 V

1/ These parameters shall be recorded before and after the required burn-in and life test to determine delta limits

<b>STANDARD MICROCIRCUIT DRAWING</b> DLA LAND AND MARITIME COLUMBUS, OHIO 43218-3990	SIZE <b>A</b>		<b>79009</b>
		REVISION LEVEL <b>K</b>	SHEET <b>11</b>

4.4.3 Group D inspection. The group D inspection end-point electrical parameters shall be as specified in table IIA herein.

4.4.4 Group E inspection. Group E inspection is required only for parts intended to be marked as radiation hardness assured (see 3.5 herein).

- a. End-point electrical parameters shall be as specified in table IIA herein.
- b. For device classes Q and V, the devices or test vehicle shall be subjected to radiation hardness assured tests as specified in MIL-PRF-38535 for the RHA level being tested. For device class M, the devices shall be subjected to radiation hardness assured tests as specified in MIL-PRF-38535, appendix A for the RHA level being tested. All device classes must meet the postirradiation end-point electrical parameter limits as defined in table I at  $T_A = +25^{\circ}\text{C} \pm 5^{\circ}\text{C}$ , after exposure, to the subgroups specified in table IIA herein.

## 5. PACKAGING

5.1 Packaging requirements. The requirements for packaging shall be in accordance with MIL-PRF-38535 for device classes Q and V or MIL-PRF-38535, appendix A for device class M.

## 6. NOTES

6.1 Intended use. Microcircuits conforming to this drawing are intended for use for Government microcircuit applications (original equipment), design applications, and logistics purposes.

6.1.1 Replaceability. Microcircuits covered by this drawing will replace the same generic device covered by a contractor-prepared specification or drawing.

6.2 Configuration control of SMD's. All proposed changes to existing SMD's will be coordinated with the users of record for the individual documents. This coordination will be accomplished using DD Form 1692, Engineering Change Proposal, or email communication.

6.3 Record of users. Military and industrial users should inform DLA Land and Maritime when a system application requires configuration control and which SMD's are applicable to that system. DLA Land and Maritime will maintain a record of users and this list will be used for coordination and distribution of changes to the drawings. Users of drawings covering microelectronic devices (FSC 5962) should contact DLA Land and Maritime-VA, telephone (614) 692-8108.

6.4 Comments. Comments on this drawing should be directed to DLA Land and Maritime-VA, Columbus, Ohio 43218-3990, or telephone (614) 692-0591.

6.5 Abbreviations, symbols, and definitions. The abbreviations, symbols, and definitions used herein are defined in MIL-PRF-38535 and MIL-HDBK-1331.

6.6 Sources of supply.

6.6.1 Sources of supply for device classes Q and V. Sources of supply for device classes Q and V are listed in MIL-HDBK-103 and QML-38535. The vendors listed in MIL-HDBK-103 and QML-38535 have submitted a certificate of compliance (see 3.6 herein) to DLA Land and Maritime-VA and have agreed to this drawing.

6.6.2 Approved sources of supply for device class M. Approved sources of supply for class M are listed in MIL-HDBK-103. The vendors listed in MIL-HDBK-103 have agreed to this drawing and a certificate of compliance (see 3.6 herein) has been submitted to and accepted by DLA Land and Maritime-VA.

<b>STANDARD MICROCIRCUIT DRAWING</b> DLA LAND AND MARITIME COLUMBUS, OHIO 43218-3990	SIZE <b>A</b>		<b>79009</b>
		REVISION LEVEL <b>K</b>	SHEET <b>12</b>

STANDARD MICROCIRCUIT DRAWING BULLETIN

DATE: 23-03-24

Approved sources of supply for SMD 79009 are listed below for immediate acquisition information only and shall be added to MIL-HDBK-103 and QML-38535 during the next revision. MIL-HDBK-103 and QML-38535 will be revised to include the addition or deletion of sources. The vendors listed below have agreed to this drawing and a certificate of compliance has been submitted to and accepted by DLA Land and Maritime-VA. This information bulletin is superseded by the next dated revision of MIL-HDBK-103 and QML-38535. DLA Land and Maritime maintains an online database of all current sources of supply at <https://landandmaritimeapps.dla.mil/programs/smcr/>.

Standard microcircuit drawing PIN <u>1/</u>	Vendor CAGE number	Vendor similar PIN <u>2/</u>
7900901AA	<u>3/</u>	DS7830W
79009012A	01295	SNJ55183FK
7900901CA	01295	SNJ55183J
7900901DA	<u>3/</u>	SNJ55183W
5962-7900901VCA	01295	SNV55183J

1/ The lead finish shown for each PIN representing a hermetic package is the most readily available from the manufacturer listed for that part. If the desired lead finish is not listed contact the vendor to determine its availability.

2/ Caution. Do not use this number for item acquisition. Items acquired to this number may not satisfy the performance requirements of this drawing.

3/ Not available from an approved source of supply.

Vendor CAGE  
number

01295

Vendor name  
and address

Texas Instruments, Incorporated  
Semiconductor Group  
8505 Forest Lane  
P.O. Box 660199  
Dallas, TX 75243

The information contained herein is disseminated for convenience only and the Government assumes no liability whatsoever for any inaccuracies in the information bulletin.