

REVISIONS			
LTR	DESCRIPTION	DATE (YR-MO-DA)	APPROVED
K	Add device type 02 and add vendor CAGE 27014. Change to one part-one part number format. Technical changes to 1.3, 1.4, table I, and table II. Change figure 2 to figure 3. Add figure 2. - mlp	91-04-19	M. A. Frye
L	Changes in accordance with N.O.R. 5962-R062-92. - jt	91-11-22	M. Poelking
M	Changes in accordance with N.O.R. 5962-R168-98. - drw	98-09-01	R. Monnin
N	Add radiation hardened information. Editorial changes throughout. - drw	99-05-12	R. Monnin
P	Make change to 3.2.5. Delete the radiation hardened circuit as specified in figure 4. - ro	00-10-26	R. Monnin
R	Add case outline Z. - ro	01-05-02	R. Monnin
T	Redraw. Update drawing to current requirements. - drw	12-01-26	Charles F. Saffle
U	Update paragraphs to MIL-PRF-38535 requirements. - drw	18-06-22	Charles F. Saffle

THE ORIGINAL FIRST SHEET OF THIS DRAWING HAS BEEN REPLACED.



REV																				
SHEET																				
REV	U	U																		
SHEET	15	16																		
REV STATUS	REV		U	U	U	U	U	U	U	U	U	U	U	U	U	U	U	U	U	
OF SHEETS	SHEET		1	2	3	4	5	6	7	8	9	10	11	12	13	14				
PMIC N/A	PREPARED BY Joan M. Fisher				DLA LAND AND MARITIME COLUMBUS, OHIO 43218-3990 http://www.dla.mil/landandmaritime MICROCIRCUIT, LINEAR, QUAD HIGH SPEED DIFFERENTIAL LINE DRIVER, MONOLITHIC SILICON															
STANDARD MICROCIRCUIT DRAWING THIS DRAWING IS AVAILABLE FOR USE BY ALL DEPARTMENTS AND AGENCIES OF THE DEPARTMENT OF DEFENSE	CHECKED BY C. R. Jackson																			
	APPROVED BY N. A. Hauck																			
	DRAWING APPROVAL DATE 79-02-02																			
AMSC N/A	REVISION LEVEL U				SIZE A	CAGE CODE 67268		78023												
										SHEET		1 OF 16								

1. SCOPE

1.1 Scope. This drawing documents two product assurance class levels consisting of high reliability (device class Q and M) and space application (device class V). A choice of case outlines and lead finishes are available and are reflected in the Part or Identifying Number (PIN). When available, a choice of Radiation Hardness Assurance (RHA) levels is reflected in the PIN.

1.2 PIN. The PIN is as shown in the following example:

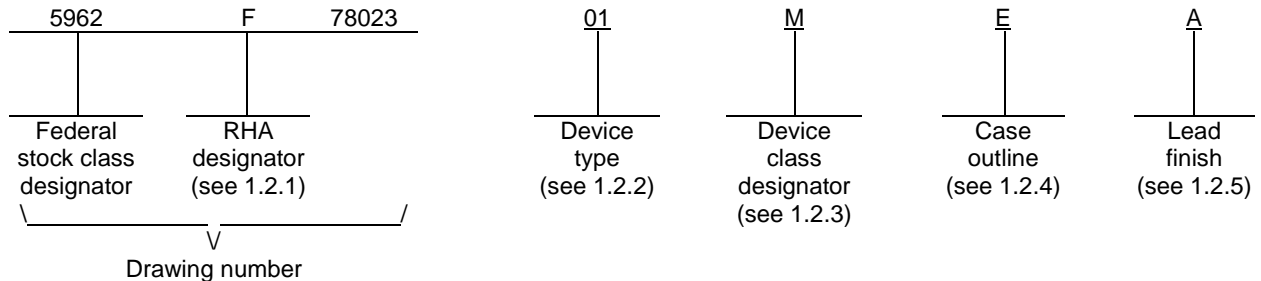

1.2.1 RHA designator. Device classes Q and V RHA marked devices meet the MIL-PRF-38535 specified RHA levels and are marked with the appropriate RHA designator. Device class M RHA marked devices meet the MIL-PRF-38535, appendix A specified RHA levels and are marked with the appropriate RHA designator. A dash (-) indicates a non-RHA device.

1.2.2 Device types. The device types identify the circuit function as follows:

<u>Device type</u>	<u>Generic number</u>	<u>Circuit function</u>
01	26LS31	Quad, high speed, differential line driver
02	26F31	Quad, high speed, differential line driver

1.2.3 Device class designator. The device class designator is a single letter identifying the product assurance level as follows:

<u>Device class</u>	<u>Device requirements documentation</u>
M	Vendor self-certification to the requirements for MIL-STD-883 compliant, non-JAN class level B microcircuits in accordance with MIL-PRF-38535, appendix A
Q or V	Certification and qualification to MIL-PRF-38535

1.2.4 Case outlines. The case outlines are as designated in MIL-STD-1835 as follows:

<u>Outline letter</u>	<u>Descriptive designator</u>	<u>Terminals</u>	<u>Package style</u>
E	GDIP1-T16 or CDIP2-T16	16	Dual-in-line
F	GDFP2-F16 or CDFP3-F16	16	Flat pack
Z	GDFP1-G16	16	Flat pack with gullwing leads
2	CQCC1-N20	20	Square leadless chip carrier

1.2.5 Lead finish. The lead finish is as specified in MIL-PRF-38535 for device classes Q and V or MIL-PRF-38535, appendix A for device class M.

STANDARD MICROCIRCUIT DRAWING DLA LAND AND MARITIME COLUMBUS, OHIO 43218-3990	SIZE A		78023
		REVISION LEVEL U	SHEET 2

1.3 Absolute maximum ratings. 1/

Power supply and input voltage	7.0 V dc
Output voltage.....	5.5 V dc
Storage temperature range	-65°C to +150°C
Lead temperature (soldering, 10 seconds)	+300°C
Maximum power dissipation (PD).....	450 mW 2/
Junction temperature (TJ)	+150°C
Thermal resistance, junction-to-case (θ_{JC}):	
Device 01:	
Case E	16°C/W
Case F	14°C/W
Case 2	19°C/W
Device 02:	
Case E	14°C/W
Cases F and Z	13°C/W
Case 2	15°C/W
Thermal resistance, junction-to-ambient (θ_{JA}):	
Device 01:	
Case E	94°C/W derate above +25°C at 10.6 mW/°C
Case F	163°C/W derate above +25°C at 6.1 mW/°C
Case 2	83°C/W derate above +25°C at 12 mW/°C
Device 02:	
Case E	88°C/W derate above +25°C at 11.4 mW/°C
Cases F and Z	151°C/W derate above +25°C at 6.6 mW/°C
Case 2	81°C/W derate above +25°C at 12.3 mW/°C

1.4 Recommended operating conditions.

Supply voltage range (VCC).....	4.5 V dc to 5.5 V dc
Minimum high-level input voltage (V _{IH}).....	2.0 V dc
Maximum low-level input voltage (V _{IL}).....	0.8 V dc
Ambient operating temperature range (T _A).....	-55°C to +125°C

1.5 Radiation features.

Maximum total dose available (dose rate = 50 to 300 rads (Si)/s)..... 300 Krads(Si) 3/

- 1/ Stresses above the absolute maximum rating may cause permanent damage to the device. Extended operation at the maximum levels may degrade performance and affect reliability.
- 2/ Must withstand the added PD due to short circuit test: e.g., IOS.
- 3/ These parts may be dose rate sensitive in a space environment and may demonstrate enhanced low dose rate effects. Radiation end point limits for the noted parameters are guaranteed only for the conditions specified in MIL-STD-883, method 1019, condition A.

STANDARD MICROCIRCUIT DRAWING DLA LAND AND MARITIME COLUMBUS, OHIO 43218-3990	SIZE A		78023
		REVISION LEVEL U	SHEET 3

2. APPLICABLE DOCUMENTS

2.1 Government specification, standards, and handbooks. The following specification, standards, and handbooks form a part of this drawing to the extent specified herein. Unless otherwise specified, the issues of these documents are those cited in the solicitation or contract.

DEPARTMENT OF DEFENSE SPECIFICATION

MIL-PRF-38535 - Integrated Circuits, Manufacturing, General Specification for.

DEPARTMENT OF DEFENSE STANDARDS

MIL-STD-883 - Test Method Standard Microcircuits.
MIL-STD-1835 - Interface Standard Electronic Component Case Outlines.

DEPARTMENT OF DEFENSE HANDBOOKS

MIL-HDBK-103 - List of Standard Microcircuit Drawings.
MIL-HDBK-780 - Standard Microcircuit Drawings.

(Copies of these documents are available online at <http://quicksearch.dla.mil>).

2.2 Order of precedence. In the event of a conflict between the text of this drawing and the references cited herein, the text of this drawing takes precedence. Nothing in this document, however, supersedes applicable laws and regulations unless a specific exemption has been obtained.

3. REQUIREMENTS

3.1 Item requirements. The individual item requirements for device classes Q and V shall be in accordance with MIL-PRF-38535 as specified herein, or as modified in the device manufacturer's Quality Management (QM) plan. The modification in the QM plan shall not affect the form, fit, or function as described herein. The individual item requirements for device class M shall be in accordance with MIL-PRF-38535, appendix A for non-JAN class level B devices and as specified herein.

3.2 Design, construction, and physical dimensions. The design, construction, and physical dimensions shall be as specified in MIL-PRF-38535 and herein for device classes Q and V or MIL-PRF-38535, appendix A and herein for device class M.

3.2.1 Case outlines. The case outlines shall be in accordance with 1.2.4 herein.

3.2.2 Terminal connections. The terminal connections shall be as specified on figure 1.

3.2.3 Block diagram. The block diagram shall be as specified on figure 2.

3.2.4 Test circuit and switching waveforms. The test circuit and switching waveforms shall be as specified on figure 3.

3.2.5 Radiation exposure circuit. The radiation exposure circuit shall be maintained by the manufacturer under document revision level control and shall be made available to the preparing and acquiring activity upon request.

3.3 Electrical performance characteristics and postirradiation parameter limits. Unless otherwise specified herein, the electrical performance characteristics and postirradiation parameter limits are as specified in table I and shall apply over the full ambient operating temperature range.

3.4 Electrical test requirements. The electrical test requirements shall be the subgroups specified in table IIA. The electrical tests for each subgroup are defined in table I.

STANDARD MICROCIRCUIT DRAWING DLA LAND AND MARITIME COLUMBUS, OHIO 43218-3990	SIZE A		78023
		REVISION LEVEL U	SHEET 4

3.5 Marking. The part shall be marked with the PIN listed in 1.2 herein. In addition, the manufacturer's PIN may also be marked. For packages where marking of the entire SMD PIN number is not feasible due to space limitations, the manufacturer has the option of not marking the "5962-" on the device. For RHA product using this option, the RHA designator shall still be marked. Marking for device classes Q and V shall be in accordance with MIL-PRF-38535. Marking for device class M shall be in accordance with MIL-PRF-38535, appendix A.

3.5.1 Certification/compliance mark. The certification mark for device classes Q and V shall be a "QML" or "Q" as required in MIL-PRF-38535. The compliance mark for device class M shall be a "C" as required in MIL-PRF-38535, appendix A.

3.6 Certificate of compliance. For device classes Q and V, a certificate of compliance shall be required from a QML-38535 listed manufacturer in order to supply to the requirements of this drawing (see 6.6.1 herein). For device class M, a certificate of compliance shall be required from a manufacturer in order to be listed as an approved source of supply in MIL-HDBK-103 (see 6.6.2 herein). The certificate of compliance submitted to DLA Land and Maritime-VA prior to listing as an approved source of supply for this drawing shall affirm that the manufacturer's product meets, for device classes Q and V, the requirements of MIL-PRF-38535 and herein or for device class M, the requirements of MIL-PRF-38535, appendix A and herein.

3.7 Certificate of conformance. A certificate of conformance as required for device classes Q and V in MIL-PRF-38535 or for device class M in MIL-PRF-38535, appendix A shall be provided with each lot of microcircuits delivered to this drawing.

3.8 Notification of change for device class M. For device class M, notification to DLA Land and Maritime-VA of change of product (see 6.2 herein) involving devices acquired to this drawing is required for any change that affects this drawing.

3.9 Verification and review for device class M. For device class M, DLA Land and Maritime, DLA Land and Maritime's agent, and the acquiring activity retain the option to review the manufacturer's facility and applicable required documentation. Offshore documentation shall be made available onshore at the option of the reviewer.

3.10 Microcircuit group assignment for device class M. Device class M devices covered by this drawing shall be in microcircuit group number 53 (see MIL-PRF-38535, appendix A).

STANDARD MICROCIRCUIT DRAWING DLA LAND AND MARITIME COLUMBUS, OHIO 43218-3990	SIZE A		78023
		REVISION LEVEL U	SHEET 5

TABLE I. Electrical performance characteristics.

Test (MIL-STD-883 test method)	Symbol	Condition <u>1/</u> , <u>2/</u> -55°C ≤ TA ≤ +125°C unless otherwise specified	Group A subgroups	Device type	Limits		Unit
					Min	Max	
Output high voltage (3006)	VOH	VCC = 4.5 V, IOH = -20 mA	1, 2, 3	All	2.5		V
		M, D, P, L, R, F	1		2.5		
Output low voltage (3007)	VOL	VCC = 4.5 V, IOH = 20 mA	1, 2, 3	All		0.5	V
		M, D, P, L, R, F	1			0.5	
Input high voltage	VIH	VCC = 4.5 V <u>3/</u>	1, 2, 3	All	2.0		V
Input low voltage	VIL	VCC = 5.5 V <u>3/</u>	1, 2, 3	All		0.8	V
Input low current (3009)	IIL	VCC = 5.5 V, <u>4/</u> VIN = 0.4 V	1, 2, 3	01	0.10	-0.36	mA
				02	0.10	-0.20	
		M, D, P, L, R, F	1	01	0.10	-0.36	
				02	0.10	-0.20	
Input high current (3010)	IIH	VCC = 5.5 V, <u>4/</u> VIN = 2.7 V	1, 2, 3	All	-2.0	20	μA
		M, D, P, L, R, F	1		-2.0	20	
Input reverse current	II	VCC = 5.5 V, <u>4/</u> VIN = 7.0 V	1, 2, 3	All	-0.01	0.1	mA
		M, D, P, L, R, F	1		-0.01	0.1	
Off-state (high impedance) output current (3020, 3021)	IO	VCC = 5.5 V, VO = 2.5 V	1, 2, 3	All		20	μA
					M, D, P, L, R, F	1	
		VCC = 5.5 V, VO = 0.5 V	1,2,3			-20	
					M, D, P, L, R, F	1	
Input clamp voltage (3022)	VI	VCC = 4.5 V, IIN = -18 mA	1, 2, 3	All		-1.5	V
		M, D, P, L, R, F	1			-1.5	
Output short circuit current (3011)	IOS	VCC = 5.5 V <u>5/</u>	1, 2, 3	All	-30	-150	mA
		M, D, P, L, R, F	1		-30	-150	

See footnotes at end of table.

STANDARD MICROCIRCUIT DRAWING DLA LAND AND MARITIME COLUMBUS, OHIO 43218-3990	SIZE A		78023
		REVISION LEVEL U	SHEET 6

TABLE I. Electrical performance characteristics – continued.

Test (MIL-STD-883 test method)	Symbol	Conditions <u>1/</u> , <u>2/</u> -55°C ≤ TA ≤ +125°C unless otherwise specified	Group A subgroups	Device type	Limits		Unit
					Min	Max	
Power supply current (3005)	ICC	VCC = 5.5 V, all outputs disabled	1, 2, 3	01		80	mA
				02		50	
		M, D, P, L, R, F	1	01		80	
				02		50	
		VCC = 5.5 V, all outputs enabled	1, 2, 3	02		40	
				M, D, P, L, R, F	1	02	
Propagation delay, output to output	tsKEW	VCC = 5.0 V, <u>6/</u> CL = 30 pF	9	01		6.0	ns
					10, 11		
			9	02 <u>7/</u>		4.5	
					10, 11		
		VCC = 5.0 V, <u>6/</u> CL = 50 pF	9	02		6.0	
					10, 11		
			9	01		20	
					10, 11		
9	02 <u>7/</u>		15				
		10, 11		23			
VCC = 5.0 V, <u>6/</u> CL = 50 pF, see figure 3	9	02		16			
			10, 11		24		
Propagation delay, input to output (3003)	tPLH	VCC = 5.0 V, <u>6/</u> CL = 30 pF, see figure 3	9	01		20	ns
					10, 11		
			9	02 <u>7/</u>		15	
					10, 11		
		VCC = 5.0 V, <u>6/</u> CL = 50 pF, see figure 3	9	02		16	
					10, 11		
		VCC = 5.0 V <u>6/</u> CL = 30 pF, see figure 3	9	01		20	
					10, 11		
9	02 <u>7/</u>			15			
			10, 11		23		
VCC = 5.0 V <u>6/</u> CL = 50 pF, see figure 3	9	02		17			
			10, 11		25		

See footnotes at end of table.

STANDARD MICROCIRCUIT DRAWING DLA LAND AND MARITIME COLUMBUS, OHIO 43218-3990	SIZE A		78023
		REVISION LEVEL U	SHEET 7

TABLE I. Electrical performance characteristics – continued.

Test (MIL-STD-883 test method)	Symbol	Conditions <u>1/</u> , <u>2/</u> -55°C ≤ T _A ≤ +125°C unless otherwise specified	Group A subgroups	Device type	Limits		Unit	
					Min	Max		
Output disable time, ENABLE to output (3003)	tPLZ	VCC = 5.0 V <u>6/</u> CL = 10 pF, see figure 3	9	01		35	ns	
			10, 11			53		
			VCC = 5.0 V, <u>6/</u> CL = 50 pF, see figure 3	9	02 <u>7/</u>			35
				10, 11				53
			VCC = 5.0 V, <u>6/</u> CL = 50 pF, see figure 3	9	02			38
				10, 11				56
	tPHZ	VCC = 5.0 V <u>6/</u> CL = 10 pF, see figure 3	9	01		30		
			10, 11			45		
			VCC = 5.0 V, <u>6/</u> CL = 50 pF, see figure 3	9	02 <u>7/</u>			20
				10, 11				27
			VCC = 5.0 V, <u>6/</u> CL = 50 pF, see figure 3	9	02			23
				10, 11				30
Output enable time, ENABLE to output	tPZL	VCC = 5.0 V <u>6/</u> CL = 30 pF, see figure 3	9	01		45	ns	
			10, 11			68		
			VCC = 5.0 V <u>6/</u> CL = 50 pF, see figure 3	9	02 <u>7/</u>			25
				10, 11				37
			VCC = 5.0 V <u>6/</u> CL = 50 pF, see figure 3	9	02			28
				10, 11				40
	tPZH	VCC = 5.0 V <u>6/</u> CL = 30 pF, see figure 3	9	01		40		
			10, 11			60		
			VCC = 5.0 V <u>6/</u> CL = 50 pF, see figure 3	9	02 <u>7/</u>			30
				10, 11				50
			VCC = 5.0 V <u>6/</u> CL = 50 pF, see figure 3	9	02			32
				10, 11				52

See footnotes at end of table.

STANDARD MICROCIRCUIT DRAWING DLA LAND AND MARITIME COLUMBUS, OHIO 43218-3990	SIZE A		78023
		REVISION LEVEL U	SHEET 8

TABLE I. Electrical performance characteristics – continued.

- 1/ Devices supplied to this drawing will meet all levels M, D, P, L, R, F of irradiation. However, this device is only tested at the “F” level. Pre and post irradiation values are identical unless otherwise specified in table I. When performing post irradiation electrical measurements for any RHA level, $T_A = +25^\circ\text{C}$.
- 2/ These parts may be dose rate sensitive in a space environment and may demonstrate enhanced low dose rate effects. Radiation end point limits for the noted parameters are guaranteed only for the conditions specified in MIL-STD-883, method 1019, condition A.
- 3/ V_{IH} and V_{IL} tests are not required and shall be applied as forcing functions for the V_{OH} and V_{OL} tests.
- 4/ The minimum limits apply to the device classes Q and V. For device class M, these limits are not tested. The limits specified for the input low current represents the numerical range in which this parameter will pass:
device type 01: -0.36 to +0.10 and device type 02: -0.20 to +0.10.
- 5/ Not more than one output should be shorted at one time, and the duration of the short circuit condition should not exceed 1 second.
- 6/ $V_{IN} = 1.3\text{ V}$ to $V_O = 1.3\text{ V}$, $V_{PULSE} = 0\text{ V}$ to $+3.0\text{ V}$.
- 7/ This parameter is guaranteed by correlation to the testing at $CL = 50\text{ pF}$.

4. VERIFICATION

4.1 Sampling and inspection. For device classes Q and V, sampling and inspection procedures shall be in accordance with MIL-PRF-38535 or as modified in the device manufacturer's Quality Management (QM) plan. The modification in the QM plan shall not affect the form, fit, or function as described herein. For device class M, sampling and inspection procedures shall be in accordance with MIL-PRF-38535, appendix A.

4.2 Screening. For device classes Q and V, screening shall be in accordance with MIL-PRF-38535, and shall be conducted on all devices prior to qualification and technology conformance inspection. For device class M, screening shall be in accordance with method 5004 of MIL-STD-883, and shall be conducted on all devices prior to quality conformance inspection.

4.2.1 Additional criteria for device class M.

- a. Burn-in test, method 1015 of MIL-STD-883.
 - (1) Test condition A, B, C, or D. The test circuit shall be maintained by the manufacturer under document revision level control and shall be made available to the preparing or acquiring activity upon request. The test circuit shall specify the inputs, outputs, biases, and power dissipation, as applicable, in accordance with the intent specified in method 1015 of MIL-STD-883.
 - (2) $T_A = +125^\circ\text{C}$, minimum.
- b. Interim and final electrical test parameters shall be as specified in table IIA herein.

STANDARD MICROCIRCUIT DRAWING DLA LAND AND MARITIME COLUMBUS, OHIO 43218-3990	SIZE A		78023
		REVISION LEVEL U	SHEET 9

Case outlines	E, F, and Z	2
Device types	01 and 02	
Terminal number	Terminal symbol	
1	INPUT A	NC
2	OUTPUT A+	INPUT A
3	OUTPUT A-	OUTPUT A+
4	ENABLE	OUTPUT A-
5	OUTPUT B-	ENABLE
6	OUTPUT B+	NC
7	INPUT B	OUTPUT B-
8	GND	OUTPUT B+
9	INPUT C	INPUT B
10	OUTPUT C+	GND
11	OUTPUT C-	NC
12	$\overline{\text{ENABLE}}$	INPUT C
13	OUTPUT D-	OUTPUT C+
14	OUTPUT D+	OUTPUT C-
15	INPUT D	$\overline{\text{ENABLE}}$
16	VCC	NC
17	---	OUTPUT D-
18	---	OUTPUT D+
19	---	INPUT D
20	---	VCC

NC = no connection.

FIGURE 1. Terminal connections.

STANDARD MICROCIRCUIT DRAWING DLA LAND AND MARITIME COLUMBUS, OHIO 43218-3990	SIZE A		78023
		REVISION LEVEL U	SHEET 10

Case outlines E, F, and Z.

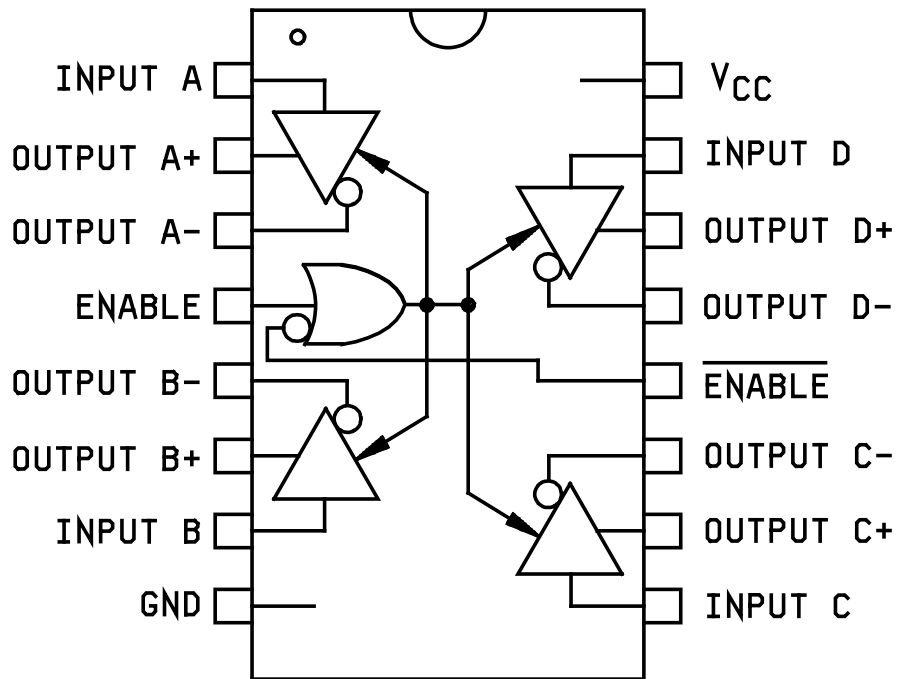

FIGURE 2. Block diagram.

**STANDARD
MICROCIRCUIT DRAWING**
DLA LAND AND MARITIME
COLUMBUS, OHIO 43218-3990

SIZE
A

78023

REVISION LEVEL
U

SHEET
11

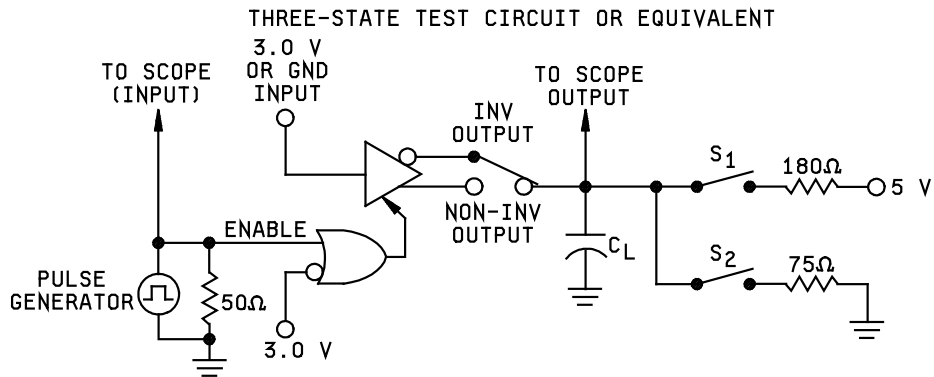
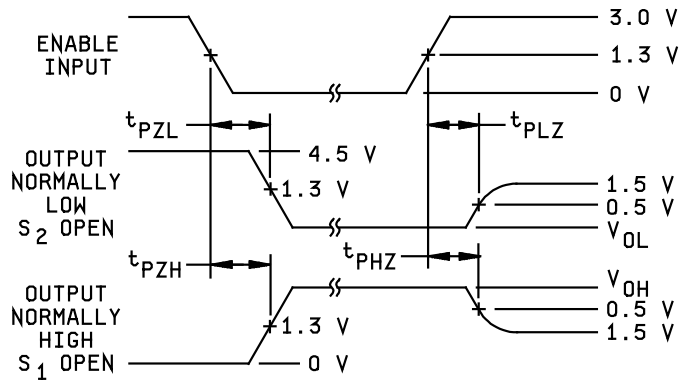
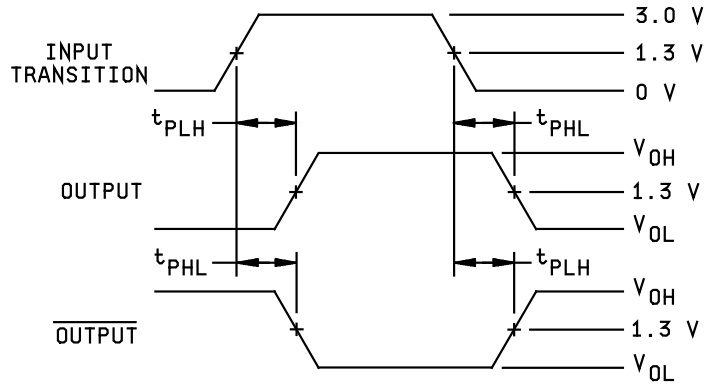

NOTE: Pulse generator characteristics:
 $Z_0 = 50\ \Omega$
 $PRR \leq 1.0\ \text{MHz}$
 $t_r, t_f \leq 6\ \text{ns}$
 C_L includes probe and jig capacitance.

FIGURE 3. Test circuit and switching waveforms.

**STANDARD
MICROCIRCUIT DRAWING**
 DLA LAND AND MARITIME
 COLUMBUS, OHIO 43218-3990

SIZE
A

78023

REVISION LEVEL
U

SHEET
12

4.2.2 Additional criteria for device classes Q and V.

- a. The burn-in test duration, test condition and test temperature, or approved alternatives shall be as specified in the device manufacturer's QM plan in accordance with MIL-PRF-38535. The burn-in test circuit shall be maintained under document revision level control of the device manufacturer's Technology Review Board (TRB) in accordance with MIL-PRF-38535 and shall be made available to the acquiring or preparing activity upon request. The test circuit shall specify the inputs, outputs, biases, and power dissipation, as applicable, in accordance with the intent specified in method 1015 of MIL-STD-883.
- b. Interim and final electrical test parameters shall be as specified in table IIA herein.
- c. Additional screening for device class V beyond the requirements of device class Q shall be as specified in MIL-PRF-38535, appendix B.

4.3 Qualification inspection for device classes Q and V. Qualification inspection for device classes Q and V shall be in accordance with MIL-PRF-38535. Inspections to be performed shall be those specified in MIL-PRF-38535 and herein for groups A, B, C, D, and E inspections (see 4.4.1 through 4.4.4).

4.4 Conformance inspection. Technology conformance inspection for classes Q and V shall be in accordance with MIL-PRF-38535 including groups A, B, C, D, and E inspections, and as specified herein. Quality conformance inspection for device class M shall be in accordance with MIL-PRF-38535, appendix A and as specified herein. Inspections to be performed for device class M shall be those specified in method 5005 of MIL-STD-883 and herein for groups A, B, C, D, and E inspections (see 4.4.1 through 4.4.4).

4.4.1 Group A inspection.

- a. Tests shall be as specified in table IIA herein.
- b. Subgroups 4, 5, 6, 7, and 8 in table I, method 5005 of MIL-STD-883 shall be omitted.

4.4.2 Group C inspection. The group C inspection end-point electrical parameters shall be as specified in table IIA herein.

4.4.2.1 Additional criteria for device class M. Steady-state life test conditions, method 1005 of MIL-STD-883:

- a. Test condition A, B, C, or D. The test circuit shall be maintained by the manufacturer under document revision level control and shall be made available to the preparing or acquiring activity upon request. The test circuit shall specify the inputs, outputs, biases, and power dissipation, as applicable, in accordance with the intent specified in method 1005 of MIL-STD-883.
- b. $T_A = +125^\circ\text{C}$, minimum.
- c. Test duration: 1,000 hours, except as permitted by method 1005 of MIL-STD-883.

4.4.2.2 Additional criteria for device classes Q and V. The steady-state life test duration, test condition and test temperature, or approved alternatives shall be as specified in the device manufacturer's QM plan in accordance with MIL-PRF-38535. The test circuit shall be maintained under document revision level control by the device manufacturer's TRB in accordance with MIL-PRF-38535 and shall be made available to the acquiring or preparing activity upon request. The test circuit shall specify the inputs, outputs, biases, and power dissipation, as applicable, in accordance with the intent specified in method 1005 of MIL-STD-883.

STANDARD MICROCIRCUIT DRAWING DLA LAND AND MARITIME COLUMBUS, OHIO 43218-3990	SIZE A		78023
		REVISION LEVEL U	SHEET 13

TABLE II. Electrical test requirements.

Test requirements	Subgroups (in accordance with MIL-STD-883, method 5005, table I)	Subgroups (in accordance with MIL-PRF-38535, table III)	
	Device class M	Device class Q	Device class V
Interim electrical parameters (see 4.2)	1	1	1
Final electrical parameters (see 4.2)	1, 2, 3, 9 <u>1/</u>	1, 2, 3, 9 <u>1/</u>	1, 2, 3, 9 <u>2/</u>
Group A test requirements (see 4.4)	1, 2, 3, 9, 10, 11 <u>3/</u>	1, 2, 3, 9, 10, 11	1, 2, 3, 9, 10, 11
Group C end-point electrical parameters (see 4.4)	1, 2, 3	1, 2, 3	1, 2, 3
Group D end-point electrical parameters (see 4.4)	1, 2, 3	1, 2, 3	1, 2, 3
Group E end-point electrical parameters (see 4.4)	1	1	1

1/ PDA applies to subgroup 1.

2/ PDA applies to subgroups 1 and delta limits. Delta limits shall be in accordance with table IIB and shall be computed with reference to the previous interim electrical parameters.

3/ Subgroups 10 and 11, if not tested, shall be guaranteed to the specified limits in table I.

TABLE IIB. Delta limits at +25°C.

Parameter <u>4/</u>	Device type	Limit
VOH	All	≤ 250 mV
VOL	All	≤ 50 mV
ICC	All	≤ 8 mA

4/ These parameters shall be read and recorded at TA = +25°C before and after each burn-in and shall not change by more than the limits indicated. The delta rejects shall be included in the PDA calculation.

**STANDARD
MICROCIRCUIT DRAWING**
DLA LAND AND MARITIME
COLUMBUS, OHIO 43218-3990

SIZE
A

78023

REVISION LEVEL
U

SHEET
14

4.4.3 Group D inspection. The group D inspection end-point electrical parameters shall be as specified in table IIA herein.

4.4.4 Group E inspection. Group E inspection is required only for parts intended to be marked as radiation hardness assured (see 3.5 herein).

- a. End-point electrical parameters shall be as specified in table IIA herein.
- b. For device classes Q and V, the devices or test vehicle shall be subjected to radiation hardness assured tests as specified in MIL-PRF-38535 for the RHA level being tested. For device class M, the devices shall be subjected to radiation hardness assured tests as specified in MIL-PRF-38535, appendix A for the RHA level being tested. All device classes must meet the postirradiation end-point electrical parameter limits as defined in table I at $T_A = +25^{\circ}\text{C} \pm 5^{\circ}\text{C}$, after exposure, to the subgroups specified in table IIA herein.

4.4.4.1 Total dose irradiation testing. Total dose irradiation testing shall be performed in accordance with MIL-STD-883 method 1019 condition A and as specified herein.

4.4.4.1.1 Accelerated annealing test. Accelerated annealing tests shall be performed on all devices requiring a RHA level greater than 5k rads(Si). The post-anneal end-point electrical parameter limits shall be as specified in table I herein and shall be the pre-irradiation end-point electrical parameter limit at $25^{\circ}\text{C} \pm 5^{\circ}\text{C}$. Testing shall be performed at initial qualification and after any design or process changes which may affect the RHA response of the device.

5. PACKAGING

5.1 Packaging requirements. The requirements for packaging shall be in accordance with MIL-PRF-38535 for device classes Q and V or MIL-PRF-38535, appendix A for device class M.

6. NOTES

6.1 Intended use. Microcircuits conforming to this drawing are intended for use for Government microcircuit applications (original equipment), design applications, and logistics purposes.

6.1.1 Replaceability. Microcircuits covered by this drawing will replace the same generic device covered by a contractor prepared specification or drawing.

6.1.2 Substitutability. Device class Q devices will replace device class M devices.

6.2 Configuration control of SMD's. All proposed changes to existing SMD's will be coordinated with the users of record for the individual documents. This coordination will be accomplished using DD Form 1692, Engineering Change Proposal.

6.3 Record of users. Military and industrial users should inform DLA Land and Maritime when a system application requires configuration control and which SMD's are applicable to that system. DLA Land and Maritime will maintain a record of users and this list will be used for coordination and distribution of changes to the drawings. Users of drawings covering microelectronic devices (FSC 5962) should contact DLA Land and Maritime-VA, telephone (614) 692-8108.

6.4 Comments. Comments on this drawing should be directed to DLA Land and Maritime-VA, Columbus, Ohio 43218-3990, or telephone (614) 692-0540.

6.5 Abbreviations, symbols, and definitions. The abbreviations, symbols, and definitions used herein are defined in MIL-PRF-38535 and MIL-HDBK-1331.

STANDARD MICROCIRCUIT DRAWING DLA LAND AND MARITIME COLUMBUS, OHIO 43218-3990	SIZE A		78023
		REVISION LEVEL U	SHEET 15

6.6 Sources of supply.

6.6.1 Sources of supply for device classes Q and V. Sources of supply for device classes Q and V are listed in MIL-HDBK-103 and QML-38535. The vendors listed in MIL-HDBK-103 and QML-38535 have submitted a certificate of compliance (see 3.6 herein) to DLA Land and Maritime-VA and have agreed to this drawing.

6.6.2 Approved sources of supply for device class M. Approved sources of supply for class M are listed in MIL-HDBK-103. The vendors listed in MIL-HDBK-103 have agreed to this drawing and a certificate of compliance (see 3.6 herein) has been submitted to and accepted by DLA Land and Maritime-VA.

6.7 Supersession data The PIN supersession data shall be as follows:

New PIN	Old PIN
5962-7802301MEA	7802301EA
5962-7802301MFA	7802301FA
5962-7802301M2A	78023012A

<p align="center">STANDARD MICROCIRCUIT DRAWING</p> <p align="center">DLA LAND AND MARITIME COLUMBUS, OHIO 43218-3990</p>	<p align="center">SIZE A</p>		<p>78023</p>
		<p align="center">REVISION LEVEL U</p>	<p>SHEET 16</p>

STANDARD MICROCIRCUIT DRAWING BULLETIN

DATE: 18-06-22

Approved sources of supply for SMD 78023 are listed below for immediate acquisition information only and shall be added to MIL-HDBK-103 and QML-38535 during the next revision. MIL-HDBK-103 and QML-38535 will be revised to include the addition or deletion of sources. The vendors listed below have agreed to this drawing and a certificate of compliance has been submitted to and accepted by DLA Land and Maritime-VA. This information bulletin is superseded by the next dated revision of MIL-HDBK-103 and QML-38535. DLA Land and Maritime maintains an online database of all current sources of supply at <https://landandmaritimeapps.dla.mil/programs/smcr/>.

Standard microcircuit drawing PIN <u>1</u> /	Vendor CAGE number	Vendor similar PIN <u>2</u> /
5962-7802301M2A	01295	AM26LS31MFKB
	3V146	26LS31/B2A
	0C7V7	QP26LS31/B2A
5962-7802301MEA	01295	AM26LS31MJB
		DS26LS31MJ-SMD
	3V146	26LS31/BEA
0C7V7	QP26LS31/BEA	
5962-7802301MFA	01295	AM26LS31MWB
	<u>3</u> /	DS26LS31MW-SMD
	3V146	26LS31/BFA
	0C7V7	QP26LS31/BFA
5962-7802301Q2A	01295	AM26LS31M
		DS26LS31ME-SMD
	0C7V7	QP26LS31/B2A
5962-7802301VEA	<u>3</u> /	DS26LS31MJ-QMLV
5962-7802301VFA	<u>3</u> /	DS26LS31MW-QMLV
5962-7802302M2A	01295	DS26F31ME/883
5962-7802302MEA	<u>3</u> /	DS26F31MJ/883
5962-7802302MFA	01295	DS26F31MW/883
5962-7802302MZA	<u>3</u> /	DS26F31MWG/883
5962-7802302VEA	<u>3</u> /	DS26F31MJ-QMLV
5962-7802302VFA	<u>3</u> /	DS26F31MW-QMLV

STANDARD MICROCIRCUIT DRAWING BULLETIN - CONTINUED

DATE: 18-06-22

Standard microcircuit drawing PIN <u>1/</u>	Vendor CAGE number	Vendor similar PIN <u>2/</u>
5962F7802301MEA	<u>3/</u>	DS26LS31MJFQML
5962F7802301MFA	<u>3/</u>	DS26LS31MWFQML
5962F7802301Q2A	<u>3/</u>	DS26LS31MEFQML
5962F7802301VEA	<u>3/</u>	DS26LS31MJFQMLV
5962F7802301VFA	<u>3/</u>	DS26LS31MWFQMLV
5962F7802302VEA	<u>3/</u>	DS26F31MJFQMLV
5962F7802302VFA	01295	DS26F31MWFQMLV
5962F7802302VZA	<u>3/</u>	DS26F31MWGFQMLV

1/ The lead finish shown for each PIN representing a hermetic package is the most readily available from the manufacturer listed for that part. If the desired lead finish is not listed contact the vendor to determine its availability.

2/ Caution. Do not use this number for item acquisition. Items acquired to this number may not satisfy the performance requirements of this drawing.

3/ Not available from an approved source of supply.

Vendor CAGE
number

Vendor name
and address

01295

Texas Instruments, Inc.
Semiconductor Group
8505 Forest Ln.
PO Box 660199
Dallas, TX 75243

0C7V7

Teledyne e2v, Inc.
765 Sycamore Drive
Milpitas, CA 95035

3V146

Rochester Electronics Inc.
16 Malcolm Hoyt Drive
Newburyport, MA 01950

The information contained herein is disseminated for convenience only and the Government assumes no liability whatsoever for any inaccuracies in the information bulletin.