

REVISIONS

| LTR | DESCRIPTION  | DATE (YR-MO-DA) | APPROVED          |
|-----|--|-----------------|-------------------|
| D   | Convert to military drawing format. Change drawing CAGE to 67268. Add vendor CAGE 34371. Delete vendor CAGE 31019. Technical and editorial changes throughout. – mbk | 91-04-12        | Michael A. Frye   |
| E   | Update boilerplate to MIL-PRF-38535 requirements. - jak  | 01-06-25        | Thomas M. Hess    |
| F   | Made change to paragraph 3.5. Update boilerplate to MIL-PRF-38535 requirements. - LTG  | 05-02-09        | Thomas M. Hess    |
| G   | Correct output current condition $I_O$ for tests $V_{OH}$ and $V_{OL}$ in table I. Change boilerplate to current MIL-PRF-38535 requirements – jak.                   | 11-07-21        | Thomas M. Hess    |
| H   | Update boilerplate paragraphs to the current MIL-PRF-38535 requirements. - LTG   | 18-05-23        | Thomas M. Hess    |
| J   | Update boilerplate paragraphs to the current MIL-PRF-38535 requirements. – RDC   | 24-10-28        | Muhammad A. Akbar |



CURRENT CAGE CODE 67268

|   |                                   |   |                           |              |   |   |   |   |   |   |    |    |   |   |  |  |  |  |  |  |
|---|-----------------------------------|---|---------------------------|--------------|---|---|---|---|---|---|----|----|---|---|--|--|--|--|--|--|
| REV   |                                   |   |                           |              |   |   |   |   |   |   |    |    |   |   |  |  |  |  |  |  |
| SHEET   |                                   |   |                           |              |   |   |   |   |   |   |    |    |   |   |  |  |  |  |  |  |
| REV   |                                   |   |                           |              |   |   |   |   |   |   |    |    |   |   |  |  |  |  |  |  |
| SHEET   |                                   |   |                           |              |   |   |   |   |   |   |    |    |   |   |  |  |  |  |  |  |
| REV STATUS  | REV                               | H   | H                         | H            | H | H | H | H | H | H | H  | H  | H | H |  |  |  |  |  |  |
| OF SHEETS   | SHEET                             | 1   | 2                         | 3            | 4 | 5 | 6 | 7 | 8 | 9 | 10 | 11 |   |   |  |  |  |  |  |  |
| PMIC N/A  | PREPARED BY<br>A. J. Foley        | <p align="center"><b>DLA LAND AND MARITIME</b><br/> <b>COLUMBUS, OHIO 43218-3990</b><br/> <a href="https://www.dla.mil/LandandMaritime">https://www.dla.mil/LandandMaritime</a></p> <p align="center">MICROCIRCUIT, DIGITAL, CMOS, DUAL BINARY<br/>                     TO 1-OF-4 DECODER/ DEMULTIPLEXER,<br/>                     MONOLITHIC SILICON</p> |                           |              |   |   |   |   |   |   |    |    |   |   |  |  |  |  |  |  |
| <p align="center"><b>STANDARD<br/>MICROCIRCUIT<br/>DRAWING</b></p> <p>THIS DRAWING IS AVAILABLE<br/>FOR USE BY ALL<br/>DEPARTMENTS<br/>AND AGENCIES OF THE<br/>DEPARTMENT OF DEFENSE</p> <p align="center">AMSC N/A</p> | CHECKED BY<br>C. R. Jackson       |   |                           |              |   |   |   |   |   |   |    |    |   |   |  |  |  |  |  |  |
|   | APPROVED BY<br>Nelson A. Hauck    |   |                           |              |   |   |   |   |   |   |    |    |   |   |  |  |  |  |  |  |
|   | DRAWING APPROVAL DATE<br>77-10-18 |   |                           |              |   |   |   |   |   |   |    |    |   |   |  |  |  |  |  |  |
|   | REVISION LEVEL<br>J               | SIZE<br>A   | CAGE CODE<br><b>14933</b> | <b>77048</b> |   |   |   |   |   |   |    |    |   |   |  |  |  |  |  |  |
|   |                                   | SHEET 1 OF 11   |                           |              |   |   |   |   |   |   |    |    |   |   |  |  |  |  |  |  |

1. SCOPE

1.1 Scope. This drawing describes device requirements for MIL-STD-883 compliant, non-JAN class level B microcircuits in accordance with MIL-PRF-38535, appendix A.

1.2 Part or Identifying Number (PIN). The complete PIN is as shown in the following example:

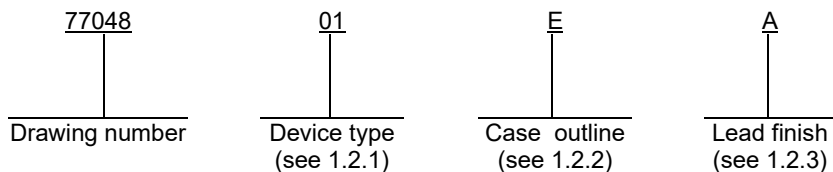

1.2.1 Device type(s). The device type(s) identify the circuit function as follows:

| <u>Device type</u> | <u>Generic number</u> | <u>Circuit function</u>                     |
|--------------------|-----------------------|---|
| 01                 | 4556B                 | Dual binary to 1-to-4 decoder/demultiplexer |

1.2.2 Case outline(s). The case outline(s) are as designated in MIL-STD-1835 and as follows:

| <u>Outline letter</u> | <u>Descriptive designator</u> | <u>Terminals</u> | <u>Package style</u> |
|-----------------------|-------------------------------|------------------|----------------------|
| E                     | GDIP1-T16 or CDIP2-T16        | 16               | Dual-in-line         |
| F                     | GDFP2-F16 or CDFP3-F16        | 16               | Flat pack            |

1.2.3 Lead finish. The lead finish is as specified in MIL-PRF-38535, appendix A.

1.3 Absolute maximum ratings.

|  |                                   |
|--|-----------------------------------|
| Supply voltage range ( $V_{DD}$ ) .....                      | -0.5 V dc to +20.0 V dc <u>1/</u> |
| Input voltage range .....                                    | -0.5 V dc to $V_{DD} + 0.5$ V dc  |
| DC input current (any one input) .....                       | $\pm 10$ mA                       |
| Storage temperature range ( $T_{STG}$ ) .....                | -65°C to +150°C                   |
| Maximum power dissipation ( $P_D$ ) .....                    | 500 mW <u>2/</u>                  |
| Lead temperature (soldering, 10 seconds) .....               | +265°C                            |
| Thermal resistance, junction-to-case ( $\theta_{JC}$ ) ..... | See MIL-STD-1835                  |
| Junction temperature ( $T_J$ ) .....                         | +175°C                            |

1.4 Recommended operating conditions.

|  |                         |
|--|-------------------------|
| Supply voltage range ( $V_{DD}$ ) .....          | +3.0 V dc to +18.0 V dc |
| Case operating temperature range ( $T_C$ ) ..... | -55°C to +125°C         |

1/ Supply voltages are referenced to  $V_{SS}$  terminal.

2/ For  $T_C = +100^\circ\text{C}$  to  $+125^\circ\text{C}$ , derate linearly at 12 mW/°C to 200 mW.

|  |                  |                     |              |
|--|------------------|---------------------|--------------|
| <b>STANDARD<br/>MICROCIRCUIT DRAWING</b><br>DLA LAND AND MARITIME<br>COLUMBUS, OHIO 43218-3990 | SIZE<br><b>A</b> |                     | <b>77048</b> |
|  |                  | REVISION LEVEL<br>J | SHEET<br>2   |

2. APPLICABLE DOCUMENTS

2.1 Government specification, standards, and handbooks. The following specification, standards, and handbooks form a part of this drawing to the extent specified herein. Unless otherwise specified, the issues of these documents are those cited in the solicitation or contract.

DEPARTMENT OF DEFENSE SPECIFICATION

MIL-PRF-38535 - Integrated Circuits, Manufacturing, General Specification for.

DEPARTMENT OF DEFENSE STANDARDS

MIL-STD-883 - Test Method Standard Microcircuits.  
MIL-STD-1835 - Interface Standard Electronic Component Case Outlines.

DEPARTMENT OF DEFENSE HANDBOOKS

MIL-HDBK-103 - List of Standard Microcircuit Drawings.  
MIL-HDBK-780 - Standard Microcircuit Drawings.

(Copies of these documents are available online at <https://quicksearch.dla.mil>).

2.2 Order of precedence. In the event of a conflict between the text of this drawing and the references cited herein, the text of this drawing takes precedence. Nothing in this document, however, supersedes applicable laws and regulations unless a specific exemption has been obtained.

3. REQUIREMENTS

3.1 Item requirements. The individual item requirements shall be in accordance with MIL-PRF-38535, appendix A for non-JAN class level B devices and as specified herein. Product built to this drawing that is produced by a Qualified Manufacturer Listing (QML) certified and qualified manufacturer or a manufacturer who has been granted transitional certification to MIL-PRF-38535 may be processed as QML product in accordance with the manufacturers approved program plan and qualifying activity approval in accordance with MIL-PRF-38535. This QML flow as documented in the Quality Management (QM) plan may make modifications to the requirements herein. These modifications shall not affect form, fit, or function of the device. These modifications shall not affect the PIN as described herein. A "Q" or "QML" certification mark in accordance with MIL-PRF-38535 is required to identify when the QML flow option is used.

3.2 Design, construction, and physical dimensions. The design, construction, and physical dimensions shall be as specified in MIL-PRF-38535, appendix A and herein.

3.2.1 Case outlines. The case outlines shall be in accordance with 1.2.2 herein.

3.2.2 Terminal connections. The terminal connections shall be as specified on figure 1.

3.2.3 Truth table. The truth table shall be as specified on figure 2.

3.2.4 Logic diagram. The logic diagram shall be as specified on figure 3.

3.2.5 Switching waveforms and test circuit. The switching waveforms and test circuit shall be as specified on figure 4.

|  |                  |                     |              |
|--|------------------|---------------------|--------------|
| <b>STANDARD<br/>MICROCIRCUIT DRAWING</b><br>DLA LAND AND MARITIME<br>COLUMBUS, OHIO 43218-3990 | SIZE<br><b>A</b> |                     | <b>77048</b> |
|  |                  | REVISION LEVEL<br>J | SHEET<br>3   |

3.3 Electrical performance characteristics. Unless otherwise specified herein, the electrical performance characteristics are as specified in table I and shall apply over the full case operating temperature range.

3.4 Electrical test requirements. The electrical test requirements shall be the subgroups specified in table II. The electrical tests for each subgroup are described in table I.

3.5 Marking. Marking shall be in accordance with MIL-PRF-38535, appendix A. The part shall be marked with the PIN listed in 1.2 herein. In addition, the manufacturer's PIN may also be marked. For packages where marking of the entire SMD PIN number is not feasible due to space limitations, the manufacturer has the option of not marking the "5962-" on the device.

3.5.1 Certification/compliance mark. A compliance indicator "C" shall be marked on all non-JAN devices built in compliance to MIL-PRF-38535, appendix A. The compliance indicator "C" shall be replaced with a "Q" or "QML" certification mark in accordance with MIL-PRF-38535 to identify when the QML flow option is used.

3.6 Certificate of compliance. A certificate of compliance shall be required from a manufacturer in order to be listed as an approved source of supply in MIL-HDBK-103 (see 6.6 herein). The certificate of compliance submitted to DLA Land and Maritime -VA prior to listing as an approved source of supply shall affirm that the manufacturer's product meets the requirements of MIL-PRF-38535, appendix A and the requirements herein.

3.7 Certificate of conformance. A certificate of conformance as required in MIL-PRF-38535, appendix A shall be provided with each lot of microcircuits delivered to this drawing.

3.8 Notification of change. Notification of change to DLA Land and Maritime -VA shall be required for any change that affects this drawing.

3.9 Verification and review. DLA Land and Maritime, DLA Land and Maritime's agent, and the acquiring activity retain the option to review the manufacturer's facility and applicable required documentation. Offshore documentation shall be made available onshore at the option of the reviewer.

|  |                  |                     |              |
|--|------------------|---------------------|--------------|
| <b>STANDARD<br/>MICROCIRCUIT DRAWING</b><br>DLA LAND AND MARITIME<br>COLUMBUS, OHIO 43218-3990 | SIZE<br><b>A</b> |                     | <b>77048</b> |
|  |                  | REVISION LEVEL<br>J | SHEET<br>4   |

TABLE I. Electrical performance characteristics.

| Test                      | Symbol          | Test conditions<br>-55°C ≤ T <sub>C</sub> ≤ +125°C<br>unless otherwise specified                            |  | Group A<br>subgroups                | Limits |       | Unit |
|---------------------------|-----------------|---|--|-------------------------------------|--------|-------|------|
|                           |                 |   |  |                                     | Min    | Max   |      |
| Quiescent supply current  | I <sub>DD</sub> | V <sub>DD</sub> = 5.0 V <u>1</u> /<br>V <sub>IN</sub> = 0.0 V or V <sub>DD</sub>                            |  | 1, 3                                |        | 5.0   | μA   |
|                           |                 |   |  | 2                                   |        | 150.0 |      |
|                           |                 | V <sub>DD</sub> = 10.0 V <u>1</u> /<br>V <sub>IN</sub> = 0.0 V or V <sub>DD</sub>                           |  | 1, 3                                |        | 10.0  |      |
|                           |                 |   |  | 2                                   |        | 300.0 |      |
|                           |                 | V <sub>DD</sub> = 15.0 V <u>1</u> /<br>V <sub>IN</sub> = 0.0 V or V <sub>DD</sub>                           |  | 1, 3                                |        | 20.0  |      |
|                           |                 |   |  | 2                                   |        | 600.0 |      |
|                           |                 | V <sub>DD</sub> = 20.0 V <u>2</u> /<br>V <sub>IN</sub> = 0.0 V or V <sub>DD</sub>                           |  | 1, 3                                |        | 100.0 |      |
|                           |                 |   |  | 2                                   |        | 3.0   |      |
| Low-level output voltage  | V <sub>OL</sub> | V <sub>IN</sub> = 0.0 V or V <sub>DD</sub><br>I <sub>OL</sub> = +1.0 μA                                     |  | V <sub>DD</sub> = 5.0 V <u>1</u> /  |        | 0.05  | V    |
|                           |                 |   |  | V <sub>DD</sub> = 10.0 V <u>1</u> / |        | 0.05  |      |
|                           |                 |   |  | V <sub>DD</sub> = 15.0 V            |        | 0.05  |      |
| High-level output voltage | V <sub>OH</sub> | V <sub>IN</sub> = 0.0 V or V <sub>DD</sub><br>I <sub>OH</sub> = -1.0 μA                                     |  | V <sub>DD</sub> = 5.0 V <u>1</u> /  | 4.95   |       | V    |
|                           |                 |   |  | V <sub>DD</sub> = 10.0 V <u>1</u> / | 9.95   |       |      |
|                           |                 |   |  | V <sub>DD</sub> = 15.0 V            | 14.95  |       |      |
| Low-level input voltage   | V <sub>IL</sub> | V <sub>DD</sub> = 5.0 V<br>V <sub>O</sub> = 0.5 V or 4.5 V  |  | 1, 2, 3                             |        | 1.5   | V    |
|                           |                 | V <sub>DD</sub> = 10.0 V<br>V <sub>O</sub> = 1.0 V or 9.0 V <u>1</u> /                                      |  | 1, 2, 3                             |        | 3.0   |      |
|                           |                 | V <sub>DD</sub> = 15.0 V<br>V <sub>O</sub> = 1.5 V or 13.5 V  |  | 1, 2, 3                             |        | 4.0   |      |
| High-level input voltage  | V <sub>IH</sub> | V <sub>DD</sub> = 5.0 V<br>V <sub>O</sub> = 0.5 V or 4.5 V  |  | 1, 2, 3                             | 3.5    |       | V    |
|                           |                 | V <sub>DD</sub> = 10.0 V<br>V <sub>O</sub> = 1.0 V or 9.0 V <u>1</u> /                                      |  | 1, 2, 3                             | 7.0    |       |      |
|                           |                 | V <sub>DD</sub> = 15.0 V<br>V <sub>O</sub> = 1.5 V or 13.5 V  |  | 1, 2, 3                             | 11.0   |       |      |
| Low-level output current  | I <sub>OL</sub> | V <sub>DD</sub> = 5.0 V <u>3</u> /<br>V <sub>O</sub> = 0.4 V<br>V <sub>IN</sub> = 0.0 V or V <sub>DD</sub>  |  | 1                                   | 0.51   |       | mA   |
|                           |                 |   |  | 2                                   | 0.36   |       |      |
|                           |                 |   |  | 3                                   | 0.64   |       |      |
|                           |                 | V <sub>DD</sub> = 10.0 V <u>1</u> /<br>V <sub>O</sub> = 0.5 V<br>V <sub>IN</sub> = 0.0 V or V <sub>DD</sub> |  | 1                                   | 1.3    |       |      |
|                           |                 |   |  | 2                                   | 0.9    |       |      |
|                           |                 |   |  | 3                                   | 1.6    |       |      |
|                           |                 | V <sub>DD</sub> = 15.0 V <u>1</u> /<br>V <sub>O</sub> = 1.5 V<br>V <sub>IN</sub> = 0.0 V or V <sub>DD</sub> |  | 1                                   | 3.4    |       |      |
|                           |                 |   |  | 2                                   | 2.4    |       |      |
|                           |                 |   |  | 3                                   | 4.2    |       |      |

See footnotes at end of table.

**STANDARD  
MICROCIRCUIT DRAWING**  
DLA LAND AND MARITIME  
COLUMBUS, OHIO 43218-3990

SIZE  
**A**

**77048**

REVISION LEVEL  
**J**

SHEET  
**5**

TABLE I. Electrical performance characteristics - Continued.

| Test  | Symbol                                   | Test conditions<br>-55°C ≤ T <sub>C</sub> ≤ +125°C<br>unless otherwise specified                             | Group A<br>subgroups               | Limits |      | Unit |    |
|---|--|--|------------------------------------|--------|------|------|----|
|   |  |  |                                    | Min    | Max  |      |    |
| High-level output<br>current  | I <sub>OH</sub>                          | V <sub>DD</sub> = 5.0 V <u>3/</u><br>V <sub>O</sub> = 4.6 V<br>V <sub>IN</sub> = 0.0 V or V <sub>DD</sub>    | 1                                  | -0.51  |      | mA   |    |
|   |  |  | 2                                  | -0.36  |      |      |    |
|   |  |  | 3                                  | -0.64  |      |      |    |
|   |  | V <sub>DD</sub> = 5.0 V <u>3/</u><br>V <sub>O</sub> = 2.5 V<br>V <sub>IN</sub> = 0.0 V or V <sub>DD</sub>    | 1                                  | -1.6   |      |      |    |
|   |  |  | 2                                  | -1.15  |      |      |    |
|   |  |  | 3                                  | -2.0   |      |      |    |
|   |  | V <sub>DD</sub> = 10.0 V <u>1/</u><br>V <sub>O</sub> = 9.5 V<br>V <sub>IN</sub> = 0.0 V or V <sub>DD</sub>   | 1                                  | -1.3   |      |      |    |
|   |  |  | 2                                  | -0.9   |      |      |    |
|   |  |  | 3                                  | -1.60  |      |      |    |
|   |  | V <sub>DD</sub> = 15.0 V <u>1/</u><br>V <sub>O</sub> = 13.5 V<br>V <sub>IN</sub> = 0.0 V or V <sub>DD</sub>  | 1                                  | -3.4   |      |      |    |
|   |  |  | 2                                  | -2.4   |      |      |    |
|   |  |  | 3                                  | -4.2   |      |      |    |
| Input current   | I <sub>IN</sub>                          | V <sub>DD</sub> = 18.0 V <u>2/</u><br>V <sub>IN</sub> = 0.0 V or V <sub>DD</sub>                             | 1, 3                               |        | ±0.1 | μA   |    |
|   |  |  | 2                                  |        | ±1.0 |      |    |
| Input capacitance   | C <sub>IN</sub>                          | V <sub>IN</sub> = 0.0 V, See 4.3.1c  | 4                                  |        | 7.5  | pF   |    |
| Functional test   |  | See 4.3.1d   | 7, 8                               |        |      |      |    |
| Transition time   | t <sub>THL</sub> ,<br>t <sub>TLH</sub>   | R <sub>L</sub> = 200 kΩ<br>C <sub>L</sub> = 50 pF<br>t <sub>r</sub> = t <sub>f</sub> = 20 ns<br>See figure 4 | V <sub>DD</sub> = 5.0 V            | 9      | 1.5  | 200  | ns |
|   |  |  |                                    | 10, 11 | 1.5  | 300  |    |
|   |  |  | V <sub>DD</sub> = 10.0 V <u>1/</u> | 9      | 1.5  | 100  |    |
|   |  |  |                                    | 10, 11 | 1.5  | 150  |    |
|   |  |  | V <sub>DD</sub> = 15.0 V <u>1/</u> | 9      | 1.5  | 80   |    |
|   |  |  |                                    | 10, 11 | 1.5  | 120  |    |
| Propagation delay<br>time, A <sub>n</sub> to Q <sub>mn</sub> ,<br>B <sub>n</sub> to Q <sub>mn</sub> | t <sub>PHL1</sub> ,<br>t <sub>PLH1</sub> | R <sub>L</sub> = 200 kΩ<br>C <sub>L</sub> = 50 pF<br>t <sub>r</sub> = t <sub>f</sub> = 20 ns<br>See figure 4 | V <sub>DD</sub> = 5.0 V            | 9      | 1.5  | 440  | ns |
|   |  |  |                                    | 10, 11 | 1.5  | 660  |    |
|   |  |  | V <sub>DD</sub> = 10.0 V <u>1/</u> | 9      | 1.5  | 190  |    |
|   |  |  |                                    | 10, 11 | 1.5  | 285  |    |
|   |  |  | V <sub>DD</sub> = 15.0 V <u>1/</u> | 9      | 1.5  | 140  |    |
|   |  |  |                                    | 10, 11 | 1.5  | 210  |    |
| Propagation delay<br>time, E <sub>n</sub> to Q <sub>mn</sub>  | t <sub>PHL2</sub> ,<br>t <sub>PLH2</sub> | R <sub>L</sub> = 200 kΩ<br>C <sub>L</sub> = 50 pF<br>t <sub>r</sub> = t <sub>f</sub> = 20 ns<br>See figure 4 | V <sub>DD</sub> = 5.0 V            | 9      | 1.5  | 400  | ns |
|   |  |  |                                    | 10, 11 | 1.5  | 600  |    |
|   |  |  | V <sub>DD</sub> = 10.0 V <u>1/</u> | 9      | 1.5  | 170  |    |
|   |  |  |                                    | 10, 11 | 1.5  | 255  |    |
|   |  |  | V <sub>DD</sub> = 15.0 V <u>1/</u> | 9      | 1.5  | 130  |    |
|   |  |  |                                    | 10, 11 | 1.5  | 195  |    |

1/ This parameter is guaranteed, if not tested, to the limits specified in table I.

2/ This test is performed with V<sub>DD</sub> = 18 V at T<sub>C</sub> = -55°C.

3/ The I<sub>OL</sub> and I<sub>OH</sub> tests are tested 100 percent at T<sub>C</sub> = +25°C, and are guaranteed, if not tested, for T<sub>C</sub> = -55°C and T<sub>C</sub> = +125°C.

**STANDARD  
MICROCIRCUIT DRAWING**  
DLA LAND AND MARITIME  
COLUMBUS, OHIO 43218-3990

SIZE  
**A**

**77048**

REVISION LEVEL  
**J**

SHEET  
**6**

|                 |                  |
|-----------------|------------------|
| Device type     | 01               |
| Case outlines   | E and F          |
| Terminal number | Terminal symbol  |
| 1               | $\overline{EA}$  |
| 2               | AA               |
| 3               | BA               |
| 4               | $\overline{Q0A}$ |
| 5               | $\overline{Q1A}$ |
| 6               | $\overline{Q2A}$ |
| 7               | $\overline{Q3A}$ |
| 8               | V <sub>SS</sub>  |
| 9               | $\overline{Q3B}$ |
| 10              | $\overline{Q2B}$ |
| 11              | $\overline{Q1B}$ |
| 12              | $\overline{Q0B}$ |
| 13              | B <sub>B</sub>   |
| 14              | A <sub>B</sub>   |
| 15              | $\overline{EB}$  |
| 16              | V <sub>DD</sub>  |

| Pin descriptions                           |                                 |
|--|---------------------------------|
| $\overline{En}$ (n = A or B)               | Enable inputs (active low)      |
| A <sub>n</sub> (n = A or B)                | Data inputs                     |
| B <sub>n</sub> (n = A or B)                | Data inputs                     |
| $\overline{Qmn}$ (m = 0 to 3) (n = A or B) | Data outputs (inverted outputs) |

FIGURE 1. Terminal connections.

|  |                  |                     |              |
|--|------------------|---------------------|--------------|
| <b>STANDARD<br/>MICROCIRCUIT DRAWING</b><br>DLA LAND AND MARITIME<br>COLUMBUS, OHIO 43218-3990 | SIZE<br><b>A</b> |                     | <b>77048</b> |
|  |                  | REVISION LEVEL<br>J | SHEET<br>7   |

| Inputs           |         |       | Outputs           |                   |                   |                   |
|------------------|---------|-------|-------------------|-------------------|-------------------|-------------------|
| $\overline{E}_n$ | Selects |       | $\overline{Q3}_n$ | $\overline{Q2}_n$ | $\overline{Q1}_n$ | $\overline{Q0}_n$ |
|                  | $B_n$   | $A_n$ |                   |                   |                   |                   |
| L                | L       | L     | H                 | H                 | H                 | L                 |
| L                | L       | H     | H                 | H                 | L                 | H                 |
| L                | H       | L     | H                 | L                 | H                 | H                 |
| L                | H       | H     | L                 | H                 | H                 | H                 |
| H                | X       | X     | H                 | H                 | H                 | H                 |

H = High voltage level  
L = Low voltage level  
X = Irrelevant

FIGURE 2. Truth table.

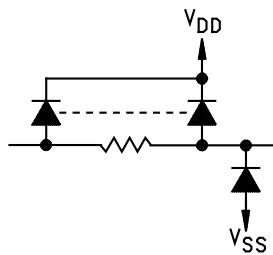
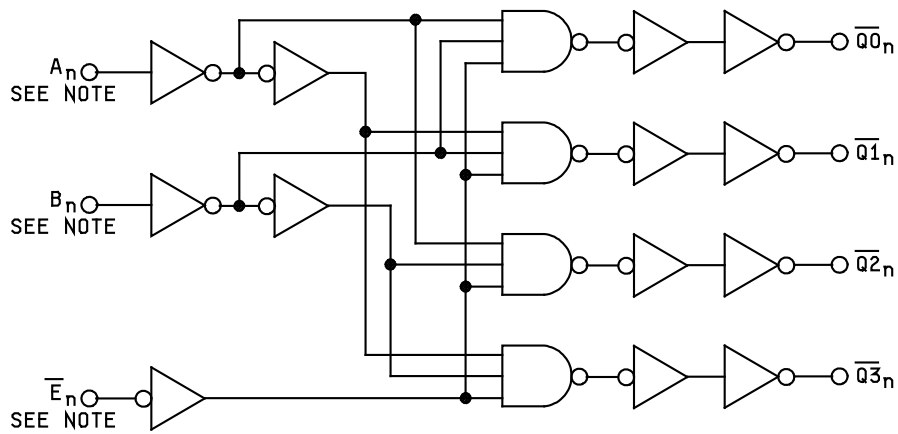

NOTE: All inputs are protected by a CMOS protection network as shown above.

FIGURE 3. Logic diagram.

**STANDARD  
MICROCIRCUIT DRAWING**  
DLA LAND AND MARITIME  
COLUMBUS, OHIO 43218-3990

SIZE  
**A**

**77048**

REVISION LEVEL  
**J**

SHEET  
**8**



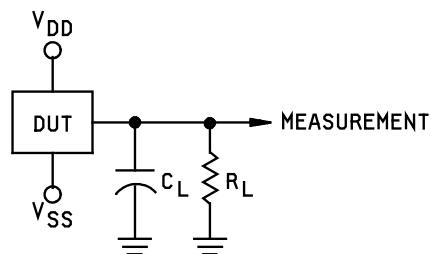
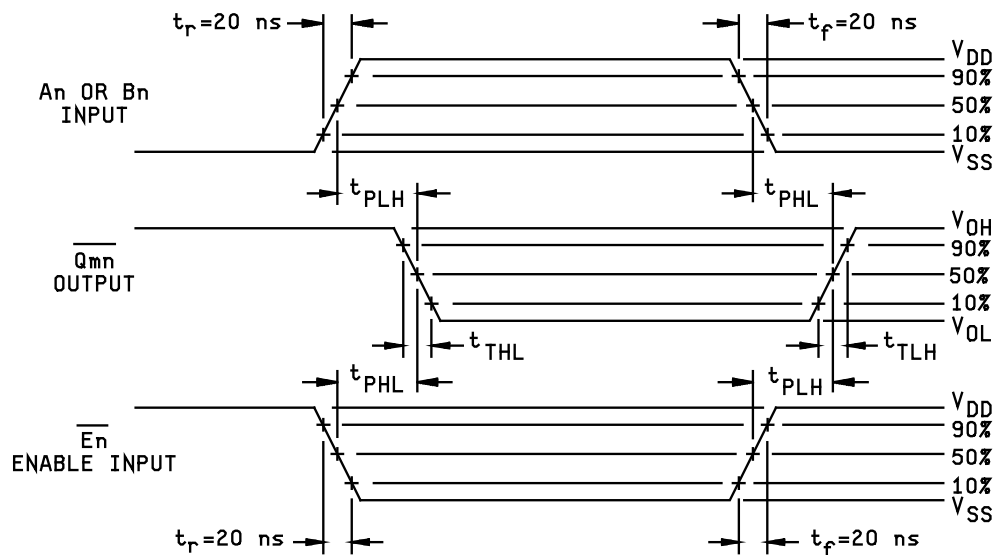

NOTES:

1.  $C_L = 50 \text{ pF} \pm 5\%$  (including wiring and probe capacitance)
2.  $R_L = 200 \text{ k}\Omega \pm 5\%$
3.  $t_r, t_f = 20 \text{ ns}$ .

FIGURE 4. Switching waveforms and test circuit.

**STANDARD  
MICROCIRCUIT DRAWING**  
DLA LAND AND MARITIME  
COLUMBUS, OHIO 43218-3990

SIZE  
**A**

**77048**

REVISION LEVEL  
J

SHEET  
9

4. VERIFICATION

4.1 Sampling and inspection. Sampling and inspection procedures shall be in accordance with MIL-PRF-38535, appendix A.

4.2 Screening. Screening shall be in accordance with method 5004 of MIL-STD-883, and shall be conducted on all devices prior to quality conformance inspection. The following additional criteria shall apply:

- a. Burn-in test, method 1015 of MIL-STD-883.
  - (1) Test condition A, B, C, or D. The test circuit shall be maintained by the manufacturer under document revision level control and shall be made available to the preparing or acquiring activity upon request. The test circuit shall specify the inputs, outputs, biases, and power dissipation, as applicable, in accordance with the intent specified in method 1015 of MIL-STD-883.
  - (2)  $T_A = +125^{\circ}\text{C}$ , minimum.
- b. Interim and final electrical test parameters shall be as specified in table II herein, except interim electrical parameter tests prior to burn-in are optional at the discretion of the manufacturer.

TABLE II. Electrical test requirements.

| MIL-STD-883 test requirements                                      | Subgroups<br>(in accordance with<br>MIL-STD-883, method 5005,<br>table I) |
|--|---|
| Interim electrical parameters<br>(method 5004)                     | ---   |
| Final electrical test parameters<br>(method 5004)                  | 1, 2, 3, 7, 8, 9 <u>1/</u>  |
| Group A test requirements<br>(method 5005)                         | 1, 2, 3, 4, 7, 8, 9, 10, 11 <u>2/</u>                                     |
| Groups C and D end-point<br>electrical parameters<br>(method 5005) | 1, 2, 3   |

1/ PDA applies to subgroup 1.

2/ Subgroups 10 and 11, if not tested, shall be guaranteed to the specified limits in table I.

4.3 Quality conformance inspection. Quality conformance inspection shall be in accordance with method 5005 of MIL-STD-883 including groups A, B, C, and D inspections. The following additional criteria shall apply.

4.3.1 Group A inspection.

- a. Tests shall be as specified in table II herein.
- b. Subgroups 5 and 6 in table I, method 5005 of MIL-STD-883 shall be omitted.
- c. Subgroup 4 ( $C_{IN}$  measurement) shall be measured only for the initial test and after process or design changes which may affect input capacitance. Capacitance shall be measured between the designated terminal and  $V_{SS}$  at a frequency of 1 MHz. Test all applicable pins on 5 devices with zero failures.
- d. Subgroups 7 and 8 shall include verification of the truth table as specified on figure 2.

|  |                  |                     |              |
|--|------------------|---------------------|--------------|
| <b>STANDARD<br/>MICROCIRCUIT DRAWING</b><br>DLA LAND AND MARITIME<br>COLUMBUS, OHIO 43218-3990 | SIZE<br><b>A</b> |                     | <b>77048</b> |
|  |                  | REVISION LEVEL<br>J | SHEET<br>10  |

4.3.2 Groups C and D inspections.

- a. End-point electrical parameters shall be as specified in table II herein.
- b. Steady-state life test conditions, method 1005 of MIL-STD-883.
  - (1) Test condition A, B, C, or D. The test circuit shall be maintained by the manufacturer under document revision level control and shall be made available to the preparing or acquiring activity upon request. The test circuit shall specify the inputs, outputs, biases, and power dissipation, as applicable, in accordance with the intent specified in method 1005 of MIL-STD-883.
  - (2)  $T_A = +125^{\circ}\text{C}$ , minimum.
  - (3) Test duration: 1,000 hours, except as permitted by method 1005 of MIL-STD-883.

5. PACKAGING

5.1 Packaging requirements. The requirements for packaging shall be in accordance with MIL-PRF-38535, appendix A.

6. NOTES

6.1 Intended use. Microcircuits conforming to this drawing are intended for use for Government microcircuit applications (original equipment), design applications, and logistics purposes.

6.2 Replaceability. Microcircuits covered by this drawing will replace the same generic device covered by a contractor-prepared specification or drawing.

6.3 Configuration control of SMD's. All proposed changes to existing SMD's will be coordinated with the users of record for the individual documents. This coordination will be accomplished using DD Form 1692, Engineering Change Proposal or email communication.

6.4 Record of users. Military and industrial users shall inform DLA Land and Maritime when a system application requires configuration control and the applicable SMD to that system. DLA Land and Maritime will maintain a record of users and this list will be used for coordination and distribution of changes to the drawings. Users of drawings covering microelectronics devices (FSC 5962) should contact DLA Land and Maritime-VA, telephone (614) 692-8108.

6.5 Comments. Comments on this drawing should be directed to DLA Land and Maritime-VA, Columbus, Ohio 43218-3990, or telephone (614) 692-0591.

6.6 Approved sources of supply. Approved sources of supply are listed in MIL-HDBK-103 and QML-38535. The vendors listed in MIL-HDBK-103 and QML-38535 have agreed to this drawing and a certificate of compliance (see 3.6 herein) has been submitted to and accepted by DLA Land and Maritime-VA.

|  |                  |                     |              |
|--|------------------|---------------------|--------------|
| <b>STANDARD<br/>MICROCIRCUIT DRAWING</b><br>DLA LAND AND MARITIME<br>COLUMBUS, OHIO 43218-3990 | SIZE<br><b>A</b> |                     | <b>77048</b> |
|  |                  | REVISION LEVEL<br>J | SHEET<br>11  |

STANDARD MICROCIRCUIT DRAWING BULLETIN

DATE: 24-10-28

Approved sources of supply for SMD 77048 are listed below for immediate acquisition information only and shall be added to MIL-HDBK-103 and QML-38535 during the next revision. MIL-HDBK-103 and QML-38535 will be revised to include the addition or deletion of sources. The vendors listed below have agreed to this drawing and a certificate of compliance has been submitted to and accepted by DLA Land and Maritime-VA. This information bulletin is superseded by the next dated revision of MIL-HDBK-103 and QML-38535. DLA Land and Maritime maintains an online database of all current sources of supply at: <https://landandmaritimeapps.dla.mil/programs/smcr/>

| Standard microcircuit drawing<br>PIN <u>1/</u> | Vendor CAGE<br>number | Vendor similar<br>PIN <u>2/</u> |
|--|-----------------------|---------------------------------|
| 7704801EA                                      | 01295                 | CD4556BF3A                      |
| 7704801FA                                      | <u>3/</u>             | 4556BFMQB                       |

1/ The lead finish shown for each PIN representing a hermetic package is the most readily available from the manufacturer listed for that part. If the desired lead finish is not listed contact the vendor to determine its availability.

2/ Caution. Do not use this number for item acquisition. Items acquired to this number may not satisfy the performance requirements of this drawing.

3/ Not available from an approved source of supply.

Vendor CAGE  
number

01295

Vendor name  
and address

Texas Instruments Inc.  
12500 TI Blvd  
Dallas, TX 75243

The information contained herein is disseminated for convenience only and the Government assumes no liability whatsoever for any inaccuracies in the information bulletin.