

REVISIONS

LTR	DESCRIPTION	DATE (YR-MO-DA)	APPROVED
F	Convert to military drawing format. Delete vendor CAGE number 27014. Table I, change tPHL1 (CL = 50 pF for subgroup 9) from 23 ns to 24 ns (subgroups 10 and 11) from 31 ns to 33 ns. Change tPLH2 to tPLH1 and tPHL3 to tPHL2. Add LCC, outline letter 2 to case outlines (make editorial changes pertaining to this). Change CAGE code to 67268.	87-10-09	R. P. Evans
G	Update to reflect latest changes in format and requirements. Editorial changes throughout. --les	03-03-20	Raymond Monnin
H	Update to reflect latest changes in format and requirements. Correct paragraph in 3.5. Editorial changes throughout. --les	05-08-02	Raymond Monnin
J	Update drawing to current MIL-PRF-38535 requirements. -jt	17-06-16	Charles Saffle

THE ORIGINAL FIRST PAGE OF THIS DRAWING HAS BEEN REPLACED.

**CURRENT CAGE CODE 67268**



REV																				
SHEET																				
REV																				
SHEET																				

REV STATUS	REV	J	J	J	J	J	J	J	J	J	J									
OF SHEETS	SHEET	1	2	3	4	5	6	7	8	9										

PMIC N/A	PREPARED BY Monica L. Grosel	<p align="center"><b>DLA LAND AND MARITIME</b>  <b>COLUMBUS, OHIO 43218-3990</b>  <a href="http://www.landandmaritime.dla.mil">http://www.landandmaritime.dla.mil</a></p> <p align="center"><b>MICROCIRCUIT, DIGITAL, BIPOLAR, LOW-POWER SCHOTTKY TTL, LATCH, MONOLITHIC SILICON</b></p>																	
<p align="center"><b>STANDARD MICROCIRCUIT DRAWING</b></p> <p>THIS DRAWING IS AVAILABLE FOR USE BY ALL DEPARTMENTS AND AGENCIES OF THE DEPARTMENT OF DEFENSE</p> <p align="center">AMSC N/A</p>	CHECKED BY D. A. DiCenzo																		
	APPROVED BY Robert P. Evans																		
	DRAWING APPROVAL DATE 76-03-23																		
	REVISION LEVEL J	SIZE A	CAGE CODE <b>14933</b>	<b>76018</b>															
		SHEET		1 OF 9															

1. SCOPE

1.1 Scope. This drawing describes device requirements for MIL-STD-883 compliant, non-JAN class level B microcircuits in accordance with MIL-PRF-38535, appendix A.

1.2 Part or Identifying Number (PIN). The complete PIN is as shown in the following example:

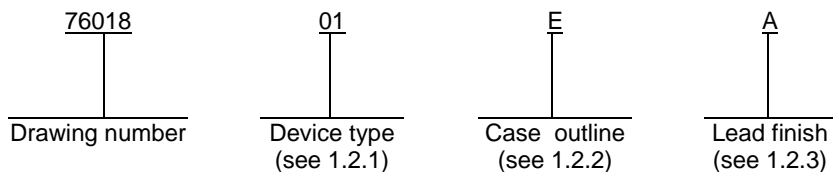

1.2.1 Device type. The device types identify the circuit function as follows:

<u>Device type</u>	<u>Generic number</u>	<u>Circuit function</u>
01	54LS279	Quadruple $\bar{S}$ - $\bar{R}$ latches

1.2.2 Case outlines. The case outlines are as designated in MIL-STD-1835 and as follows:

<u>Outline letter</u>	<u>Descriptive designator</u>	<u>Terminals</u>	<u>Package style</u>
E	GDIP1-T16 or CDIP2-T16	16	dual-in-line
F	GDFP2-F16 or CDFP3-F16	16	flat
2	CQCC1-N20	20	square chip carrier

1.2.3 Lead finish. The lead finish is as specified in MIL-PRF-38535, appendix A.

1.3 Absolute maximum ratings.

Supply voltage .....	-0.5 V dc to +7.0 V dc
Input voltage range .....	-1.5 V dc at -18 mA to +5.5 V dc
Storage temperature range .....	-65°C to +150°C
Maximum power dissipation ( $P_D$ ) <sup>1/</sup> .....	38 mW
Lead temperature (soldering, 10 seconds) .....	+300°C
Thermal resistance, junction-to-case ( $\theta_{JC}$ ): .....	See MIL-STD-1835
Junction temperature ( $T_J$ ) .....	+175°C

1.4 Recommended operating conditions.

Supply voltage range ( $V_{CC}$ ) .....	4.5 V dc to 5.5 V dc
Minimum high level input voltage ( $V_{IH}$ ) .....	2.0 V dc
Maximum low level input voltage ( $V_{IL}$ ) .....	0.7 V dc
Case operating temperature range ( $T_C$ ) .....	-55°C to +125°C

<sup>1/</sup> Maximum power dissipation is defined as  $V_{CC} \times I_{CC}$ , and must withstand the added  $P_D$  due to short-circuit test; e.g.,  $I_{OS}$ .

<b>STANDARD MICROCIRCUIT DRAWING</b> DLA LAND AND MARITIME COLUMBUS, OHIO 43218-3990	SIZE <b>A</b>		<b>76018</b>
		REVISION LEVEL <b>J</b>	SHEET <b>2</b>

2. APPLICABLE DOCUMENTS

2.1 Government specification, standards, and handbooks. The following specification, standards, and handbooks form a part of this drawing to the extent specified herein. Unless otherwise specified, the issues of these documents are those cited in the solicitation or contract.

DEPARTMENT OF DEFENSE SPECIFICATION

MIL-PRF-38535 - Integrated Circuits, Manufacturing, General Specification for.

DEPARTMENT OF DEFENSE STANDARDS

MIL-STD-883 - Test Method Standard Microcircuits.  
MIL-STD-1835 - Interface Standard Electronic Component Case Outlines.

DEPARTMENT OF DEFENSE HANDBOOKS

MIL-HDBK-103 - List of Standard Microcircuit Drawings.  
MIL-HDBK-780 - Standard Microcircuit Drawings.

(Copies of these documents are available online at <http://quicksearch.dla.mil/> or from the Standardization Document Order Desk, 700 Robbins Avenue, Building 4D, Philadelphia, PA 19111-5094.)

2.2 Order of precedence. In the event of a conflict between the text of this drawing and the references cited herein, the text of this drawing takes precedence. Nothing in this document, however, supersedes applicable laws and regulations unless a specific exemption has been obtained.

3. REQUIREMENTS

3.1 Item requirements. The individual item requirements shall be in accordance with MIL-PRF-38535, appendix A for non-JAN class level B devices and as specified herein. Product built to this drawing that is produced by a Qualified Manufacturer Listing (QML) certified and qualified manufacturer or a manufacturer who has been granted transitional certification to MIL-PRF-38535 may be processed as QML product in accordance with the manufacturers approved program plan and qualifying activity approval in accordance with MIL-PRF-38535. This QML flow as documented in the Quality Management (QM) plan may make modifications to the requirements herein. These modifications shall not affect form, fit, or function of the device. These modifications shall not affect the PIN as described herein. A "Q" or "QML" certification mark in accordance with MIL-PRF-38535 is required to identify when the QML flow option is used.

3.2 Design, construction, and physical dimensions. The design, construction, and physical dimensions shall be as specified in MIL-PRF-38535, appendix A and herein.

3.2.1 Case outlines. The case outlines shall be in accordance with 1.2.2 herein.

3.2.2 Terminal connections. The terminal connections shall be as specified on figure 1.

3.2.3 Truth table. The truth tables shall be as specified on figure 2.

3.2.4 Logic diagram. The logic diagram shall be as specified on figure 3.

3.3 Electrical performance characteristics. Unless otherwise specified herein, the electrical performance characteristics are as specified in table I and shall apply over the full case operating temperature range.

<b>STANDARD MICROCIRCUIT DRAWING</b> DLA LAND AND MARITIME COLUMBUS, OHIO 43218-3990	SIZE <b>A</b>		<b>76018</b>
		REVISION LEVEL <b>J</b>	SHEET <b>3</b>

3.4 Electrical test requirements. The electrical test requirements shall be the subgroups specified in table II. The electrical tests for each subgroup are described in table I.

3.5 Marking. Marking shall be in accordance with MIL-PRF-38535, appendix A. The part shall be marked with the PIN listed in 1.2 herein. In addition, the manufacturer's PIN may also be marked.

3.5.1 Certification/compliance mark. A compliance indicator "C" shall be marked on all non-JAN devices built in compliance to MIL-PRF-38535, appendix A. The compliance indicator "C" shall be replaced with a "Q" or "QML" certification mark in accordance with MIL-PRF-38535 to identify when the QML flow option is used.

3.6 Certificate of compliance. A certificate of compliance shall be required from a manufacturer in order to be listed as an approved source of supply in MIL-HDBK-103 (see 6.6 herein). The certificate of compliance submitted to DLA Land and Maritime -VA prior to listing as an approved source of supply shall affirm that the manufacturer's product meets the requirements of MIL-PRF-38535, appendix A and the requirements herein.

3.7 Certificate of conformance. A certificate of conformance as required in MIL-PRF-38535, appendix A shall be provided with each lot of microcircuits delivered to this drawing.

3.8 Notification of change. Notification of change to DLA Land and Maritime -VA shall be required for any change that affects this drawing.

3.9 Verification and review. DLA Land and Maritime, DLA Land and Maritime's agent, and the acquiring activity retain the option to review the manufacturer's facility and applicable required documentation. Offshore documentation shall be made available onshore at the option of the reviewer.

**STANDARD  
MICROCIRCUIT DRAWING**  
DLA LAND AND MARITIME  
COLUMBUS, OHIO 43218-3990

SIZE  
**A**

**76018**

REVISION LEVEL  
**J**

SHEET  
**4**

TABLE I. Electrical performance characteristics.

Test	Symbol	Conditions -55°C ≤ T <sub>c</sub> ≤ +125°C unless otherwise specified		Group A subgroups	Device type	Limits		Unit
						Min	Max	
High level output voltage	V <sub>OH</sub>	V <sub>CC</sub> = 4.5 V, I <sub>OH</sub> = -0.4 mA, V <sub>IL</sub> = 0.7 V, V <sub>IH</sub> = 2.0 V		1, 2, 3	All	2.5		V
Low level output voltage	V <sub>OL</sub>	V <sub>CC</sub> = 4.5 V, I <sub>OL</sub> = 4.0 mA, V <sub>IN</sub> = 0.7 V, V <sub>IH</sub> = 2.0 V		1, 2, 3	All		0.4	V
Input clamp voltage	V <sub>IC</sub>	V <sub>CC</sub> = 4.5 V, I <sub>IN</sub> = -18 mA		1	All		-1.5	V
High level input current	I <sub>IH1</sub>	V <sub>CC</sub> = 5.5 V, V <sub>IH</sub> = 2.7 V		1, 2, 3	All		20	μA
	I <sub>IH2</sub>	V <sub>CC</sub> = 5.5 V, V <sub>IH</sub> = 5.5 V		1, 2, 3	All		100	μA
Low level input current	I <sub>IL</sub>	V <sub>CC</sub> = 5.5 V, V <sub>IL</sub> = 0.4 V		1, 2, 3	All		-400	μA
Short circuit output current	I <sub>OS</sub>	V <sub>CC</sub> = 5.5 V, V <sub>OUT</sub> = 0.0 V <u>1/</u>		1, 2, 3	All	-6	-130	mA
Supply current	I <sub>CC</sub>	V <sub>CC</sub> = 5.5 V, V <sub>IN</sub> = 0.0 V <u>2/</u>		1, 2, 3	All		7	mA
Functional tests		See 4.3.1c		7	All			
Propagation delay time, $\bar{S}$ to Q	t <sub>PHL1</sub>	V <sub>CC</sub> = 5.0 V, R <sub>L</sub> = 2 kΩ ±5% <u>3/</u>	C <sub>L</sub> = 15 pF ±10%	9	All		21	ns
				10, 11	All		29	ns
			C <sub>L</sub> = 50 pF ±10%	9	All		24	ns
			10, 11	All		33	ns	
	t <sub>PLH1</sub>		C <sub>L</sub> = 15 pF ±10%	9	All		22	ns
				10, 11	All		31	ns
C <sub>L</sub> = 50 pF ±10%		9	All		27	ns		
	10, 11	All		38	ns			
Propagation delay time, $\bar{R}$ to Q	t <sub>PHL2</sub>		C <sub>L</sub> = 15 pF ±10%	9	All		27	ns
				10, 11	All		38	ns
			C <sub>L</sub> = 50 pF ±10%	9	All		32	ns
				10, 11	All		45	ns

1/ Not more than one output will be tested at a time, and the duration of the test condition shall not exceed one second.

2/ I<sub>CC</sub> shall be measured with all  $\bar{R}$  inputs grounded, all  $\bar{S}$  inputs at 4.5 V<sub>m</sub>, and all outputs open.

3/ Propagation delay time testing may be performed using either C<sub>L</sub> = 15 pF or C<sub>L</sub> = 50 pF. However, the manufacturer must certify and guarantee that the microcircuits meet the switching test limits specified for a 50 pF load.

**STANDARD  
MICROCIRCUIT DRAWING**  
DLA LAND AND MARITIME  
COLUMBUS, OHIO 43218-3990

SIZE  
**A**

**76018**

REVISION LEVEL  
**J**

SHEET  
**5**

Case outlines	E and F	2
Terminal number	Terminal symbol	
1	$1\bar{R}$	NC
2	$1\bar{S}1$	$1\bar{R}$
3	$1\bar{S}2$	$1\bar{S}1$
4	$1Q$	$1\bar{S}2$
5	$2\bar{R}$	$1Q$
6	$2\bar{S}$	NC
7	$2Q$	$2\bar{R}$
8	GND	$2\bar{S}$
9	$3Q$	$2Q$
10	$3\bar{R}$	GND
11	$3\bar{S}1$	NC
12	$3\bar{S}2$	$3Q$
13	$4Q$	$3\bar{R}$
14	$4\bar{R}$	$3\bar{S}1$
15	$4\bar{S}$	$3\bar{S}2$
16	V <sub>cc</sub>	NC
17	---	$4Q$
18	---	$4\bar{R}$
19	---	$4\bar{S}$
20	---	V <sub>cc</sub>

FIGURE 1. Terminal connections.

INPUTS		OUTPUTs
$\bar{S}$	$\bar{R}$	Q
H	H	Q <sub>0</sub>
L	H	H
H	L	L
L	L	H*

H = high level.

L = low level.

Q<sub>0</sub> = The level of Q before the indicated input conditions were established.

\* = This output level is pseudo stable; that is, it may not persist when the  $\bar{S}$  and  $\bar{R}$  inputs return to their inactive (high) level.

+ = For latches with double  $\bar{S}$  inputs:

H = both  $\bar{S}$  inputs high.

L = one or both  $\bar{S}$  inputs low.

FIGURE 2. Truth table.

<b>STANDARD MICROCIRCUIT DRAWING</b> DLA LAND AND MARITIME COLUMBUS, OHIO 43218-3990	SIZE <b>A</b>		<b>76018</b>
		REVISION LEVEL <b>J</b>	SHEET <b>6</b>

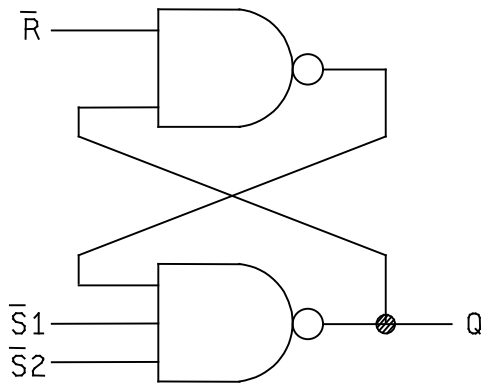

LATCHES 1 AND 3

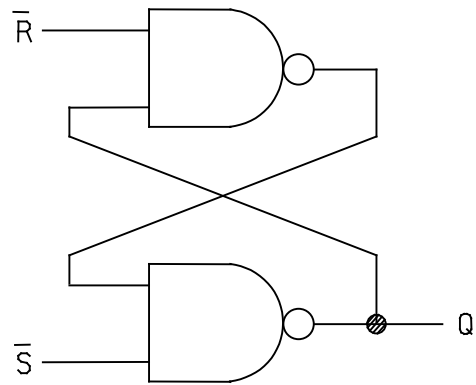

LATCHES 2 AND 4

FIGURE 3. Logic diagram.

**STANDARD  
MICROCIRCUIT DRAWING**

DLA LAND AND MARITIME  
COLUMBUS, OHIO 43218-3990

SIZE  
**A**

**76018**

REVISION LEVEL  
**J**

SHEET  
**7**

4. VERIFICATION

4.1 Sampling and inspection. Sampling and inspection procedures shall be in accordance with MIL-PRF-38535, appendix A.

4.2 Screening. Screening shall be in accordance with method 5004 of MIL-STD-883, and shall be conducted on all devices prior to quality conformance inspection. The following additional criteria shall apply:

a. Burn-in test, method 1015 of MIL-STD-883.

(1) Test condition A, B, C or D. The test circuit shall be maintained by the manufacturer under document revision level control and shall be made available to the preparing or acquiring activity upon request. The test circuit shall specify the inputs, outputs, biases, and power dissipation, as applicable, in accordance with the intent specified in method 1015 of MIL-STD-883.

(2) T<sub>A</sub> = +125°C, minimum.

b. Interim and final electrical test parameters shall be as specified in table II herein, except interim electrical parameter tests prior to burn-in are optional at the discretion of the manufacturer.

TABLE II. Electrical test requirements.

MIL-STD-883 test requirements	Subgroups (in accordance with MIL-STD-883, method 5005, table I)
Interim electrical parameters (method 5004)	- - -
Final electrical test parameters (method 5004)	1*, 2, 3, 9
Group A test requirements (method 5005)	1, 2, 3, 7, 9, 10**, 11**
Groups C and D end-point electrical parameters (method 5005)	1, 2, 3

\* PDA applies to subgroup 1.

\*\* Subgroups 10 and 11, if not tested, shall be guaranteed to the specified limits in table I.

4.3 Quality conformance inspection. Quality conformance inspection shall be in accordance with method 5005 of MIL-STD-883 including groups A, B, C, and D inspections. The following additional criteria shall apply.

4.3.1 Group A inspection.

a. Tests shall be as specified in table II herein.

b. Subgroups 4, 5, 6 and 8 in table I, method 5005 of MIL-STD-883 shall be omitted.

c. Subgroups 7 shall include verification of the truth table.

<b>STANDARD MICROCIRCUIT DRAWING</b> DLA LAND AND MARITIME COLUMBUS, OHIO 43218-3990	SIZE <b>A</b>		<b>76018</b>
		REVISION LEVEL <b>J</b>	SHEET <b>8</b>



4.3.2 Groups C and D inspections.

- a. End-point electrical parameters shall be as specified in table II herein.
- b. Steady-state life test conditions, method 1005 of MIL-STD-883.
  - (1) Test condition A, B, C or D. The test circuit shall be maintained by the manufacturer under document revision level control and shall be made available to the preparing or acquiring activity upon request. The test circuit shall specify the inputs, outputs, biases, and power dissipation, as applicable, in accordance with the intent specified in method 1005 of MIL-STD-883.
  - (2)  $T_A = +125^{\circ}\text{C}$ , minimum.
  - (3) Test duration: 1,000 hours, except as permitted by method 1005 of MIL-STD-883.

5. PACKAGING

5.1 Packaging requirements. The requirements for packaging shall be in accordance with MIL-PRF-38535, appendix A.

6. NOTES

6.1 Intended use. Microcircuits conforming to this drawing are intended for use for Government microcircuit applications (original equipment), design applications, and logistics purposes.

6.2 Replaceability. Microcircuits covered by this drawing will replace the same generic device covered by a contractor-prepared specification or drawing.

6.3 Configuration control of SMD's. All proposed changes to existing SMD's will be coordinated with the users of record for the individual documents. This coordination will be accomplished using DD Form 1692, Engineering Change Proposal.

6.4 Record of users. Military and industrial users shall inform DLA Land and Maritime when a system application requires configuration control and the applicable SMD to that system. DLA Land and Maritime will maintain a record of users and this list will be used for coordination and distribution of changes to the drawings. Users of drawings covering microelectronics devices (FSC 5962) should contact DLA Land and Maritime -VA, telephone (614) 692-8108.

6.5 Comments. Comments on this drawing should be directed to DLA Land and Maritime -VA, Columbus, Ohio 43218-3990, or telephone (614) 692-0540.

6.6 Approved sources of supply. Approved sources of supply are listed in MIL-HDBK-103 and QML-38535. The vendors listed in MIL-HDBK-103 and QML-38535 have agreed to this drawing and a certificate of compliance (see 3.6 herein) has been submitted to and accepted by DLA Land and Maritime -VA.

<b>STANDARD MICROCIRCUIT DRAWING</b> DLA LAND AND MARITIME COLUMBUS, OHIO 43218-3990	SIZE <b>A</b>		<b>76018</b>
		REVISION LEVEL <b>J</b>	SHEET <b>9</b>

STANDARD MICROCIRCUIT DRAWING BULLETIN

DATE: 17-06-16

Approved sources of supply for SMD 76018 are listed below for immediate acquisition information only and shall be added to MIL-HDBK-103 and QML-38535 during the next revision. MIL-HDBK-103 and QML-38535 will be revised to include the addition or deletion of sources. The vendors listed below have agreed to this drawing and a certificate of compliance has been submitted to and accepted by DLA Land and Maritime -VA. This information bulletin is superseded by the next dated revision of MIL-HDBK-103 and QML-38535. DLA Land and Maritime maintains an online database of all current sources of supply at <https://landandmaritimeapps.dla.mil/Programs/Smcr/>.

Standard microcircuit drawing PIN <u>1/</u>	Vendor CAGE number	Vendor similar PIN <u>2/</u>	Reference military specification PIN
7601801EA	01295 <u>3/</u>	SNJ54LS279AJ 54LS279/BEAJC	M38510/31602BEA
7601801FA	01295 <u>3/</u>	SNJ54LS279AW 54LS279/BFAJC	M38510/31602BFA
76018012A	01295 <u>3/</u>	SNJ54LS279AFK 54LS279M/B2AJC	M38510/31602B2A

- 1/ The lead finish shown for each PIN representing a hermetic package is the most readily available from the manufacturer listed for that part. If the desired lead finish is not listed contact the vendor to determine its availability.
- 2/ Caution. Do not use this number for item acquisition. Items acquired to this number may not satisfy the performance requirements of this drawing.
- 3/ Not available from an approved source of supply.

Vendor CAGE  
number

01295

Vendor name  
and address

Texas Instruments, Inc.  
Semiconductor Group  
8505 Forest Ln.  
P.O. Box 660199  
Dallas, TX 75243

The information contained herein is disseminated for convenience only and the Government assumes no liability whatsoever for any inaccuracies in the information bulletin.