

REVISIONS

LTR	DESCRIPTION	DATE (YR-MO-DA)	APPROVED
E	Delete vendor, CAGE 34335, CAGE 07263, CAGE 27014, and CAGE 18324. Add logic diagram. Table I, change LOS(min), from -6 to -15. Table I, change the following from (CL = 50 pF, subgroups 10 and 11): tPLH1 and tPHZ1 from 70 ns to 75 ns. tPHL2 and tPLH2 from 53 ns to 57 ns. tPHL3 and tPLH3 from 46 ns to 50 ns. tPHL4 and tPLH4, from 28 ns to 30 ns. tPZL1 and tPZL2, from 63 ns to 68 ns. tPHZ2 from 45 ns to 48 ns. tPLZ1 and tPLZ2 from 42 ns to 45 ns. tPHZ2 from 84 ns to 90 ns. Editorial changes throughout. Change Code Ident. No. to 67268. Revise to Military Drawing format.	87-10-06	R. P. Evans
F	Changes in accordance with NOR 5962-R139-92. pvn	92-02-21	Monica L. Poelking
G	Changes in accordance with NOR 5962-R166-96. les	96-07-30	Raymond Monnin
H	Update to reflect latest changes in format and requirements. Editorial changes throughout. --les	03-03-05	Raymond Monnin
J	Update to reflect latest changes in format and requirements. Correct paragraph in 3.5. Editorial changes throughout. --les	05-08-02	Raymond Monnin
K	Update drawing to current MIL-PRF-38535 requirements. -jt	17-06-16	Charles Saffle

THE ORIGINAL FIRST PAGE OF THIS DRAWING HAS BEEN REPLACED.

**CURRENT CAGE CODE 67268**



REV																			
SHEET																			
REV																			
SHEET																			
REV STATUS	REV	K	K	K	K	K	K	K	K	K	K	K	K	K					
OF SHEETS	SHEET	1	2	3	4	5	6	7	8	9	10	11							

PMIC N/A	PREPARED BY Monica L. Grosel	<p align="center"><b>DLA LAND AND MARITIME COLUMBUS, OHIO 43218-3990</b>  <a href="http://www.landandmaritime.dla.mil">http://www.landandmaritime.dla.mil</a></p> <p align="center"><b>MICROCIRCUIT, DIGITAL, BIPOLAR, LOW-POWER SCHOTTKY TTL, MULTIPLEXER, MONOLITHIC SILICON</b></p>																	
<p align="center"><b>STANDARD MICROCIRCUIT DRAWING</b></p> <p>THIS DRAWING IS AVAILABLE FOR USE BY ALL DEPARTMENTS AND AGENCIES OF THE DEPARTMENT OF DEFENSE</p>	CHECKED BY D. A. DiCenzo																		
	APPROVED BY Robert P. Evans																		
	DRAWING APPROVAL DATE 76-03-23																		
AMSC N/A	REVISION LEVEL K	SIZE A	CAGE CODE <b>14933</b>	<b>76016</b>															
		SHEET		1 OF 11															

1. SCOPE

1.1 Scope. This drawing describes device requirements for MIL-STD-883 compliant, non-JAN class level B microcircuits in accordance with MIL-PRF-38535, appendix A.

1.2 Part or Identifying Number (PIN). The complete PIN is as shown in the following example:

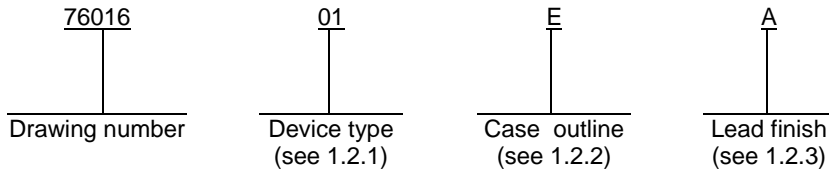

1.2.1 Device types. The device types identify the circuit function as follows:

<u>Device type</u>	<u>Generic number</u>	<u>Circuit function</u>
01	54LS251	Data selector/multiplexer with 3-state outputs

1.2.2 Case outlines. The case outlines are as designated in MIL-STD-1835 and as follows:

<u>Outline letter</u>	<u>Descriptive designator</u>	<u>Terminals</u>	<u>Package style</u>
E	GDIP1-T16 or CDIP2-T16	16	dual-in-line
F	GDFP2-F16 or CDFP3-F16	16	flat

1.2.3 Lead finish. The lead finish is as specified in MIL-PRF-38535, appendix A.

1.3 Absolute maximum ratings.

Supply voltage .....	-0.5 V dc to +7.0 V dc
Input voltage range .....	-1.5 V dc at -18 mA to +5.5 V dc
Storage temperature range .....	-65°C to +150°C
Maximum power dissipation (P <sub>D</sub> ) 1/ .....	66 mW
Lead temperature (soldering, 10 seconds) .....	+300°C
Thermal resistance, junction-to-case (θ <sub>JC</sub> ): .....	See MIL-STD-1835
Junction temperature (T <sub>J</sub> ) .....	+175°C

1.4 Recommended operating conditions.

Supply voltage range (V <sub>CC</sub> ) .....	4.5 V dc minimum to 5.5 V dc maximum
Minimum high level input voltage (V <sub>IH</sub> ) .....	2.0 V dc
Maximum low level input voltage (V <sub>IL</sub> ) .....	0.7 V dc
Case operating temperature range (T <sub>C</sub> ) .....	-55°C to +125°C

<b>STANDARD MICROCIRCUIT DRAWING</b> DLA LAND AND MARITIME COLUMBUS, OHIO 43218-3990	SIZE <b>A</b>		<b>76016</b>
		REVISION LEVEL K	SHEET <b>2</b>

## 2. APPLICABLE DOCUMENTS

2.1 Government specification, standards, and handbooks. The following specification, standards, and handbooks form a part of this drawing to the extent specified herein. Unless otherwise specified, the issues of these documents are those cited in the solicitation or contract.

### DEPARTMENT OF DEFENSE SPECIFICATION

MIL-PRF-38535 - Integrated Circuits, Manufacturing, General Specification for.

### DEPARTMENT OF DEFENSE STANDARDS

MIL-STD-883 - Test Method Standard Microcircuits.  
MIL-STD-1835 - Interface Standard Electronic Component Case Outlines.

### DEPARTMENT OF DEFENSE HANDBOOKS

MIL-HDBK-103 - List of Standard Microcircuit Drawings.  
MIL-HDBK-780 - Standard Microcircuit Drawings.

(Copies of these documents are available online at <http://quicksearch.dla.mil/> or from the Standardization Document Order Desk, 700 Robbins Avenue, Building 4D, Philadelphia, PA 19111-5094.)

2.2 Order of precedence. In the event of a conflict between the text of this drawing and the references cited herein, the text of this drawing takes precedence. Nothing in this document, however, supersedes applicable laws and regulations unless a specific exemption has been obtained.

## 3. REQUIREMENTS

3.1 Item requirements. The individual item requirements shall be in accordance with MIL-PRF-38535, appendix A for non-JAN class level B devices and as specified herein. Product built to this drawing that is produced by a Qualified Manufacturer Listing (QML) certified and qualified manufacturer or a manufacturer who has been granted transitional certification to MIL-PRF-38535 may be processed as QML product in accordance with the manufacturers approved program plan and qualifying activity approval in accordance with MIL-PRF-38535. This QML flow as documented in the Quality Management (QM) plan may make modifications to the requirements herein. These modifications shall not affect form, fit, or function of the device. These modifications shall not affect the PIN as described herein. A "Q" or "QML" certification mark in accordance with MIL-PRF-38535 is required to identify when the QML flow option is used.

3.2 Design, construction, and physical dimensions. The design, construction, and physical dimensions shall be as specified in MIL-PRF-38535, appendix A and herein.

3.2.1 Case outlines. The case outlines shall be in accordance with 1.2.2 herein.

3.2.2 Terminal connections. The terminal connections shall be as specified on figure 1.

3.2.3 Truth table. The truth table shall be as specified on figure 2.

3.2.4 Logic diagram. The logic diagram shall be as specified on figure 3.

3.3 Electrical performance characteristics. Unless otherwise specified herein, the electrical performance characteristics are as specified in table I and shall apply over the full case operating temperature range.

**STANDARD  
MICROCIRCUIT DRAWING**  
DLA LAND AND MARITIME  
COLUMBUS, OHIO 43218-3990

SIZE  
**A**

**76016**

REVISION LEVEL  
K

SHEET  
**3**

3.4 Electrical test requirements. The electrical test requirements shall be the subgroups specified in table II. The electrical tests for each subgroup are described in table I.

3.5 Marking. Marking shall be in accordance with MIL-PRF-38535, appendix A. The part shall be marked with the PIN listed in 1.2 herein. In addition, the manufacturer's PIN may also be marked.

3.5.1 Certification/compliance mark. A compliance indicator "C" shall be marked on all non-JAN devices built in compliance to MIL-PRF-38535, appendix A. The compliance indicator "C" shall be replaced with a "Q" or "QML" certification mark in accordance with MIL-PRF-38535 to identify when the QML flow option is used.

3.6 Certificate of compliance. A certificate of compliance shall be required from a manufacturer in order to be listed as an approved source of supply in MIL-HDBK-103 (see 6.6 herein). The certificate of compliance submitted to DLA Land and Maritime -VA prior to listing as an approved source of supply shall affirm that the manufacturer's product meets the requirements of MIL-PRF-38535, appendix A and the requirements herein.

3.7 Certificate of conformance. A certificate of conformance as required in MIL-PRF-38535, appendix A shall be provided with each lot of microcircuits delivered to this drawing.

3.8 Notification of change. Notification of change to DLA Land and Maritime -VA shall be required for any change that affects this drawing.

3.9 Verification and review. DLA Land and Maritime, DLA Land and Maritime's agent, and the acquiring activity retain the option to review the manufacturer's facility and applicable required documentation. Offshore documentation shall be made available onshore at the option of the reviewer.

**STANDARD  
MICROCIRCUIT DRAWING**  
DLA LAND AND MARITIME  
COLUMBUS, OHIO 43218-3990

SIZE  
**A**

**76016**

REVISION LEVEL  
K

SHEET  
**4**

TABLE I. Electrical performance characteristics.

Test	Symbol	Conditions -55°C ≤ T <sub>c</sub> ≤ +125°C unless otherwise specified		Group A subgroups	Device type	Limits		Unit
						Min	Max	
High level output voltage	V <sub>OH</sub>	V <sub>CC</sub> = 4.5 V, I <sub>OH</sub> = -1.0 mA V <sub>IL</sub> = 0.7 V, V <sub>IH</sub> = 2.0 V		1, 2, 3	All	2.4		V
Low level output voltage	V <sub>OL</sub>	V <sub>CC</sub> = 4.5 V, I <sub>OL</sub> = 4.0 mA V <sub>IL</sub> = 0.7 V, V <sub>IH</sub> = 2.0 V		1, 2, 3	All		0.4	V
Input clamp voltage	V <sub>IC</sub>	V <sub>CC</sub> = 4.5 V, I <sub>IN</sub> = -18 mA,		1	All		-1.5	V
High level input current	I <sub>IH1</sub>	V <sub>CC</sub> = 5.5 V, V <sub>IH</sub> = 2.7 V		1, 2, 3	All		20	μA
	I <sub>IH2</sub>	V <sub>CC</sub> = 5.5 V, V <sub>IH</sub> = 5.5 V		1, 2, 3	All		100	μA
Off-state output current	I <sub>O (off)</sub>	V <sub>CC</sub> = 5.5 V, V <sub>OUT</sub> = 2.4 V		1, 2, 3	All		20	μA
		V <sub>IH</sub> = 2.0 V, V <sub>OUT</sub> = 0.4 V		1, 2, 3	All		-20	μA
Low level input current data inputs	I <sub>IL1</sub>	V <sub>CC</sub> = 5.5 V,		1, 2, 3	All		-720	μA
Low level input current enable inputs	I <sub>IL2</sub>	V <sub>IL</sub> = 0.4 V		1, 2, 3	All		-200	μA
Low level input current select inputs	I <sub>IL3</sub>			1, 2, 3	All		-400	μA
Short circuit output current	I <sub>OS</sub>	V <sub>CC</sub> = 5.5 V, V <sub>OUT</sub> = 0.0 V 1/		1, 2, 3	All	-15	-130	mA
Supply current	I <sub>CC</sub>	V <sub>CC</sub> = 5.5 V, enable grounded		1, 2, 3	All		10	mA
		V <sub>CC</sub> = 5.5 V, strobe at 4.5 V		1, 2, 3	All		12	mA
Functional tests		See 4.3.1c		7	All			
Propagation delay time, A, B, or C (4 levels) to Y	t <sub>PHL1</sub>	V <sub>CC</sub> = 5.0 V, R <sub>L</sub> = 2 kΩ ±5% 2/	C <sub>L</sub> = 15 pF ±10%	9	All		45	ns
				10, 11	All		63	ns
	C <sub>L</sub> = 50 pF ±10%		9	All		50	ns	
			10, 11	All		75	ns	
	t <sub>PLH1</sub>		C <sub>L</sub> = 15 pF ±10%	9	All		45	ns
				10, 11	All		63	ns
	C <sub>L</sub> = 50 pF ±10%	9	All		50	ns		
		10, 11	All		75	ns		

See footnotes at end of table.

**STANDARD  
MICROCIRCUIT DRAWING**  
DLA LAND AND MARITIME  
COLUMBUS, OHIO 43218-3990

SIZE  
**A**

**76016**

REVISION LEVEL  
K

SHEET

**5**

TABLE I. Electrical performance characteristics - Continued.

Test	Symbol	Conditions -55°C ≤ T <sub>c</sub> ≤ +125°C unless otherwise specified		Group A subgroups	Device type	Limits		Unit
						Min	Max	
Propagation delay time, A, B, or C (3 levels) to W	t <sub>PHL2</sub>	V <sub>CC</sub> = 5.0 V, R <sub>L</sub> = 2 kΩ ±5%  2/	C <sub>L</sub> = 15 pF ±10%	9	All		33	ns
				10, 11	All		46	ns
	C <sub>L</sub> = 50 pF ±10%		9	All		38	ns	
			10, 11	All		57	ns	
	t <sub>PLH2</sub>		C <sub>L</sub> = 15 pF ±10%	9	All		33	ns
				10, 11	All		46	ns
	C <sub>L</sub> = 50 pF ±10%	9	All		38	ns		
		10, 11	All		57	ns		
Propagation delay time, any D to Y	t <sub>PHL3</sub>	C <sub>L</sub> = 15 pF ±10%	9	All		28	ns	
			10, 11	All		39	ns	
	C <sub>L</sub> = 50 pF ±10%	9	All		33	ns		
		10, 11	All		50	ns		
	t <sub>PLH3</sub>	C <sub>L</sub> = 15 pF ±10%	9	All		28	ns	
			10, 11	All		39	ns	
	C <sub>L</sub> = 50 pF ±10%	9	All		33	ns		
		10, 11	All		50	ns		
Propagation delay time, any D to W	t <sub>PHL4</sub>	C <sub>L</sub> = 15 pF ±10%	9	All		15	ns	
			10, 11	All		21	ns	
	C <sub>L</sub> = 50 pF ±10%	9	All		20	ns		
		10, 11	All		30	ns		
	t <sub>PLH4</sub>	C <sub>L</sub> = 15 pF ±10%	9	All		15	ns	
			10, 11	All		21	ns	
	C <sub>L</sub> = 50 pF ±10%	9	All		20	ns		
		10, 11	All		30	ns		
Output enable time, strobe to Y	t <sub>PZH1</sub>	C <sub>L</sub> = 15 pF ±10%	9	All		45	ns	
			10, 11	All		63	ns	
	C <sub>L</sub> = 50 pF ±10%	9	All		50	ns		
		10, 11	All		75	ns		
	t <sub>PZL1</sub>	C <sub>L</sub> = 15 pF ±10%	9	All		40	ns	
			10, 11	All		56	ns	
	C <sub>L</sub> = 50 pF ±10%	9	All		45	ns		
		10, 11	All		68	ns		

See footnotes at end of table.

**STANDARD  
MICROCIRCUIT DRAWING**  
DLA LAND AND MARITIME  
COLUMBUS, OHIO 43218-3990

SIZE  
**A**

REVISION LEVEL  
**K**

**76016**

SHEET  
**6**

TABLE I. Electrical performance characteristics - Continued.

Test	Symbol	Conditions -55°C ≤ T <sub>c</sub> ≤ +125°C unless otherwise specified		Group A subgroups	Device type	Limits		Unit
						Min	Max	
Output enable time, strobe to W	t <sub>PZH2</sub>	V <sub>CC</sub> = 5.0 V, R <sub>L</sub> = 2 kΩ ±5%	C <sub>L</sub> = 15 pF ±10%	9	All		27	ns
				10, 11	All		38	ns
	C <sub>L</sub> = 50 pF ±10%		9	All		32	ns	
			10, 11	All		48	ns	
	t <sub>PZL2</sub>		C <sub>L</sub> = 15 pF ±10%	9	All		40	ns
				10, 11	All		56	ns
C <sub>L</sub> = 50 pF ±10%	9	All		45	ns			
	10, 11	All		68	ns			
Output disable time, from strobe to Y	t <sub>PHZ1</sub>	V <sub>CC</sub> = 5.0 V, R <sub>L</sub> = 2 kΩ ±5%	C <sub>L</sub> = 15 pF ±10%	9	All		45	ns
				10, 11	All		63	ns
	C <sub>L</sub> = 50 pF ±10%		9	All		50	ns	
			10, 11	All		75	ns	
	t <sub>PLZ1</sub>		C <sub>L</sub> = 15 pF ±10%	9	All		25	ns
				10, 11	All		35	ns
C <sub>L</sub> = 50 pF ±10%	9	All		35	ns			
	10, 11	All		45	ns			
Output disable time, from strobe to W	t <sub>PHZ2</sub>	V <sub>CC</sub> = 5.0 V, R <sub>L</sub> = 2 kΩ ±5%	C <sub>L</sub> = 15 pF ±10%	9	All		55	ns
				10, 11	All		77	ns
	C <sub>L</sub> = 50 pF ±10%		9	All		60	ns	
			10, 11	All		90	ns	
	t <sub>PLZ2</sub>		C <sub>L</sub> = 15 pF ±10%	9	All		25	ns
				10, 11	All		35	ns
C <sub>L</sub> = 50 pF ±10%	9	All		35	ns			
	10, 11	All		45	ns			

- 1/ Not more than one output should be shorted at a time, and the duration of the short-circuit condition should not exceed one second.
- 2/ Propagation delay time testing may be performed using either C<sub>L</sub> = 15 pF or C<sub>L</sub> = 50 pF. However, the manufacturer must certify and guarantee that the microcircuits meet the switching test limits specified for a 50 pF load.

**STANDARD  
MICROCIRCUIT DRAWING**  
DLA LAND AND MARITIME  
COLUMBUS, OHIO 43218-3990

SIZE  
**A**

REVISION LEVEL  
K

**76016**

SHEET  
**7**

Device types	01
Case outlines	E, F
Terminal number	Terminal symbols
1	D3
2	D2
3	D1
4	D0
5	Y
6	W
7	$\bar{G}$
8	GND
9	C
10	B
11	A
12	D7
13	D6
14	D5
15	D4
16	V <sub>cc</sub>

FIGURE 1. Terminal connections.

INPUTS			ENABLE	OUTPUTS	
SELECT				$\bar{G}$	Y
C	B	A			
X	X	X	H	Z	$\bar{Z}$
L	L	L	L	D0	$\bar{D0}$
L	L	H	L	D1	$\bar{D1}$
L	H	L	L	D2	$\bar{D2}$
L	H	H	L	D3	$\bar{D3}$
H	L	L	L	D4	$\bar{D4}$
H	L	H	L	D5	$\bar{D5}$
H	H	L	L	D6	$\bar{D6}$
H	H	H	L	D7	$\bar{D7}$

H = High logic level.  
L = Low logic level.  
X = Irrelevant  
Z = High impedance (off)  
D0, D1...D7 = The level of the respective D input.

FIGURE 2. Truth table.

<b>STANDARD MICROCIRCUIT DRAWING</b> DLA LAND AND MARITIME COLUMBUS, OHIO 43218-3990	SIZE <b>A</b>		<b>76016</b>
		REVISION LEVEL K	SHEET <b>8</b>



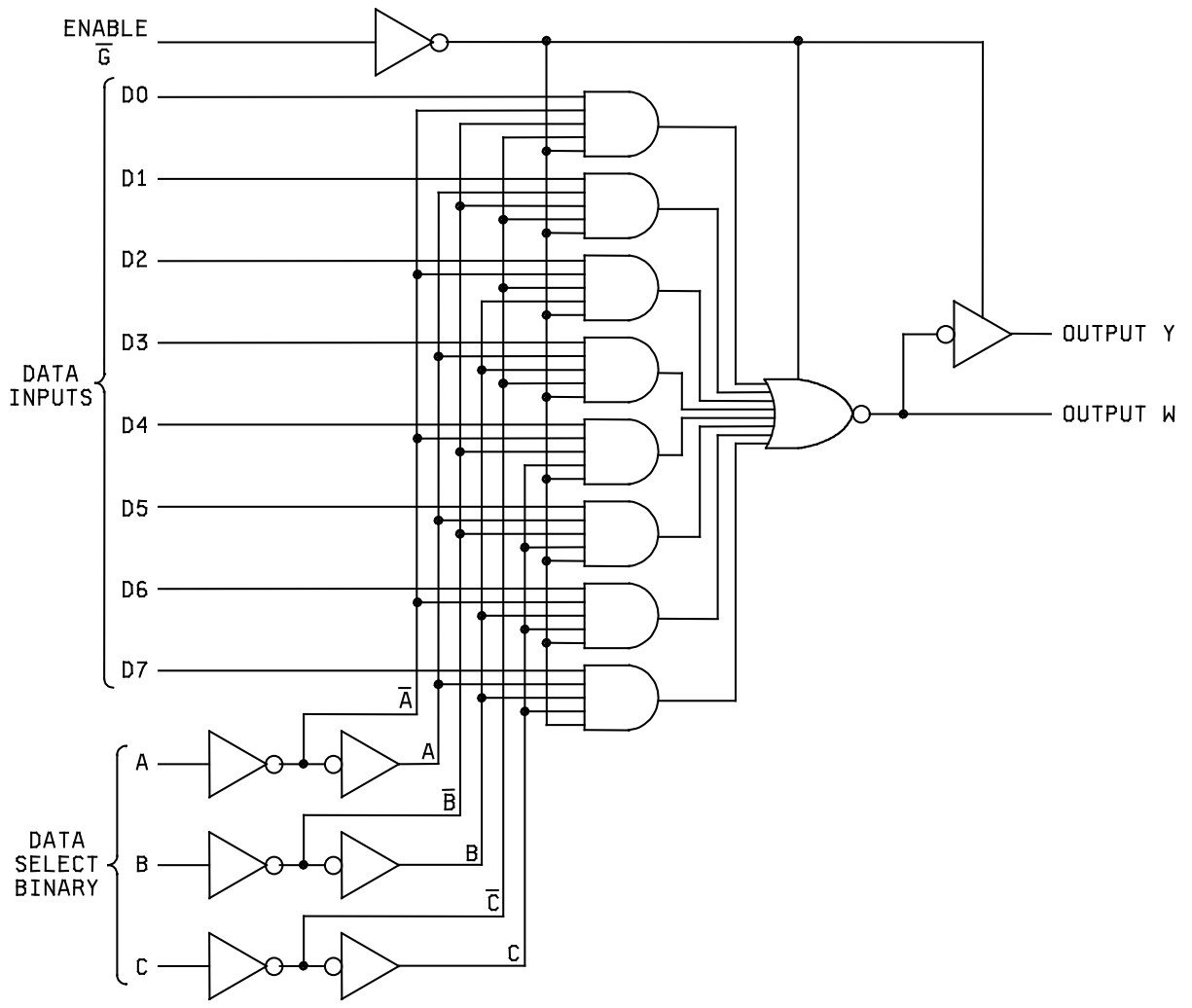

FIGURE 3. Logic diagram.

**STANDARD  
MICROCIRCUIT DRAWING**  
DLA LAND AND MARITIME  
COLUMBUS, OHIO 43218-3990

SIZE  
**A**

**76016**

REVISION LEVEL  
K

SHEET  
**9**

4. VERIFICATION

4.1 Sampling and inspection. Sampling and inspection procedures shall be in accordance with MIL-PRF-38535, appendix A.

4.2 Screening. Screening shall be in accordance with method 5004 of MIL-STD-883, and shall be conducted on all devices prior to quality conformance inspection. The following additional criteria shall apply:

a. Burn-in test, method 1015 of MIL-STD-883.

(1) Test condition A, B, C or D. The test circuit shall be maintained by the manufacturer under document revision level control and shall be made available to the preparing or acquiring activity upon request. The test circuit shall specify the inputs, outputs, biases, and power dissipation, as applicable, in accordance with the intent specified in method 1015 of MIL-STD-883.

(2) T<sub>A</sub> = +125°C, minimum.

b. Interim and final electrical test parameters shall be as specified in table II herein, except interim electrical parameter tests prior to burn-in are optional at the discretion of the manufacturer.

TABLE II. Electrical test requirements.

MIL-STD-883 test requirements	Subgroups (in accordance with MIL-STD-883, method 5005, table I)
Interim electrical parameters (method 5004)	---
Final electrical test parameters (method 5004)	1*, 2, 3, 9
Group A test requirements (method 5005)	1, 2, 3, 7, 9, 10**, 11**
Groups C and D end-point electrical parameters (method 5005)	1, 2, 3

\* PDA applies to subgroup 1.

\*\* Subgroups 10 and 11, if not tested, shall be guaranteed to the specified limits in table I.

4.3 Quality conformance inspection. Quality conformance inspection shall be in accordance with method 5005 of MIL-STD-883 including groups A, B, C, and D inspections. The following additional criteria shall apply.

4.3.1 Group A inspection.

a. Tests shall be as specified in table II herein.

b. Subgroups 4, 5, 6 and 8 in table I, method 5005 of MIL-STD-883 shall be omitted.

c. Subgroups 7 shall include verification of the truth table.

<b>STANDARD MICROCIRCUIT DRAWING</b> DLA LAND AND MARITIME COLUMBUS, OHIO 43218-3990	SIZE <b>A</b>		<b>76016</b>
		REVISION LEVEL K	SHEET <b>10</b>

4.3.2 Groups C and D inspections.

- a. End-point electrical parameters shall be as specified in table II herein.
- b. Steady-state life test conditions, method 1005 of MIL-STD-883.
  - (1) Test condition A, B, C or D. The test circuit shall be maintained by the manufacturer under document revision level control and shall be made available to the preparing or acquiring activity upon request. The test circuit shall specify the inputs, outputs, biases, and power dissipation, as applicable, in accordance with the intent specified in method 1005 of MIL-STD-883.
  - (2)  $T_A = +125^{\circ}\text{C}$ , minimum.
  - (3) Test duration: 1,000 hours, except as permitted by method 1005 of MIL-STD-883.

5. PACKAGING

5.1 Packaging requirements. The requirements for packaging shall be in accordance with MIL-PRF-38535, appendix A.

6. NOTES

6.1 Intended use. Microcircuits conforming to this drawing are intended for use for Government microcircuit applications (original equipment), design applications, and logistics purposes.

6.2 Replaceability. Microcircuits covered by this drawing will replace the same generic device covered by a contractor-prepared specification or drawing.

6.3 Configuration control of SMD's. All proposed changes to existing SMD's will be coordinated with the users of record for the individual documents. This coordination will be accomplished using DD Form 1692, Engineering Change Proposal.

6.4 Record of users. Military and industrial users shall inform DLA Land and Maritime when a system application requires configuration control and the applicable SMD to that system. DLA Land and Maritime will maintain a record of users and this list will be used for coordination and distribution of changes to the drawings. Users of drawings covering microelectronics devices (FSC 5962) should contact DLA Land and Maritime -VA, telephone (614) 692-8108.

6.5 Comments. Comments on this drawing should be directed to DLA Land and Maritime -VA, Columbus, Ohio 43218-3990, or telephone (614) 692-0540.

6.6 Approved sources of supply. Approved sources of supply are listed in MIL-HDBK-103 and QML-38535. The vendors listed in MIL-HDBK-103 and QML-38535 have agreed to this drawing and a certificate of compliance (see 3.6 herein) has been submitted to and accepted by DLA Land and Maritime -VA.

<b>STANDARD MICROCIRCUIT DRAWING</b> DLA LAND AND MARITIME COLUMBUS, OHIO 43218-3990	SIZE <b>A</b>		<b>76016</b>
		REVISION LEVEL K	SHEET <b>11</b>

STANDARD MICROCIRCUIT DRAWING BULLETIN

DATE: 17-06-16

Approved sources of supply for SMD 76016 are listed below for immediate acquisition information only and shall be added to MIL-HDBK-103 and QML-38535 during the next revision. MIL-HDBK-103 and QML-38535 will be revised to include the addition or deletion of sources. The vendors listed below have agreed to this drawing and a certificate of compliance has been submitted to and accepted by DLA Land and Maritime -VA. This information bulletin is superseded by the next dated revision of MIL-HDBK-103 and QML-38535. DLA Land and Maritime maintains an online database of all current sources of supply at <https://landandmaritimeapps.dla.mil/Programs/Smcr/>.

Standard microcircuit drawing PIN <u>1/</u>	Vendor CAGE number	Vendor similar PIN <u>2/</u>	Reference military specification PIN
7601601EA	58625 01295 <u>3/</u>	SL54LS251/BEA SNJ54LS251J 54LS251/BEAJC	M38510/30905BEA
7601601FA	58625 01295 <u>3/</u> <u>3/</u>	SL54LS251/BFA SNJ54LS251W GEM08701BFA 54LS251/BFAJC	M38510/30905BFA
7601601FC	<u>3/</u>	GEM08701BFC	M38510/30905BFC

- 1/ The lead finish shown for each PIN representing a hermetic package is the most readily available from the manufacturer listed for that part. If the desired lead finish is not listed contact the vendor to determine its availability.
- 2/ Caution. Do not use this number for item acquisition. Items acquired to this number may not satisfy the performance requirements of this drawing.
- 3/ Not available from an approved source of supply.

Vendor CAGE  
number

Vendor name  
and address

01295

Texas Instruments, Inc.  
Semiconductor Group  
8505 Forest Ln.  
PO Box 660199  
Dallas, TX 75243

58625

Lansdale Semiconductor Inc.  
5245 S. 39th St.  
Phoenix, AZ 85040-9008

The information contained herein is disseminated for convenience only and the Government assumes no liability whatsoever for any inaccuracies in the information bulletin.