

**REVISIONS**

LTR	DESCRIPTION	DATE (YR-MO-DA)	APPROVED
A	Add a SCLK frequency test under Table I. - ro	09-07-22	C. SAFFLE
B	Under paragraph 1.5, footnote 8/, delete the effective dose rate of "0.16 rad(Si)/s" and substitute "0.027 rad(Si)/s". Add supply current limits to Table IIB. - ro	10-05-06	C. SAFFLE
C	Under Table IA, make correction to full scale output test by moving all limits from the maximum column to the minimum limit column. Make change to footnote 1/ under Table IIB. - ro	10-06-23	C. SAFFLE
D	Add device type 02. - ro	12-05-08	C. SAFFLE
E	Add paragraph 3.1.1 and Appendix A for microcircuit die. Delete references to device class M requirements. - ro	15-10-23	C. SAFFLE
F	Update paragraphs to current MIL-PRF-38535 requirements. - drw	21-05-14	James R. Eschmeyer



REV																				
SHEET																				
REV	F	F	F	F	F	F	F	F												
SHEET	15	16	17	18	19	20	21	22												
REV STATUS OF SHEETS	REV			F	F	F	F	F	F	F	F	F	F	F	F	F	F	F	F	
	SHEET			1	2	3	4	5	6	7	8	9	10	11	12	13	14			

PMIC N/A	PREPARED BY Rick Officer	<p align="center"><b>DLA LAND AND MARITIME COLUMBUS, OHIO 43218-3990</b>  <a href="https://www.dla.mil/LandandMaritime">https://www.dla.mil/LandandMaritime</a></p>																	
<p align="center"><b>STANDARD MICROCIRCUIT DRAWING</b></p> <p>THIS DRAWING IS AVAILABLE FOR USE BY ALL DEPARTMENTS AND AGENCIES OF THE DEPARTMENT OF DEFENSE</p> <p align="center">AMSC N/A</p>	CHECKED BY Rajesh Pithadia																		
	APPROVED BY Robert M. Herber	<p align="center">MICROCIRCUIT, DIGITAL-LINEAR, CMOS, 12 BIT, DIGITAL-TO-ANALOG CONVERTER, MONOLITHIC SILICON</p>																	
	DRAWING APPROVAL DATE 09-02-12																		
	REVISION LEVEL F	SIZE A	CAGE CODE <b>67268</b>	<b>5962-07226</b>															
		SHEET		1 OF 22															

1. SCOPE

1.1 Scope. This drawing documents two product assurance class levels consisting of high reliability (device class Q) and space application (device class V). A choice of case outlines and lead finishes are available and are reflected in the Part or Identifying Number (PIN). When available, a choice of Radiation Hardness Assurance (RHA) levels is reflected in the PIN.

1.2 PIN. The PIN is as shown in the following example:

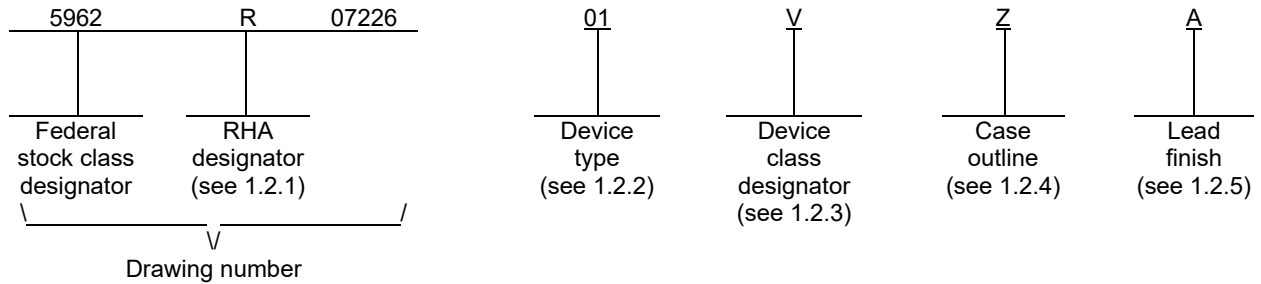

1.2.1 RHA designator. Device classes Q and V RHA marked devices meet the MIL-PRF-38535 specified RHA levels and are marked with the appropriate RHA designator. A dash (-) indicates a non-RHA device.

1.2.2 Device types. The device types identify the circuit function as follows:

<u>Device type</u>	<u>Generic number</u>	<u>Circuit function</u>
01	DAC121S101	12 bit digital-to-analog converter
02	DAC121S101	12 bit digital-to-analog converter

1.2.3 Device class designator. The device class designator is a single letter identifying the product assurance level as follows:

<u>Device class</u>	<u>Device requirements documentation</u>
Q or V	Certification and qualification to MIL-PRF-38535

1.2.4 Case outline. The case outline is as designated in MIL-STD-1835 as follows:

<u>Outline letter</u>	<u>Descriptive designator</u>	<u>Terminals</u>	<u>Package style</u>
Z	GDFP1-G10	10	Flat pack with gullwing leads

1.2.5 Lead finish. The lead finish is as specified in MIL-PRF-38535 for device classes Q and V.

<b>STANDARD MICROCIRCUIT DRAWING</b> DLA LAND AND MARITIME COLUMBUS, OHIO 43218-3990	SIZE <b>A</b>		<b>5962-07226</b>
		REVISION LEVEL <b>F</b>	SHEET <b>2</b>

1.3 Absolute maximum ratings. 1/, 2/

Supply voltage (VA) .....	+6.5 V
Voltage on any input pin .....	-0.3 V to ( VA + 0.3 V )
Input current at any pin .....	10 mA <u>3/</u>
Maximum output current .....	10 mA <u>4/</u>
VOUT pin in powerdown (PD) mode .....	1.0 mA
Package input current .....	20 mA <u>3/</u>
Power dissipation (PD) at TA = +25°C .....	See footnote <u>5/</u>
Maximum junction temperature (TJ) .....	+175°C
Lead temperature (soldering, 10 seconds) .....	+260°C
Storage temperature range .....	-65°C to +150°C
Electrostatic discharge (ESD) tolerance .....	4,000 V <u>6/</u>
Thermal resistance, junction-to-case (θJC) .....	25.7°C/W
Thermal resistance, junction-to-ambient (θJA) .....	214°C/W (still air)

- 1/ Stresses above the absolute maximum rating may cause permanent damage to the device. Extended operation at the maximum levels may degrade performance and affect reliability.
- 2/ Unless otherwise specified, all voltages are measured with respect to GND = 0 V.
- 3/ When the input voltage at any pin exceeds the power supplies ( less than GND or greater than VA ), the current at that pin should be limited to 10 mA. The 20 mA maximum package input current rating limits the number of pins that can safely exceed the power supplies with an input current of 10 mA to two.
- 4/ Maximum output current may not exceed 10 mA. At VDD = 5.5 V, the minimum external resistive load can be no less than 550Ω, (360Ω at VDD = 3.6 V).
- 5/ The absolute maximum junction temperature ( TJmax ) for this device is 175°C. The maximum power dissipation is dictated by TJMAX, the junction to ambient thermal resistance ( θJA ), and the ambient temperature( TA ) and can be calculated using the formula  $PD_{max} = (TJ_{max} - TA) / \theta_{JA}$ . The values for maximum power dissipation will be reached only when the device is operated in a severe fault condition (for example, when input or output pins are driven beyond the power supply voltages, or the power supply polarity is reversed). These conditions should be avoided.
- 6/ Human body model (HBM) is 100 pF capacitor discharged through a 1.5 kΩ resistor.

<b>STANDARD MICROCIRCUIT DRAWING</b> DLA LAND AND MARITIME COLUMBUS, OHIO 43218-3990	SIZE <b>A</b>		<b>5962-07226</b>
		REVISION LEVEL <b>F</b>	SHEET <b>3</b>

1.4 Recommended operating conditions. 1/, 2/

Supply voltage range (VA) .....	+2.7 V to +5.5 V
Any input voltage .....	-0.1 V to ( VA + 0.1 V ) <u>7/</u>
Output load capacitance .....	0 to 1500 pF
Select clock (SCLK) frequency .....	Up to 20 MHz
Ambient operating temperature (TA) .....	-55°C to +125°C

1.5 Radiation features.

Maximum total dose available (dose rate = 50 – 300 rads(Si)/s):	
Device type 01 .....	100 krads(Si) <u>8/</u>
Maximum total dose available (dose rate = 10 mrads(Si)/s):	
Device type 02 .....	100 krads(Si) <u>9/</u>
No single event latch-up (SEL) occurs at effective LET (see 4.4.4.2) .....	$\leq 120 \text{ MeV}/(\text{mg}/\text{cm}^2)$ <u>10/</u>

7/ The analog inputs are protected as shown below. Input voltage magnitudes up to VA + 300 mV or to 300 mV below GND will not damage this device. However, errors in the conversion result can occur if any input goes above VA or below GND by more than 100 mV. For example, if VA is 2.7 VDC, ensure that  $-100 \text{ mV} \leq \text{input voltages} \leq 2.8 \text{ VDC}$  to ensure accurate conversions.

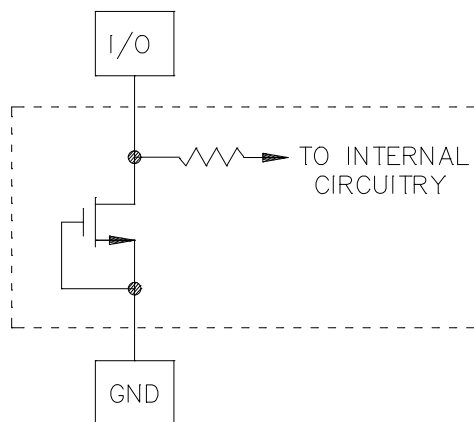

- 8/ Device type 01 is irradiated at dose rate = 50 - 300 rads(Si)/s in accordance with MIL-STD-883, method 1019, condition A, and is guaranteed to a maximum total dose specified. The effective dose rate after extended room temperature anneal = 0.027 rad(Si)/s per MIL-STD-883, method 1019, condition A, section 3.11.2. The total dose specification for this device only applies to the specified effective dose rate, or lower, environment.
- 9/ For device type 02, radiation end point limits for the noted parameters are guaranteed only for the conditions as specified in MIL-STD-883, method 1019, condition D.
- 10/ Limits are based on characterization, but not production tested unless specified on the purchase order or contract. See table IB.

<b>STANDARD MICROCIRCUIT DRAWING</b> DLA LAND AND MARITIME COLUMBUS, OHIO 43218-3990	SIZE <b>A</b>		<b>5962-07226</b>
		REVISION LEVEL <b>F</b>	SHEET <b>4</b>

2. APPLICABLE DOCUMENTS

2.1 Government specification, standards, and handbooks. The following specification, standards, and handbooks form a part of this drawing to the extent specified herein. Unless otherwise specified, the issues of these documents are those cited in the solicitation or contract.

DEPARTMENT OF DEFENSE SPECIFICATION

MIL-PRF-38535 - Integrated Circuits, Manufacturing, General Specification for.

DEPARTMENT OF DEFENSE STANDARDS

MIL-STD-883 - Test Method Standard Microcircuits.  
MIL-STD-1835 - Interface Standard Electronic Component Case Outlines.

DEPARTMENT OF DEFENSE HANDBOOKS

MIL-HDBK-103 - List of Standard Microcircuit Drawings.  
MIL-HDBK-780 - Standard Microcircuit Drawings.

(Copies of these documents are available online at <https://quicksearch.dla.mil>.)

2.2 Non-Government publications. The following document(s) form a part of this document to the extent specified herein. Unless otherwise specified, the issues of these documents are those cited in the solicitation or contract.

ASTM INTERNATIONAL (ASTM)

ASTM F1192 - Standard Guide for the Measurement of Single Event Phenomena (SEP) Induced by Heavy Ion Irradiation of semiconductor Devices.

(Copies of these documents are available online at <https://www.astm.org>).

2.3 Order of precedence. In the event of a conflict between the text of this drawing and the references cited herein, the text of this drawing takes precedence. Nothing in this document, however, supersedes applicable laws and regulations unless a specific exemption has been obtained.

<b>STANDARD MICROCIRCUIT DRAWING</b> DLA LAND AND MARITIME COLUMBUS, OHIO 43218-3990	SIZE <b>A</b>		<b>5962-07226</b>
		REVISION LEVEL F	SHEET 5

### 3. REQUIREMENTS

3.1 Item requirements. The individual item requirements for device classes Q and V shall be in accordance with MIL-PRF-38535 as specified herein, or as modified in the device manufacturer's Quality Management (QM) plan. The modification in the QM plan shall not affect the form, fit, or function as described herein.

3.1.1 Microcircuit die. For the requirements of microcircuit die, see appendix A to this document.

3.2 Design, construction, and physical dimensions. The design, construction, and physical dimensions shall be as specified in MIL-PRF-38535 and herein for device classes Q and V.

3.2.1 Case outline. The case outline shall be in accordance with 1.2.4 herein.

3.2.2 Terminal connections. The terminal connections shall be as specified on figure 1.

3.2.3 Input / output transfer characteristics. The input / output transfer characteristics diagram shall as specified on figure 2.

3.2.4 Timing waveforms. The timing waveforms shall be as specified on figure 3.

3.2.5 Radiation exposure circuit. The radiation exposure circuit shall be maintained by the manufacturer under document revision level control and shall be made available to the preparing and acquiring activity upon request.

3.3 Electrical performance characteristics and postirradiation parameter limits. Unless otherwise specified herein, the electrical performance characteristics and postirradiation parameter limits are as specified in table IA and shall apply over the full ambient operating temperature range.

3.4 Electrical test requirements. The electrical test requirements shall be the subgroups specified in table IIA. The electrical tests for each subgroup are defined in table IA.

3.5 Marking. The part shall be marked with the PIN listed in 1.2 herein. In addition, the manufacturer's PIN may also be marked. For packages where marking of the entire SMD PIN number is not feasible due to space limitations, the manufacturer has the option of not marking the "5962-" on the device. For RHA product using this option, the RHA designator shall still be marked. Marking for device classes Q and V shall be in accordance with MIL-PRF-38535.

3.5.1 Certification/compliance mark. The certification mark for device classes Q and V shall be a "QML" or "Q" as required in MIL-PRF-38535.

3.6 Certificate of compliance. For device classes Q and V, a certificate of compliance shall be required from a QML-38535 listed manufacturer in order to supply to the requirements of this drawing (see 6.6.1 herein). The certificate of compliance submitted to DLA Land and Maritime-VA prior to listing as an approved source of supply for this drawing shall affirm that the manufacturer's product meets, for device classes Q and V, the requirements of MIL-PRF-38535 and herein.

3.7 Certificate of conformance. A certificate of conformance as required for device classes Q and V in MIL-PRF-38535 shall be provided with each lot of microcircuits delivered to this drawing.

<b>STANDARD MICROCIRCUIT DRAWING</b> DLA LAND AND MARITIME COLUMBUS, OHIO 43218-3990	SIZE <b>A</b>		<b>5962-07226</b>
		REVISION LEVEL F	SHEET 6

TABLE IA. Electrical performance characteristics.

Test	Symbol	Conditions <u>1</u> / <u>2</u> / -55°C ≤ TA ≤ +125°C unless otherwise specified	Group A subgroups	Device type	Limits		Unit
					Min	Max	
Static performance.		See figure 2.					
Integral non-linearity	INL	Over decimal codes 48 to 4047	1, 2, 3	01, 02	-8.0	+8.0	LSB
Differential non-linearity	DNL	VA = 2.7 V to 5.5 V	1, 2, 3	01, 02	-0.7	+1.0	LSB
Zero code error	ZE	IOUT = 0	1, 2, 3	01, 02		+15	mV
Full scale error	FSE	IOUT = 0	1, 2, 3	01, 02		-1.0	%FSR
Gain error	GE	All ones loaded to DAC register	1, 2, 3	01, 02		±1.0	%FSR
Output characteristics.							
Zero code output	ZCO	VA = 3 V, IOUT = 10 μA	1, 2, 3	01, 02		6	mV
		VA = 3 V, IOUT = 100 μA				10	
		VA = 5 V, IOUT = 10 μA				8	
		VA = 5 V, IOUT = 100 μA				9	
Full scale output	FSO	VA = 3 V, IOUT = 10 μA	1, 2, 3	01, 02	2.990		V
		VA = 3 V, IOUT = 100 μA			2.985		
		VA = 5 V, IOUT = 10 μA			4.985		
		VA = 5 V, IOUT = 100 μA			4.985		
DC output impedance			1,2,3	01, 02		16	Ω
Logic input .							
Input current	IIN		1, 2, 3	01, 02	-200	+200	nA
Input low voltage	VIL	VA = 5 V	1, 2, 3	01, 02		0.8	V
		VA = 3 V				0.5	
Input high voltage	VIH	VA = 5 V	1, 2, 3	01, 02	2.4		V
		VA = 3 V			2.1		

See footnotes at end of table.

**STANDARD  
MICROCIRCUIT DRAWING**  
DLA LAND AND MARITIME  
COLUMBUS, OHIO 43218-3990

SIZE  
**A**

REVISION LEVEL  
**F**

**5962-07226**

SHEET  
**7**

TABLE IA. Electrical performance characteristics – continued.

Test	Symbol	Conditions <u>1/</u> , <u>2/</u> -55°C ≤ TA ≤ +125°C unless otherwise specified	Group A subgroups	Device type	Limits		Unit
					Min	Max	
Power requirements.							
Supply current (output unloaded)	IA	Normal mode, VA = 5.5 V, fSCLK = 20 MHz	1, 2, 3	01, 02		270	μA
			1			325	
		Normal mode, VA = 3.6 V, fSCLK = 20 MHz	1, 2, 3		200		
			1		250		
		Normal mode, VA = 5.5 V, fSCLK = 10 MHz	1, 2, 3		230		
			1		300		
		Normal mode, VA = 3.6 V, fSCLK = 10 MHz	1, 2, 3		175		
			1		225		
		Normal mode, VA = 5.5 V, fSCLK = 0 MHz	1, 2, 3		190		
			1		275		
		Normal mode, VA = 3.6 V, fSCLK = 0 MHz	1, 2, 3		160		
			1		200		

See footnotes at end of table.

<b>STANDARD MICROCIRCUIT DRAWING</b> DLA LAND AND MARITIME COLUMBUS, OHIO 43218-3990	SIZE <b>A</b>		<b>5962-07226</b>
		REVISION LEVEL <b>F</b>	SHEET 8



TABLE IA. Electrical performance characteristics – continued.

Test	Symbol	Conditions <u>1/</u> , <u>2/</u> -55°C ≤ TA ≤ +125°C unless otherwise specified	Group A subgroups	Device type	Limits		Unit			
					Min	Max				
Power requirements - continued.										
Supply current (output unloaded)	IA	All PD modes, VA = 5.5 V, fSCLK = 20 MHz	1, 2, 3	01, 02		60	μA			
			M,D,P,L,R		1			125		
		All PD modes, VA = 3.6 V, fSCLK = 20 MHz	1, 2, 3		30					
			M,D,P,L,R	1		100				
		All PD modes, VA = 5.5 V, fSCLK = 10 MHz	1, 2, 3		40					
			M,D,P,L,R	1		115				
		All PD modes, VA = 3.6 V, fSCLK = 10 MHz	1, 2, 3		20					
			M,D,P,L,R	1		95				
		All PD modes, VA = 5.5 V, fSCLK = 0 MHz	1, 2, 3		1.0					
			M,D,P,L,R	1		100				
		All PD modes, VA = 3.6 V, fSCLK = 0 MHz	1, 2, 3		1.0					
			M,D,P,L,R	1		100				
		AC and timing characteristics.		See figure 3						
		SCLK frequency	fSCLK	<u>3/</u>	9, 10, 11	01, 02			20	MHz
Output voltage settling time	ts	FF0 to 00F code change, RL = ∞, CL ≤ 200 pF	9, 10, 11	01, 02		15	μs			
		FF0 to 00F code change, RL = ∞, CL = 500 pF				15				
		00Fh to FF0h code change, RL = ∞, CL ≤ 200 pF				15				
		00Fh to FF0h code change, RL = ∞, CL = 500 pF				15				

See footnotes at end of table.

<b>STANDARD MICROCIRCUIT DRAWING</b> DLA LAND AND MARITIME COLUMBUS, OHIO 43218-3990	SIZE <b>A</b>		<b>5962-07226</b>
		REVISION LEVEL <b>F</b>	SHEET 9

TABLE IA. Electrical performance characteristics – continued.

Test	Symbol	Conditions <u>1/</u> , <u>2/</u> -55°C ≤ TA ≤ +125°C unless otherwise specified	Group A subgroups	Device type	Limits		Unit
					Min	Max	
AC and timing characteristics - continued. See figure 3							
SCLK cycle time	1/fSCLK		9, 10, 11	01, 02	50		ns
SCLK high time	t <sub>H</sub>		9, 10, 11	01, 02	20		ns
SCLK low time	t <sub>L</sub>		9, 10, 11	01, 02	20		ns
Set-up time $\overline{\text{SYNC}}$ to SCLK rising edge	t <sub>SUCL</sub>		9, 10, 11	01, 02	0		ns
Data set-up time	t <sub>SUD</sub>		9, 10, 11	01, 02	6		ns
Data hold time	t <sub>DHD</sub>		9, 10, 11	01, 02	4.5		ns
SCLK fall to rise of $\overline{\text{SYNC}}$	t <sub>CS</sub>	VA = 5.5 V	9, 10, 11	01, 02	10		ns
		VA = 2.7 V			18		
$\overline{\text{SYNC}}$ high time	t <sub>SYNC</sub>	VA = 5.5 V	9, 10, 11	01, 02	37		ns
		VA = 2.7 V			36		

- 1/ RHA devices supplied to this drawing have been characterized through all levels M, D, P, L, and R of irradiation. However, this device is tested only at the “R” level. Pre and Post irradiation values are identical unless otherwise specified in Table IA. Testing is performed in accordance with MIL-STD-883 method 1019, condition A for device type 01 and condition D for device type 02. When performing post irradiation electrical measurements for any RHA level, TA = +25°C.
- 2/ Unless otherwise specified, VA = +2.7 V to +5.5 V, RL = ∞, CL = 200 pF to GND, fSCLK = 20 MHz, and input code range 48 to 4047.
- 3/ This parameter is guaranteed by design and/or characterization and is not tested in production.

TABLE IB. SEP test limits. 1/, 2/

Device types	Single event latch-up	Temperature (TC)	Bias condition maximum voltage VCC	Effective linear energy transfer (LET)
01, 02	No SEL	+125°C	5.5 V	≤ 120 MeV/(mg/cm <sup>2</sup> )

- 1/ For SEP test conditions, see 4.4.4.2 herein.
- 2/ Technology characterization and model verification supplemented by in-line data may be used in lieu of end of line testing. Test plan must be approved by the technical review board and qualifying activity.

<b>STANDARD MICROCIRCUIT DRAWING</b> DLA LAND AND MARITIME COLUMBUS, OHIO 43218-3990	SIZE <b>A</b>		<b>5962-07226</b>
		REVISION LEVEL <b>F</b>	SHEET 10

Device types	01 and 02
Case outline	Z
Terminal number	Terminal symbol
1	VA
2	NC
3	NC
4	VOUT
5	NC
6	NC
7	$\overline{\text{SYNC}}$
8	SCLK
9	DIN
10	GND

NC = No connection

FIGURE 1. Terminal connections.

<b>STANDARD MICROCIRCUIT DRAWING</b> DLA LAND AND MARITIME COLUMBUS, OHIO 43218-3990	SIZE <b>A</b>		<b>5962-07226</b>
		REVISION LEVEL <b>F</b>	SHEET 11

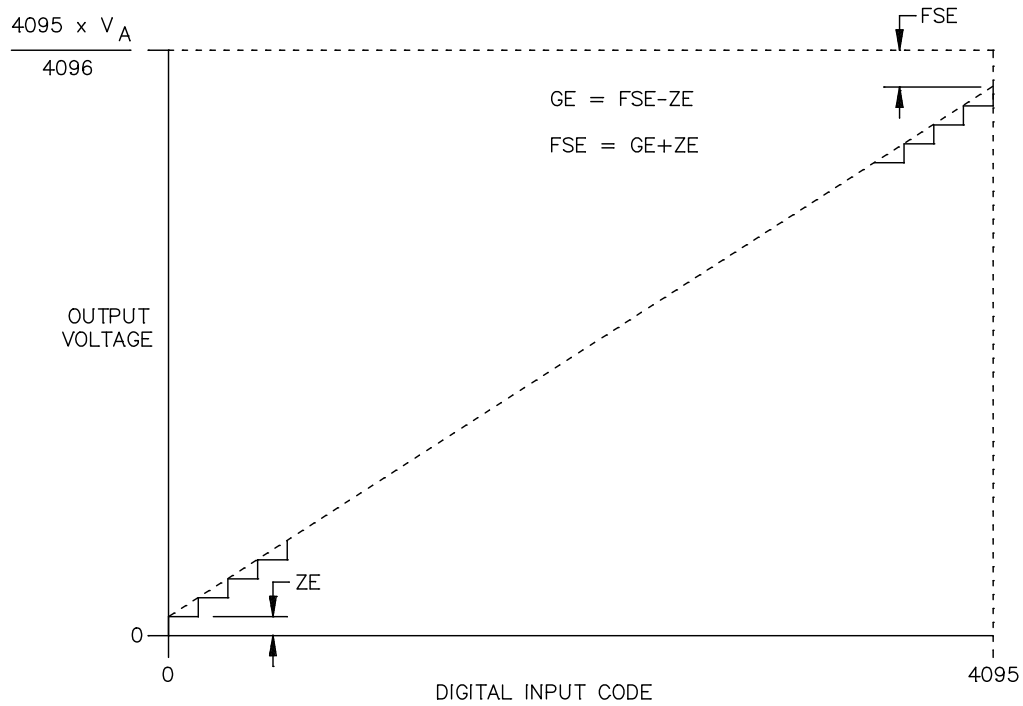

FIGURE 2. Input / output transfer characteristic.

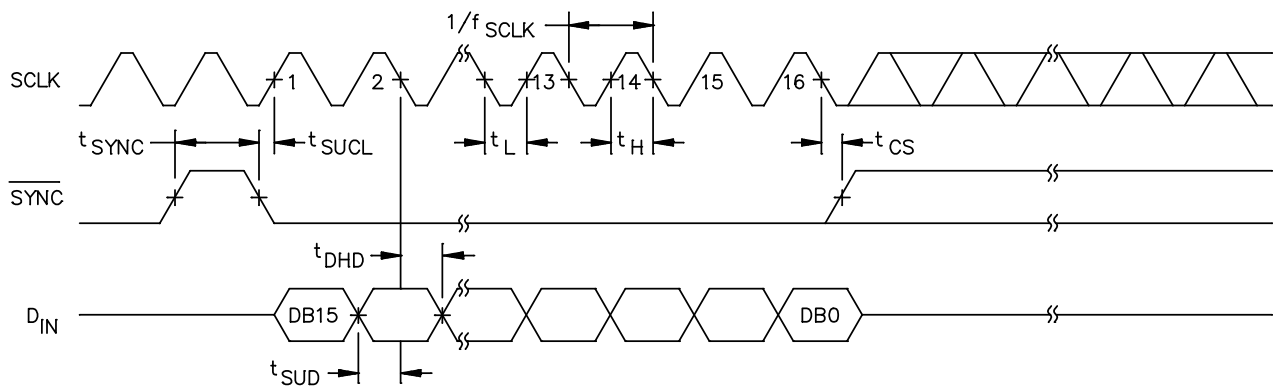

FIGURE 3. Timing waveforms.

**STANDARD  
MICROCIRCUIT DRAWING**  
 DLA LAND AND MARITIME  
 COLUMBUS, OHIO 43218-3990

SIZE  
**A**

**5962-07226**

REVISION LEVEL  
**F**

SHEET  
 12

4. VERIFICATION

4.1 Sampling and inspection. For device classes Q and V, sampling and inspection procedures shall be in accordance with MIL-PRF-38535 or as modified in the device manufacturer's Quality Management (QM) plan. The modification in the QM plan shall not affect the form, fit, or function as described herein.

4.2 Screening. For device classes Q and V, screening shall be in accordance with MIL-PRF-38535, and shall be conducted on all devices prior to qualification and technology conformance inspection.

4.2.1 Additional criteria for device classes Q and V.

- a. The burn-in test duration, test condition and test temperature, or approved alternatives shall be as specified in the device manufacturer's QM plan in accordance with MIL-PRF-38535. The burn-in test circuit shall be maintained under document revision level control of the device manufacturer's Technology Review Board (TRB) in accordance with MIL-PRF-38535 and shall be made available to the acquiring or preparing activity upon request. The test circuit shall specify the inputs, outputs, biases, and power dissipation, as applicable, in accordance with the intent specified in method 1015 of MIL-STD-883.
- b. Interim and final electrical test parameters shall be as specified in table IIA herein.
- c. Additional screening for device class V beyond the requirements of device class Q shall be as specified in MIL-PRF-38535, appendix B.

4.3 Qualification inspection for device classes Q and V. Qualification inspection for device classes Q and V shall be in accordance with MIL-PRF-38535. Inspections to be performed shall be those specified in MIL-PRF-38535 and herein for groups A, B, C, D, and E inspections (see 4.4.1 through 4.4.4).

4.4 Conformance inspection. Technology conformance inspection for classes Q and V shall be in accordance with MIL-PRF-38535 including groups A, B, C, D, and E inspections, and as specified herein.

4.4.1 Group A inspection.

- a. Tests shall be as specified in table IIA herein.
- b. Subgroups 4, 5, 6, 7, and 8 in table I, method 5005 of MIL-STD-883 shall be omitted.

4.4.2 Group C inspection. The group C inspection end-point electrical parameters shall be as specified in table IIA herein.

4.4.2.1 Additional criteria for device classes Q and V. The steady-state life test duration, test condition and test temperature, or approved alternatives shall be as specified in the device manufacturer's QM plan in accordance with MIL-PRF-38535. The test circuit shall be maintained under document revision level control by the device manufacturer's TRB in accordance with MIL-PRF-38535 and shall be made available to the acquiring or preparing activity upon request. The test circuit shall specify the inputs, outputs, biases, and power dissipation, as applicable, in accordance with the intent specified in method 1005 of MIL-STD-883.

4.4.3 Group D inspection. The group D inspection end-point electrical parameters shall be as specified in table IIA herein.

4.4.4 Group E inspection. Group E inspection is required only for parts intended to be marked as radiation hardness assured (see 3.5 herein).

- a. End-point electrical parameters shall be as specified in table IIA herein.
- b. For device classes Q and V, the devices or test vehicle shall be subjected to radiation hardness assured tests as specified in MIL-PRF-38535 for the RHA level being tested. All device classes must meet the postirradiation end-point electrical parameter limits as defined in table I at  $T_A = +25^{\circ}\text{C} \pm 5^{\circ}\text{C}$ , after exposure, to the subgroups specified in table IIA herein.

<b>STANDARD MICROCIRCUIT DRAWING</b> DLA LAND AND MARITIME COLUMBUS, OHIO 43218-3990	SIZE <b>A</b>		<b>5962-07226</b>
		REVISION LEVEL <b>F</b>	SHEET 13

TABLE IIA. Electrical test requirements.

Test requirements	Subgroups (in accordance with MIL-PRF-38535, table III)	
	Device class Q	Device class V
Interim electrical parameters (see 4.2)	1, 2, 3, 9, 10, 11	1, 2, 3, 9, 10, 11
Final electrical parameters (see 4.2)	1, 2, 3, <u>1/</u> 9, 10, 11	1, 2, 3, <u>1/</u> 9, 10, 11
Group A test requirements (see 4.4)	1, 2, 3, 9, 10, 11	1, 2, 3, 9, 10, 11
Group C end-point electrical parameters (see 4.4)	1, 2, 3, 9, 10, 11	1, 2, 3, <u>2/</u> 9, 10, 11
Group D end-point electrical parameters (see 4.4)	1, 2, 3	1, 2, 3
Group E end-point electrical parameters (see 4.4)	1, 9	1, 9

1/ PDA applies to subgroup 1.

2/ Delta limits as specified in table IIB shall be required where specified, and the delta limits shall be completed with reference to the zero hour electrical parameters (see table IA).

4.4.4.1 Total dose irradiation testing. Total dose irradiation testing shall be performed in accordance with MIL-STD-883 method 1019, condition A for device type 01, condition D for device type 02, and as specified herein.

4.4.4.1.1 Accelerated annealing test. Accelerated annealing tests shall be performed on all devices requiring a RHA level greater than 5 krad(Si). The post-anneal end-point electrical parameter limits shall be as specified in table IA herein and shall be the pre-irradiation end-point electrical parameter limit at 25°C ±5°C.

4.4.4.2 Single event phenomena (SEP). When specified in the purchase order or contract, SEP testing shall be performed on class V devices. SEP testing shall be performed on the Standard Evaluation Circuit (SEC) or alternate SEP test vehicle as approved by the qualifying activity at initial qualification and after any design or process changes which may affect the upset or latchup characteristics. Test four devices with zero failures. ASTM F1192 may be used as a guideline when performing SEP testing. The recommended test conditions for SEP are as follows:

- a. The ion beam angle of incidence shall be between normal to the die surface and 60° to the normal, inclusive (i.e. 0° ≤ angle ≤ 60°). No shadowing of the ion beam due to fixturing or package related affects is allowed.
- b. The fluence shall be ≥ 100 errors or ≥ 10<sup>7</sup> ions/cm<sup>2</sup>.
- c. The flux shall be between 10<sup>2</sup> and 10<sup>5</sup> ions/cm<sup>2</sup>/s. The cross-section shall be verified to be flux independent by measuring the cross-section at two flux rates which differ by at least an order of magnitude.
- d. The particle range shall be ≥ 20 micron in silicon.
- e. The test temperature shall be the maximum rated operating temperature +125°C.
- f. Bias conditions shall be V<sub>CC</sub> = 5.5 V for the latchup measurements.
- g. For SEL test limits, see Table IB herein.

<b>STANDARD MICROCIRCUIT DRAWING</b> DLA LAND AND MARITIME COLUMBUS, OHIO 43218-3990	SIZE <b>A</b>		<b>5962-07226</b>
		REVISION LEVEL <b>F</b>	SHEET 14

TABLE IIB. Operating life test delta parameters. TA = +25°C 1/

Parameters	Symbol	Conditions	Delta limits		Units
			Min	Max	
Integral non-linearity	INL		-2.0	+2.0	LSB
Output voltage settling time	ts		-5	+5	μs
Supply current (output unloaded)	IA	Normal mode, VA = 5.5 V, fSCLK = 20 MHz	-10	+10	μA
		Normal mode, VA = 3.6 V, fSCLK = 20 MHz	-6	+6	
		Normal mode, VA = 5.5 V, fSCLK = 10 MHz	-10	+10	
		Normal mode, VA = 3.6 V, fSCLK = 10 MHz	-6	+6	
		Normal mode, VA = 5.5 V, fSCLK = 0 MHz	-8	+8	
		Normal mode, VA = 3.6 V, fSCLK = 0 MHz	-6	+6	
		All PD modes, VA = 5.5 V, fSCLK = 20 MHz	-2	+2	
		All PD modes, VA = 3.6 V, fSCLK = 20 MHz	-1	+1	
		All PD modes, VA = 5.5 V, fSCLK = 10 MHz	-1	+1	
		All PD modes, VA = 3.6 V, fSCLK = 10 MHz	-1	+1	
		All PD modes, VA = 5.5 V, fSCLK = 0 MHz	-0.1	+0.1	
		All PD modes, VA = 3.6 V, fSCLK = 0 MHz	-0.1	+0.1	

1/ These parameters are worse case drift. Deltas are performed at room temperature post operation life. For all other parameters, no deltas are required.

**STANDARD  
MICROCIRCUIT DRAWING**  
DLA LAND AND MARITIME  
COLUMBUS, OHIO 43218-3990

SIZE  
**A**

**5962-07226**

REVISION LEVEL  
**F**

SHEET  
15

5. PACKAGING

5.1 Packaging requirements. The requirements for packaging shall be in accordance with MIL-PRF-38535 for device classes Q and V.

6. NOTES

6.1 Intended use. Microcircuits conforming to this drawing are intended for use for Government microcircuit applications (original equipment), design applications, and logistics purposes.

6.1.1 Replaceability. Microcircuits covered by this drawing will replace the same generic device covered by a contractor prepared specification or drawing.

6.2 Configuration control of SMD's. All proposed changes to existing SMD's will be coordinated with the users of record for the individual documents. This coordination will be accomplished using DD Form 1692, Engineering Change Proposal.

6.3 Record of users. Military and industrial users should inform DLA Land and Maritime when a system application requires configuration control and which SMD's are applicable to that system. DLA Land and Maritime will maintain a record of users and this list will be used for coordination and distribution of changes to the drawings. Users of drawings covering microelectronic devices (FSC 5962) should contact DLA Land and Maritime-VA, telephone (614) 692-8108.

6.4 Comments. Comments on this drawing should be directed to DLA Land and Maritime-VA, Columbus, Ohio 43218-3990, or telephone (614) 692-0540.

6.5 Abbreviations, symbols, and definitions. The abbreviations, symbols, and definitions used herein are defined in MIL-PRF-38535 and MIL-HDBK-1331.

6.6 Sources of supply.

6.6.1 Sources of supply for device classes Q and V. Sources of supply for device classes Q and V are listed in MIL-HDBK-103 and QML-38535. The vendors listed in MIL-HDBK-103 and QML-38535 have submitted a certificate of compliance (see 3.6 herein) to DLA Land and Maritime-VA and have agreed to this drawing.

6.7 Additional information. When applicable, a copy of the following additional data shall be maintained and available from the device manufacturer:

- a. RHA upset levels.
- b. Test conditions (SEL).
- c. Occurrence of latchup (SEL).

<b>STANDARD MICROCIRCUIT DRAWING</b> DLA LAND AND MARITIME COLUMBUS, OHIO 43218-3990	SIZE <b>A</b>		<b>5962-07226</b>
		REVISION LEVEL F	SHEET 16



APPENDIX A  
APPENDIX A FORMS A PART OF SMD 5962-07226

A.1 SCOPE

A.1.1 Scope. This appendix establishes minimum requirements for microcircuit die to be supplied under the Qualified Manufacturers List (QML) Program. QML microcircuit die meeting the requirements of MIL-PRF-38535 and the manufacturers approved QM plan for use in monolithic microcircuits, multi-chip modules (MCMs), hybrids, electronic modules, or devices using chip and wire designs in accordance with MIL-PRF-38534 are specified herein. Two product assurance classes consisting of military high reliability (device class Q) and space application (device class V) are reflected in the Part or Identification Number (PIN). When available, a choice of Radiation Hardness Assurance (RHA) levels are reflected in the PIN.

A.1.2 PIN. The PIN is as shown in the following example:

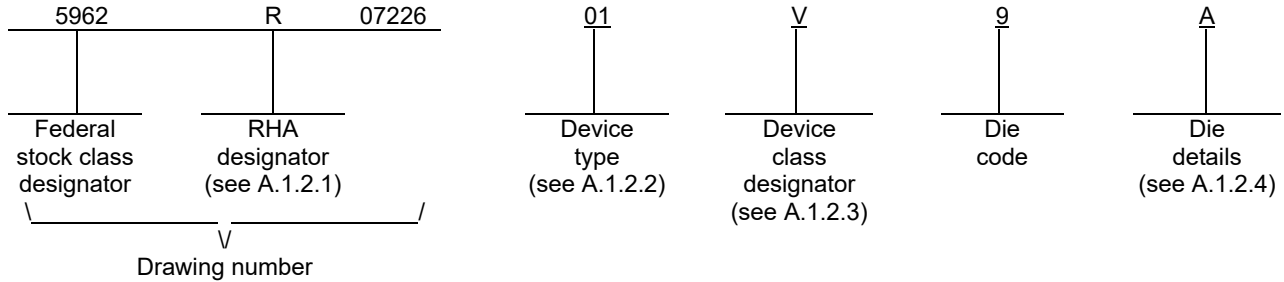

A.1.2.1 RHA designator. Device classes Q and V RHA identified die meet the MIL-PRF-38535 specified RHA levels. A dash (-) indicates a non-RHA die.

A.1.2.2 Device types. The device types identify the circuit function as follows:

<u>Device type</u>	<u>Generic number</u>	<u>Circuit function</u>
01	DAC121S101	12 bit digital-to-analog converter
02	DAC121S101	12 bit digital-to-analog converter

A.1.2.3 Device class designator.

<u>Device class</u>	<u>Device requirements documentation</u>
Q or V	Certification and qualification to the die requirements of MIL-PRF-38535

<b>STANDARD MICROCIRCUIT DRAWING</b> DLA LAND AND MARITIME COLUMBUS, OHIO 43218-3990	SIZE <b>A</b>		<b>5962-07226</b>
		REVISION LEVEL F	SHEET 17

APPENDIX A  
APPENDIX A FORMS A PART OF SMD 5962-07226

A.1.2.4 Die details. The die details designation is a unique letter which designates the die's physical dimensions, bonding pad location(s) and related electrical function(s), interface materials, and other assembly related information, for each product and variant supplied to this appendix.

A.1.2.4.1 Die physical dimensions.

<u>Die type</u>	<u>Figure number</u>
01, 02	A-1

A.1.2.4.2 Die bonding pad locations and electrical functions.

<u>Die type</u>	<u>Figure number</u>
01, 02	A-1

A.1.2.4.3 Interface materials.

<u>Die type</u>	<u>Figure number</u>
01, 02	A-1

A.1.2.4.4 Assembly related information.

<u>Die type</u>	<u>Figure number</u>
01, 02	A-1

A.1.3 Absolute maximum ratings. See paragraph 1.3 herein for details.

A.1.4 Recommended operating conditions. See paragraph 1.4 herein for details.

<b>STANDARD MICROCIRCUIT DRAWING</b> DLA LAND AND MARITIME COLUMBUS, OHIO 43218-3990	SIZE <b>A</b>		<b>5962-07226</b>
		REVISION LEVEL F	SHEET 18

APPENDIX A  
APPENDIX A FORMS A PART OF SMD 5962-07226

A.2 APPLICABLE DOCUMENTS.

A.2.1 Government specification, standards, and handbooks. The following specification, standards, and handbooks form a part of this drawing to the extent specified herein. Unless otherwise specified, the issues of these documents are those cited in the solicitation or contract.

DEPARTMENT OF DEFENSE SPECIFICATION

MIL-PRF-38535 - Integrated Circuits, Manufacturing, General Specification for.

DEPARTMENT OF DEFENSE STANDARD

MIL-STD-883 - Test Method Standard Microcircuits.

DEPARTMENT OF DEFENSE HANDBOOKS

MIL-HDBK-103 - List of Standard Microcircuit Drawings.

MIL-HDBK-780 - Standard Microcircuit Drawings.

(Copies of these documents are available online at <https://quicksearch.dla.mil>.)

A.2.2 Order of precedence. In the event of a conflict between the text of this drawing and the references cited herein, the text of this drawing takes precedence. Nothing in this document, however, supersedes applicable laws and regulations unless a specific exemption has been obtained.

A.3 REQUIREMENTS

A.3.1 Item requirements. The individual item requirements for device classes Q and V shall be in accordance with MIL-PRF-38535 and as specified herein or as modified in the device manufacturer's Quality Management (QM) plan. The modification in the QM plan shall not affect the form, fit, or function as described herein.

A.3.2 Design, construction and physical dimensions. The design, construction, and physical dimensions shall be as specified in MIL-PRF-38535 and herein and the manufacturer's QM plan for device classes Q and V.

A.3.2.1 Die physical dimensions. The die physical dimensions shall be as specified in A.1.2.4.1 and on figure A-1.

A.3.2.2 Die bonding pad locations and electrical functions. The die bonding pad locations and electrical functions shall be as specified in A.1.2.4.2 and on figure A-1.

A.3.2.3 Interface materials. The interface materials for the die shall be as specified in A.1.2.4.3 and on figure A-1.

A.3.2.4 Assembly related information. The assembly related information shall be as specified in A.1.2.4.4 and on figure A-1.

A.3.2.5 Radiation exposure circuit. The radiation exposure circuit shall be as defined in paragraph 3.2.5 herein.

A.3.3 Electrical performance characteristics and post-irradiation parameter limits. Unless otherwise specified herein, the electrical performance characteristics and post-irradiation parameter limits are as specified in table IA of the body of this document.

A.3.4 Electrical test requirements. The wafer probe test requirements shall include functional and parametric testing sufficient to make the packaged die capable of meeting the electrical performance requirements in table IA.

A.3.5 Marking. As a minimum, each unique lot of die, loaded in single or multiple stack of carriers, for shipment to a customer, shall be identified with the wafer lot number, the certification mark, the manufacturer's identification and the PIN listed in A.1.2 herein. The certification mark shall be a "QML" or "Q" as required by MIL-PRF-38535.

<b>STANDARD MICROCIRCUIT DRAWING</b> DLA LAND AND MARITIME COLUMBUS, OHIO 43218-3990	SIZE <b>A</b>		<b>5962-07226</b>
		REVISION LEVEL F	SHEET 19

APPENDIX A  
APPENDIX A FORMS A PART OF SMD 5962-07226

A.3.6 Certification of compliance. For device classes Q and V, a certificate of compliance shall be required from a QML-38535 listed manufacturer in order to supply to the requirements of this drawing (see A.6.4 herein). The certificate of compliance submitted to DLA Land and Maritime -VA prior to listing as an approved source of supply for this appendix shall affirm that the manufacturer's product meets, for device classes Q and V, the requirements of MIL-PRF-38535 and the requirements herein.

A.3.7 Certificate of conformance. A certificate of conformance as required for device classes Q and V in MIL-PRF-38535 shall be provided with each lot of microcircuit die delivered to this drawing.

A.4 VERIFICATION

A.4.1 Sampling and inspection. For device classes Q and V, die sampling and inspection procedures shall be in accordance with MIL-PRF-38535 or as modified in the device manufacturer's Quality Management (QM) plan. The modifications in the QM plan shall not affect the form, fit, or function as described herein.

A.4.2 Screening. For device classes Q and V, screening shall be in accordance with MIL-PRF-38535, and as defined in the manufacturer's QM plan. As a minimum, it shall consist of:

- a. Wafer lot acceptance for class V product using the criteria defined in MIL-STD-883, method 5007.
- b. 100% wafer probe (see paragraph A.3.4 herein).
- c. 100% internal visual inspection to the applicable class Q or V criteria defined in MIL-STD-883, method 2010 or the alternate procedures allowed in MIL-STD-883, method 5004.

A.4.3 Conformance inspection.

A.4.3.1 Group E inspection. Group E inspection is required only for parts intended to be identified as radiation assured (see A.3.5 herein). RHA levels for device classes Q and V shall be as specified in MIL-PRF-38535. End point electrical testing of packaged die shall be as specified in table IIA herein. Group E tests and conditions are as specified in paragraphs 4.4.4, 4.4.4.1, 4.4.4.1.1, and 4.4.4.2 herein.

A.5 DIE CARRIER

A.5.1 Die carrier requirements. The requirements for the die carrier shall be accordance with the manufacturer's QM plan or as specified in the purchase order by the acquiring activity. The die carrier shall provide adequate physical, mechanical and electrostatic protection.

A.6 NOTES

A.6.1 Intended use. Microcircuit die conforming to this drawing are intended for use in microcircuits built in accordance with MIL-PRF-38535 or MIL-PRF-38534 for government microcircuit applications (original equipment), design applications, and logistics purposes.

A.6.2 Comments. Comments on this appendix should be directed to DLA Land and Maritime -VA, Columbus, Ohio, 43218-3990 or telephone (614)-692-0540.

A.6.3 Abbreviations, symbols, and definitions. The abbreviations, symbols, and definitions used herein are defined in MIL-PRF-38535 and MIL-HDBK-1331.

A.6.4 Sources of supply for device classes Q and V. Sources of supply for device classes Q and V are listed in QML-38535. The vendors listed within MIL-HDBK-103 and QML-38535 have submitted a certificate of compliance (see A.3.6 herein) to DLA Land and Maritime -VA and have agreed to this drawing.

<b>STANDARD MICROCIRCUIT DRAWING</b> DLA LAND AND MARITIME COLUMBUS, OHIO 43218-3990	SIZE <b>A</b>		<b>5962-07226</b>
		REVISION LEVEL F	SHEET 20

APPENDIX A  
 APPENDIX A FORMS A PART OF SMD 5962-07226

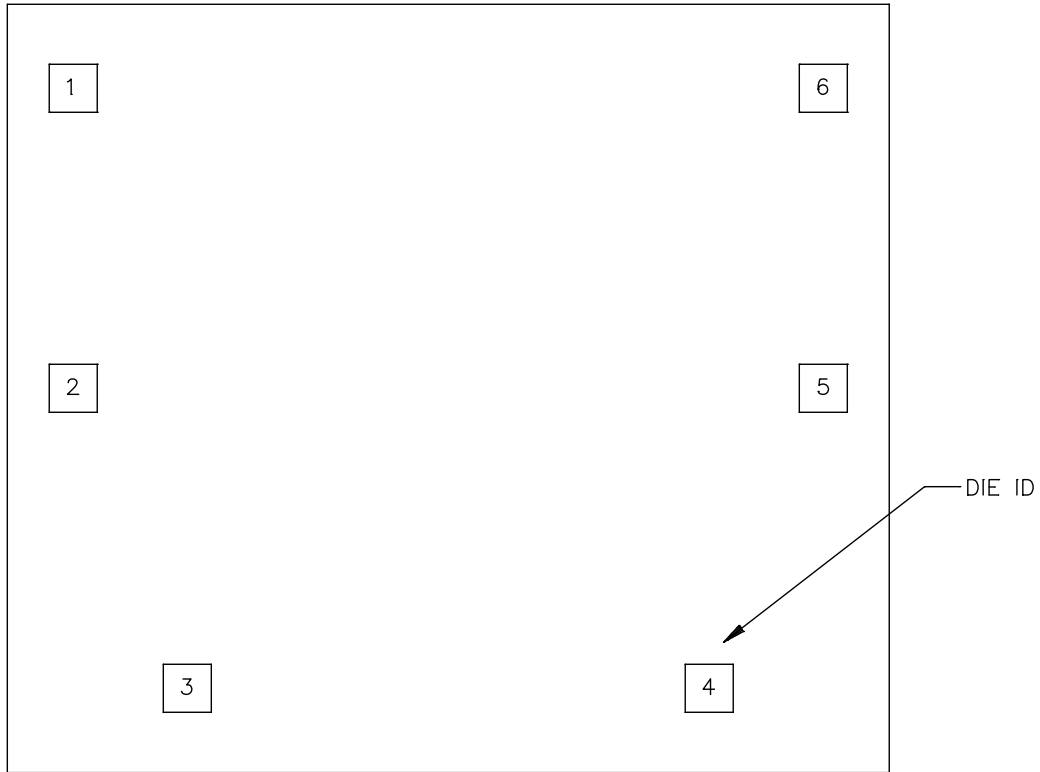

FIGURE A-1. Die bonding pad locations and electrical functions.

<b>STANDARD          MICROCIRCUIT DRAWING</b> DLA LAND AND MARITIME COLUMBUS, OHIO 43218-3990	SIZE <b>A</b>		<b>5962-07226</b>
		REVISION LEVEL <b>F</b>	SHEET 21

APPENDIX A  
APPENDIX A FORMS A PART OF SMD 5962-07226

Die bond pad coordinate location (A-step)

Terminal symbol	Pad number	X/Y coordinates		Pad size		
		X	Y	X	Y	
VOUT	1	449	564	77	x	77
$\overline{\text{SYNC}}$	2	-3	564	77	x	77
SCLK	3	-439	395	77	x	77
DIN	4	-416	-410	77	x	77
GND	5	73	-564	77	x	77
VA	6	466	-564	77	x	77

Referenced to die center, coordinates in  $\mu\text{m}$ . NC = no connection. NU = not used.

Die bonding pad locations and electrical functions

Die physical dimensions.

Die size: 1333.50  $\mu\text{m}$  (52.5 mils) x 1163.32  $\mu\text{m}$  (45.8 mils)

Die thickness: 304.8  $\mu\text{m}$  nominal

Interface materials.

Top metallization: Al 0.5% CU

Backside metallization: Bare back

Glassivation.

Type:

Thickness:

Substrate:

Assembly related information.

Substrate potential:

Special assembly instructions: None

FIGURE A-1. Die bonding pad locations and electrical functions - continued.

<b>STANDARD MICROCIRCUIT DRAWING</b> DLA LAND AND MARITIME COLUMBUS, OHIO 43218-3990	SIZE <b>A</b>		<b>5962-07226</b>
		REVISION LEVEL F	SHEET 22

STANDARD MICROCIRCUIT DRAWING BULLETIN

DATE: 21-05-14

Approved sources of supply for SMD 5962-07226 are listed below for immediate acquisition information only and shall be added to MIL-HDBK-103 and QML-38535 during the next revision. MIL-HDBK-103 and QML-38535 will be revised to include the addition or deletion of sources. The vendors listed below have agreed to this drawing and a certificate of compliance has been submitted to and accepted by DLA Land and Maritime-VA. This information bulletin is superseded by the next dated revision of MIL-HDBK-103 and QML-38535. DLA Land and Maritime maintains an online database of all current sources of supply at <https://landandmaritimeapps.dla.mil/programs/smcr/>.

Standard microcircuit drawing PIN <u>1/</u>	Vendor CAGE number	Vendor similar PIN <u>2/</u>
5962R0722601VZA	01295	DAC121S101WGRQV
5962R0722602VZA	01295	DAC121S101WGRLV
5962R0722601V9A	01295	DAC121S101-MDR
5962R0722602V9A	01295	DAC121S101-MDE

1/ The lead finish shown for each PIN representing a hermetic package is the most readily available from the manufacturer listed for that part. If the desired lead finish is not listed contact the vendor to determine its availability.

2/ Caution. Do not use this number for item acquisition. Items acquired to this number may not satisfy the performance requirements of this drawing.

Vendor CAGE  
number

01295

Vendor name  
and address

Texas Instruments, Inc.  
Semiconductor Group  
8505 Forest Ln.  
PO Box 660199  
Dallas, TX 75243

The information contained herein is disseminated for convenience only and the Government assumes no liability whatsoever for any inaccuracies in the information bulletin.