

REVISIONS

LTR	DESCRIPTION	DATE (YR-MO-DA)	APPROVED
A	Add device type 02 and RHA designator "R" requirements. Make changes to 1.2.2, 1.4, and Table I. Make a change to case outline X pin 32 under Figure 2. Add paragraphs 1.5, 4.4.4.1, and Table IIB. Delete AV _{CC} , DV _{CC} , and t _{CMIN} tests as specified under Table I. - ro	08-10-31	R. HEBER
B	Add device type 03 tested at low dose rate. Make change to paragraphs 1.2.2, 1.4, and 1.5. Make changes to footnotes 1/, 2/, and 3/ as specified under Table I. Make change to Table IIB and paragraph 4.4.4.1. -rrp	11-06-14	C. SAFFLE
C	Add single event latchup (SEL) testing information for device types 02 and 03. Add paragraph 1.4.1. Delete device class M references. - ro	13-06-18	C. SAFFLE
D	Add note under Figure 2 terminal connections. - ro	15-12-10	C. SAFFLE



REV																				
SHEET																				
REV	D	D																		
SHEET	15	16																		

REV STATUS OF SHEETS	REV	D	D	D	D	D	D	D	D	D	D	D	D	D	D	D	D	D
	SHEET	1	2	3	4	5	6	7	8	9	10	11	12	13	14			

PMIC N/A	PREPARED BY DAN WONNELL	DLA LAND AND MARITIME COLUMBUS, OHIO 43218-3990 http://www.landandmaritime.dla.mil																	
STANDARD MICROCIRCUIT DRAWING THIS DRAWING IS AVAILABLE FOR USE BY ALL DEPARTMENTS AND AGENCIES OF THE DEPARTMENT OF DEFENSE AMSC N/A	CHECKED BY RAYMOND MONNIN																		
	APPROVED BY RAYMOND MONNIN	MICROCIRCUIT, DIGITAL-LINEAR, A/D CONVERTER, 14-BIT, 80 MSPS, MONOLITHIC SILICON																	
	DRAWING APPROVAL DATE 04-10-25																		
	REVISION LEVEL D	SIZE A	CAGE CODE 67268	5962-04230															
		SHEET		1 OF 16															

1. SCOPE

1.1 Scope. This drawing documents two product assurance class levels consisting of high reliability (device class Q) and space application (device class V). A choice of case outlines and lead finishes are available and are reflected in the Part or Identifying Number (PIN). When available, a choice of Radiation Hardness Assurance (RHA) levels is reflected in the PIN.

1.2 PIN. The PIN is as shown in the following example:

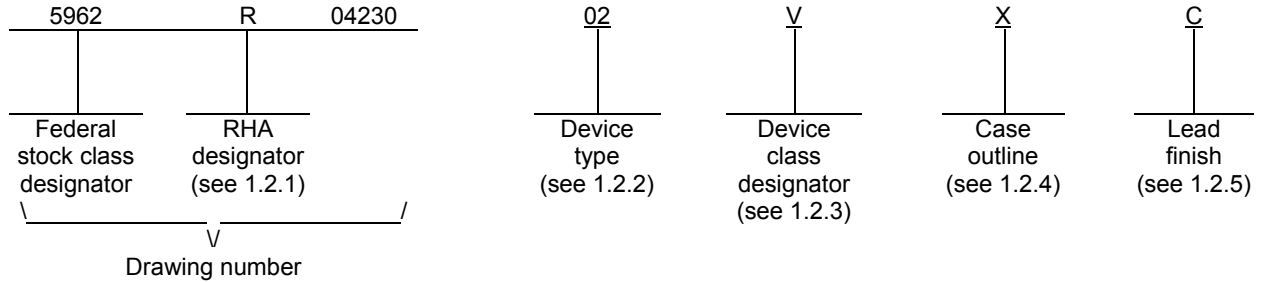

1.2.1 RHA designator. Device classes Q and V RHA marked devices meet the MIL-PRF-38535 specified RHA levels and are marked with the appropriate RHA designator. A dash (-) indicates a non-RHA device.

1.2.2 Device type(s). The device type(s) identify the circuit function as follows:

<u>Device type</u>	<u>Generic number</u>	<u>Operating temperature</u>	<u>Circuit function</u>
01	AD6645	$-35^{\circ}\text{C} \leq T_C \leq +85^{\circ}\text{C}$	A/D converter, 14-bit, 80 MSPS
02	AD6645	$-55^{\circ}\text{C} \leq T_A \leq +125^{\circ}\text{C}$	Radiation hardened A/D converter, 14-bit, 80 MSPS
03	AD6645	$-55^{\circ}\text{C} \leq T_A \leq +125^{\circ}\text{C}$	Radiation hardened A/D converter, 14-bit, 80 MSPS

1.2.3 Device class designator. The device class designator is a single letter identifying the product assurance level as follows:

<u>Device class</u>	<u>Device requirements documentation</u>
Q or V	Certification and qualification to MIL-PRF-38535

1.2.4 Case outline(s). The case outline(s) are as designated in MIL-STD-1835 and as follows:

<u>Outline letter</u>	<u>Descriptive designator</u>	<u>Terminals</u>	<u>Package style</u>
X	See figure 1	52	Quad flat pack with non-conductive tie bars

1.2.5 Lead finish. The lead finish is as specified in MIL-PRF-38535 for device classes Q and V.

STANDARD MICROCIRCUIT DRAWING DLA LAND AND MARITIME COLUMBUS, OHIO 43218-3990	SIZE A		5962-04230
		REVISION LEVEL D	SHEET 2

1.3 Absolute maximum ratings. ^{1/}

Analog supply voltage (AV _{CC})	0 V dc to 7 V dc
Digital supply voltage (DV _{CC})	0 V dc to 7 V dc
Analog input voltage	0 V dc to AV _{CC}
Analog input current	25 mA
Digital input voltage	0 V dc to AV _{CC}
Digital output current	4 mA
Junction temperature (T _J)	+175°C
Lead temperature (soldering, 10 seconds)	+300°C
Storage temperature range	-65°C to +150°C
Thermal resistance, junction-to-case (θ _{JC})	7.2°C/W

1.4 Recommended operating conditions.

Analog supply voltage (AV _{CC})	4.75 V dc to 5.25 V dc
Digital supply voltage (DV _{CC})	3.0 V dc to 3.6 V dc
Case operating temperature range (T _C) for device type 01	-35°C to +85°C
Ambient operating temperature range (T _A) for device types 02 and 03	-55°C to +125°C

1.4.1 Operating performance characteristics.

AC performance: T_A = +25°C, AV_{CC} = 5 V, DV_{CC} = 3.3 V, f_C = 82 MSPS, f_N = 175 MHz.

Signal to noise ratio (SNR) at -1 dBFS	71 dB
Signal to noise and distortion (SINAD) at -1 dBFS	70 dB
Worst case second or third harmonic (2nd to 3rd) at -1 dBFS	-78 dBc
Worst case fourth or higher harmonic (4th plus) at -1 dBFS	-91 dBc

1.5 Radiation features:

Maximum total dose available (dose rate = 50 – 300 rads(Si)/s):	
Device type 02	100 krad(Si) ^{2/}
Maximum total dose available (dose rate ≤ 10 mrad(Si)/s):	
Device type 03	50 krad(Si) ^{3/}
Single event phenomenon (SEP):	
No single event latchup (SEL) occurs at effective linear energy transfer (LET) (see 4.4.4.2):	
Device types 02 and 03:	≤ 80 MeV-cm ² /mg ^{4/}

- ^{1/} Stresses above the absolute maximum rating may cause permanent damage to the device. Extended operation at the maximum levels may degrade performance and affect reliability.
- ^{2/} These parts may be dose rate sensitive in a space environment and may demonstrate enhanced low dose rate effects. Radiation end point limits for the noted parameters are guaranteed only for the conditions as specified in MIL-STD-883, method 1019, condition A.
- ^{3/} For device type 03, radiation end point limits for the noted parameters are guaranteed for the conditions specified in MIL-STD-883, method 1019, condition D.
- ^{4/} Limits are characterized at initial qualification and after any design or process changes that may affect the SEP characteristics, but are not production lot tested unless specified by the customer through the purchase order or contract. For more information on single event effect (SEE) test results, customers are requested to contact the manufacturer.

STANDARD MICROCIRCUIT DRAWING DLA LAND AND MARITIME COLUMBUS, OHIO 43218-3990	SIZE A		5962-04230
		REVISION LEVEL D	SHEET 3

2. APPLICABLE DOCUMENTS

2.1 Government specification, standards, and handbooks. The following specification, standards, and handbooks form a part of this drawing to the extent specified herein. Unless otherwise specified, the issues of these documents are those cited in the solicitation or contract.

DEPARTMENT OF DEFENSE SPECIFICATION

MIL-PRF-38535 - Integrated Circuits, Manufacturing, General Specification for.

DEPARTMENT OF DEFENSE STANDARDS

MIL-STD-883 - Test Method Standard Microcircuits.
 MIL-STD-1835 - Interface Standard Electronic Component Case Outlines.

DEPARTMENT OF DEFENSE HANDBOOKS

MIL-HDBK-103 - List of Standard Microcircuit Drawings.
 MIL-HDBK-780 - Standard Microcircuit Drawings.

(Copies of these documents are available online at <http://quicksearch.dla.mil> or from the Standardization Document Order Desk, 700 Robbins Avenue, Building 4D, Philadelphia, PA 19111-5094.)

2.2 Non-Government publications. The following document(s) form a part of this document to the extent specified herein. Unless otherwise specified, the issues of these documents are those cited in the solicitation or contract.

ASTM INTERNATIONAL (ASTM)

ASTM F1192 - Standard Guide for the Measurement of Single Event Phenomena (SEP) Induced by Heavy Ion Irradiation of semiconductor Devices.

(Copies of these documents are available online at <http://www.astm.org> or from ASTM International, 100 Barr Harbor Drive, P.O. Box C700, West Conshohocken, PA, 19428-2959).

2.3 Order of precedence. In the event of a conflict between the text of this drawing and the references cited herein, the text of this drawing takes precedence. Nothing in this document, however, supersedes applicable laws and regulations unless a specific exemption has been obtained.

STANDARD MICROCIRCUIT DRAWING DLA LAND AND MARITIME COLUMBUS, OHIO 43218-3990	SIZE A		5962-04230
		REVISION LEVEL D	SHEET 4

3. REQUIREMENTS

3.1 Item requirements. The individual item requirements for device classes Q and V shall be in accordance with MIL-PRF-38535 as specified herein, or as modified in the device manufacturer's Quality Management (QM) plan. The modification in the QM plan shall not affect the form, fit, or function as described herein.

3.2 Design, construction, and physical dimensions. The design, construction, and physical dimensions shall be as specified in MIL-PRF-38535 and herein for device classes Q and V.

3.2.1 Case outline. The case outline shall be in accordance with 1.2.4 herein and figure 1.

3.2.2 Terminal connections. The terminal connections shall be as specified on figure 2.

3.2.3 Timing waveforms. The timing waveforms shall be as specified on figure 3.

3.2.4 Radiation exposure circuit. The radiation exposure circuit shall be maintained by the manufacturer under document revision level control and shall be made available to the preparing and acquiring activity upon request.

3.3 Electrical performance characteristics and postirradiation parameter limits. Unless otherwise specified herein, the electrical performance characteristics and postirradiation parameter limits are as specified in table IA and shall apply over the full case operating temperature range for device type 01 and ambient operating temperature range for device types 02 and 03.

3.4 Electrical test requirements. The electrical test requirements shall be the subgroups specified in table IIA. The electrical tests for each subgroup are defined in table I.

3.5 Marking. The part shall be marked with the PIN listed in 1.2 herein. In addition, the manufacturer's PIN may also be marked. For packages where marking of the entire SMD PIN number is not feasible due to space limitations, the manufacturer has the option of not marking the "5962-" on the device. For RHA product using this option, the RHA designator shall still be marked. Marking for device classes Q and V shall be in accordance with MIL-PRF-38535.

3.5.1 Certification/compliance mark. The certification mark for device classes Q and V shall be a "QML" or "Q" as required in MIL-PRF-38535.

3.6 Certificate of compliance. For device classes Q and V, a certificate of compliance shall be required from a QML-38535 listed manufacturer in order to supply to the requirements of this drawing (see 6.6.1 herein). The certificate of compliance submitted to DLA Land and Maritime-VA prior to listing as an approved source of supply for this drawing shall affirm that the manufacturer's product meets, for device classes Q and V, the requirements of MIL-PRF-38535 and herein.

3.7 Certificate of conformance. A certificate of conformance as required for device classes Q and V in MIL-PRF-38535 shall be provided with each lot of microcircuits delivered to this drawing.

STANDARD MICROCIRCUIT DRAWING DLA LAND AND MARITIME COLUMBUS, OHIO 43218-3990	SIZE A		5962-04230
		REVISION LEVEL D	SHEET 5

TABLE IA. Electrical performance characteristics.

Test	Symbol	Conditions <u>1/ 2/ 3/</u> AV _{CC} = 5 V, DV _{CC} = 3.3 V, f _c = 80 MSPS unless otherwise specified	Group A subgroups	Device type	Limits		Unit	
					Min	Max		
Resolution	RES	<u>4/ 5/</u>	1, 2, 3	All	14		Bits	
Offset error	O _E		1, 2, 3	All	-10	+10	mV	
			M,D,P,L,R	1	02	-10		+10
			M,D,P,L	1	03	-10		+10
Gain error	A _E		1, 2, 3	01	-10	+10	%FS	
			1	02, 03	-10	+10		
			2,3		-14	+14		
			M,D,P,L,R	1	02	-10		+10
			M,D,P,L	1	03	-10		+10
			Analog supply current	I _{AVCC}	AV _{CC} = 5.0 V	1, 2, 3		All
		M,D,P,L,R	1	02		320		
		M,D,P,L	1	03		320		
Digital supply current	I _{DVCC}	DV _{CC} = 3.3 V	1, 2, 3	All		45	mA	
			M,D,P,L,R	1	02			45
			M,D,P,L	1	03			45
Power consumption	P _D	<u>4/</u>	1, 2, 3	All		1.75	W	
Differential input voltage	V _{DIFF}	<u>5/</u>	1, 2, 3	01	0.4		V _{p-p}	
Output voltage, logic "1"	V _{OH}	DV _{CC} = 3.3 V, I _{OH} = 0 <u>5/</u>	1, 2, 3	01	2.85		V	
		DV _{CC} = 3.3 V, I _{OH} = 0 <u>4/</u>		02, 03	2.8			
Output voltage, logic "0"	V _{OL}	DV _{CC} = 3.3 V, I _{OL} = 0 <u>5/</u>	1, 2, 3	01		0.5	V	
		DV _{CC} = 3.3 V, I _{OL} = 0 <u>4/</u>		02, 03		0.5		
No missing codes		<u>4/</u>	4,5,6	02, 03	0	0		

See footnotes at end of table.

STANDARD MICROCIRCUIT DRAWING DLA LAND AND MARITIME COLUMBUS, OHIO 43218-3990	SIZE A		5962-04230
		REVISION LEVEL D	SHEET 6

TABLE IA. Electrical performance characteristics – continued.

Test	Symbol	Conditions <u>1/ 2/ 3/</u> AV _{CC} = 5 V, DV _{CC} = 3.3 V, f _c = 80 MSPS unless otherwise specified	Group A subgroups	Device type	Limits		Unit			
					Min	Max				
Differential non-linearity	DNL	<u>6/</u>	4,5	02, 03	-1	1.5	LSB			
			6		-1	2.0				
			M,D,P,L,R	4	02	-1		1.5		
			M,D,P,L	4	03	-1		1.5		
Signal to noise ratio (SNR) at -1 dBFS	SNR	70.1 MHz <u>4/ 6/</u>	4, 5, 6	01	68.5		dB			
		150.1 MHz <u>4/ 6/</u>			67					
		30 MHz <u>4/ 6/</u>	4,5	02, 03	72					
			6		70.5					
		70 MHz <u>4/ 6/</u>	4,5		71.5					
			6		70					
		Signal to noise ratio and distortion (SINAD) at -1 dBFS	SINAD	70.1 MHz <u>4/ 6/</u>	4, 5, 6	01		68		dB
				150.1 MHz <u>4/ 6/</u>				65		
30 MHz <u>4/ 6/</u>	4,5			02, 03	71.5					
	6				70					
70 MHz <u>4/ 6/</u>	4,5				71					
	6				69.5					
Spurious free dynamic range (SFDR) at -1 dBFS	SFDR			70.1 MHz <u>4/ 6/</u>	4, 5, 6	01	76		dBc	
				150.1 MHz <u>4/ 6/</u>			67			
Worst case second or third harmonic at -1 dBFS	2nd or 3rd	30 MHz <u>4/ 6/</u>	4	02, 03	82		dB			
			5		80					
			6		79					
		70 MHz <u>4/ 6/</u>	4		82					
			5		80					
			6		79					
Worst case fourth or higher harmonic at -1 dBFS	4 th plus	30 MHz <u>4/ 6/</u>	4,5	02, 03	84		dB			
			6		80					
		70 MHz <u>4/ 6/</u>	4,5		84					
			6		80					

See footnotes at end of table.

STANDARD MICROCIRCUIT DRAWING DLA LAND AND MARITIME COLUMBUS, OHIO 43218-3990	SIZE A		5962-04230
		REVISION LEVEL D	SHEET 7

TABLE IA. Electrical performance characteristics - continued.

Test	Symbol	Conditions <u>1/ 2/ 3/</u> AV _{CC} = 5 V, DV _{CC} = 3.3 V, f _c = 80 MSPS unless otherwise specified	Group A subgroups	Device type	Limits		Unit
					Min	Max	
Two tone intermodulation distortion (IMD) rejection	IMDR	At -7 dBFS, F1, F2 <u>4/ 6/ 7/</u>	4, 5, 6	01	75.5		dBc
ENCODE pulse width HIGH	t _{ENCH}	<u>4/ 5/ 8/</u>	9, 10, 11	All	5.625		ns
ENCODE pulse width LOW	t _{ENCL}	<u>4/ 5/ 8/</u>	9, 10, 11	All	5.625		ns
Encode rising to dataready falling	t _{DR}	<u>4/ 5/</u>	9, 10, 11	All	1.0	3.1	ns
Encode rising to dataready rising	t _{E_DR}	50% duty cycle <u>4/ 5/</u>	9, 10, 11	All	7.3	9.4	ns
ENCODE to DATA falling low	t _{E_FL}	<u>4/ 5/</u>	9, 10, 11	All	2.4	7.0	ns
ENCODE to DATA rising low	t _{E_RL}	<u>4/ 5/</u>	9, 10, 11	All	1.4	4.7	ns
ENCODE to DATA delay (hold time)	t _{H_E}	<u>4/ 5/</u>	9, 10, 11	All	1.4	4.7	ns
ENCODE to DATA delay (setup time)	t _{S_E}	<u>4/ 5/</u>	9, 10, 11	All	t _{ENC-} t _{E_FL(MAX)}	t _{ENC-} t _{E_FL(MIN)}	ns
		50% duty cycle <u>4/ 5/</u>			5.3	10.0	
Dataready to DATA delay (hold time)	t _{H_DR}	50% duty cycle <u>4/ 5/ 9/</u>	9, 10, 11	All	6.6	7.9	ns
Dataready to DATA delay (setup time)	t _{S_DR}	50% duty cycle <u>4/ 5/ 9/</u>	9, 10, 11	All	2.1	5.1	ns

1/ For device type 01; -35°C ≤ T_C ≤ +85°C. For device types 02 and 03; -55°C ≤ T_A ≤ +125°C.

2/ Device type 02 supplied to this drawing has been characterized through all levels M, D, P, L, R of irradiation. Device type 03 supplied to this drawing has been characterized through all levels M, D, P, L of irradiation. However, device type 02 is only tested at the "R" level and device type 03 is only tested at the "L" level. Pre and Post irradiation values are identical unless otherwise specified in Table I. When performing post irradiation electrical measurements for any RHA level, T_A = +25°C.

3/ For device type 02, this part may be dose rate sensitive in a space environment and may demonstrate enhanced low dose rate effects. Radiation end point limits for the noted parameters are guaranteed only for the conditions specified in MIL-STD-883, method 1019, condition A for device type 02 and condition D for device type 03. Device type 03, has been tested at low dose rate.

4/ Not tested post irradiation.

STANDARD MICROCIRCUIT DRAWING DLA LAND AND MARITIME COLUMBUS, OHIO 43218-3990	SIZE A		5962-04230
		REVISION LEVEL D	SHEET 8

TABLE IA. Electrical performance characteristics - continued.

- 5/ Parameter tested as part of device initial characterization and after design and process changes.
- 6/ All AC parameters tested by driving ENCODE and $\overline{\text{ENCODE}}$ differentially.
- 7/ F1 = 70.1 MHz, F2 = 72.1 MHz.
- 8/ Parameter is a function of t_{ENCL} and t_{ENCH} .
- 9/ Data ready to DATA delay ($t_{\text{H_DR}}$ and $t_{\text{S_DR}}$) is dependent on t_{ENC} and duty cycle.

TABLE IB. SEP test limits. 1/

Device types	SEP	Temperature	Bias V_S	Linear energy transfer (LET)
02 and 03	No SEL	+125°C	+5.25 V and 3.6 V	Effective LET $\leq 80 \text{ MeV-cm}^2/\text{mg}$

1/ For single event phenomenon (SEP) test conditions, see 4.4.4.2 herein.

STANDARD MICROCIRCUIT DRAWING DLA LAND AND MARITIME COLUMBUS, OHIO 43218-3990	SIZE A		5962-04230
		REVISION LEVEL D	SHEET 9

Case outline X

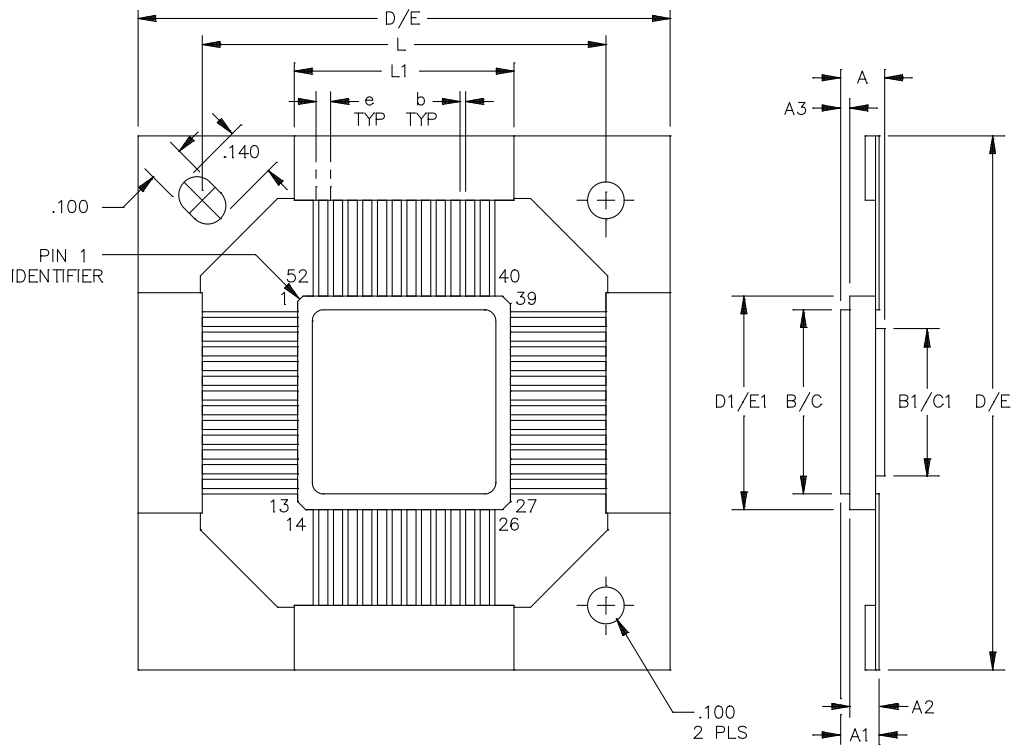

Symbol	Inches		Millimeters	
	Min	Max	Min	Max
A	.099	.131	2.155	3.327
A1	.090	.120	2.286	3.048
A2	.063	.077	1.600	1.956
A3	.019	.031	0.483	0.787
b	0.015 BSC		0.381 BSC	
B / C	.495	.505	12.573	12.827
B1 / C1	.395	.405	10.033	10.287
D / E	1.440	1.460	36.576	37.084
D1 / E1	.575	.585	14.605	14.859
e	.040 BSC		1.016 BSC	
L	1.090	1.110	27.686	28.194
L1	.590	.610	14.986	15.494

NOTES:

1. The U.S. Government preferred system of measurement is the metric S.I. system. However, since this item was originally designed using inch-pound units of measurements, in the event of conflict between the metric and inch-pound units, the inch-pound units shall take precedence.
2. Dimensions B1/C1 identify the exposed heat sink.

FIGURE 1. Case outline.

STANDARD MICROCIRCUIT DRAWING DLA LAND AND MARITIME COLUMBUS, OHIO 43218-3990	SIZE A		5962-04230
		REVISION LEVEL D	SHEET 10

Device types	All
Case outline	X
Terminal number	Terminal symbol
1	DVCC
2	GND
3	VREF
4	GND
5	ENC
6	$\overline{\text{ENC}}$
7	GND
8	AVCC
9	AVCC
10	GND
11	AIN
12	$\overline{\text{AIN}}$
13	GND
14	AVCC
15	GND
16	AVCC
17	GND
18	AVCC
19	GND
20	C1
21	GND
22	AVCC
23	GND
24	C2
25	GND
26	AVCC

Device types	All
Case outline	X
Terminal number	Terminal symbol
27	GND
28	AVCC
29	GND
30	AVCC
31	Do not connect
32	Do not connect
33	DVCC
34	GND
35	DMID
36	D0 (LSB)
37	D1
38	D2
39	D3
40	D4
41	D5
42	GND
43	DVCC
44	D6
45	D7
46	D8
47	D9
48	D10
49	D11
50	D12
51	D13 (MSB)
52	DRY

Note: It is required that the exposed paddle be soldered to GND plane to achieve the best electrical and thermal performance. Lid is internally tied to GND via package.

FIGURE 2. Terminal connections.

STANDARD MICROCIRCUIT DRAWING DLA LAND AND MARITIME COLUMBUS, OHIO 43218-3990	SIZE A		5962-04230
		REVISION LEVEL D	SHEET 11

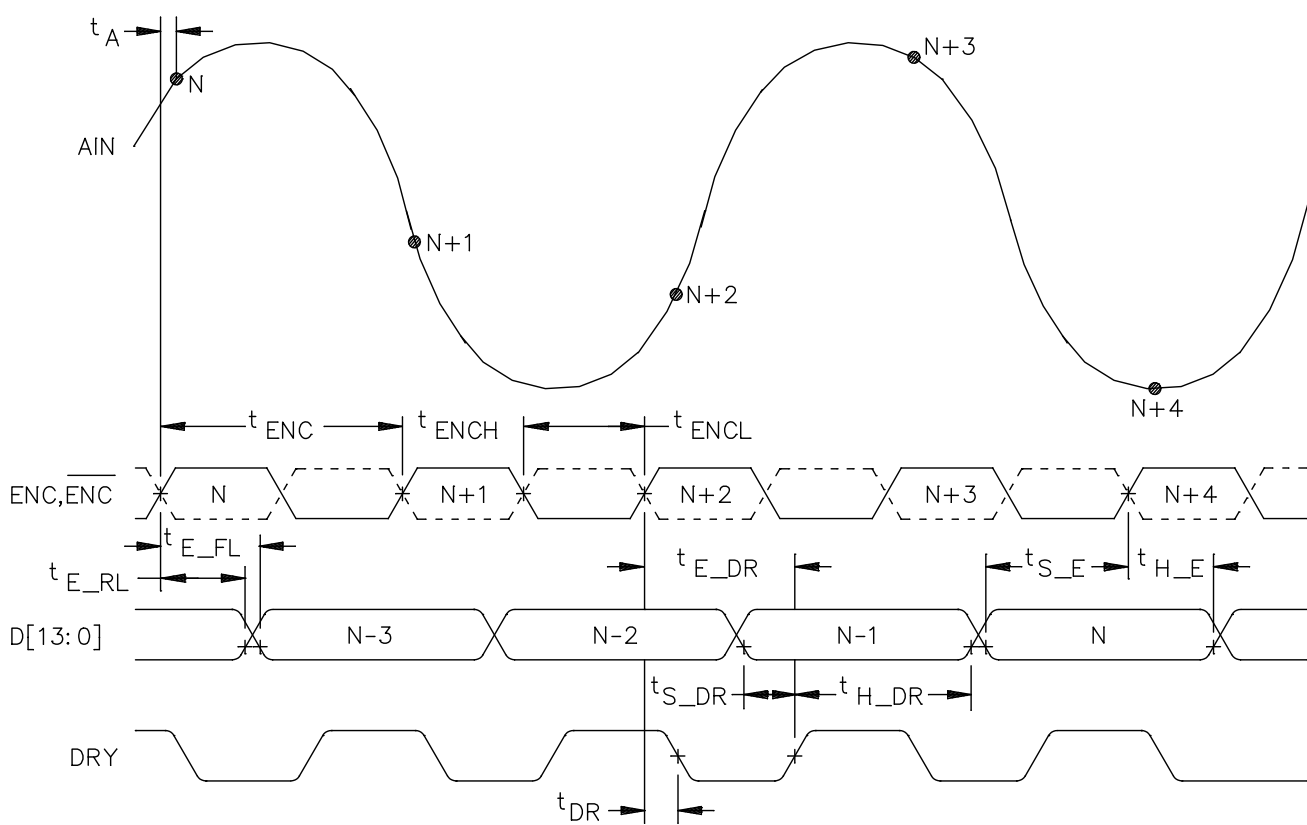

NOTE: Normally, $t_A = -500$ ps.

FIGURE 3. Timing waveforms.

STANDARD MICROCIRCUIT DRAWING DLA LAND AND MARITIME COLUMBUS, OHIO 43218-3990	SIZE A		5962-04230
		REVISION LEVEL D	SHEET 12

4. VERIFICATION

4.1 Sampling and inspection. For device classes Q and V, sampling and inspection procedures shall be in accordance with MIL-PRF-38535 or as modified in the device manufacturer's Quality Management (QM) plan. The modification in the QM plan shall not affect the form, fit, or function as described herein.

4.2 Screening. For device classes Q and V, screening shall be in accordance with MIL-PRF-38535, and shall be conducted on all devices prior to qualification and technology conformance inspection.

4.2.1 Additional criteria for device classes Q and V.

- a. The burn-in test duration, test condition and test temperature, or approved alternatives shall be as specified in the device manufacturer's QM plan in accordance with MIL-PRF-38535. The burn-in test circuit shall be maintained under document revision level control of the device manufacturer's Technology Review Board (TRB) in accordance with MIL-PRF-38535 and shall be made available to the acquiring or preparing activity upon request. The test circuit shall specify the inputs, outputs, biases, and power dissipation, as applicable, in accordance with the intent specified in method 1015 of MIL-STD-883.
- b. Interim and final electrical test parameters shall be as specified in table IIA herein.
- c. Additional screening for device class V beyond the requirements of device class Q shall be as specified in MIL-PRF-38535, appendix B.

4.3 Qualification inspection for device classes Q and V. Qualification inspection for device classes Q and V shall be in accordance with MIL-PRF-38535. Inspections to be performed shall be those specified in MIL-PRF-38535 and herein for groups A, B, C, D, and E inspections (see 4.4.1 through 4.4.4).

4.4 Conformance inspection. Technology conformance inspection for classes Q and V shall be in accordance with MIL-PRF-38535 including groups A, B, C, D, and E inspections, and as specified herein.

4.4.1 Group A inspection.

- a. Tests shall be as specified in table IIA herein.
- b. Subgroups 7 and 8 in table I, method 5005 of MIL-STD-883 shall be omitted.

4.4.2 Group C inspection. The group C inspection end-point electrical parameters shall be as specified in table IIA herein.

4.4.2.1 Additional criteria for device classes Q and V. The steady-state life test duration, test condition and test temperature, or approved alternatives shall be as specified in the device manufacturer's QM plan in accordance with MIL-PRF-38535. The test circuit shall be maintained under document revision level control by the device manufacturer's TRB in accordance with MIL-PRF-38535 and shall be made available to the acquiring or preparing activity upon request. The test circuit shall specify the inputs, outputs, biases, and power dissipation, as applicable, in accordance with the intent specified in method 1005 of MIL-STD-883.

4.4.3 Group D inspection. The group D inspection end-point electrical parameters shall be as specified in table IIA herein.

STANDARD MICROCIRCUIT DRAWING DLA LAND AND MARITIME COLUMBUS, OHIO 43218-3990	SIZE A		5962-04230
		REVISION LEVEL D	SHEET 13

TABLE IIA. Electrical test requirements.

Test requirements	Subgroups (in accordance with MIL-PRF-38535, table III)	
	Device class Q	Device class V
Interim electrical parameters (see 4.2)	1	1
Final electrical parameters (see 4.2)	1,2,3,4,5,6, <u>1/</u> 9,10,11	1,2,3,4,5,6, <u>1/ 2/</u> 9,10,11
Group A test requirements (see 4.4)	1,2,3,4,5,6,9, 10,11	1,2,3,4,5,6,9,10,11
Group C end-point electrical parameters (see 4.4)	1	1 <u>2/</u>
Group D end-point electrical parameters (see 4.4)	1	1
Group E end-point electrical parameters (see 4.4)	1,4	1,4

1/ PDA applies to subgroup 1.

2/ Delta limits as specified in table IIB shall be computed with reference to the previous interim electrical parameters. Delta parameters are excluded from PDA.

TABLE IIB. 240 hour burn-in and group C end-point electrical parameters. T_A = +25°C.

Parameter	Device type	240 hour delta limits	Group C Delta limits	Units
I _{AVCC}	02, 03	±6	±6	mA
I _{DVCC}	02, 03	±2	±2	mA
O _E	02, 03	±4	±4	mV

**STANDARD
MICROCIRCUIT DRAWING**
DLA LAND AND MARITIME
COLUMBUS, OHIO 43218-3990

SIZE
A

REVISION LEVEL
D

5962-04230

SHEET

14

4.4.4 Group E inspection. Group E inspection is required only for parts intended to be marked as radiation hardness assured (see 3.5 herein).

- a. End-point electrical parameters shall be as specified in table IIA herein.
- b. For device classes Q and V, the devices or test vehicle shall be subjected to radiation hardness assured tests as specified in MIL-PRF-38535 for the RHA level being tested. All device classes must meet the postirradiation end-point electrical parameter limits as defined in table IA at $T_A = +25^{\circ}\text{C} \pm 5^{\circ}\text{C}$, after exposure, to the subgroups specified in table IIA herein.

4.4.4.1 Total dose irradiation testing. Total dose irradiation testing shall be performed in accordance with MIL-STD-883 method 1019, condition A for device type 01, condition D for device type 02, and as specified herein.

4.4.4.2 Single event phenomena (SEP). When specified in the purchase order or contract, SEP testing shall be performed on class V devices. SEP testing shall be performed on the Standard Evaluation Circuit (SEC) or alternate SEP test vehicle as approved by the qualifying activity at initial qualification and after any design or process changes which may affect the upset or latchup characteristics. Test four devices with zero failures. ASTM F1192 may be used as a guideline when performing SEP testing. The test conditions for SEP are as follows:

- a. The ion beam angle of incidence shall be between normal to the die surface and 60° to the normal, inclusive (i.e. $0^{\circ} \leq \text{angle} \leq 60^{\circ}$). No shadowing of the ion beam due to fixturing or package related effects is allowed.
- b. The fluence shall be $\geq 10^7$ ions/cm².
- c. The flux shall be between 10^2 and 10^5 ions/cm²/s.
- d. The particle range shall be ≥ 20 microns in silicon.
- e. The test temperature shall be $+125^{\circ}\text{C}$ and the maximum rated operating temperature $\pm 10^{\circ}\text{C}$ for single event latchup testing.
- f. Bias conditions shall be $V_{CC} = 5.25$ V and $V_{CC} = 3.6$ V for latchup measurements.
- g. For SEP test limits, see Table IB herein.

5. PACKAGING

5.1 Packaging requirements. The requirements for packaging shall be in accordance with MIL-PRF-38535 for device classes Q and V.

6. NOTES

6.1 Intended use. Microcircuits conforming to this drawing are intended for use for Government microcircuit applications (original equipment), design applications, and logistics purposes.

6.1.1 Replaceability. Microcircuits covered by this drawing will replace the same generic device covered by a contractor prepared specification or drawing.

6.2 Configuration control of SMD's. All proposed changes to existing SMD's will be coordinated with the users of record for the individual documents. This coordination will be accomplished using DD Form 1692, Engineering Change Proposal.

6.3 Record of users. Military and industrial users should inform DLA Land and Maritime when a system application requires configuration control and which SMD's are applicable to that system. DLA Land and Maritime will maintain a record of users and this list will be used for coordination and distribution of changes to the drawings. Users of drawings covering microelectronic devices (FSC 5962) should contact DLA Land and Maritime-VA, telephone (614) 692-8108.

STANDARD MICROCIRCUIT DRAWING DLA LAND AND MARITIME COLUMBUS, OHIO 43218-3990	SIZE A		5962-04230
		REVISION LEVEL D	SHEET 15

6.4 Comments. Comments on this drawing should be directed to DLA Land and Maritime-VA, Columbus, Ohio 43218-3990, or telephone (614) 692-0540.

6.5 Abbreviations, symbols, and definitions. The abbreviations, symbols, and definitions used herein are defined in MIL-PRF-38535 and MIL-HDBK-1331.

6.6 Sources of supply.

6.6.1 Sources of supply for device classes Q and V. Sources of supply for device classes Q and V are listed in MIL-HDBK-103 and QML-38535. The vendors listed in MIL-HDBK-103 and QML-38535 have submitted a certificate of compliance (see 3.6 herein) to DLA Land and Maritime-VA and have agreed to this drawing.

6.7 Additional information. When applicable, a copy of the following additional data shall be maintained and available from the device manufacturer:

- a. RHA test conditions (SEP).
- b. Occurrence of latchup (SEL).

STANDARD MICROCIRCUIT DRAWING DLA LAND AND MARITIME COLUMBUS, OHIO 43218-3990	SIZE A		5962-04230
		REVISION LEVEL D	SHEET 16

STANDARD MICROCIRCUIT DRAWING BULLETIN

DATE: 15-12-10

Approved sources of supply for SMD 5962-04230 are listed below for immediate acquisition information only and shall be added to MIL-HDBK-103 and QML-38535 during the next revision. MIL-HDBK-103 and QML-38535 will be revised to include the addition or deletion of sources. The vendors listed below have agreed to this drawing and a certificate of compliance has been submitted to and accepted by DLA Land and Maritime-VA. This information bulletin is superseded by the next dated revision of MIL-HDBK-103 and QML-38535. DLA Land and Maritime maintains an online database of all current sources of supply at <http://www.landandmaritime.dla.mil/Programs/Smcr/>.

Standard microcircuit drawing PIN <u>1/</u>	Vendor CAGE number	Vendor similar PIN <u>2/</u>
5962-0423001QXC	24355	AD6645ASQ/QMLQ
5962R0423002VXC	24355	AD6645ASQ/QMLR
5962L0423003VXC	24355	AD6645ASQ/QMLL

- 1/ The lead finish shown for each PIN representing a hermetic package is the most readily available from the manufacturer listed for that part. If the desired lead finish is not listed contact the vendor to determine its availability.
- 2/ Caution. Do not use this number for item acquisition. Items acquired to this number may not satisfy the performance requirements of this drawing.

Vendor CAGE number

24355

Vendor name and address

Analog Devices
 Route 1 Industrial Park
 P.O. Box 9106
 Norwood, MA 02062
 Point of contact: 7910 Triad Center Drive
 Greensboro, NC 27409-9605

The information contained herein is disseminated for convenience only and the Government assumes no liability whatsoever for any inaccuracies in the information bulletin.