

REVISIONS			
LTR	DESCRIPTION	DATE (YR-MO-DA)	APPROVED
A	Revise to present DoD policy requirements; remove source of supply. Editorial corrections throughout.	00-07-27	K. Cottongim
B	Add pure tin prohibition paragraph. Editorial changes throughout.	07-02-14	M. Radecki
C	QR Code added. Editorial changes throughout.	16-06-06	M. Radecki
D	5 year review and editorial changes throughout.	24-10-01	M. Radecki

CURRENT DESIGN ACTIVITY CAGE CODE 037Z3
 DEFENSE LOGISTICS AGENCY
 DEFENSE SUPPLY CENTER, COLUMBUS
 COLUMBUS, OHIO 43218-3990

PREVIOUS CAGE CODE 14933
 SUPERSEDED BY 037Z3.



Prepared in accordance with ASME Y14.24

Selected Item Drawing

Revision Status of Sheets												
REV												
SHEET												
REV	D	D	D	D	D	D	D	D				
SHEET	1	2	3	4	5	6	7	8				

PMIC N/A Original date of drawing 1989-08-17	PREPARED BY Alan R. Knox		DEFENSE ELECTRONIC SUPPLY CENTER DAYTON, OHIO 45444-5000	
	CHECKED BY David W. Withrow		TITLE RESISTOR-CAPACITOR NETWORK, 16-PIN DIP	
	APPROVED BY David E. Moore			
	SIZE A	CAGE CODE 14933	DWG NO. 89004	
	REV D		PAGE 1 OF 8	

1. SCOPE

1.1 Scope. This drawing describes the general requirements for a 16 pin, dual in-line package (DIP), resistor-capacitor network.

1.2 Part or Identifying Number (PIN). The complete PIN is as follows:

89004-M5100GK

89004- - Drawing number
M - Characteristic (3.3.1.3)
5100 - Resistance (3.3.1.1)
G - Resistance Tolerance (3.3.1.2)
K - Schematic (3.3.1.6)

2. APPLICABLE DOCUMENTS

2.1 Government documents.

2.1.1 Specifications, standards, and handbooks. The following specifications, standards, and handbooks form a part of this document to the extent specified herein. Unless otherwise specified, the issues of these documents are those cited in the solicitation or contract.

DEPARTMENT OF DEFENSE SPECIFICATIONS

[MIL-PRF-83401](#) - Resistor Network, Fixed, Film, and Capacitor-Resistor Network, Ceramic Capacitor and Fixed Film Resistor, General Specification for.

DEPARTMENT OF DEFENSE STANDARDS

[MIL-STD-202](#) - Test Methods Standard Electronic and Electrical Component Parts
[MIL-STD-202-301](#) - Method 301, Dielectric Withstanding Voltage
[MIL-STD-202-302](#) - Method 302, Insulation Resistance
[MIL-STD-202-305](#) - Method 305, Capacitance.
[MIL-STD-1285](#) - Marking of Electrical and Electronic Parts.

(Copies of these documents are available online at <https://quicksearch.dla.mil>).

2.2 Order of precedence. Unless otherwise noted herein or in the contract, in the event of a conflict between the text of this document and the references cited herein (except for related specification sheets), the text of this document takes precedence unless otherwise noted. Nothing in this document, however, supersedes applicable laws and regulations unless a specific exemption has been obtained.

3. REQUIREMENTS

3.1 Item Requirements. The individual item requirements shall be in accordance with [MIL-PRF-83401](#) and as specified herein.

3.2 Interface and physical dimensions. The resistor shall meet the interface and physical dimensions as specified in [MIL-PRF-83401](#) and herein (see [figure 1](#)).

3.3 Electrical characteristics.

3.3.1 Resistor requirements.

3.3.1.1 Resistance. Resistance values available shall be in accordance with [MIL-PRF-83401](#) and herein (see [table I](#)).

3.3.1.2 Resistance tolerance. Unless otherwise specified (see [table I](#)) resistors are available in resistance tolerances of ± 1 percent (F), ± 2 percent (G), and ± 5 percent (J).

3.3.1.3 Resistance temperature characteristics. The resistance temperature characteristics available shall be characteristic K and characteristic M in accordance with [MIL-PRF-83401](#) and herein (see [table I](#)).

3.3.1.4 Power rating. The power rating shall be 0.1 watt for each resistor. The total network power rating shall be 1.2 watts.

DEFENSE ELECTRONIC SUPPLY CENTER DAYTON, OHIO	SIZE A	CODE IDENT NO. 14933	DWG NO. 89004
		REV D	PAGE 2

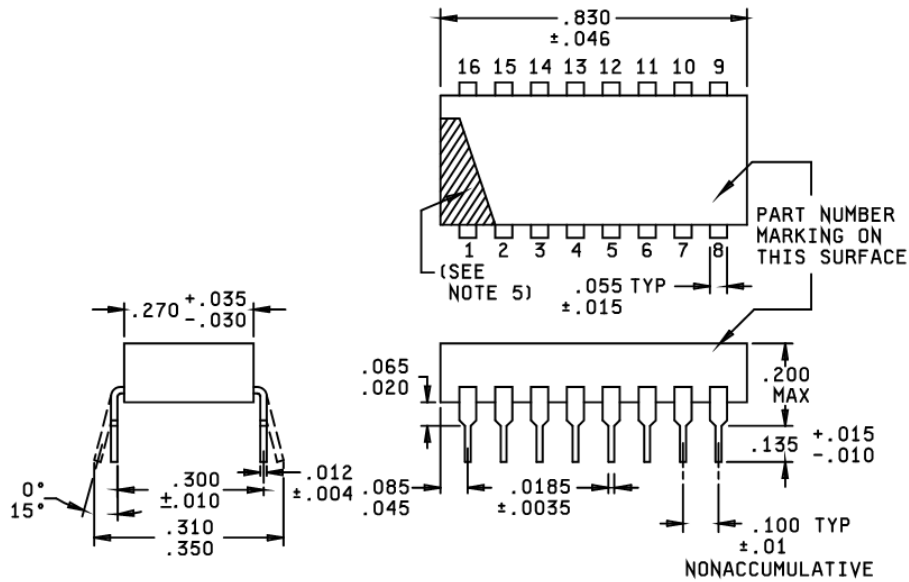

Inches	mm	Inches	mm	Inches	mm	Inches	mm	Inches	mm	Inches	mm
0.0035	0.089	0.015	0.38	0.065	1.65	0.045	1.14	0.200	5.08	0.350	8.89
0.004	0.10	0.0185	0.46	0.085	2.16	0.046	1.17	0.270	6.86	0.830	21.08
0.010	0.25	0.020	0.51	0.030	0.76	0.100	2.54	0.300	7.62		
0.012	0.30	0.055	1.40	0.035	0.89	0.135	3.43	0.310	7.87		

NOTES:

1. Dimensions are in inches.
2. Metric equivalents are given for general information only.
3. Unless otherwise specified, tolerance is ± 0.005 (0.13 mm).
4. The pictorial view of the style above is given as representative of the envelope of the item. Slight deviations from the outline shown, which are contained within the envelope, and do not alter the functional aspects of the devices are acceptable.
5. Pin 1 locator shall be a dot, notch, or numeral 1 adjacent to pin No. 1, in the shaded area.
6. Terminal centerline to centerline measurements made at point of emergence of the lead from the body.
7. Measurement made at point of emergence of the lead from the body.

FIGURE 1. Resistor network, 16-pin DIP.

TABLE I. Resistance and capacitive values.

PIN 89004-	Schematic	Resistance (ohms)		Capacitance (microfarads)
*5100*K <u>1/</u>	K	510		0.01
*49R9*M <u>1/</u>	M	49.9		
*68R0*M <u>1/</u>		68		
*75R0*M <u>1/</u>		75		
*1000*M <u>1/</u>		100		
*A001*N <u>1/</u>	N	<u>RS</u> 39 $\pm 5\%$	<u>RE</u> 500 $\pm 2\%$	

1/ Asterisks in the PIN shall be coded to represent resistance tolerances and resistance characteristic allowed herein (see 1.2, 3.3.1.2, and 3.3.1.3)

DEFENSE ELECTRONIC SUPPLY CENTER DAYTON, OHIO	SIZE A	CODE IDENT NO. 14933	DWG NO. 89004
		REV D	PAGE 3

3.3.1.5 Voltage rating. The maximum continuous working voltage for each resistor shall not exceed 100 volts dc or ac rms.

3.3.1.6 Schematic. The schematic of the resistor-capacitor network shall be identified by a single letter in accordance with MIL-PRF-83401 and herein (see figure 2).

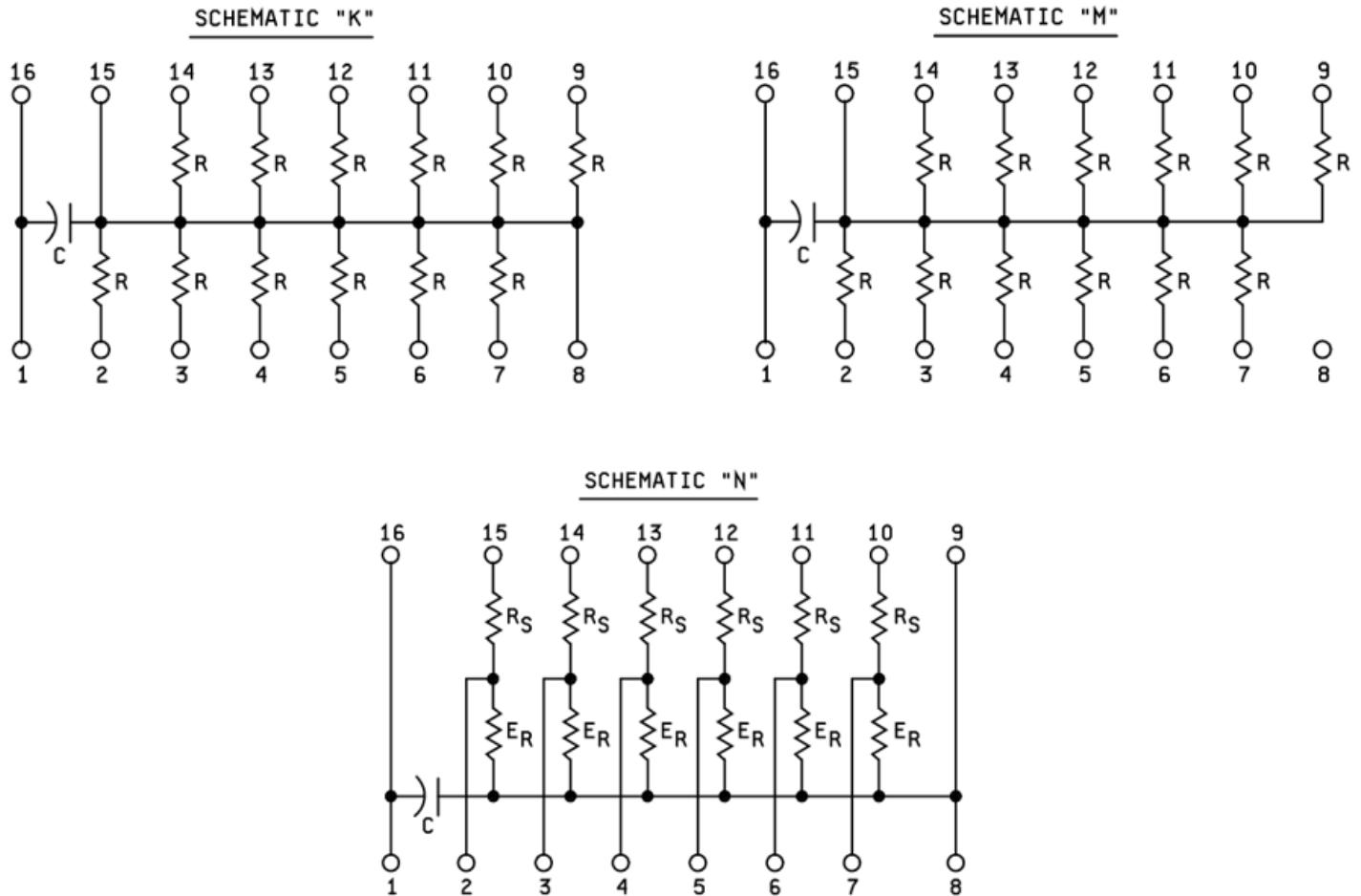

FIGURE 2. Schematics.

3.3.2 Capacitor requirements.

3.3.2.1 Capacitance. When tested as specified in 4.3, the capacitance value shall be 0.01 μ F, within tolerance.

3.3.2.2 Capacitance tolerance. Capacitors are available in capacitance tolerance of ± 20 percent (M).

3.3.2.3 Dissipation factor. When tested as specified in 4.3.1, the dissipation factor shall not exceed 2.5 percent.

3.3.2.4 Voltage rating. The voltage rating shall be 25 volts dc.

3.3.2.5 Dielectric withstanding voltage. When tested as specified in 4.3.2, there shall be no evidence of mechanical damage, arcing, or breakdown.

DEFENSE ELECTRONIC SUPPLY CENTER DAYTON, OHIO	SIZE A	CODE IDENT NO. 14933	DWG NO. 89004
		REV D	PAGE 4

3.3.2.6 Insulation resistance. When tested as specified in 4.3.3, the insulation resistance of the capacitor shall be not less than 100,000 megohms unless otherwise specified.

- a. Pre-assembly: The insulation resistance of the internal capacitor prior to assembly in the network shall be in accordance with the following requirements:
 - (1) 25°C - not less than 10,000 megohms or 100 megohm-microfarads, whichever is less.
 - (2) 125°C - not less than 5,000 megohms or 50 megohm-microfarads, whichever is less.
- b. Post assembly: The insulation resistance of the internal capacitor after assembly in the network shall be in accordance with the following requirements, when networks are tested in accordance with MIL-PRF-83401.
 - (1) 25°C - not less than 10,000 megohms or 100 megohm-microfarads, whichever is less.
 - (2) 125°C - not less than 5,000 megohms or 50 megohm-microfarads, whichever is less.

3.3.2.7 Capacitance-temperature characteristic. When tested as specified in 4.3.4, the capacitance change shall not exceed ±15 percent at -55°C and +125°C when tested with minimum voltage and +15 percent, -25 percent at -55°C and +125°C when tested at rated voltage.

3.4 Network requirements. When tested as specified in MIL-PRF-83401 and herein, and unless otherwise specified, the networks shall meet the respective requirements of MIL-PRF-83401 and the following:

- a. ΔC shall not exceed ±10 percent.
- b. DF shall not exceed 2.5 percent.

3.4.1 Thermal shock. When tested as specified in 4.4, networks shall meet the requirements of 3.4.

3.4.2 Power conditioning. When tested as specified in 4.5, networks shall meet the requirements of 3.4.

3.4.3 Network dielectric withstanding voltage. Networks shall be tested as specified and meet the requirements of MIL-PRF-83401.

3.4.4 Network insulation resistance. Networks shall be tested as specified and meet the requirements of MIL-PRF-83401.

3.4.5 Short-time overload. When tested as specified in 4.6, networks shall meet the requirements of 3.4.

3.4.6 Solderability. Networks shall be tested as specified and meet the requirements of MIL-PRF-83401.

3.4.7 Resistance to solvents. Networks shall be tested as specified and meet the requirements of MIL-PRF-83401.

3.5 Pure tin. The use of pure tin, as an underplate or final finish is prohibited both internally and externally. Tin content of resistor components and solder shall not exceed 97 percent, by mass. Tin shall be alloyed with a minimum of 3 percent lead, by mass (see 6.3).

3.6 Marking. Marking shall be in accordance with MIL-STD-1285 except the networks shall be marked with the PIN as specified herein (see 1.2), the manufacturer's name or Commercial and Government Entity (CAGE) code, and date lot codes.

3.7 Recycled, recovered, environmentally preferable, or biobased materials. Recycled, recovered, environmentally preferable, or biobased materials should be used to the maximum extent possible, provided that the material meets or exceeds the operational and maintenance requirements, and promotes economically advantageous life cycle costs.

3.8 Manufacturer eligibility. To be eligible for listing as an approved source of supply, a manufacturer shall be listed on the MIL-PRF-83401 Qualified Products List for at least one part, or perform the group A and group B inspections specified herein on a sample of parts agreed upon by the manufacturer and DLA Land and Maritime - VAT.

3.8.1 Certificate of compliance. A certificate of compliance shall be required from manufacturers requesting to be a approved source of supply.

3.9 Workmanship. Resistors shall be uniform in quality and free from defects that will affect life, serviceability, or appearance.

DEFENSE ELECTRONIC SUPPLY CENTER DAYTON, OHIO	SIZE	CODE IDENT NO.	DWG NO.
	A	14933	89004
		REV D	PAGE 5

4. VERIFICATION

4.1 Qualification inspection. Qualification inspection is not applicable to this document.

4.2 Conformance inspection.

4.2.1 Inspection of product for delivery. Inspection of product for delivery shall consist of group A and group B inspections specified in table II and table III herein.

TABLE II. Group A inspection.

Inspection	Requirement paragraph	Test method paragraph	Number of samples
<u>Subgroup 1</u>			
Thermal shock	3.4.1	4.4	100 percent inspection
Power conditioning	3.4.2	4.5	
Resistance	3.3.1.1	1/	
Capacitance	3.3.2.1	4.3	
Dissipation factor	3.3.2.3	4.3.1	
<u>Subgroup 2</u>			
Visual and mechanical Inspection	3.1, 3.2, 1/ 3.6, and 3.9	1/	13

1/ See MIL-PRF-83401.

TABLE III. Group B inspection.

Inspection	Requirement paragraph	Test method paragraph	Number of samples	Number of failures allowed
<u>Subgroup 1</u>				
Resistance temperature characteristic	3.3.1.3	1/	13	0
Capacitance temperature characteristic	3.3.2.7	4.3.4		
Dielectric withstanding voltage (network)	3.4.3	1/		
Dielectric withstanding voltage (capacitor)	3.3.2.5	4.3.2		
Insulation resistance (network)	3.4.4	1/		
Insulation resistance (capacitor)	3.3.2.6	4.3.3		
Short-time overload	3.4.5	4.6		
<u>Subgroup 2</u>				
Solderability	3.4.6	1/	6	
Resistance to solvents	3.4.7	1/	8	

1/ See MIL-PRF-83401.

4.2.2 Group A inspection. Group A inspection shall consist of the inspections specified in table II, and shall be made on the same set of sample units, in the order shown.

4.2.2.1 Subgroup 1 tests. Subgroup 1 tests shall be performed on a production lot basis on 100 percent of the product supplied under this drawing. Networks that are out of resistance or capacitance tolerance, or which experience a change in resistance or capacitance greater than that permitted for the tests of this subgroup shall be removed from the lot. Only lots having not more than three percent rejects or one network, whichever is greater due to exceeding the specified resistance/capacitance change limit, as a result of subgroup 1 tests shall be furnished on orders. Corrective action shall be taken on such units and new pieces furnished.

4.2.2.2 Subgroup 2 tests. Statistical sampling inspection shall be performed on an inspection lot basis. A sample of 13 parts shall then be randomly selected. If one or more defects are found, the lot shall be rescreened and defects removed. A new sample of 13 parts shall then be randomly selected. If one or more defects are found in this second sample, the lot shall be rejected and shall not be supplied to this drawing.

DEFENSE ELECTRONIC SUPPLY CENTER DAYTON, OHIO	SIZE A	CODE IDENT NO. 14933	DWG NO. 89004
		REV D	PAGE 6

4.2.3 Group B inspection. Group B inspection shall consist of the examinations and tests specified in [table III](#), in the order shown. They shall be performed on samples from lots which have been subjected to and passed the group A inspection.

4.2.3.1 Certification. The acquiring activity, at its discretion, may accept a certificate of compliance with group B requirements in lieu of performing group B tests (see [6.2d](#)).

4.2.3.2 Subgroup 1. A sample of 13 parts shall be randomly selected. If one or more defects are found, the lot shall be rescreened and defects removed. If one or more defects are found a new sample of 13 parts shall then be randomly selected. If one or more defects are found in the second sample, the lot shall be rejected and shall not be supplied to this drawing.

4.2.3.3 Subgroup 2. A sample consisting of 14 parts shall be randomly selected, 6 samples subjected to the solderability test and 8 parts to the resistance to solvents test. If one or more defects are found, the lot shall be rescreened and defects removed. A new sample of 14 parts shall then be randomly selected. If one or more defects are found in the second sample, the lot shall be rejected and shall not be supplied to this drawing.

4.3 Capacitance. Capacitors shall be tested in accordance with [method 305](#) of [MIL-STD-202](#). The following details and exceptions shall apply (see [3.3.2](#)):

- a. Test frequency: 1 kHz \pm 100 Hz.
- b. Test voltage: 1.0 volt \pm 0.2 volts rms.

4.3.1 Dissipation factor. The dissipation factor shall be measured with a capacitance bridge or other suitable method at a frequency of 1 kHz \pm 100 Hz and a voltage of 1.0 \pm 0.2 volts rms. The inherent accuracy of the measurement shall be \pm 2 percent of the reading +0.1 percent dissipation factor (absolute). (see [3.3.2.3](#))

4.3.2 Dielectric withstanding voltage (capacitor). The capacitor shall be tested in accordance with [method 301](#) of [MIL-STD-202](#). A voltage of 2.5 times the rated voltage shall be applied across the capacitor from 0 to maximum within 1 second with the surge current limited to 50 mA. The voltage shall be applied for 5 seconds \pm 1 second. (see [3.3.2.5](#)).

4.3.3 Insulation resistance of the capacitor. Capacitors shall be tested in accordance with [method 302](#) of [MIL-STD-202](#). Test voltage shall be 25 volts. (see [3.3.2.6](#)).

4.3.4 Capacitance-temperature characteristic. The temperature of each capacitor shall be varied as specified in [table IV](#). Capacitance measurements shall be made at the frequency and voltage specified in 4.3a and 4.3b. The dc rated voltage specified in [table IV](#) shall be maintained on the capacitor during steps F to G inclusive. Capacitance measurement shall be made at each step specified in [table IV](#) and at a sufficient number of intermediate temperatures, between steps B and G to establish a true characteristic curve. Capacitors shall be kept at each temperature until temperature equilibrium is attained. (see [3.3.2.7](#))

4.4 Thermal shock. The thermal shock test shall be as specified in [MIL-PRF-83401](#) except that following dc resistance measurements, capacitance and dissipation factor shall be measured as specified in 4.3 and 4.3.1. (see [3.4.1](#)).

Table IV. Voltage-temperature limit cycle.

Step	Voltage, dc	Temperature (°C)
A	None	+25 \pm 2
B	None	-55 \pm 2
C ^{1/}	None	+25 \pm 2
D	None	+125 \pm 2
E	Rated	+125 \pm 2
F	Rated	+25 \pm 2
G	Rated	-55 \pm 2

^{1/} Reference point.

4.5 Power conditioning. Networks shall be tested in accordance with [MIL-PRF-83401](#). The following details and exceptions shall apply (see [3.4.2](#)):

- a. Initial measurements: In addition to dc resistance, capacitance and dissipation factor shall be measured as specified in [4.3](#) and [4.3.1](#).
- b. Operating conditions: In addition to the conditions specified, the voltage applied to the capacitor shall be 50 volts dc.

DEFENSE ELECTRONIC SUPPLY CENTER DAYTON, OHIO	SIZE A	CODE IDENT NO. 14933	DWG NO. 89004
		REV D	PAGE 7

4.6 Short-time overload. Networks shall be tested in accordance with MIL-PRF-83401 except that following dc resistance, capacitance and dissipation factor shall be measured as specified in 4.3 and 4.3.1. (see 3.4.5).

5. PACKAGING

5.1 Packaging. For acquisition purposes, the packaging requirements shall be as specified in the contract or order (see 6.2). When packaging of materiel is to be performed by DoD or in-house contractor personnel, these personnel need to contact the responsible packaging activity to ascertain packaging requirements. Packaging requirements are maintained by the Inventory Control Point's packaging activities within the Military Service or Defense Agency, or within the military service's system commands. Packaging data retrieval is available from the managing Military Department's or Defense Agency's automated packaging files, CD-ROM products, or by contacting the responsible packaging activity.

6. NOTES

(This section contains information of a general or explanatory nature that may be helpful, but is not mandatory.)

6.1 Intended use. Resistor networks described herein are intended for use in circuits where microcircuitry is intended.

6.2 Ordering data. The contract or purchase order should specify the following:

- a. Complete DLA land and Maritime CAGE CODE (037Z3) and PIN (see 1.2).
- b. Requirements for delivery: One copy of the conformance inspection data or certification of compliance that parts have passed conformance inspection with each shipment of parts by the manufacturer.
- c. Requirements for packaging and packing. (i.e. ESD sensitive packaging).
- d. Whether the manufacturer performs the group B tests or provides certification of compliance with group B requirements.

6.3 Tin whisker growth. The use of alloys with tin content greater than 97 percent, by mass, may exhibit tin whisker growth problems after manufacture. Tin whiskers may occur anytime from a day to years after manufacture and can develop under typical operating conditions, on products that use such materials. Conformal coatings applied over top of a whisker-prone surface will not prevent the formation of tin whiskers. Alloys of 3 percent lead, by mass, have shown to inhibit the growth of tin whiskers. For additional information on this matter, refer to ASTM-B545 (Standard Specification for Electrodeposited Coatings of Tin).

6.4 User of record. Coordination of this document for future revisions is coordinated only with the approved source of supply and the users of record of this document. Requests to be added as a recorded user of this drawing may be achieved online at resistor@dla.mil or in writing to: DLA Land and Maritime-VAT, Post Office Box 3990, Columbus, OH 43218-3990 or by telephone (614) 692-4546 or DSN 850-4546.

6.5 Approved source of supply. Approved source of supply is listed herein. Additional sources will be added as they become available. Assistance in the use of this drawing may be obtained online at resistor@dla.mil or contact DLA Land and Maritime-VAT, Post Office Box 3990, Columbus, OH 43218-3990 or by telephone (614) 692-4546 or DSN 850-4546

DLA Land and Maritime drawing PIN	Vendors similar designation or type number <u>1/</u>	Vendor CAGE	Vendor's name and address
89004-***** <u>2/</u>	MDRC1600	91637	Vishay Dale P.O. Box 609, 1122 23rd St., Columbus, NE 68602-0609 http://www.vishay.com/

1/ Parts must be purchased to the DLA Land and Maritime CAGE CODE (037Z3) and PIN to assure that all performance and test requirements are met.

2/ Char K and M; all resistance values for schematics K, M, and N; all resistance tolerances

DEFENSE ELECTRONIC SUPPLY CENTER DAYTON, OHIO	SIZE A	CODE IDENT NO. 14933	DWG NO. 89004
		REV D	PAGE 8