

REVISIONS			
LTR	DESCRIPTION	DATE (YR-MO-DA)	APPROVED
A	Changes in accordance with NOR 5905-R006-93	93-05-28	D. Moore
B	Update and validation of drawing. Editorial changes throughout.	00-07-11	K. Cottongim
C	Add pure tin prohibition paragraph. Editorial changes throughout.	07-02-07	M. Radecki
D	QR Code added. Schematic 01, 02, 06 and 07 RTC change. Vendor address change Editorial changes throughout.	16-06-06	M. Radecki
E	5 year review and editorial changes throughout.	24-10-01	M. Radecki

CURRENT DESIGN ACTIVITY CAGE CODE 037Z3
 DEFENSE LOGISTICS AGENCY
 DEFENSE SUPPLY CENTER, COLUMBUS
 COLUMBUS, OHIO 43218-3990

PREVIOUS CAGE CODE 14933
 SUPERSEDED BY 037Z3.



Prepared in accordance with ASME Y14.24

Selected Item Drawing

Revision Status of Sheets

REV																				
SHEET																				
REV	E	E	E	E	E	E	E	E	E	E	E	E								
SHEET	1	2	3	4	5	6	7	8	9	10	11	12								

PMIC N/A Original date of drawing 1988-02-03	PREPARED BY Alan R. Knox				DEFENSE ELECTRONIC SUPPLY CENTER DAYTON, OHIO 45444-5000															
	CHECKED BY David W. Withrow				TITLE RESISTOR NETWORK, 9-PIN SIP, MULTIPLE VALUES, MULTIPLE TOLERANCES, LOW PROFILE															
	APPROVED BY David E. Moore																			
	SIZE A		CAGE CODE 14933		DWG NO. 87103															
	REV E				PAGE 1 OF 12															

1. SCOPE

1.1 Scope. This drawing describes the requirements for a 9 pin single in line package (SIP).

1.2 Part or Identifying Number (PIN). The complete PIN is as follows:

87103-01

87103- - Drawing number
01 - Schematic number (see [figure 2](#))

2. APPLICABLE DOCUMENTS

2.1 Government documents.

2.1.1 Specifications, standards, and handbooks. The following specifications, standards, and handbooks form a part of this document to the extent specified herein. Unless otherwise specified, the issues of these documents are those cited in the solicitation or contract.

DEPARTMENT OF DEFENSE SPECIFICATIONS

[MIL-PRF-83401](#) - Resistor Network, Fixed, Film, and Capacitor-Resistor Network, Ceramic Capacitor and Fixed Film Resistor, General Specification for.

DEPARTMENT OF DEFENSE STANDARDS

[MIL-STD-1285](#) - Marking of Electrical and Electronic Parts.

(Copies of these documents are available online at <https://quicksearch.dla.mil>).

2.2 Order of precedence. Unless otherwise noted herein or in the contract, in the event of a conflict between the text of this document and the references cited herein (except for related specification sheets), the text of this document takes precedence unless otherwise noted. Nothing in this document, however, supersedes applicable laws and regulations unless a specific exemption has been obtained.

3. REQUIREMENTS

3.1 Item Requirements. The individual item requirements shall be in accordance with [MIL-PRF-83401](#) and as specified herein.

3.2 Interface and physical dimensions. The resistor shall meet the interface and physical dimensions as specified in [MIL-PRF-83401](#) and herein (see [figure 1](#)).

3.3 Electrical characteristics.

3.3.1 Power rating. Unless otherwise specified, each individual resistance element shall have a maximum power rating of 125 milliwatts (mW) at 70°C. All individual resistance elements are derated linearly to zero power at 150°C. The total power dissipated by the package shall not exceed the sum of the individual resistance element power rating in the network.

3.3.2 Voltage rating. Each resistor element shall have a maximum voltage rating of 100 V dc or ac rms.

3.3.3 Resistance temperature coefficient. Unless otherwise specified, the resistance temperature coefficient shall be ± 100 ppm/°C.

3.3.4 Resistance. The resistance values shall be in accordance with [figure 2](#).

3.3.5 Resistance tolerance. The resistance tolerance shall be in accordance with [figure 2](#).

3.3.6 Schematics. Resistor networks are available in schematics listed on [figure 2](#).

3.4 Characteristic. The characteristic shall be in accordance with [MIL-PRF-83401](#), characteristic K.

3.5 Environmental requirements. The environmental requirements shall be in accordance with [MIL-PRF-83401](#), characteristic K.

3.6 Marking. Marking shall be in accordance with [MIL-STD-1285](#) except the networks shall be marked with the PIN as specified herein (see [1.2](#)), the manufacturer's name or Commercial and Government Entity (CAGE) code, and date lot codes.

DEFENSE ELECTRONIC SUPPLY CENTER DAYTON, OHIO	SIZE A	CODE IDENT NO. 14933	DWG NO. 87103
		REV E	PAGE 2

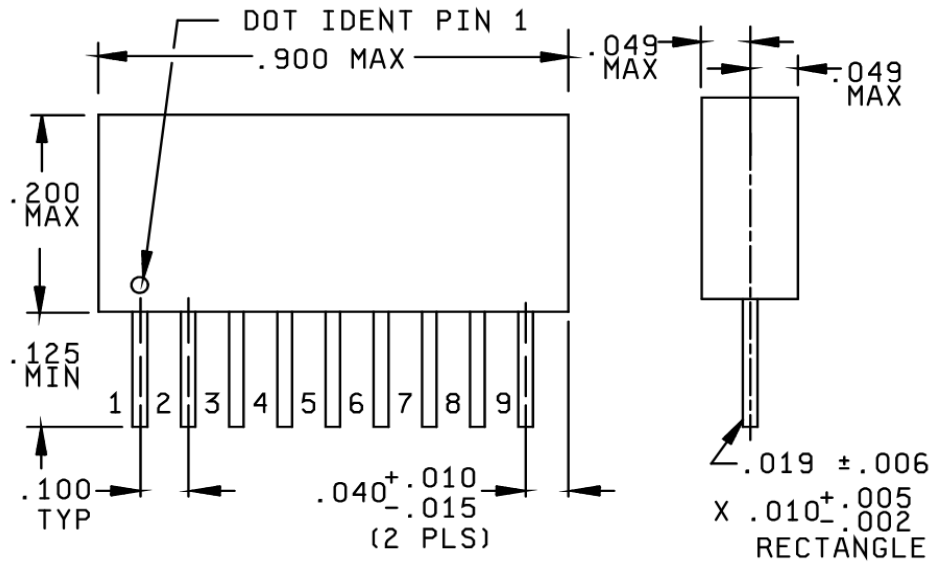

Inches	mm	Inches	mm	Inches	mm	Inches	mm	Inches	mm	Inches	mm
0.002	0.05	0.006	0.15	0.015	0.38	0.040	1.01	0.100	2.54	0.200	5.08
0.005	0.12	0.010	0.25	0.019	0.48	0.049	1.24	0.125	3.17	0.900	22.86

NOTES:

1. All dimensions are in inches.
2. Metric equivalents are given for general information.
3. Unless otherwise specified, dimensional tolerance shall be ± 0.02 (0.5 mm) for two place decimals and ± 0.010 (0.25 mm) for three place decimals.

FIGURE 1. Resistor network 9-pin SIP.

Schematic 01

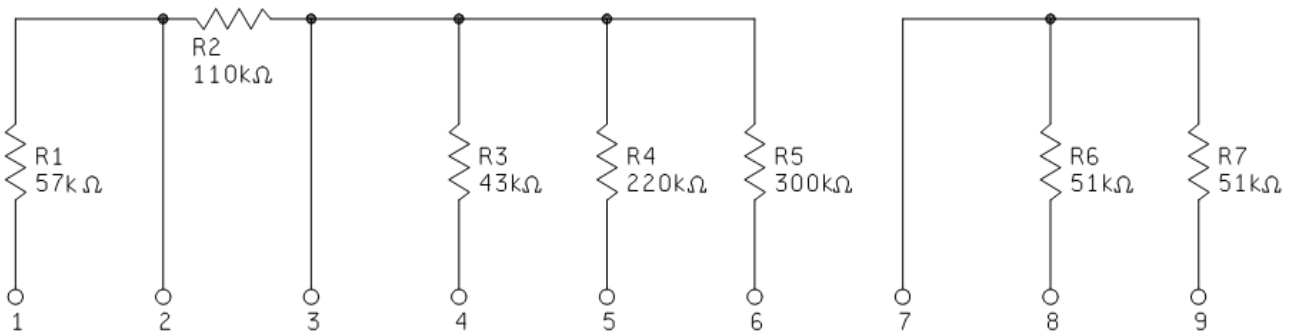

NOTES:

1. Resistor tolerance shall be ± 2 percent.
2. Resistance values are in kilohms.
3. Resistor temperature coefficient shall be ± 100 ppm/ $^{\circ}$ C.

FIGURE 2. Schematic, resistance, and tolerance.

DEFENSE ELECTRONIC SUPPLY CENTER DAYTON, OHIO	SIZE A	CODE IDENT NO. 14933	DWG NO. 87103
		REV E	PAGE 3

Schematic 02.

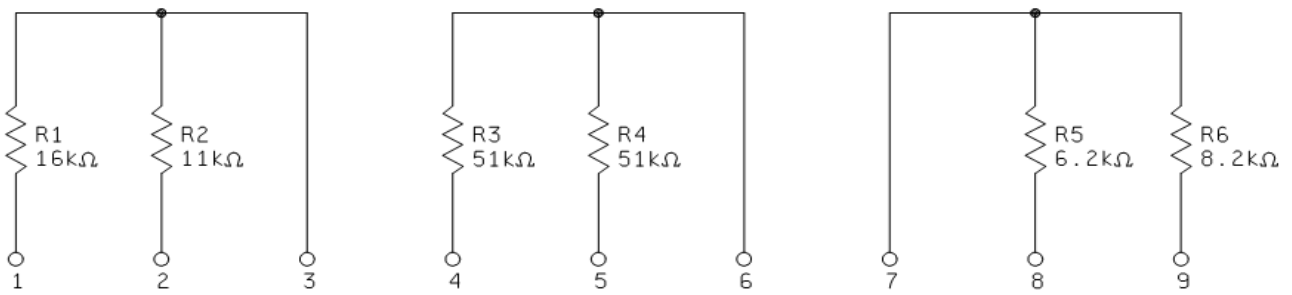

NOTES:

1. Resistor tolerance shall be ± 5 percent.
2. Resistance values are in kilohms.
3. Resistor temperature coefficient shall be ± 100 ppm/ $^{\circ}$ C.

Schematic 03

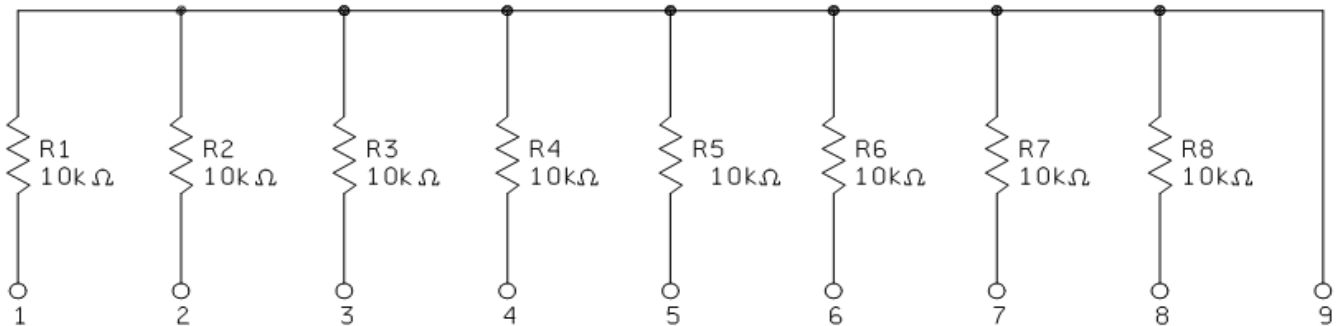

NOTES:

1. Resistor tolerance shall be ± 3 percent.
2. Resistance values are in kilohms.
3. Resistor temperature coefficient shall be ± 200 ppm/ $^{\circ}$ C.
4. Resistor power dissipation shall be capable of withstanding at least 50 mW at 120° C.

FIGURE 2. Schematic, resistance, and tolerance. Continued

DEFENSE ELECTRONIC SUPPLY CENTER DAYTON, OHIO	SIZE A	CODE IDENT NO. 14933	DWG NO. 87103
		REV E	PAGE 4

Schematic 04

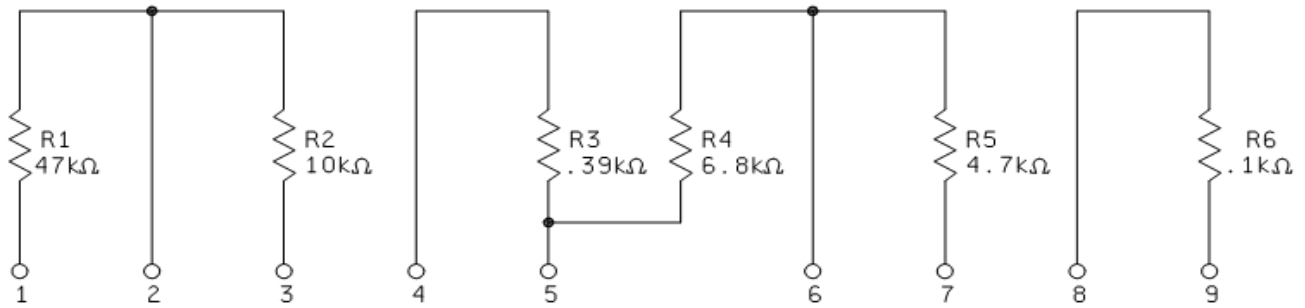

NOTES:

1. Resistor tolerance shall be ± 3 percent.
2. Resistance values are in kilohms.
3. Resistor temperature coefficient shall be ± 200 ppm/ $^{\circ}$ C.
4. Power rating for R3 and R6 shall be 50 mW at 120° C. R1, R2, R4, and R5's power rating shall be 25 mW at 120° C.

Schematic 05

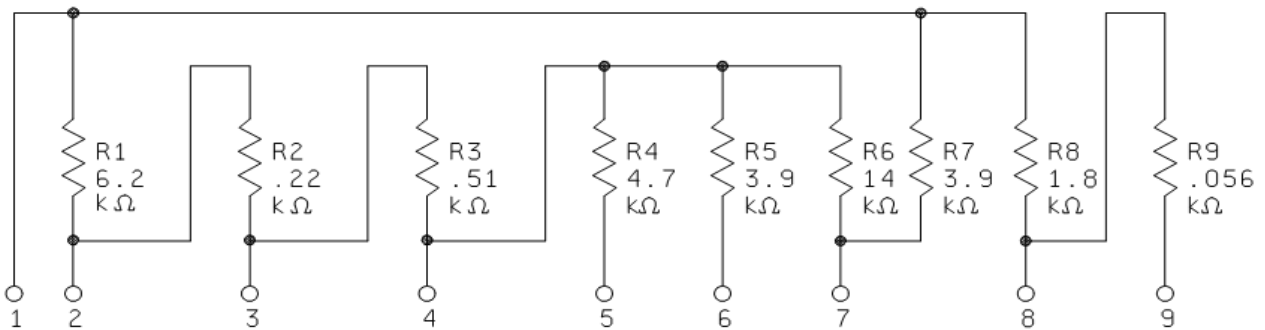

NOTES:

1. Resistor tolerance shall be ± 3 percent.
2. Resistance values are in kilohms.
3. Resistor temperature coefficient shall be ± 100 ppm/ $^{\circ}$ C.
4. Power rating for R3 and R9 shall be 60 mW at 120° C. R1, R2, R4, R5, R6, R7, and R8's power rating shall be 25 mW at 120° C.

FIGURE 2. Schematic, resistance, and tolerance - Continued.

DEFENSE ELECTRONIC SUPPLY CENTER DAYTON, OHIO	SIZE A	CODE IDENT NO. 14933	DWG NO. 87103
		REV E	PAGE 5

Schematic 06

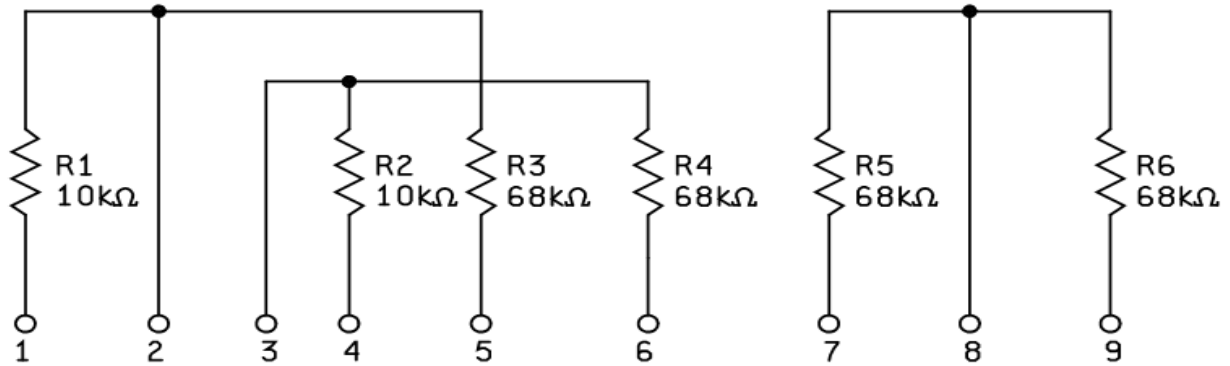

NOTES:

1. Resistor tolerance shall be ± 1 percent.
2. Resistance values are in kilohms.
3. Resistor temperature coefficient shall be ± 100 ppm/ $^{\circ}$ C.

Schematic 07

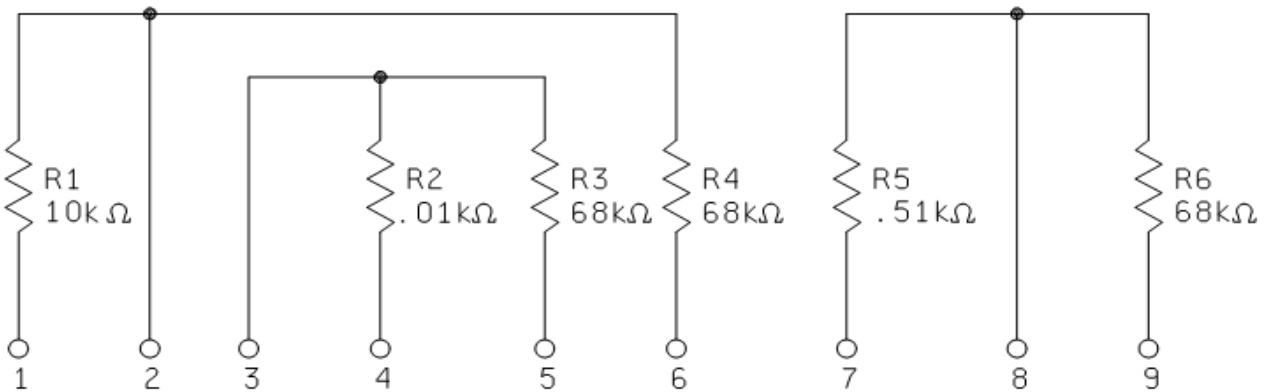

NOTES:

1. Resistor tolerance shall be ± 1 percent.
2. Resistance values are in kilohms.
3. Resistor temperature coefficient shall be ± 100 ppm/ $^{\circ}$ C.

FIGURE 2. Schematic, resistance, and tolerance - Continued.

DEFENSE ELECTRONIC SUPPLY CENTER DAYTON, OHIO	SIZE A	CODE IDENT NO. 14933	DWG NO. 87103
		REV E	PAGE 6

Schematic 08

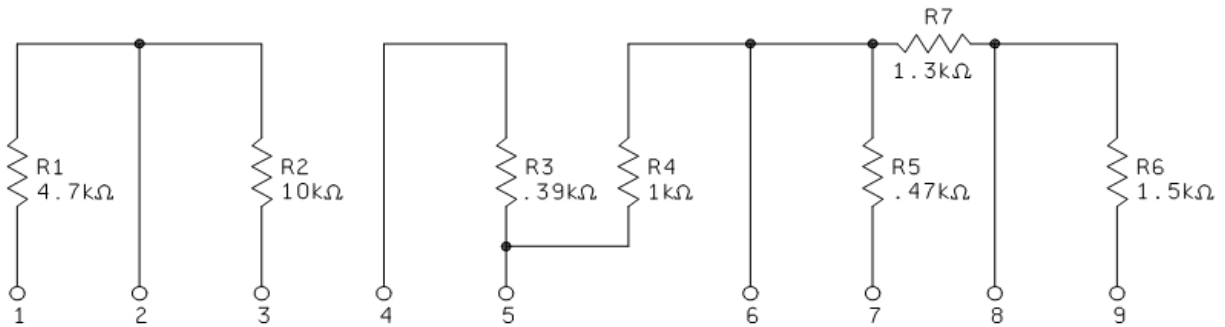

NOTES:

1. Resistor tolerance shall be ± 3 percent.
2. Resistance values are in kilohms.
3. Resistor temperature coefficient shall be ± 200 ppm/ $^{\circ}$ C.
4. Power rating for R3 and R5 shall be 50 mW at 120° C. R1, R2, R4, R6, and R7's power rating shall be 25 mW at 120° C.

Schematic 09

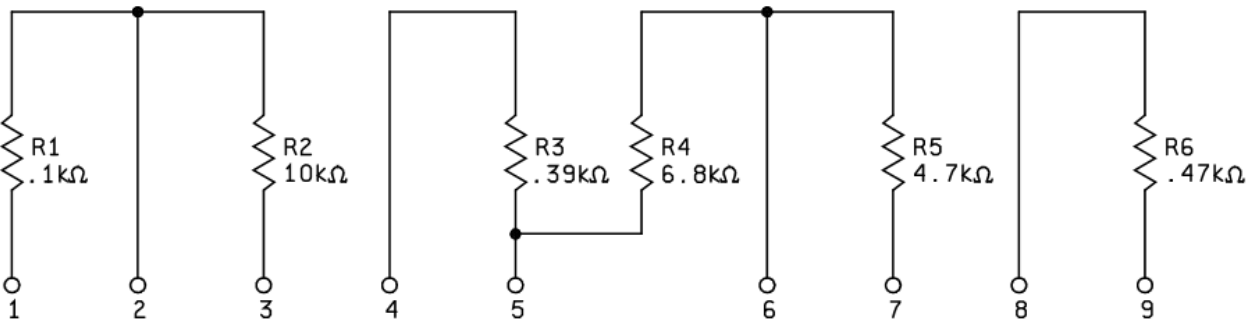

NOTES:

1. Resistor tolerance shall be ± 3 percent.
2. Resistance values are in kilohms.
3. Resistor temperature coefficient shall be ± 200 ppm/ $^{\circ}$ C.
4. Power rating for R3 and R6 shall be 50 mW at 120° C. R1, R2, R4, and R5's power rating shall be 25 mW at 120° C.

FIGURE 2. Schematic, resistance, and tolerance - Continued.

DEFENSE ELECTRONIC SUPPLY CENTER DAYTON, OHIO	SIZE A	CODE IDENT NO. 14933	DWG NO. 87103
		REV E	PAGE 7

Schematic 10

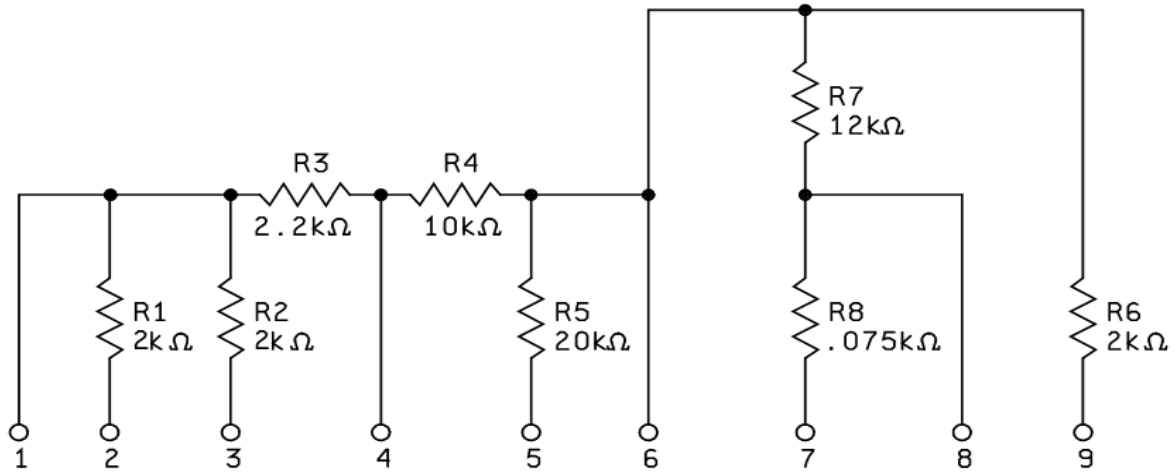

NOTES:

1. Resistor tolerance shall be ± 2 percent.
2. Resistance values are in kilohms.
3. Resistor temperature coefficient shall be ± 200 ppm/ $^{\circ}$ C.
4. Power rating shall be 25 mW at 120° C.

Schematic 11

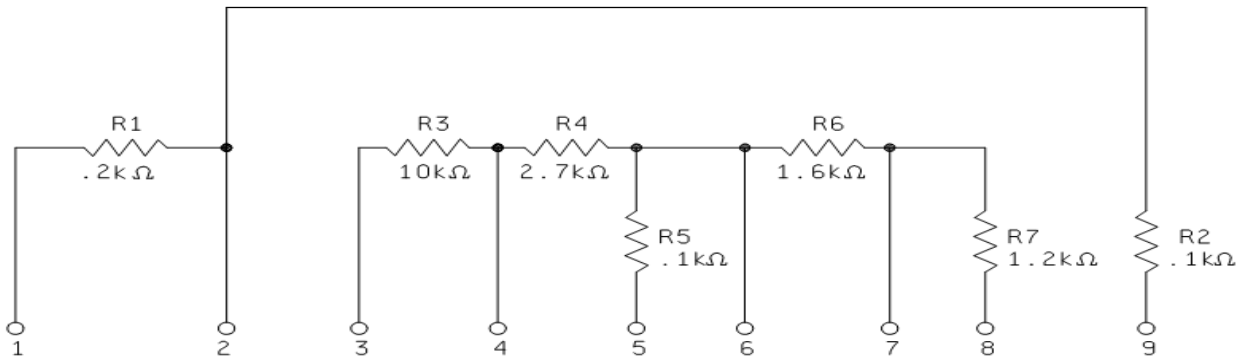

NOTES:

1. Resistor tolerance shall be ± 2 percent.
2. Resistance values are in kilohms.
3. Resistor temperature coefficient shall be ± 200 ppm/ $^{\circ}$ C.
4. Power rating shall be 25 mW at 120° C.

FIGURE 2. Schematic, resistance, and tolerance - Continued.

DEFENSE ELECTRONIC SUPPLY CENTER DAYTON, OHIO	SIZE A	CODE IDENT NO. 14933	DWG NO. 87103
		REV E	PAGE 8

Schematic 12

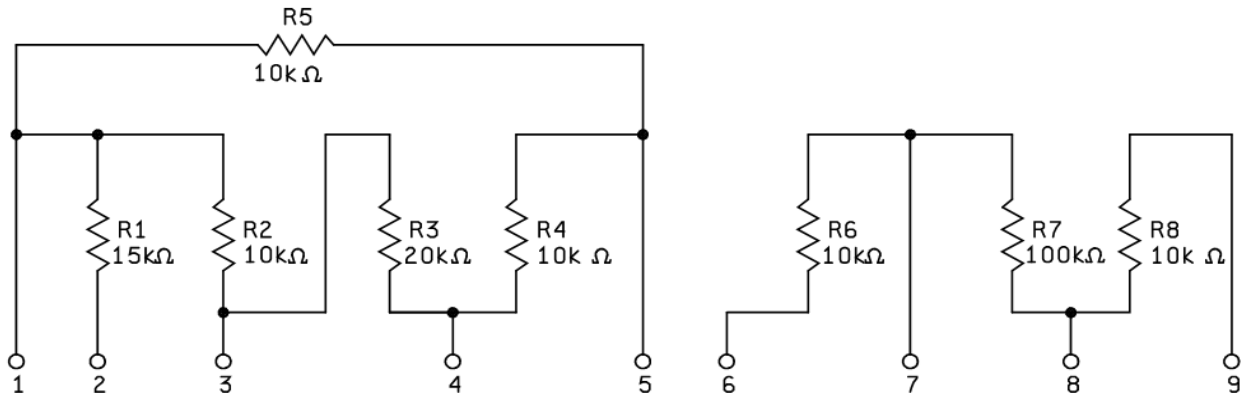

NOTES:

1. Resistor tolerance shall be ± 2 percent.
2. Resistance values are in kilohms.
3. Resistor temperature coefficient shall be ± 200 ppm/ $^{\circ}$ C.
4. Power rating shall be 25 mW at 120 $^{\circ}$ C.

Schematic 13

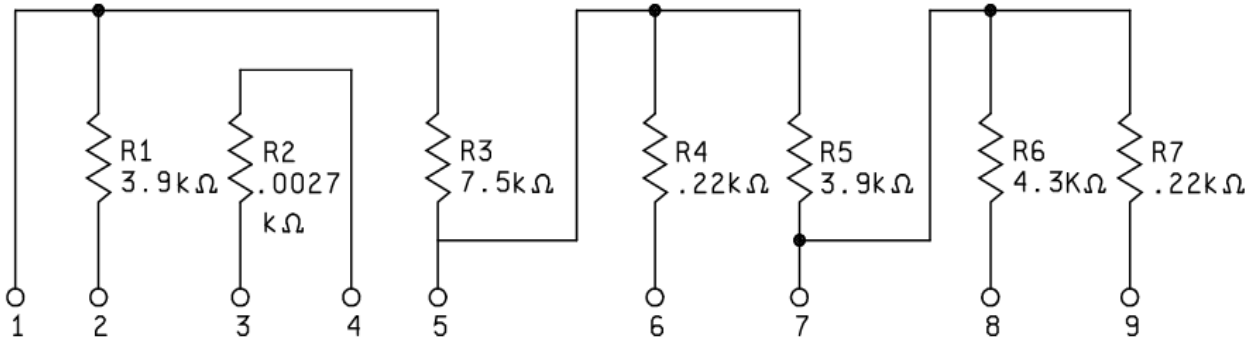

NOTES:

1. Resistor tolerance shall be ± 5 percent for R1, R2, R3, R4, and R5's resistance tolerance shall be ± 3 percent.
2. Resistance values are in kilohms.
3. Resistor temperature coefficient shall be ± 200 ppm/ $^{\circ}$ C.

FIGURE 2. Schematic, resistance, and tolerance - Continued.

DEFENSE ELECTRONIC SUPPLY CENTER DAYTON, OHIO	SIZE A	CODE IDENT NO. 14933	DWG NO. 87103
		REV E	PAGE 9

Schematic 14

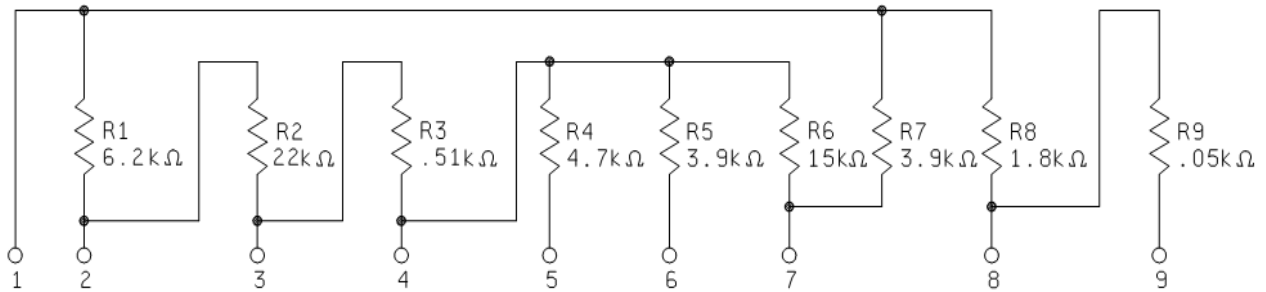

NOTES:

1. Resistor tolerance shall be ± 3 percent.
2. Resistance values are in kilohms.
3. Resistor temperature coefficient shall be ± 200 ppm/ $^{\circ}$ C.
4. Power rating for R3 and R9 shall be 60 mW at 120° C. R1, R2, R4, R5, R6, R7, and R8's power rating shall be 25 mW at 120° C.

Schematic 15

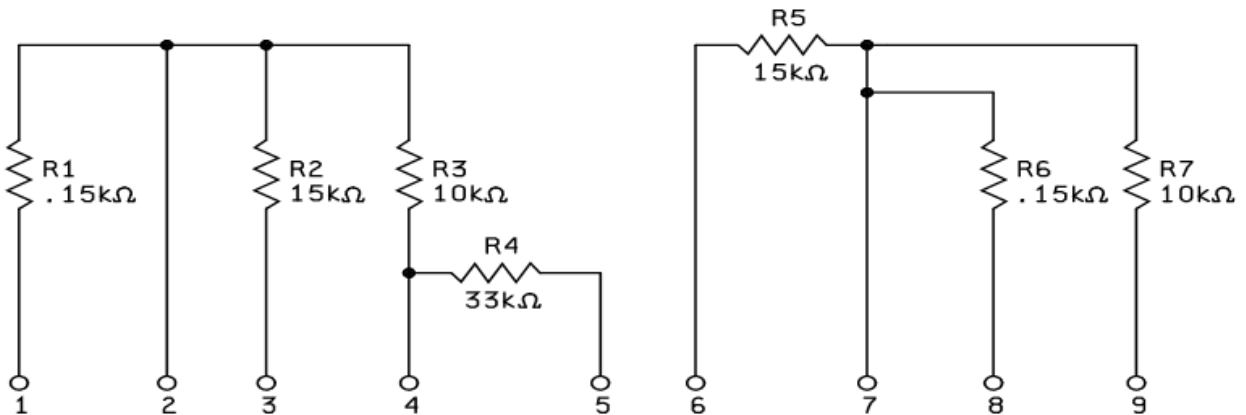

NOTES:

1. Resistor tolerance shall be ± 3 percent.
2. Resistance values are in kilohms.
3. Resistor temperature coefficient shall be ± 200 ppm/ $^{\circ}$ C.
4. Power rating for R1 and R6 shall be 60 mW at 120° C. R2, R3, R4, R5, and R7's power rating shall be 25 mW at 120° C.

FIGURE 2. Schematic, resistance, and tolerance - Continued.

DEFENSE ELECTRONIC SUPPLY CENTER DAYTON, OHIO	SIZE A	CODE IDENT NO. 14933	DWG NO. 87103
		REV E	PAGE 10

3.7 Manufacturer eligibility. To be eligible for listing as an approved source of supply, a manufacturer shall be listed on the [MIL-PRF-83401 Qualified Products List](#) for at least one part, or perform the group A and group B inspections specified herein on a sample of parts agreed upon by the manufacturer and DLA Land and Maritime - VAT.

3.7.1 Certificate of compliance. A certificate of compliance shall be required from manufacturers requesting to be a approved source of supply.

3.8 Pure tin. The use of pure tin, as an underplate or final finish, is prohibited both internally and externally. Tin content of resistor components and solder shall not exceed 97 percent, by mass. Tin shall be alloyed with a minimum of 3 percent lead, by mass (see [6.3](#)).

3.9 Recycled, recovered, environmentally preferable, or biobased materials. Recycled, recovered, environmentally preferable, or biobased materials should be used to the maximum extent possible, provided that the material meets or exceeds the operational and maintenance requirements, and promotes economically advantageous life cycle costs.

3.10 Workmanship. Resistors shall be uniform in quality and free from defects that will affect life, serviceability, or appearance.

4. VERIFICATION

4.1 Qualification inspection. Qualification inspection is not applicable to this document.

4.2 Conformance inspections.

4.2.1 Inspection of product for delivery. Inspection of product for delivery shall consist of group A and group B inspections of [MIL-PRF-83401](#).

4.2.2 Certification. The acquiring activity, at its discretion, may accept a certificate of compliance with group B requirements in lieu of performing group B tests (see [6.2d](#)).

4.3 Inspection of packaging. Inspection of packaging shall be in accordance with [MIL-PRF-83401](#).

4.4 Visual and mechanical examination. Resistors shall be examined to verify that the materials, design, construction, physical dimensions, marking, and workmanship are in accordance with the applicable requirements of [MIL-PRF-83401](#).

5. PACKAGING

5.1 Packaging. For acquisition purposes, the packaging requirements shall be as specified in the contract or order (see [6.2](#)). When packaging of materiel is to be performed by DoD or in-house contractor personnel, these personnel need to contact the responsible packaging activity to ascertain packaging requirements. Packaging requirements are maintained by the Inventory Control Point's packaging activities within the Military Service or Defense Agency, or within the military service's system commands. Packaging data retrieval is available from the managing Military Department's or Defense Agency's automated packaging files, CD-ROM products, or by contacting the responsible packaging activity.

6. NOTES

(This section contains information of a general or explanatory nature that may be helpful, but is not mandatory.)

6.1 Intended use. Resistor networks are used in surface mounting applications where space is a major concern.

6.2 Ordering data. The contract or purchase order should specify the following:

- a. Complete DLA Land and Maritime CAGE CODE (037Z3) and PIN (see [1.2](#)).
- b. Requirements for delivery: One copy of the conformance inspection data or certification of compliance that parts have passed conformance inspection with each shipment of parts by the manufacturer.
- c. Requirements for packaging and packing. (i.e. ESD sensitive packaging).
- d. Whether the manufacturer performs the group B tests or provides certification of compliance with group B requirements.

6.3 Electrostatic charge. Under several combinations of conditions, these resistors can be electrically damaged, by electrostatic charges, and drift from specified value. Users should consider this phenomena when ordering or shipping resistors. Direct shipment to the Government is controlled by [MIL-DTL-39032](#) which specifies a preventive packaging procedure.

DEFENSE ELECTRONIC SUPPLY CENTER DAYTON, OHIO	SIZE A	CODE IDENT NO. 14933	DWG NO. 87103
		REV E	PAGE 11

6.4 Tin whisker growth. The use of alloys with tin content greater than 97 percent, by mass, may exhibit tin whisker growth problems after manufacture. Tin whiskers may occur anytime from a day to years after manufacture and can develop under typical operating conditions, on products that use such materials. Conformal coatings applied over top of a whisker-prone surface will not prevent the formation of tin whiskers. Alloys of 3 percent lead, by mass, have shown to inhibit the growth of tin whiskers. For additional information on this matter, refer to [ASTM-B545](#) (Standard Specification for Electrodeposited Coatings of Tin).

6.5 User of record. Coordination of this document for future revisions is coordinated only with the approved source of supply and the users of record of this document. Requests to be added as a recorded user of this drawing may be achieved online at resistor@dla.mil or in writing to: DLA Land and Maritime-VAT, Post Office Box 3990, Columbus, OH 43218-3990 or by telephone (614) 692-4546 or DSN 850-4546.

6.6 Approved source of supply. Approved source of supply is listed herein. Additional sources will be added as they become available. Assistance in the use of this drawing may be obtained online at resistor@dla.mil or contact DLA Land and Maritime-VAT, Post Office Box 3990, Columbus, OH 43218-3990 or by telephone (614) 692-4546 or DSN 850-4546.

DLA Land and Maritime drawing PIN	Vendors similar designation or type number <u>1/</u>	Vendor CAGE	Vendor's name and address
87103-**	9SM-XXXX-FX	91637	Vishay Techno P.O. Box 609, 1122 23rd St., Columbus, NE 68602-0609 http://www.vishay.com/

1/ Parts must be purchased to the DLA Land and Maritime CAGE CODE (037Z3) and PIN to assure that all performance and test requirements are met.

DEFENSE ELECTRONIC SUPPLY CENTER DAYTON, OHIO	SIZE A	CODE IDENT NO. 14933	DWG NO. 87103
		REV E	PAGE 12