

REVISIONS			
LTR	DESCRIPTION	DATE (YR-MO-DA)	APPROVED
A	Editorial changes throughout. Add QR code. Update Vendor's address.	16-08-10	M. A. Radecki
B	Editorial changes throughout and update vendor's address.	21-07-21	RADECKI.MIC HAELA.12301 52051 <small>Digitally signed by RADECKI.MICHAEL.A.1 230152051 Date: 2021.07.21 12:26:37 -04'00'</small>

CURRENT DESIGN ACTIVITY CAGE CODE 037Z3  
HAS CHANGED NAMES TO:  
DLA LAND AND MARITIME  
COLUMBUS, OHIO 43218-5000



Prepared in accordance with [ASME Y14.100](#)

Selected Item Drawing

REV STATUS OF PAGES	REV	B	B	B	B	B	B	B	B	B	B								
	PAGES	1	2	3	4	5	6	7	8	9	10	11							
PMIC N/A	PREPARED BY	Patrick Kyne																	
Original date of drawing  10-04-09	CHECKED BY	Kenneth A. Bernier																	
	APPROVED BY	Michael A. Radecki																	
	SIZE A	CODE IDENT. NO.	037Z3																
	REV	B	PAGE 1 OF 11																
	DESIGN ACTIVITY	DEFENSE SUPPLY CENTER COLUMBUS, DAYTON, OH																	
	TITLE	FILTER, EMI, HYBRID, 15 Amp																	
	DWG NO.	10018																	

1. SCOPE

1.1 Scope. This drawing describes the requirements for hybrid microcircuit electromagnetic interference (EMI) suppression filters to be processed in accordance with [MIL-PRF-38534](#). Two product assurance classes consisting of class H (military high reliability) and class K (space application) and a choice of case outlines and lead finishes are reflected in the Part or Identifying Number (PIN). When available, a choice of radiation hardness assurance (RHA) levels are reflected in the PIN.

1.2 Part or Identifying Number (PIN). The complete PIN is as shown in the following example:

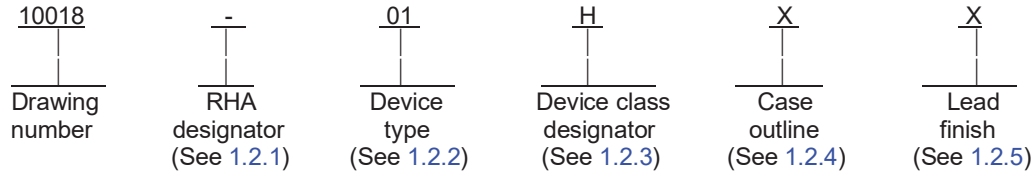

1.2.1 Radiation hardness assurance (RHA) designator. Device classes H and K RHA marked devices meet the [MIL-PRF-38534](#) specified RHA levels and should be marked with the appropriate RHA designator. A dash (-) indicates a non-RHA device.

1.2.2 Device types. The device type identifies the circuit function as follows:

<u>Device type</u>	<u>Generic number</u>	<u>Circuit function</u>
01	FMCE-1528	EMI filter, 15 A

1.2.3 Device class designator. This device class designator is a single letter identifying the product assurance level as follows:

<u>Device class</u>	<u>Device requirements documentation</u>
H	Standard military reliability level. This level is intended for use in applications where non-space high reliability devices are required. Certification and qualification to <a href="#">MIL-PRF-38534</a> is required.
K	Highest reliability class available. This level is intended for use in space applications. Certification and qualification to <a href="#">MIL-PRF-38534</a> is required.

1.2.4 Case outline. The case outline is designated in [MIL-STD-1835](#), and as follows:

<u>Outline letter</u>	<u>Case outline</u>	<u>Package style</u>
T	See <a href="#">figure 1</a>	Tabbed flange mount, lead formed up
U	See <a href="#">figure 2</a>	Flange mount, lead formed down
X	See <a href="#">figure 3</a>	Flange mount, short lead
Y	See <a href="#">figure 4</a>	Tabbed flange mount, short lead
Z	See <a href="#">figure 5</a>	Tabbed flange mount, lead formed down

1.2.5 Lead finish. The lead finish is as specified in [MIL-PRF-38534](#) for classes H and K. Finish letter "X" will not be marked on the filter or its packaging. The "X" designation is for use when lead finishes A, B, or C are considered acceptable and interchangeable without preference.

1.3 Absolute maximum ratings. <sup>1/</sup>

Input voltage-----	-0.5 V dc to +80 V dc
Input current-----	15 A
Power dissipation-----	16 W
Lead temperature (soldering, 10 seconds)-----	+300° C
Storage temperature-----	-65° C to +150° C

<sup>1/</sup> Stresses above the absolute maximum rating may cause permanent damage to the device. Input voltage transients between 50 V to 80 V are allowed for no more than 100 milliseconds. Extended operation at the maximum levels may degrade performance and affect reliability.

<b>DEFENSE SUPPLY CENTER COLUMBUS, COLUMBUS, OHIO</b>	<b>SIZE A</b>	<b>CODE IDENT NO. 037Z3</b>	<b>DWG NO. 10018</b>
		REV B	PAGE 2

1.4 Recommended operating conditions.

Input voltage----- -0.5 to +50 V dc  
Case operating temperature range ----- -55° C to +125° C

2. APPLICABLE DOCUMENTS

2.1 General. The documents listed in this section are specified in sections 3 and 4 of this drawing. This section does not include documents cited in other sections of this drawing or recommended for additional information or as examples. While every effort has been made to ensure the completeness of this list, document users are cautioned that they must meet all specified requirements of documents in sections 3 and 4 of this drawing, whether or not they are listed here.

2.2 Government documents.

2.2.1 Specifications, standards, and handbooks. The following specifications, standards, and handbooks form a part of this document to the extent specified herein. Unless otherwise specified, the issues of these documents are those cited in the solicitation or contract.

DEPARTMENT OF DEFENSE SPECIFICATIONS

**MIL-PRF-38534** - Hybrid Microcircuits, General Specification for.

DEPARTMENT OF DEFENSE STANDARDS

**MIL-STD-883** - Test Methods Standard Microcircuits.

**MIL-STD-883-1** - Environmental Test Methods for Microcircuits Part 1: Test Methods 1000-1999.

(Copies of these documents are available online at <https://quicksearch.dla.mil/>)

2.3 Order of precedence. Unless otherwise noted herein or in the contract, in the event of a conflict between the text of this document and the references cited herein, the text of this document takes precedence. Nothing in this document, however, supersedes applicable laws and regulations unless a specific exemption has been obtained.

3. REQUIREMENTS

3.1 Item requirements. The individual item requirements shall be in accordance with **MIL-PRF-38534** and as specified herein.

3.2 Interface and physical dimensions. The interface and physical dimensions shall be as specified in **MIL-PRF-38534** and as specified herein.

3.2.1 Case outline. The case outline shall be in accordance with 1.2.4 and on figures 1 through 5 herein.

3.2.2 Terminal connections. The terminal connections shall be as specified on figures 1 through 5 herein.

3.3 Pure tin prohibition. The use of pure tin as an underplate or final finish in the internal or external construction of the filter and the terminations is prohibited. This includes the discrete devices and solders used internal to the case. Tin shall be alloyed with a minimum of 3 percent lead, by mass. The use of tin alloys other than lead is permissible as specified in APPENDIX E of **MIL-PRF-38534**.

3.4 Electrical performance characteristics. Unless otherwise specified herein, the electrical performance characteristics are as specified in table I and shall apply over the full specified operating temperature range.

3.5 Electrical test requirements. The electrical test requirements shall be the subgroups specified in table II. The electrical tests for each subgroup are defined in table I.

3.6 Marking. Marking shall be in accordance with **MIL-PRF-38534**. The part shall be marked with the PIN listed in 1.2 herein. In addition, the manufacturer's PIN may also be marked as listed on QML-38534.

<b>DEFENSE SUPPLY CENTER COLUMBUS, COLUMBUS, OHIO</b>	<b>SIZE A</b>	<b>CODE IDENT NO. 037Z3</b>	<b>DWG NO. 10018</b>
		<b>REV B</b>	<b>PAGE 3</b>

3.7 Manufacturer eligibility. To be eligible for listing as an approved source of supply, the manufacturer shall be certified and qualified to MIL-PRF-38534. In addition to the general requirements of MIL-PRF-38534, the manufacturer of the part described herein shall maintain the electrical test data (variables format) from the initial quality conformance inspection group A lot sample, produced on the certified line, for each device type listed herein. The data should also include a summary of all parameters manually tested, and for those which, if any, are guaranteed. This data shall be maintained under document revision level control by the manufacturer and be made available to the preparing activity (DLA Land and Maritime-VA) upon request.

3.8 Certificate of compliance. A certificate of compliance shall be required from a manufacturer in order to supply to this drawing. The certificate of compliance submitted to DLA Land and Maritime-VA shall affirm that the manufacturer's product meets the requirements of MIL-PRF-38534 and the requirements herein.

3.9 Certificate of conformance. A certificate of conformance as required in MIL-PRF-38534 shall be provided with each lot of filters delivered to this drawing.

3.10 Recycled, recovered, environmentally preferable, or biobased materials. Recycled, recovered, environmentally preferable, or biobased materials should be used to the maximum extent possible provided that the material meets or exceeds the operational and maintenance requirements, and promotes economically advantageous life cycle costs.

3.11 Workmanship. Filters shall be processed in such a manner as to be uniform in quality and shall be free from cold soldering, corrosion, pits, dents, cracks, rough or sharp edges, misalignments and other defects that will affect life, serviceability, or appearance.

TABLE I. Electrical performance characteristics.

Test	Symbol	Conditions -55°C ≤ Tc ≤ +125°C unless otherwise specified	Group A subgroup	Device types	Limits		Units
					Min	Max	
Input voltage	V <sub>in</sub>		1,2,3	All	0	50	V
Noise reduction	NO	f = 500 kHz	4,5,6	All	60	----	dB
		f = 1 MHz	4,5,6	All	60	----	
DC resistance	R <sub>dc</sub>		1	All	----	.07	Ω
Isolation	ISO	Any pin to case, 500 V dc	1	All	100	----	MΩ
Capacitance	CAP	Any pin to case	1	All	50,000	70,000	pF

<b>DEFENSE SUPPLY CENTER COLUMBUS, COLUMBUS, OHIO</b>	<b>SIZE A</b>	<b>CODE IDENT NO. 037Z3</b>	<b>DWG NO. 10018</b>
		<b>REV B</b>	<b>PAGE 4</b>

### Case outline T

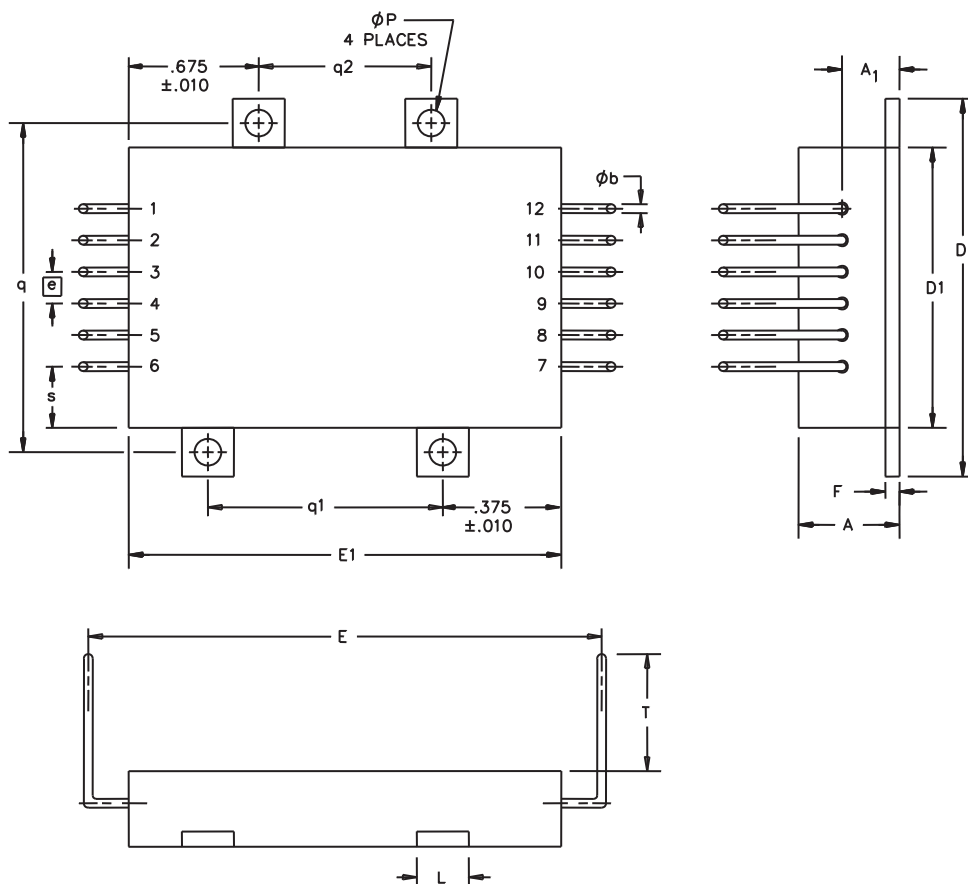

Symbol	Millimeters		Inches	
	Min	Max	Min	Max
A		10.16		0.400
A1	5.33	5.84	0.210	0.230
$\phi b$	0.89	1.14	0.035	0.045
D	50.55	51.05	1.990	2.010
D1	37.85	38.35	1.490	1.510
e	5.08 BSC		0.200 BSC	
E	69.85	72.39	2.750	2.850
E1	63.25	63.75	2.490	2.510
F	1.14	1.40	0.045	0.055
L	6.10	6.60	0.240	0.260
$\phi P$	3.43	3.68	0.135	0.145
q/q1	44.20	44.70	1.740	1.760
q2	28.96	29.46	1.140	1.160
s	6.10	6.60	0.240	0.260
T	10.92	11.43	0.430	0.450

Device type	01
Case outline	T(Figure 1)
Terminal number	Terminal symbol
1, 2, 3	+V <sub>in</sub>
10, 11, 12	+V <sub>out</sub>
*	case ground
7, 8, 9	output return
4, 5, 6	input return

\* NOTE: Case ground connection is made by contact of the base plate to the chassis.

#### NOTES:

- Dimensions are in inches. The case outline was originally designed using inch-pound units of measurement. In the event of conflict between the metric and inch-pound units, the inch-pound shall take precedence.
- Device weight: 86 grams maximum.

FIGURE 1. Case outline T configuration, dimensions and terminal connections.

<b>DEFENSE SUPPLY CENTER COLUMBUS, COLUMBUS, OHIO</b>	<b>SIZE A</b>	<b>CODE IDENT NO. 037Z3</b>	<b>DWG NO. 10018</b>
		<b>REV B</b>	<b>PAGE 5</b>

Case outline U

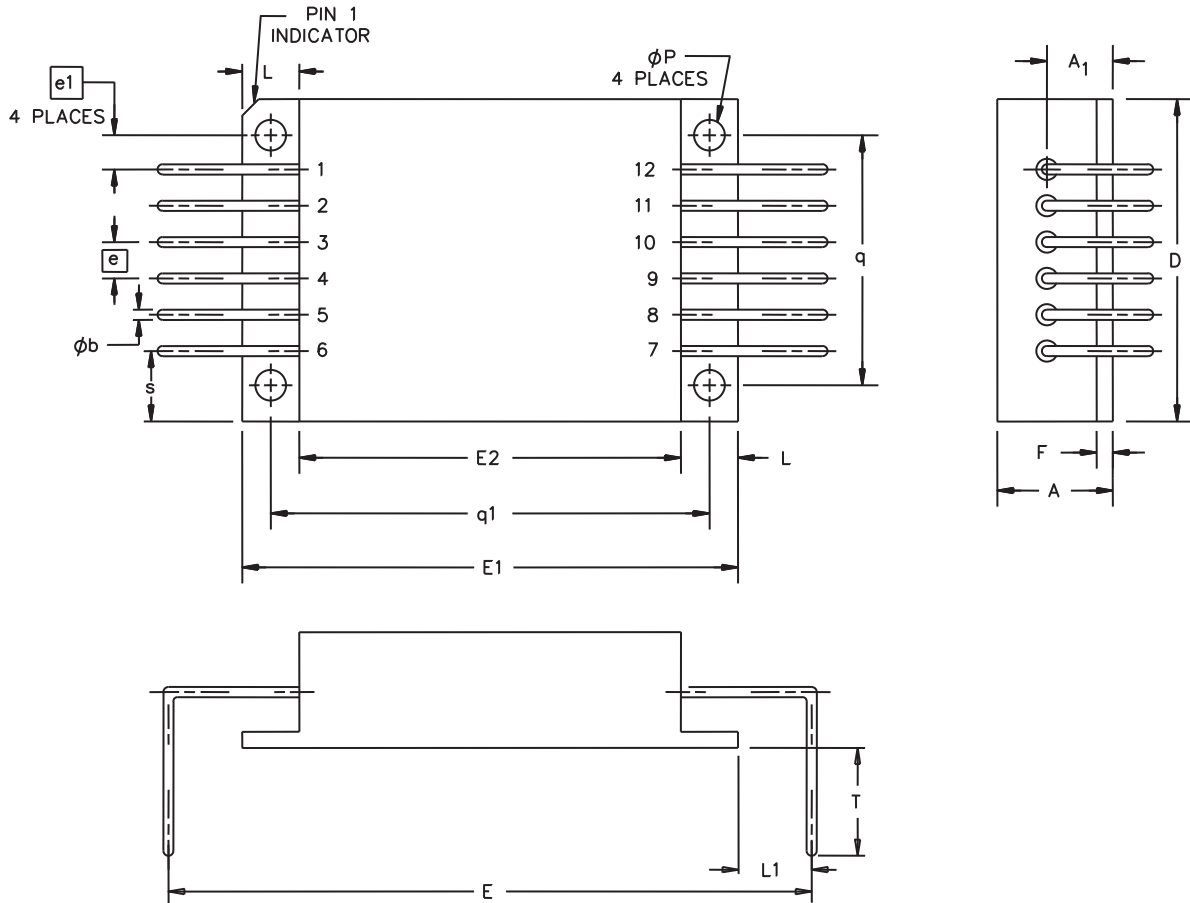

Symbol	Millimeters		Inches	
	Min	Max	Min	Max
A				
A1	5.46	10.16	0.215	0.400
$\phi b$	0.89	1.14	0.035	0.045
D	37.97	38.23	1.495	1.505
e	5.08 BSC		0.200 BSC	
e1	3.30 BSC		0.130 BSC	
E	87.38	87.88	3.440	3.460
E1	75.95	76.45	2.990	3.010
E2	63.37	63.63	2.495	2.505
F	1.14	1.40	0.045	0.055
L	6.10	6.60	0.240	0.260
L1	5.59	5.84	0.220	0.230
$\phi P$	3.12	3.38	0.123	0.133
q	31.88	32.13	1.255	1.265
q1	69.85	70.36	2.750	2.770
S	6.22	6.48	0.245	0.255
T	5.08	7.62	0.200	0.300

Device type	01
Case outline	U(Figure 2)
Terminal number	Terminal symbol
1, 2, 3	+V <sub>in</sub>
10, 11, 12	+V <sub>out</sub>
*	case ground
7, 8, 9	output return
4, 5, 6	input return

\* NOTE: Case ground connection is made by contact of the base plate to the chassis.

NOTES:

1. Dimensions are in inches. The case outline was originally designed using inch-pound units of measurement. In the event of conflict between the metric and inch-pound units, the inch-pound shall take precedence.
2. Device weight: 86 grams maximum.

FIGURE 2. Case outline U configuration, dimensions and terminal connections.

<b>DEFENSE SUPPLY CENTER COLUMBUS, COLUMBUS, OHIO</b>	<b>SIZE A</b>	<b>CODE IDENT NO. 037Z3</b>	<b>DWG NO. 10018</b>
		<b>REV B</b>	<b>PAGE 6</b>

Case outline X

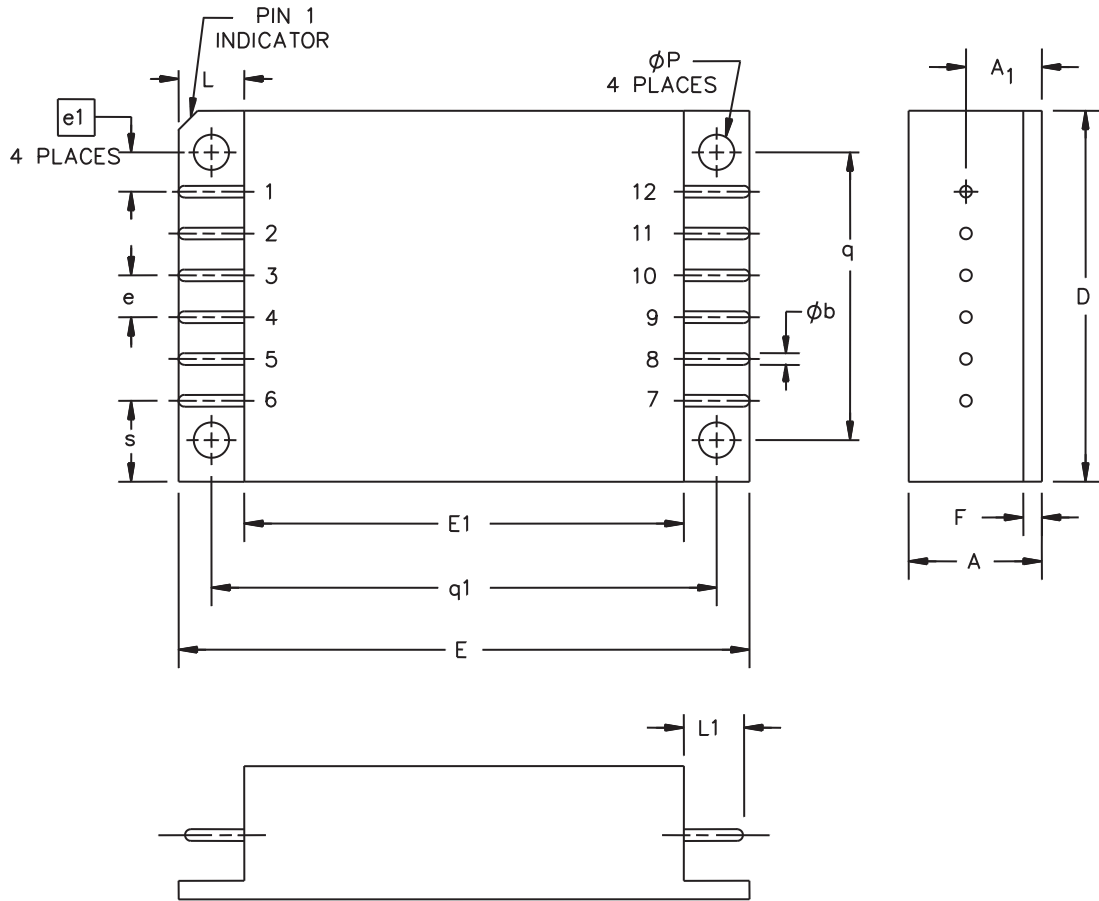

Symbol	Millimeters		Inches	
	Min	Max	Min	Max
A		10.16		0.400
A1	5.46	5.72	0.215	0.225
$\phi b$	0.89	1.14	0.035	0.045
D	37.97	38.23	1.495	1.505
e	5.08 BSC		.200 BSC	
e1	3.30 BSC		.130 BSC	
E	75.95	76.46	2.990	3.010
E1	63.37	63.63	2.495	2.505
F	1.14	1.40	0.045	0.055
L	6.10	6.60	0.240	0.260
L1	5.58	6.10	0.220	0.240
$\phi P$	3.12	3.38	0.123	0.133
q	31.88	32.13	1.255	1.265
q1	69.97	70.23	2.755	2.765
s	6.22	6.48	0.245	0.255

Device type	01
Case outline	X(Figure 3)
Terminal number	Terminal symbol
1, 2, 3	+V <sub>in</sub>
10, 11, 12	+V <sub>out</sub>
*	case ground
7, 8, 9	output return
4, 5, 6	input return

\* NOTE: Case ground connection is made by contact of the base plate to the chassis.

NOTES:

- Dimensions are in inches. The case outline was originally designed using inch-pound units of measurement. In the event of conflict between the metric and inch-pound units, the inch-pound shall take precedence.
- Device weight: 86 grams maximum.

FIGURE 3. Case outline X configuration, dimensions and terminal connections.

<b>DEFENSE SUPPLY CENTER COLUMBUS, COLUMBUS, OHIO</b>	<b>SIZE A</b>	<b>CODE IDENT NO. 037Z3</b>	<b>DWG NO. 10018</b>
		<b>REV B</b>	<b>PAGE 7</b>

Case outline Y

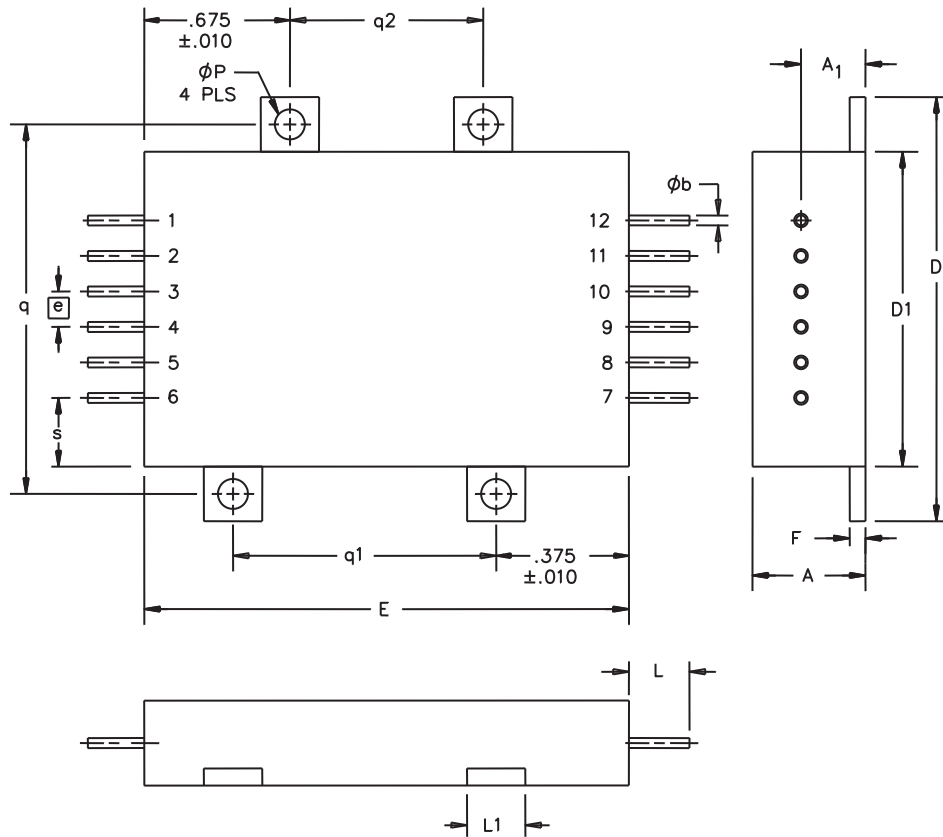

Symbol	Millimeters		Inches	
	Min	Max	Min	Max
A		10.16		0.400
A1	5.33	5.84	0.210	0.230
$\phi b$	0.89	1.14	0.035	0.045
D	50.55	51.05	1.990	2.010
D1	37.85	38.35	1.490	1.510
e	5.08 BSC		0.200 BSC	
E	63.25	63.75	2.490	2.510
F	1.14	1.40	0.045	0.055
L	6.99	8.26	0.275	0.325
L1	6.10	6.60	0.240	0.260
$\phi P$	3.43	3.68	0.135	0.145
q/q1	44.20	44.70	1.740	1.760
q2	28.96	29.46	1.140	1.160
s	6.10	6.60	0.240	0.260

Device type	01
Case outline	Y(Figure 4)
Terminal number	Terminal symbol
1, 2, 3	+V <sub>in</sub>
10, 11, 12	+V <sub>out</sub>
*	case ground
7, 8, 9	output return
4, 5, 6	input return

\* NOTE: Case ground connection is made by contact of the base plate to the chassis.

NOTES:

1. Dimensions are in inches. The case outline was originally designed using inch-pound units of measurement. In the event of conflict between the metric and inch-pound units, the inch-pound shall take precedence.
2. Device weight: 86 grams maximum.

FIGURE 4. Case outline Y configuration, dimensions and terminal connections.

<b>DEFENSE SUPPLY CENTER COLUMBUS, COLUMBUS, OHIO</b>	<b>SIZE A</b>	<b>CODE IDENT NO. 037Z3</b>	<b>DWG NO. 10018</b>
		<b>REV B</b>	<b>PAGE 8</b>

Case outline Z

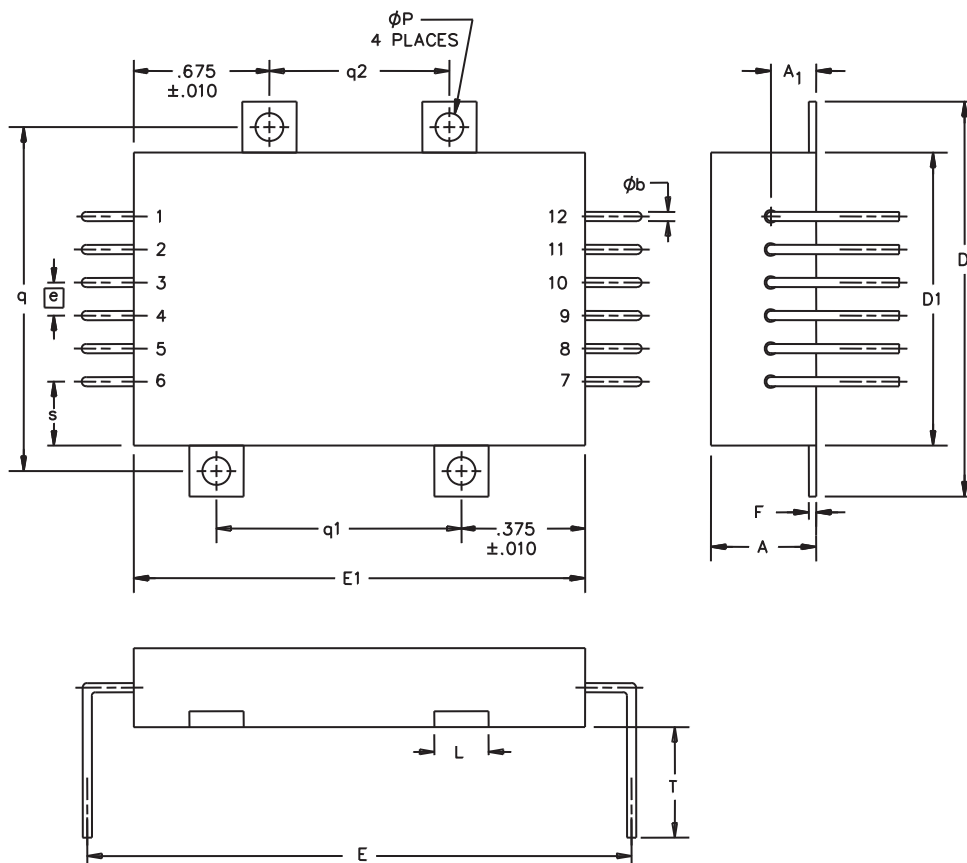

Symbol	Millimeters		Inches	
	Min	Max	Min	Max
A		10.16		0.400
A1	5.33	5.84	0.210	0.230
φb	0.89	1.14	0.035	0.045
D	50.55	51.05	1.990	2.010
D1	37.85	38.35	1.490	1.510
e	5.08 BSC		0.200 BSC	
E	69.85	72.39	2.750	2.850
E1	63.25	63.75	2.490	2.510
F	1.14	1.40	0.045	0.055
L	6.10	6.60	0.240	0.260
φP	3.43	3.68	0.135	0.145
q/q1	44.20	44.70	1.740	1.760
q2	28.96	29.46	1.140	1.160
s	6.10	6.60	0.240	0.260
T	8.64	9.65	0.340	0.380

Device type	01
Case outline	Z(Figure 5)
Terminal number	Terminal symbol
1, 2, 3	+V <sub>in</sub>
10, 11, 12	+V <sub>out</sub>
*	case ground
7, 8, 9	output return
4, 5, 6	input return

\* NOTE: Case ground connection is made by contact of the base plate to the chassis.

NOTES:

- Dimensions are in inches. The case outline was originally designed using inch-pound units of measurement. In the event of conflict between the metric and inch-pound units, the inch-pound shall take precedence.
- Device weight: 86 grams maximum.

FIGURE 5. Case outline Z configuration, dimensions and terminal connections.

<b>DEFENSE SUPPLY CENTER COLUMBUS, COLUMBUS, OHIO</b>	<b>SIZE A</b>	<b>CODE IDENT NO. 037Z3</b>	<b>DWG NO. 10018</b>
		<b>REV B</b>	<b>PAGE 9</b>

4. VERIFICATION

4.1 Sampling and inspection. Sampling and inspection procedures shall be in accordance with MIL-PRF-38534.

4.2 Screening. Screening shall be in accordance with MIL-PRF-38534. The following additional criteria shall apply:

a. Burn-in test, method 1015 of MIL-STD-883-1.

(1) Test condition A, B, C, or D. The test circuit shall be maintained by the manufacturer under document revision level control and shall be made available to DLA Land and Maritime-VA or the acquiring activity upon request. Also, the test circuit shall specify the inputs, outputs, biases, and power dissipation, as applicable, in accordance with the intent specified in test method 1015 of MIL-STD-883-1.

(2)  $T_A$  as specified in accordance with table I of method 1015 of MIL-STD-883-1.

b. Interim and final electrical test parameters shall be as specified in table II herein, except interim electrical parameter tests prior to burn-in are optional at the discretion of the manufacturer.

TABLE II. Electrical test requirements

MIL-PRF-38534 test requirements	Subgroups (in accordance with MIL-PRF-38534, group A test table)
Interim electrical parameters	1, 2, 3, 4
Final electrical parameters	1*, 2, 3, 4
Group A test requirements	1, 2, 3, 4, 5, 6
Group C end-point electrical parameters	1,2,3

\* PDA applies to subgroup 1.

4.3 Conformance inspection. Conformance inspection shall be in accordance with MIL-PRF-38534 and as specified herein.

4.3.1 Group A inspection. Group A inspection shall be in accordance with MIL-PRF-38534 and as follows:

a. Tests shall be as specified in table II herein.

b. Subgroups 7, 8, 9, 10, and 11 of MIL-PRF-38534, group A shall be omitted.

4.3.2 Group B inspection. Group B inspection shall be in accordance with MIL-PRF-38534.

4.3.3 Group C inspection. Group C inspection shall be in accordance with MIL-PRF-38534 and as follows:

a. End-point electrical parameters shall be as specified in table II herein.

b. Steady-state life test conditions, method 1005 of MIL-STD-883-1.

(1) Test conditions A, B, C, or D. The test circuit shall be maintained by the manufacturer under document revision level control and shall be made available to DLA Land and Maritime-VA or the acquiring activity upon request. Also, the test circuit shall specify the inputs, outputs, biases, and power dissipation, as applicable, in accordance with the intent specified in test method 1005 of MIL-STD-883-1.

(2)  $T_A$  as specified in accordance with table I of method 1005 of MIL-STD-883-1.

(3) Test duration: 1,000 hours, except as permitted by method 1005 of MIL-STD-883-1.

4.3.4 Group D inspection. Group D inspection shall be in accordance with MIL-PRF-38534.

4.3.5. Radiation hardness assurance (RHA). RHA inspection is not currently applicable to this drawing.

<b>DEFENSE SUPPLY CENTER COLUMBUS, COLUMBUS, OHIO</b>	<b>SIZE A</b>	<b>CODE IDENT NO. 037Z3</b>	<b>DWG NO. 10018</b>
		<b>REV B</b>	<b>PAGE 10</b>

5. PACKAGING

5.1 Packaging requirements. The requirements for packaging shall be in accordance with [MIL-PRF-38534](#).

6. NOTES

(This section contains information of a general or explanatory nature that may be helpful, but is not mandatory.)

6.1 Intended use. Filters conforming to this drawing are intended for use for Government microcircuit applications (original equipment), design applications, and logistics purposes.

6.2 Ordering data. The contract or purchase order should specify the following:

- a. Complete DLA Land and Maritime CAGE CODE and PIN (see 1.2)
- b. Requirements for delivery of one copy of the conformance inspection data or certificate of compliance that parts have passed conformance inspection with each shipment of parts by the manufacturer.
- c. Packaging Requirements (see 5.1).

6.3 Replaceability. Filters covered by this drawing will replace the same generic device covered by a contractor-prepared specification or drawing.

6.4 Configuration control. All proposed changes to this drawing will be coordinated with the sources of supply and users of record.

6.5 Changes from previous issue. The margins of this specification are marked with vertical lines to indicate where changes from the previous issue were made. This was done as a convenience only and the Government assumes no liability whatsoever for any inaccuracies in these notations. Bidders and contractors are cautioned to evaluate the requirements of this document based on the entire content irrespective of the marginal notations and relationship to the last previous issue.

6.6 Users of record. Coordination of this document for future revisions is coordinated only with the approved source(s) of supply and the users of record of this document. Requests to be added as a recorded user of this drawing may be achieved online at [capacitorfilter@dla.mil](mailto:capacitorfilter@dla.mil) or if in writing to: DLA Land and Maritime, ATTN: VAT, Post Office Box 3990, Columbus, OH 43218-3990 or by telephone (614) 692-0551 or DSN 850-0551.

6.7 Approved sources of supply. Approved source(s) of supply are listed herein. Additional sources will be added as they become available. Assistance in the use of this drawing may be obtained online at [capacitorfilter@dla.mil](mailto:capacitorfilter@dla.mil), or by contacting DLA Land and Maritime, ATTN: VAT, Post Office Box 3990, Columbus, OH 43218-3990 or by telephone (614) 692-0551 or DSN 850-0551.

DLA Land and Maritime drawing PIN <sup>1/</sup> 10018	Vendor similar designation or type number	Vendor CAGE	Vendor name and address
-01HTX	FMCE-1528-W/883	50821	Crane Electronics, Inc. 16706 13th Avenue West Lynnwood, WA 98037
-01HUX	FMCE-1528-V/883		
-01HXX	FMCE-1528/883		
-01HYX	FMCE-1528-Y/883		
-01HZX	FMCE-1528-Z/883		

<sup>1/</sup> Parts must be purchased to the DLA Land and Maritime CAGE CODE and PIN to assure that all performance requirements and tests are met.

<b>DEFENSE SUPPLY CENTER COLUMBUS, COLUMBUS, OHIO</b>	<b>SIZE A</b>	<b>CODE IDENT NO. 037Z3</b>	<b>DWG NO. 10018</b>
		<b>REV B</b>	<b>PAGE 11</b>