

PERFORMANCE SPECIFICATION

RESISTOR, FIXED, WIREWOUND (POWER TYPE),
NONESTABLISHED RELIABILITY, ESTABLISHED RELIABILITY, AND SPACE LEVEL
GENERAL SPECIFICATION FOR

This specification is approved for all Departments
and Agencies of the Department of Defense.

1. SCOPE

1.1 Scope. This specification covers the general requirements for nonestablished reliability (non-ER), established reliability (ER), or space level, axial lead precision, power type, wire wound, fixed resistors having a +25°C ambient operating temperature derated to zero load at +250°C for use in electrical, electronic communication, and associated equipment. These resistors have initial resistance tolerances of ±.5 percent, ±.1 percent, and ±1 percent, and a resistance temperature characteristic as given in [table I](#). ER resistors covered by this specification will have failure rates (FR) ranging from 1 percent to .001 percent per 1,000 hours (see [1.2.1.5](#)). These FR are established at 60 percent confidence on the basis of life tests (permissible resistance change of 1.0 percent). Resistors which are noninductively wound with solderable terminals are designated by a terminal designated "N" and "Z". Terminals designated by the letters "S" and "W" are inductively wound with solderable and weldable terminals (see [1.2.1.2](#)).

1.2 Classification.

1.2.1 Part or Identifying Number (PIN). The PIN is in the following format, and as specified (see [3.1](#) and [6.2](#)):

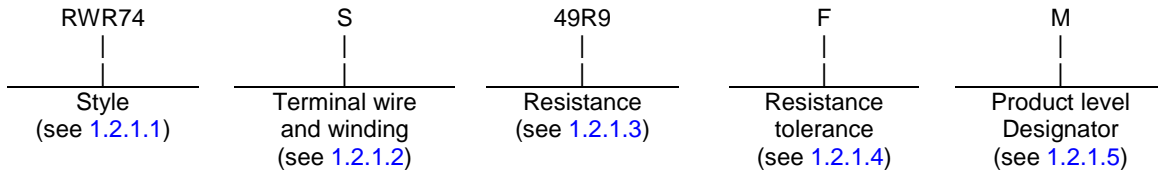

*

Comments, suggestions, or questions on this document should be emailed to usarmy.apg.cerdec.mbx.standardization-crx@mail.mil. Since contact information can change, you may want to verify the currency of this address information using the ASSIST Online database at <https://assist.dla.mil>.



MIL-PRF-39007J
w/ Amendment 3

1.2.1.1 Style. The style is to be identified by the three letter symbol "RWR" followed by a two digit number; the letters identify ER, axial-lead, power type, wire wound, fixed resistors, and the number identifies the sizes, wattage rating, and construction of the resistors.

1.2.1.1.1 Performance requirements. The performance requirements are identified in accordance with table I.

TABLE I. Performance requirements.

Style	RWR71 1/	RWR74 1/	RWR78	RWR80	RWR81	RWR84	RWR89	RWR82
Maximum resistance temperature characteristic in parts/million/°C-ppm (Reference to 25°C)	See 3.1	See 3.1	See 3.1	See 3.1	See 3.1	See 3.1	See 3.1	See 3.1
Maximum ambient temperature at rated wattage (see figure 1)	25°C	25°C	25°C	25°C	25°C	25°C	25°C	25°C
Maximum ambient temperature at zero wattage derating (see figure 1)	250°C	250°C	250°C	250°C	250°C	250°C	250°C	250°C
Power rating in watts	2	5	10	2	1	7	3	1.5
Maximum percent change in resistance ± 2/								
Conditioning (3.8)	.2	.2	.2	.2	.2	.2	.2	.2
Thermal shock (3.12)	.2	.2	.2	.2	.2	.2	.2	.2
Low temperature storage (3.14)	.1	.1	.1	.1	.1	.1	.1	.1
Short-time overload (3.15)	.2	.2	.2	.2	.2	.2	.2	.2
Dielectric withstanding voltage (3.16)	.1	.1	.1	.1	.1	.1	.1	.1
Moisture resistance (3.18)	.2	.2	.2	.2	.2	.2	.2	.2
Shock (specified pulse) (3.20)	.1	.1	.1	.1	.1	.1	.1	.1
Vibration high frequency (3.21)	.1	.1	.1	.1	.1	.1	.1	.1
Life (3.22)	See 3.22	See 3.22	See 3.22	See 3.22	See 3.22	See 3.22	See 3.22	See 3.22
High temperature exposure (3.23)	See 3.23	See 3.23	See 3.23	See 3.23	See 3.23	See 3.23	See 3.23	See 3.23
Insulation resistance (3.17)	1,000 megohms minimum	1,000 megohms minimum	1,000 megohms minimum	1,000 megohms minimum	1,000 megohms minimum	1,000 megohms minimum	1,000 megohms minimum	1,000 megohms minimum
Insulation resistance (3.18) (after moisture resistance)	100 megohms minimum	100 megohms minimum	100 megohms minimum	100 megohms minimum	100 megohms minimum	100 megohms minimum	100 megohms minimum	100 megohms minimum
Resistance tolerances ± percent	1, .5, .1	1, .5, .1	1, .5, .1	1, .5, .1	1, .5, .1	1, .5, .1	1, .5, .1	1, .5, .1

1/ Not for use on new design; for replacement purposes only.

2/ Where total resistance change is 1 percent or less, it is considered as ±(__ percent +0.005 ohm).

1.2.1.2 Terminal and winding. The terminal capability and inductive or noninductive winding designation are identified by a single letter in accordance with table II.

TABLE II. Terminal wire and winding.

Symbol	Terminal wire and winding
S	Solderable, inductively wound
W	Weldable, inductively wound
N	Solderable, noninductively wound <u>1/</u>
Z	Weldable, noninductively wound <u>1/</u>

1/ Wound using Ayrton-Perry method or a equivalent method.

1.2.1.3 Resistance. The nominal resistance is expressed in ohms and is identified by four digits; the first three digits represent significant figures and the last digit specifies the number of zeros to follow. When the value of resistance is less than 100 ohms, or when fractional values of an ohm are required, the letter "R" is substituted for one of the significant digits to represent the decimal point. When the letter "R" is used, succeeding digits of the group represent significant figures. The resistance value designations are shown in table III (for 1 percent tolerances) and [table VI](#) (for 0.1 percent and 0.5 percent tolerances). Minimum and maximum resistance values are as specified (see [3.1](#)). The standard resistance values for every decade follows the sequence demonstrated for 10 decade to 100 decade as specified in [table VI](#). For resistance tolerance F and tolerance D, only those resistance values which follow the sequence of values listed in the 10 decade to 100 decade specified in [table IV](#) are considered to be conforming to this specification.

TABLE III. Designation of resistance values.

Designation	Resistance (ohms)
R100 to R988 inclusive	.1 to 0.988 inclusive
1R00 to 9R88 inclusive	1 to 9.88 inclusive
10R0 to 98R8 inclusive	10 to 98.8 inclusive
1000 to 9880 inclusive	100 to 988 inclusive
1001 to 9881 inclusive	1,000 to 9,880 inclusive
1002 to 4022 inclusive	10,000 to 40,200 inclusive

MIL-PRF-39007J
w/ Amendment 3

TABLE IV. Standard resistance values for the 10 to 100 decade.

<u>1/</u> (B) 0.1 (D) 0.5	(F) 1.0	<u>1/</u> (B) 0.1 (D) 0.5	(F) 1.0	<u>1/</u> (B) 0.1 (D) 0.5	(F) 1.0	<u>1/</u> (B) 0.1 (D) 0.5	(F) 1.0
10.00	10.00	18.40		33.20	33.20	58.30	
10.10		18.70	18.70	33.60		59.00	59.00
10.20	10.20	18.90		34.00	34.00	59.70	
10.40		19.10	19.10	34.40		60.40	60.40
10.50	10.50	19.30		34.80	34.80	61.20	
10.60		19.60	19.60	35.20		61.90	61.90
10.70	10.70	19.80		35.70	35.70		
10.90		20.00	20.00			62.60	
11.00	11.00	20.30		36.10		63.40	63.40
11.10		20.50	20.50	36.50	36.50	64.20	
11.30	11.30	20.80		37.00		64.90	64.90
11.40		21.00	21.00	37.40	37.40	65.70	
11.50	11.50	21.30		37.90		66.50	66.50
11.70		21.50	21.50	38.30	38.30	67.30	
11.80	11.80	21.80		38.80			
12.00						68.10	68.10
12.10	12.10	22.10	22.10	39.20	39.20	69.00	
12.30		22.30		39.70		69.80	69.80
12.40	12.40	22.60	22.60	40.20	40.20	70.60	
12.60		22.90		40.70		71.50	71.50
12.70	12.70	23.20	23.20	41.20	41.20	72.30	
12.90		23.40		41.70		73.20	73.20
13.00	13.00	23.70	23.70	42.20	42.20	74.10	
13.20		24.00		42.70		75.00	75.00
13.30	13.30	24.30	24.30			75.90	
13.50		24.60		43.20	43.20	76.80	76.80
13.70	13.70	24.90	24.90	43.70		77.70	
13.80		25.20		44.20	44.20	78.70	78.70
14.00	14.00	25.50	25.50	44.80		79.60	
14.20		25.80		45.30	45.30	80.60	80.60
14.30	14.30	26.10	26.10	45.90		81.60	
14.50		26.40		46.40	46.40		
14.70	14.70	26.70	26.70	47.00		82.50	82.50
14.90				47.50	47.50	83.50	
15.00	15.00	27.10		48.10		84.50	84.50
15.20		27.40	27.40	48.70	48.70	85.60	
15.40	15.40	27.70		49.30		86.60	86.60
15.60		28.00	28.00	49.90	49.90	87.60	
15.80	15.80	28.40		50.50		88.70	88.70
16.00		28.70	28.70			89.80	
16.20	16.20	29.10		51.10	51.10	90.90	90.90
16.40		29.40	29.40	51.70			
16.50	16.50	29.80		52.30	52.30	92.00	
16.70				53.00		93.10	93.10
16.90	16.90	30.10	30.10	53.60	53.60	94.20	
17.20		30.50		54.20		95.30	95.30
17.40	17.40	30.90	30.90	54.90	54.90	96.50	
17.60		31.20		55.60		97.60	97.60
17.80	17.80	31.60	31.60			98.80	
18.00	18.00	32.00		56.20	56.20		
18.20	<u>2/</u> 18.20	32.40	32.40	56.90			
		32.80		57.60	57.60		

1/ The resistance values for tolerance B may be of any value but it is preferred that the values be chosen from the tolerance D values in this specification.

2/ Inactive for new design.

1.2.1.4 Resistance tolerance. The resistance tolerance is identified by a single letter in accordance with table V.

TABLE V. Resistance tolerance.

Symbol	Resistance tolerance percent (\pm)
B	0.1
D	0.5
F	1.0

1.2.1.4.1 Replacement or maintenance (applicable to 0.1 percent and 0.5 percent tolerances). It is preferred that resistance values be selected as specified in table IV. However, if it is impracticable to do so, then any values (within specification limits) may be specified and these values can be considered as conforming to this specification (see table VI and 3.1).

TABLE VI. Designation of resistance values (0.1 percent and 0.5 percent tolerances).

Designation	Resistance (ohms)
R100 to R999 inclusive	.1 to .9 inclusive
1R00 to 9R99 inclusive	1 to 9 inclusive
10R0 to 99R9 inclusive	10 to 99 inclusive
1000 to 9990 inclusive	100 to 999 inclusive
1001 to 9991 inclusive	1,000 to 9,999 inclusive
1002 to maximum	10,000 to maximum inclusive

1.2.1.5 Product level designator. The product level designators are specified in table VII, by a single letter which identifies non-ER, ER, or space level resistors.

TABLE VII. Product level designator.

Product level designation	Product level
C	Non-ER
M	$\frac{1}{1}$ 1.0
P	$\frac{1}{1}$ 0.1
R	$\frac{1}{1}$ 0.01
S	$\frac{1}{1}$ 0.001
T	Space level

$\frac{1}{1}$ FR in percent/1,000 hours.

2. APPLICABLE DOCUMENTS

2.1 General. The documents listed in this section are specified in sections 3 and 4 of this specification. This section does not include documents cited in other sections of this specification or recommended for additional information or as examples. While every effort has been made to ensure the completeness of this list, document users are cautioned that they must meet all specified requirements of documents cited in sections 3 and 4 of this specification, whether or not they are listed.

2.2 Government documents.

2.2.1 Specifications, standards, and handbooks. The following specifications, standards, and handbooks form a part of this document to the extent specified herein. Unless otherwise specified, the issues of these documents are those cited in the solicitation or contract.

DEPARTMENT OF DEFENSE SPECIFICATIONS

(See [supplement 1](#) for list of associated specifications.)

* DEPARTMENT OF DEFENSE STANDARDS

MIL-STD-202	-	Electronic and Electrical Component Parts, Test Methods for
MIL-STD-202-105	-	Test Method Standard Method 105, Barometric Pressure (Reduced)
MIL-STD-202-106	-	Test Method Standard Method 106, Moisture Resistance
MIL-STD-202-107	-	Test Method Standard Method 107, Thermal Shock
MIL-STD-202-108	-	Test Method Standard Method 108, Life (At Elevated Ambient Temperature)
MIL-STD-202-204	-	Test Method Standard Method 204, Vibration, High Frequency
MIL-STD-202-208	-	Test Method Standard Method 208, Solderability
MIL-STD-202-211	-	Test Method Standard Method 211, Terminal Strength
MIL-STD-202-213	-	Test Method Standard Method 213, Shock (Specified Pulse)
MIL-STD-202-215	-	Test Method Standard Method 215, Resistance to Solvents
MIL-STD-202-301	-	Test Method Standard Method 301, Dielectric Withstanding Voltage
MIL-STD-202-302	-	Test Method Standard Method 302, Insulation Resistance
MIL-STD-202-303	-	Test Method Standard Method 303, DC Resistance
MIL-STD-202-304	-	Test Method Standard Method 304, Resistance-Temperature Characteristic
MIL-STD-690	-	Failure Rate Sampling Plans and Procedures
MIL-STD-790	-	Standard Practice for Established Reliability and High Reliability Qualified Products List (QPL) Systems for Electrical, Electronic, and Fiber Optic Parts Specifications
MIL-STD-810	-	Environmental Test Methods and Engineering Guidelines
MIL-STD-1276	-	Leads for Electronic Component Parts
MIL-STD-1285	-	Marking of Electrical and Electronic Parts

(Copies of these documents are available online at <http://quicksearch.dla.mil/>.)

2.2.2 Other Government documents, drawings, and publications. The following other Government documents, drawings, and publications form a part of this document to the extent specified herein. Unless otherwise specified, the issues of these documents are those cited in the solicitation or contract.

NATIONAL AERONAUTICS AND SPACE ADMINISTRATION (NASA)

[NASA 1124](#) - Outgassing Data for Selecting Spacecraft Materials

(Copies of these documents are available online at <http://outgassing.nasa.gov/>.)

2.3 Non-Government publications. The following documents form a part of this document to the extent specified herein. Unless otherwise specified, the issues of these documents are those cited in the solicitation or contract.

AMERICAN SOCIETY FOR TESTING AND MATERIALS (ASTM)

[ASTM E595](#) - Materials from Outgassing in a Vacuum Environment, Total Mass Loss and Collected Volatile Condensable, Standard Test Method for

(Copies of these documents are available online at <http://www.astm.org/>.)

SAE INTERNATIONAL

- [SAE-EIA-554-1](#) - Assessment of Outgoing Nonconforming Levels in Parts Per Million (ppm).
- [SAE-EIA-557](#) - Statistical Process Control Systems

(Copies of these documents are available online at <http://www.sae.org>.)

2.4 Order of precedence. Unless otherwise noted herein or in the contract, in the event of a conflict between the text of this document and the references cited herein (except for related, specification sheets), the text of this document takes precedence. Nothing in this document, however, supersedes applicable laws and regulations unless a specific exemption has been obtained.

3. REQUIREMENTS.

3.1 Specification sheets. The individual item requirements shall be as specified herein and in accordance with the applicable specification sheet. In the event of any conflict between the requirements of this specification and the specification sheet, the latter shall govern.

3.2 Qualification. Resistors furnished under this specification shall be products that are authorized by the qualifying activity for listing on the applicable Qualified Products List (QPL), before contract award (see 4.4 and 6.3). In addition, the manufacturer shall obtain certification from the qualifying activity that the QPL system requirements of 3.3 and 4.2 have been met and are being maintained.

3.3 QPL system. The manufacturer shall establish and maintain a QPL system for parts covered by this specification. Requirements for this system are specified in MIL-STD-790 (all product levels) and MIL-STD-690 (ER parts only). The manufacturer shall also establish a Statistical Process Control (SPC), Part Per Million (PPM) and characterizing circuit reactance systems that meets the requirements as described in 3.3.1, 3.3.2 and 3.3.3 respectively.

3.3.1 SPC system. As part of the overall MIL-STD-790 QPL system, the manufacturer shall establish a SPC system that meets the requirements of SAE-EIA-557. Typical manufacturing processes for application of SPC include dc resistance values, cap/lead attachment, trimming, encapsulation, and weld strength. In addition, the manufacturer shall demonstrate resistance temperature characteristic (RTC) control in the process.

3.3.2 PPM system. As part of the overall MIL-STD-790 QPL system, the manufacturer shall establish a PPM system for assessing the average outgoing quality of lots in accordance with SAE-EIA-554-1 and 4.6.4. Data exclusion, in accordance with SAE-EIA-554-1, may be used with approval of the qualifying activity. The PPM system shall identify the PPM rate at the end of each month and shall be based on a six month moving average. PPM and dc resistance shall be assessed for each style. Style reporting may include both non-ER and ER style combinations. Due to low production volume, PPM assessment does not apply to space level lots.

3.3.3 Characterizing circuit reactance. As part of the overall MIL-STD-790 QPL system, the manufacturer shall establish a procedure for characterizing circuit reactance of the noninductively wound QPL parts (see 6.13 for suggested methods and application notes). The circuit reactance shall identify maximum effective series inductance and parallel capacitance, for all resistor styles and resistance values.

3.4 Material. A material shall be used which will enable the resistors to meet the performance requirements of this specification. Acceptance or approval of any constituent material shall not be construed as a guarantee of the acceptance of the finish product. In addition, for space level only, materials use in the manufacturing of the resistor shall meet the outgassing requirement (see 3.26).

3.5 Interface and physical dimension requirement. Resistors shall meet the interface and physical dimensions specified (see 3.1). The design of the resistors shall be such as to preclude shorting of turns and to obtain a minimum voltage drop between adjacent turns. Except as required for noninductive performance capability, resistors shall be wound with a single layer of resistance wire. For terminal wire and winding symbols "N" and "Z" resistors shall be wound by the Ayrtton-Perry method or an equivalent method.

3.5.1 Protective coating or enclosure. Resistor assemblies shall be protected by a coating of moisture resistant insulating material which shall completely cover the exterior of the resistance element, including connections or terminations. The coating shall not crack, craze, run, or form globules at any temperature up to including +250°C, regardless of the mounting position of the resistor. This material shall afford adequate protection against the effects of prolonged exposure to high humidities. The protective coating or enclosure shall be such as to minimize the establishment of leakage paths between the terminals resulting from collection of moisture film on the exterior surface of the resistor.

* 3.5.2 Terminals. Terminal shall be made of a solid conductor. The leads shall be solderable in accordance with MIL-STD-202-208 beyond the maximum specified clean-lead to clean-lead dimension.

3.5.2.1 Solderable terminals. Solderable leads shall be treated to meet the requirements of solderability (see 4.8.4). At the option of the manufacturer, the terminals may be solder coated or otherwise treated to meet solderability requirements following the conditioning test specified in 4.8.2. When a lead coating containing tin is used, the tin content shall range between 40 percent and 70 percent (see 3.1).

3.5.2.2 Weldable terminals. Weldable terminals shall be as specified in table II. The manufacturer shall verify by certification that the weldable terminals meet all the applicable requirements of MIL-STD-1276 (see 3.1). The solderability requirement of 3.10 is not applicable to weldable terminals.

3.5.2.3 Pure tin. The use of pure tin, as an underplate or final finish is prohibited both internally and externally. Tin content of resistor components and solder shall not exceed 97 percent, by mass. Tin shall be alloyed with a minimum of 3 percent lead, by mass (see 6.10.1).

3.5.3 Flux. Flux shall be of such a quality as to enable the resistors to meet all the requirements of this specification.

3.5.4 End caps (space level only). When end caps are used in construction of the resistor, the misalignment of the cap with respect to the core shall not exceed 5 degrees.

3.5.5 Insulation (space level only). Insulation materials surrounding the resistor body shall extend around the entire shoulder of each end cap toward the axis of the lead attachments and cover the internal resistive body.

3.5.6 Solder dip (retinning) leads. The manufacturer (or their authorized category B or C distributor) may solder dip/retin the leads of product supplied to this specification provided the solder dip process (see appendix A) has been approved by the qualifying activity.

3.5.7 Weight. Resistors shall not exceed the maximum weight specified (see 3.1).

3.6 Power rating. Resistors shall have a power rating based on continuous full load operation at an ambient temperature of +25°C (see 3.1). This power rating is dependent on the ability of resistors to meet the FR requirements specified in 3.22. For temperatures in excess of those specified above, the load shall be derated in accordance with figure 1.

3.7 Voltage rating. Resistors shall have a rated dc continuous working voltage or an approximate sine-wave root-mean-square (rms) continuous working voltage at commercial line frequency and waveform corresponding to the power rating, as determined from the following formula:

$$E = \sqrt{PR}$$

Where:

E = Continuous rated dc or rms working voltage in volts.
P = Rated wattage in watts (see 3.1).
R = Nominal resistance in ohms.

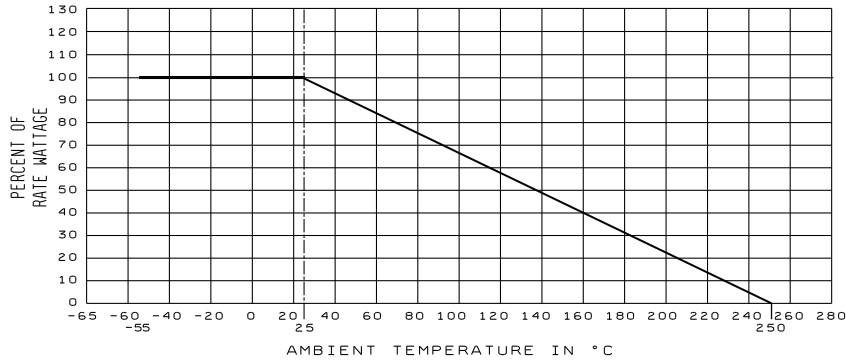

FIGURE 1. Derating curve for ambient temperatures.

3.8 Conditioning. When resistors are tested as specified in 4.8.2, there shall be no mechanical damage. The change in resistance shall not exceed \pm (0.2 percent +0.005 ohm).

3.9 DC resistance. When resistors are tested as specified in 4.8.3, the dc resistance shall be within the specified tolerance of the nominal resistance (see 1.2.1.4 and 3.1).

3.9.1 Resistance value deviations. All maximum deviations as specified in this section are to be considered absolute limits with the exception of the contact resistance adjustments.

3.10 Solderability (applicable to S and N terminals only). When resistors are tested as specified 4.8.4, they shall meet the criteria for wire lead terminal evaluation in the test method.

3.11 Resistance to solvents. When resistors are tested as specified in 4.8.5, there shall be no evidence of mechanical damage and marking shall remain legible.

3.12 Thermal shock. When resistors are tested as specified in 4.8.6, there shall be no evidence of mechanical damage; the change in resistance shall not exceed \pm (0.2 percent +0.005 ohm). For the 100 cycle qualification test for space level resistors, the change in resistance shall not exceed \pm (0.20 percent +0.005 ohm).

3.13 Resistance temperature characteristic. When resistors are tested as specified in 4.8.7, the resistance temperature characteristic between -55°C and +250°C shall not exceed values as specified in 3.1.

TABLE VIII. Resistance temperature characteristic.

DELETED

3.14 Low temperature storage. When resistors are tested as specified in 4.8.8, there shall be no evidence of mechanical damage. The change in resistance shall not exceed \pm (0.1 percent +0.005 ohm).

3.15 Short time overload. When resistors are tested as specified in 4.8.9, there shall be no evidence of arcing, burning, or charring; the change in resistance shall not exceed \pm (0.2 percent +0.005 ohm).

3.16 Dielectric withstanding voltage. When resistors are tested as specified in 4.8.10, the leakage rate shall not exceed 500 microamperes; there shall be no evidence of flashover, mechanical damage, arcing, or insulation breakdown; the change in resistance shall not exceed $\pm(0.1 \text{ percent} + 0.005 \text{ ohm})$.

3.17 Insulation resistance. When resistors are tested as specified in 4.8.11, the insulation resistance shall not be less than 1,000 megohms.

3.18 Moisture resistance. When resistors are tested as specified in 4.8.12, there shall be no evidence of mechanical damage; the change in resistance shall not exceed $\pm (0.2 \text{ percent} + 0.005 \text{ ohm})$. In addition, the dielectric withstanding voltage shall be as specified in 3.16, and the insulation resistance shall be 100 megohms, minimum.

3.19 Terminal strength. When resistors are tested as specified in 4.8.13, there shall be no evidence of breaking or loosening of terminals from the resistor form, or chipping of the coating on the leads is permissible as long as the end caps are not exposed. The change in resistance shall not exceed $\pm (0.1 \text{ percent} + 0.005 \text{ ohm})$.

3.20 Shock (specified pulse). When resistors are tested as specified in 4.8.14, there shall be no evidence of mechanical or electrical damage; the change in resistance shall not exceed $\pm (0.1 \text{ percent} + 0.005 \text{ ohm})$. There shall be no electrical discontinuity during the test.

3.21 Vibration, high frequency. When resistors are tested as specified in 4.8.15, there shall be no evidence of mechanical damage; the change in resistance shall not exceed $\pm (0.1 \text{ percent} + 0.005 \text{ ohm})$. There shall be no electrical discontinuity during the test.

3.22 Life. When resistors are tested as specified in 4.8.16, the change in resistance between the initial measurement and by any succeeding measurement shall not exceed the specified value for the application test period; there shall be no evidence of mechanical damage.

3.22.1 Qualification inspection. When resistors are tested as specified in 4.8.16, the change in resistance between the initial measurement and any succeeding measurement up to and including 2,000 hours +96 hours, -24 hours, shall not exceed $\pm(0.5 \text{ percent} + 0.005 \text{ ohm})$. The entire qualification sample shall be continued on test for 10,000 hours +120 hours, -0 hours.

3.22.2 FR determination (extend FR test). When resistors are tested as specified in 4.8.16, the change in resistance between the initial measurement up to and including 10,000 hours +120 hours, -0 hours shall not exceed $\pm(1.0 \text{ percent} + 0.005 \text{ ohm})$. This single failure criterion shall be applicable to all measurements during the life test for purposes of determining FR level qualification and is applicable as a parallel requirement with 3.22.1 to the measurement made during the life tests specified for qualification inspection.

3.23 High temperature exposure. When resistors are tested as specified in 4.8.17, there shall be no evidence of mechanical damage and the change in resistance shall not exceed $\pm 1 \text{ percent}$ for values above 100 ohms and $\pm(1 \text{ percent} + 0.005 \text{ ohm})$ for values 100 ohms and below.

3.24 Fungus. All external materials shall be nonnutrient to fungus growth or shall be treated to retard fungus growth. The manufacturer shall verify by certification that all external materials are fungus resistant or shall test the resistors as specified in 4.8.18. There shall be no evidence of fungus growth on the external surfaces.

3.25 Destructive physical analysis (DPA) (space level only). When examined as specified in 4.8.19 resistors shall meet the requirements in appendix B of this document.

3.26 Outgassing (space level only). When examined as specified in 4.8.20, the samples shall meet the following requirements:

- a. Total mass loss (TML) shall not exceed 1 percent.
- b. Volatile condensable material (VCM) shall not exceed .1 percent.

3.26.1 Outgassing test data. Data listed in [NASA 1124](#) may be used in lieu of actual test data for applicable materials. This information is available online at <http://outgassing.nasa.gov>. (See [2.2.2](#))

3.27 Radiographic inspection (space level only). When resistors are tested as specified in [4.8.21](#), they shall exhibit no evidence of defectives (see [figure C-2](#)). All testing shall be done in accordance with appendix C.

3.28 Marking. Resistors shall be marked with the PIN, "JAN" marking; date code, source code, and manufacturer's production lot code (see [MIL-STD-790](#)). Date and source code shall be in accordance with [MIL-STD-1285](#). At the option of the manufacturer, the PIN shall be divided between the characteristic letter and the first digit of the resistance value. The following is an example of complete marking:

12345 - Source code.
6633J - Date code, lot code, (any letter except "J") and "JAN" marking.
RWR47 - Style.
N1000 - Terminal-noninductive designator and resistance type designation.
FM - Tolerance and FR.

The date lot codes and lot symbols shall provide traceability through all production operations and shall represent a specific critical point consistently provided by the manufacturer. The common manufacturing record shall include the same date code as that on the parts covered by the record. Lot symbol shall be assigned in accordance with [MIL-STD-1285](#).

3.28.1 JAN and J marking. The United States Government has adopted, and is exercising legitimate control over the certification marks "JAN" and "J", respectively, to indicate that items so marked or identified are manufactured to, and meet all the requirements of specifications. Accordingly, items acquired to, and meeting all of the criteria specified herein and in applicable specifications shall bear the certification mark "JAN" except that items too small to bear the certification mark "JAN" shall bear the letter "J". The "JAN" or "J" shall be placed immediately before the part number except that if such location would place a hardship on the manufacturer in connection with such marking, the "JAN" or "J" may be located on the first line above or below the part number. Items furnished under contracts or orders which either permit or require deviation from the conditions or requirements specified herein or in applicable specification shall not bear "JAN" or "J". In the event an item fails to meet the requirements of this specification and the applicable specification sheets or associated specification, the manufacturer shall remove completely the military part number and the "JAN" or the "J" from the sample tested and also from all items represented by the sample. The "JAN" or "J" certification mark shall not be used on products acquired to contractor drawing or specifications. The United States Government has obtained Certificate of Registration Number 504,860 for the certification mark "JAN" and Registration Number 2,577,735 for the certification mark "J".

3.28.2 Minimum marking. When the physical size of the resistor style precludes the marking of all the above information, the minimum marking required shall be as specified in the associated detail specification (see [3.1](#)). Marking shall remain legible at the end of all tests. In those cases where full marking is not on the resistor body, the full marking shall be marked on the unit package.

3.28.3 Use of conductive inks. Conductive inks shall not be used to coat the body of the resistor as preparation for marking or used for marking resistors.

3.28.4 Beryllium oxide (BeO). Manufacturers which use beryllium oxide in their construction shall mark each resistor body and resistor package with the symbol "BeO".

3.29 Supplying to higher FR levels. A manufacturer may supply to all higher FR levels than to which they are qualified. Parts qualified and marked to lower FR levels are substitutable, with acquiring agency approval, for higher FR level parts, and shall not be remarked unless specified in the contract or order (see [table IX](#)) (see [6.2](#)).

TABLE IX. Product level substitution.

Product Level	Acceptable product level substitute
T (space)	
S (.001)	S
R (.01)	S, R
P (0.1)	S, R, P
M (1.0)	S, R, P, M
C (non-ER)	S, R, P, M

3.29.1 Supplying to higher resistance tolerances. Parts qualified and marked to lower tolerances, with acquiring agency approval, are substitutable for parts marked to higher tolerance levels and shall not be remarked unless specified in the contract or order (see 6.2 and table X).

TABLE X. Resistance tolerance substitution.

Resistance Tolerance	Resistance tolerance substitution
B	
D	B
F	B, D

3.30 Recycled, recovered, environmentally preferable, or biobased materials. Recycled, recovered, environmentally preferable or biobased materials should be used to the maximum extent possible, provided that the material meets or exceeds the operational and maintenance requirements, and promotes economically advantageous life cycle costs.

3.31 Soldering. Where soldering is employed, only noncorrosive fluxes shall be used, unless it can be shown that corrosive elements have been satisfactorily removed after soldering. Solder shall not be used for obtaining mechanical strength. Electrical connections shall be mechanically secure before soldering and electrically continuous after soldering. Except for solder used to coat the terminals, the solder used shall in no case start to melt at a temperature less than +300°C.

3.32 Workmanship. Resistors shall be processed in such a manner as to be uniform in quality and shall be free from other defects that will affect life, serviceability, or appearance.

4. VERIFICATION

4.1 Classification of inspection. The inspection requirements specified herein are classified as follows:

- a. Qualification inspection (see 4.4).
- b. Verification of qualification (see 4.5).
- c. Conformance inspection (see 4.6).
- d. Periodic group C inspection (see 4.7).

4.2 Reliability and quality.

4.2.1 QPL system. The manufacturer shall established and maintain a QPL system (see 3.3). Evidence of such compliance is a prerequisite for qualification and retention of qualification.

4.2.2 SPC. A SPC program shall be maintained in accordance with [SAE-EIA-557](#). Evidence of such compliance is a prerequisite for qualification and retention of qualification.

4.3 Inspection conditions and precautions.

4.3.1 Inspection conditions. Unless otherwise specified herein, all inspections shall be performed in accordance with the test conditions specified in the "GENERAL REQUIREMENTS" of [MIL-STD-202](#).

4.3.2 Precautions. Adequate precautions shall be taken during inspection to prevent condensation of moisture on resistors, except during moisture-resistance test.

4.4 Qualification inspection. Qualification inspection shall be performed at a laboratory acceptable to the Government (see [6.3](#)).

4.4.1 Samples. The samples shall be taken from a production run and shall be produced with equipment and procedures normally used in production. Each resistor style shall be qualified separately.

4.4.2 Test routine. Sample units shall be subjected to the qualification inspection specified in [table XI](#), in the order shown. All sample units, with the exception of those for group II and group VIII inspection, shall be subjected to the inspection of group IA. The 266 (or 296 for space level) sample units shall be divided as specified in [table XI](#) for group III, group IV, group VI, group VII, and group IX (group IX is space level only) and subjected to the inspection as applicable. In addition, four uncoated or unenclosed sample units shall be selected and subjected to group V inspection. An additional 10 sample units each shall be subjected to the first inspection of group II and nine of these same units shall be subjected to the second test of group II. An additional ten samples shall be subjected to the tests of group VIII. Additional samples for tolerance qualification shall be as specified in [A.3.2](#).

4.4.3 Defectives. Defectives in excess of those allowed in [table XI](#) shall be cause for refusal to grant qualification.

4.4.4 FR level and quality level verification (ER only).

4.4.4.1 FR qualification. FR qualification shall be in accordance with the general and detail requirements of [MIL-STD-690](#) and the following details:

- a. Procedure I: Qualification at the initial FR level. Level M (1.0 percent of FRSP-60) shall apply. Sample units shall be subjected to the qualification inspection specified in group VI of [table XI](#) (see [4.4.2](#)). Entire life test sample shall continue on test to 10,000 hours as specified in [4.8.16](#), upon completion of the 2,000 hour qualification.
- b. Procedure II: Extension of qualification to lower FR levels. To extend qualification to the R (0.01 percent) and S (0.001 percent) FR levels unit hours, two or more styles of similar construction may be combined. Style combinations shall be as described for lot formation (see [4.6.2](#)).
- c. Procedure III: Maintenance of FR level qualification. Maintenance period A of FRSP-10 shall apply. Regardless of the number of production lots produced during this period, the specified number of unit hours shall be accumulated to maintain qualification (see [4.7](#), periodic group C inspection).

MIL-PRF-39007J
w/ Amendment 3

TABLE XI. Qualification inspection.

Inspection	Requirement paragraph	Method paragraph	Number of sample units ^{1/}	Defects allowed ^{2/}
<u>Certification requirement (space level only)</u> Flux Outgassing	3.5.3 3.26	---- 4.8.20		
<u>Group I ^{3/}</u> Conditioning DC resistance	3.8 3.9	4.8.2 4.8.3	266	4/
<u>Group IA (coated or enclosed)</u> Visual and mechanical inspection ^{5/}	3.1, 3.4 through 3.5.7 inclusive, 3.28 to 3.32	4.8.1		
<u>Group II ^{6/}</u> Solderability (where applicable) (both leads) Resistance to solvents	3.10 3.11	4.8.4 4.8.5	9	1
<u>Group III</u> Thermal shock Resistance temperature characteristic Low temperature storage Short time overload Dielectric withstanding voltage Insulation resistance Moisture resistance Terminal strength	3.12 3.13 3.14 3.15 3.16 3.17 3.18 3.19	4.8.6 4.8.7 4.8.8 4.8.9 4.8.10 4.8.11 4.8.12 4.8.13	32 16 highest 16 lowest	
<u>Group IV</u> Thermal shock Shock, (specified pulse) Vibration, high frequency	3.12 3.20 3.21	4.8.6 4.8.14 4.8.15	30 15 highest 15 lowest	
<u>Group V (uncoated or unenclosed) ^{7/}</u> Visual and mechanical inspection	3.1, 3.4, 3.5, 3.28 to 3.32	4.8.1 as applicable	4 2 highest 2 lowest	
<u>Group VI</u> Life	3.22	4.8.16	102 51 highest 51 lowest	
<u>Group VII</u> High temperature exposure	3.23	4.8.17	102 51 highest 51 lowest	1
<u>Group VIII</u> Fungus	3.24	4.8.18	10	0
<u>Group IX (space level only)</u> Thermal shock (100 cycles)	3.12	4.8.6	15 lowest 30 15 highest	0

See footnotes on next page.

TABLE XI. Qualification inspection - Continued.

- 1/ See appendix A for details.
- 2/ Failure of a resistor in one or more tests of a group shall be charged as a single failure.
- 3/ Tests shall not be performed if a manufacturer presents certified data proving tests have been performed on the qualification sample.
- 4/ Item subjected to group IA through VIII inclusive, must meet requirements of group I.
- 5/ Marking shall be considered defective if illegible or missing. Marking shall remain legible at the end of all tests.
- 6/ Test may be performed on electrical rejects.
- 7/ Unenclosed sample units shall be subjected to visual and mechanical inspection as specified in group IA only.

* 4.5 Verification of qualification. Every 12 months, the manufacturer shall provide verification of qualification to the qualifying activity. Continued qualification is based on meeting the following requirements.

- a. MIL-STD-790 program.
- b. Design of resistor has not been modified.
- c. Lot rejection for group A (subgroup 1 and subgroup 3) does not exceed 5 percent or one lot, whichever is greater.
- d. Lot rejection for group B inspection does not exceed 5 percent or one lot, whichever is greater.
- e. Periodic group C inspection.
- f. FR levels.
- g. PPM assessment (NOTE: Grouping of style is permitted).
- h. Continued qualification to non-ER level (C) shall be based on continued maintenance of qualification for the ER part (minimum P FR level maintained).
- i. Continued qualification to the space level (T) shall be based on maintaining minimum ER FR level of S and maintenance of the test capability and lot control system for testing space level resistors.

4.6 Conformance inspection.

4.6.1 Inspection of product for delivery.

4.6.1.1 Non-ER resistors. The manufacturer's inspection system shall be used for preparation for delivery.

4.6.1.2 ER resistors. Inspection of product for delivery shall consist of group A and group B inspections. Group B inspection for preparation for is not required when the qualifying activity has allowed group B testing to be performed annually (see 4.6.5).

4.6.1.3 Space level. Inspection of product for delivery shall consist of all tests listed in group A and group B inspections and shall be performed on a production lot basis. Test deletion or reduction, which may be granted for ER level product, is not allowed for space level product.

4.6.2 Inspection and production lot.

4.6.2.1 Inspection lot. An inspection lot, as far as practical, shall consist of all the resistors of the same style, characteristic, protective enclosure or coating, and manufacturer under essentially the same process and conditions during a manufacturing period of 1 month maximum. For purposes of lot formation all terminal types may be included in the same lot; however, all lead types which are combined shall have the same method of terminal attachment. All leads in the lot shall be represented in a similar proportion by samples selected for inspection. Non-ER, ER, and space level lots shall be kept separate.

4.6.2.2 Production lot. A production lot shall consist of resistors of the same style, nominal resistance value, resistance tolerance, resistance temperature characteristic, and terminal type. Manufacture of all parts in the lot shall have been started, processed, assembled, and tested as a group. Lot identity shall be maintained throughout the manufacturing cycle. In addition for space level production lots only; the cores or encapsulation material for each lot shall be from the same raw materials lot. The raw materials used in the wire winding process shall be from the same raw material lots. Non-ER, ER, and space level lots shall be kept separate.

4.6.3 Group A inspection.

4.6.3.1 Non-ER resistors. The manufacturer shall establish and maintain an inspection system to verify that resistors meet dc resistance, visual/mechanical, and solderability requirements. In-line or process control may be part of such system. The inspection system shall also include criteria for lot rejection and corrective actions. The inspection system shall be verified under the overall MIL-STD-790 QPL system. NOTE: Since the non-ER (C level) is the ER design without the mandatory conformance inspection and FR level assessment, this product is still expected to meet the environmental qualification type requirements (e.g., moisture resistance, shock, vibration, etc.).

4.6.3.2 ER and space level resistors. Group A inspection shall consist of the inspections specified in table XII, in the order shown.

4.6.3.2.1 Subgroup 1. Subgroup 1 tests shall be performed on a production lot basis on 100 percent of the lot. Resistors that are out of resistance tolerance, or which experience a change in resistance greater than that permitted, shall be removed from the lot and not supplied to this specification. Only lots having not more than 5 percent rejects or one resistor, whichever is greater due to exceeding the specified resistance change limit, shall be furnished on contracts.

4.6.3.2.2 Subgroup 1A (space level only). Subgroup 1A tests shall be performed on a production lot on 100 percent of the product supplied under this specification. Resistors that are found not in compliance with the inspection criteria in appendix C shall be removed from the lot. Only lots having not more than 5 percent rejects or one resistor, whichever is greater due to noncompliance with the inspection criteria found in appendix C, as a result of subgroup 1A tests shall be furnished on contracts. Corrective action shall be taken on such rejects.

4.6.3.2.3 Manufacturer's production inspection. If the manufacturer performs tests similar to those specified in group A, subgroup 1, as the final step of his manufacturing process, the subgroup 1 tests may be eliminated when approved by the qualifying activity. The following criteria must be complied with:

- a. The production test is identical or more stringent than the subgroup 1 tests.
- b. 100 percent of the product supplied to these tests.
- c. Failure criteria are identical or more stringent than the subgroup 1 tests.
- d. Lot rejection criteria are identical or more stringent than the subgroup 1 tests.
- e. Once approved, future changes require approval from the qualifying activity.

4.6.3.2.4 Subgroup 2 tests. The subgroup 2 tests shall be performed on an inspection lot basis for ER parts and on a production lot basis for space level parts. A random sample of resistors shall be selected in accordance with table XIII. In the event of one or more failures, the lot is rejected. The rejected lot may be rescreened and the defects removed and resubmitted to the table XIII sample plan. If one or more defects are found in this second sample, the lot is rejected and shall not be supplied to this specification. (NOTE: This corrective action applies to the original quality defect found. If another defect type is found in the second sample, a rescreen for that defect is also permitted).

TABLE XII. Group A inspection (ER and space level only).

Inspection	Requirement paragraph	Test method paragraph	Sampling procedure
<u>Subgroup 1</u> <u>1/</u> Conditioning Thermal shock <u>2/</u> <u>3/</u> Short-time overload <u>2/</u> Dielectric withstanding voltage <u>2/</u> DC resistance <u>4/</u>	3.8 3.12 3.15 3.16 3.9	4.8.2 4.8.6 4.8.9 4.8.10 4.8.3	100 percent inspection
<u>Subgroup 1A</u> Radiographic <u>2/</u> <u>5/</u>	3.27	4.8.21	100 percent inspection, see 4.6.3.2.2
<u>Subgroup 2</u> Visual examination Terminals Marking <u>6/</u>	3.1, 3.4 to 3.5.7, 3.28 to 3.32 3.5.2 to 3.5.7 inclusive 3.28 through 3.28.4	4.8.1	See 4.6.3.2.4
<u>Subgroup 3</u> Solderability <u>7/</u>	3.10	4.8.4	See 4.6.3.2.5
<u>Subgroup 4</u> <u>2/</u> Destructive physical analysis	3.25	4.8.19	See 4.6.3.2.6

- 1/ At the manufacturer's option, the determination of resistance change may be by any method which is within the accuracy requirements of this specification.
- 2/ Space level only.
- 3/ If the manufacturer can demonstrate that the FR level of the parts can be maintained without performing the thermal shock screen, this test, with approval of the preparing activity and qualifying activity, may be deleted. If the design, material, construction, or processing of the part is changed, or if there are any quality problems or failures, the qualifying activity may require resumption of the test. As a minimum, for initial consideration of this option, the manufacturer shall demonstrate and validate using data equivalent to M FR qualification, that the test does not affect the FR of the resistor. Upon deletion of the test, the manufacturer must continue to maintain their existing FR level based on testing of parts without the thermal screening. (NOTE: Not applicable to space level product, test deletion or reduction is not allowed for space level product.)
- 4/ Resistors shall meet the specified initial resistance tolerance after being subjected to the preceding test. The resistance measurement made upon completion of the overload test may be used if a measurement has been made which can, with conversion, be directly related to nominal resistance value and tolerance.
- 5/ With the approval of the qualifying activity radiographic inspection can be conducted during production anytime after complete enclosure of the element.
- 6/ At the manufacturer's option, marking inspection may be performed after group B inspection; however, if this is done, no defects shall be permitted. Marking shall remain legible at the end of all tests.
- 7/ The manufacturer may request the deletion of the subgroup 3 solderability test, provided an in-line or process control system for assessing and assuring the solderability of leads can be validated and approved by the qualifying activity. Deletion of the test does not relieve the manufacturer from meeting this test requirement in case of dispute. If the design, material, construction, or processing of the part is changed or if there are any quality problems, the qualifying activity may require resumption of the test. (NOTE: Not applicable to space level product, test deletion or reduction is not allowed for space level product.)

TABLE XIII. Sampling plan for PPM categories.

Lot size	Sample size subgroup 2	Sample size PPM
1 - 13	100%	100%
14 - 125	13	100%
126 - 150	13	125
151 - 280	20	125
281 - 500	29	125
501 - 1,200	34	125
1,201 - 3,200	42	125
3,201 - 10,000	50	125
10,001 - 35,000	60	294
35,001 - 150,000	74	294
150,001 - 500,000	90	345
500,001 and over	102	435

4.6.3.2.5 Subgroup 3 (solderability). The subgroup 3 test shall be performed on an inspection lot basis for ER parts and on a production lot basis for space level parts. A sample shall be selected from each lot in accordance with table XIV. As an option, the manufacturer may use electrical rejects from the subgroup 1 tests for all or part of the sample. If there are one or more defects, the lot is rejected. The manufacturer may use one of the following options for corrective action:

- a. Each production lot that was used to form the failed inspection lot shall be individually submitted to the solderability test. Production lots that pass are available for shipment. Production lots that fail can be submitted to the solder dip procedure of [4.6.3.2.5b](#).

TABLE XIV. Solderability sample plan.

Lot size	Sample size
1 to 3,200	5
3,201 to 10,000	8
10,001 to 35,000	13
35,001 and over	20

- b. The failed lot is submitted to a 100 percent hot solder dip using an approved solder dip process in accordance with [3.5.6](#). A subsequent solderability test shall then be performed. If the lot passes, it is available for shipment; if the lot fails, the manufacturer may perform the hot solder dip one additional time. If the lot fails to pass, the lot is considered rejected and shall not be supplied to this specification.

4.6.3.2.5.1 Disposition of samples. The solderability test is considered a destructive test and samples submitted to the solderability test shall not be supplied on the contract.

4.6.3.2.6 Subgroup 4 (DPA) (space level only). The subgroup 4 test shall only be performed on space level inspection lots. A sample of five parts shall be selected from each lot and submitted to the test. If one or more defects are found, the lot is rejected and shall not be supplied to this specification. This test is destructive and the samples submitted to this test shall not be supplied on the contract.

4.6.4 PPM assessment (non-ER and ER). The manufacturer shall establish and maintain a system for assessing the average outgoing quality in PPM of lots supplied to this specification. This PPM assessment should be based on inspections performed on each inspection lot to verify that resistors meet dc resistance and tolerance requirements. For ER resistors, this inspection shall occur after the group A, subgroup 1, 100 percent screens have been completed.

4.6.4.1 Sampling plan. Minimum sample sizes for inspection lots shall be selected in accordance with [table XIII](#). For non-ER resistors, the sampling system and plan used for the group A inspection (see [4.6.3.1](#)) may be the basis for assessing PPM.

4.6.4.2 Rejected lots. Any rejected lot shall be segregated from new lots and those lots which have passed the PPM assessment. A rejected lot may be rescreened for the quality characteristic found defective in the sample and any defects removed. A new second sample shall be randomly selected. If one or more defects are found, this lot is rejected and shall not be supplied to the specification.

4.6.4.3 PPM calculations. PPM calculations shall be based on the accumulated results of the initial sample. Calculations and exclusions shall be in accordance with [SAE-EIA-554-1](#). (NOTE: PPM calculations shall not be based on the second sample submission for a rejected lot as described in [4.6.4.2](#)).

4.6.5 Group B inspection. Group B inspection shall consist of the examinations and tests specified in [table XV](#), in the order shown. ER parts shall be performed on inspection lots, and space level parts shall be performed on production lots that have been subjected to and have passed group A inspection.

4.6.5.1 Sampling plan (ER only). All qualified styles may be grouped together in a single sample. This can be accomplished by proportion based on manufacturing percentages by style, equally divided by style, or by establishing an alternating style sequence. In order to incorporate a style sampling grouping, a written description must be presented and approved by the qualifying activity. This plan must assure that the grouping only combines styles of the same basic design, encapsulation material, and the same element type. Style grouping is not permitted in cases where group B inspection is being performed on an annual basis.

4.6.5.2 Subgroup 1. A sample of 12 parts shall be randomly selected. If one or more defects are found, the lot shall be rescreened and defects removed. A new sample of 12 parts shall be randomly selected. If one or more defects are found in this second sample, the inspection lot shall be rejected and shall not be supplied to this specification.

4.6.5.3 Subgroup 2. A sample of 12 parts shall be randomly selected. If one or more defects are found, the lot shall be rescreened and defects removed. A new sample of 12 parts shall be randomly selected. If one or more defects are found in this second sample, the inspection lot shall be rejected and shall not be supplied to this specification.

4.6.5.4 Disposition of sample units. Sample units which have been subjected to group B, subgroup 1 inspections may be delivered on the acquisition document provided they are within resistance tolerance and meet requirements for visual and mechanical inspection. Sample units which have been subjected to subgroup 2 inspections shall not be supplied to this specification.

TABLE XV. Group B inspection (ER and space level only).

Inspection	Requirement paragraph	Test method paragraph	Sample size
<u>Subgroup 1</u> ^{1/} Visual and mechanical examination (when applicable)	3.1 and 3.28	4.8.1	12
<u>Subgroup 2</u> ^{2/} Resistance to solvents	3.11	4.8.5	12

^{1/} Only applicable when marking inspection is not performed in group A inspection.

No defects shall be permitted. Marking shall remain legible at the end of all tests.

^{2/} If the manufacturer can demonstrate that this test has been performed five consecutive times with zero failures, the frequency of this test, with the approval of the qualifying activity, can be performed on an annual basis. If the design, material, construction or processing of the part is changed, or if there are any quality problems or failures, the qualifying activity may require resumption of the original test frequency. (NOTE: Not applicable to space level product, test deletion or reduction is not allowed for space level product.)

4.7 Periodic Group C inspection (ER only). Periodic inspection shall consist of group C inspection tests specified in [table XVI](#), in the order shown. They shall be performed on sample units selected from lots that have passed group A and group B inspection. Except where the results of these inspections show noncompliance with the applicable requirements (see [4.7.7](#)), delivery of products which have passed group A and group B inspections shall not be delayed pending the results of these periodic inspections.

4.7.1 Sampling plan. If more than 1,000 resistors of any style or style grouping are produced over the maintenance period, the group C tests shall be performed as specified. If the production rate is less than 1,000 resistors for any style or style grouping over the maintenance period then the monthly, quarterly or semi-annual group C inspection may be postponed until at least 1,000 resistors of that style or style grouping are produced (except for the monthly life test). In any case, the monthly tests shall be performed at least once every 3 months. The quarterly tests shall be performed at least every 6 months and the semi-annual tests shall be performed at least once every year. This requirement is waived if the manufacturer has obtained a reduced inspection status through the qualifying activity.

All qualified styles may be grouped together in a single sample. This can be accomplished by proportion based on manufacturing percentages by style, equally divided by style, or by establishing an alternating style sequence. In order to incorporate a style sampling grouping, a written description must be presented and approved by the qualifying activity. This plan must assure that the grouping only combines styles of the same basic design, encapsulation material, and the same element type.

4.7.2.1 Monthly (subgroup 1). A minimum of five samples shall be selected from each inspection lot and placed on extended life test of [4.8.16](#) once a month for the full 10,000-hour life test. A sufficient number of samples shall be selected from each lot by the manufacturer so that the maintenance of the FR requirements are complied with; for each style separately for FR M and P, and for combined styles for FR R and S, within specified maintenance period. As far as practicable, the manufacturer shall select the resistance values so that the full range of all resistance decades produced during the maintenance period are represented.

4.7.2.2 Monthly (subgroup 2). Each month the specified number of sample units shall be subjected to the inspections of [table XVI](#). The samples shall be selected from a lot as defined in [4.6.2](#), and where possible shall be representative of the styles included in the lot. Over a 6-month period, the manufacturer should select samples so that a maximum variety of styles produced are tested. A separate set of samples shall be tested for each enclosure material each month.

4.7.3 Quarterly. Every 3 months, 10 sample units of each style and characteristic and of any resistance value shall be subjected to the tests specified in [table XVI](#), in the order shown.

4.7.4 Semiannually. Sample units and tests shall be as specified in [table XVI](#). The test sample should include all styles allowed to be combined for lot formation as practicable (see [4.6.2](#)). A complete separate sample shall be selected for each enclosure.

4.7.5 Annual. Sample units and test shall be as specified in [table XVI](#). The test sample shall include all styles allowed to be combined for lot formation (see [4.6.2](#)) as practicable. A complete separate sample shall be selected for each enclosure material.

MIL-PRF-39007J
w/ Amendment 3

TABLE XVI. Group C inspection. 1/

Inspection	Requirement paragraph	Test method paragraph	Number of sample	Number of defects allowed
<u>Monthly Subgroup 1</u> Life	3.22	4.8.16	See 4.7.2.1	See 4.7.2.1
<u>Monthly Subgroup 2</u> Resistance temperature characteristic 2/ Moisture resistance	3.13 3.18	4.8.7 4.8.12	10 6 highest 4 lowest	1
<u>Quarterly 3/</u> Dielectric withstanding voltage Insulation resistance Low temperature storage Terminal strength	3.16 3.17 3.14 3.19	4.8.10 4.8.11 4.8.8 4.8.13	10 5 highest 5 lowest	1
<u>Semiannually 3/</u> Short time overload Thermal shock Shock (specified pulse) Vibration, high frequency 4/	3.15 3.12 3.20 3.21	4.8.9 4.8.6 4.8.14 4.8.15	30 15 highest 15 lowest	1
<u>Annual</u> High temperature exposure	3.23	4.8.17	102 51 highest 51 lowest	1

1/ Marking shall remain legible at the end of all tests.

2/ If the manufacturer can demonstrate that this test has been performed for five consecutive times with zero failures, the frequency of this test, with the approval of the qualifying activity, can be performed on an annual basis. If the design, material, construction or processing of the part is changed, or if there are any quality problems or failures, the qualifying activity may require resumption of the original test frequency.

3/ If the manufacturer can demonstrate that these tests have been performed for five consecutive times with zero failures, these tests, with the approval of the quality activity, can be deleted. The manufacturer, however, shall perform these tests every three years after the deletion as part of long term design verification. If the design, material, construction or processing of the part is changed, or if there are any problems, the qualifying activity may require resumption of the specified testing. Deletion of testing does not relieve the manufacturer from meeting the test requirement in case of dispute.

4/ Ten samples of values representative of production in that period.

4.7.6 Disposition of samples. Sample units which have been subjected to group C inspection shall not be delivered on the contract.

4.7.7 Noncompliance. If a sample fails to pass group C inspection, the manufacturer shall immediately notify the qualifying activity and the cognizant inspection activity of such failure and take corrective action on the materials or processes, or both, as warranted, and on all units of products which can be corrected and which are considered subject to the same failure. For ER and space level parts, acceptance and shipment of the product shall be discontinued until corrective action, acceptable to the qualifying activity, has been taken. For C level parts, stop shipment may not be necessary depending on the nature of the failure. After the corrective action has been taken, group C inspection shall be repeated on additional sample units (all inspections, or the inspection which the original sample failed, at the option of the qualifying activity). Group A and group B inspection may be reinstated; however, final acceptance and shipment shall be withheld until the group C inspection has shown that the corrective action was successful.

4.8 Methods of inspections.

4.8.1 Visual and mechanical inspection. Resistors shall be inspected to verify that the materials, design, construction, physical dimensions, and workmanship are in accordance with the acceptable requirements. For space level product (T) only, visual inspection shall be performed at 20X (see 3.1, 3.4 through 3.5.7, 3.28 to 3.32).

- * 4.8.2 Conditioning (see 3.8). Resistors shall be conditioned in accordance with MIL-STD-202-108. The following details and exceptions shall apply:
- a. Method of mounting: Supported by their terminal leads at point .375 inch \pm .062 inch from the resistor body. Resistors shall be so arranged that the temperature of any one resistor shall not appreciably influence the temperature of any other resistor. There shall be no undue draft on the resistors. If forced-air circulation is employed, the air velocity shall not exceed 500 feet per minute and there shall be no direct impingement of the forced-air supply upon the resistors.
 - b. Test temperature and tolerance: +25°C, +15°C, -0°C.
 - c. Initial measurements: Initial resistance shall be measured as specified in 4.8.3 at +25°C +15°C, -0°C. This initial measurement shall be used as the reference for all subsequent measurements.
 - d. Operating conditions: Rated dc continuous working voltage or rated working voltage from an alternating current (ac) power supply at commercial line frequency, intermittently, 1 hour 30 minutes "on" and 30 minutes hour "off" for 100 hours +16 hours, -4 hours. Where the resulting wave form is other than that of a commercial line, voltage shall be set using a "true rms" voltmeter and the peak voltage shall not exceed 2.5 times the rated continuous working voltage. Each resistor shall dissipate a wattage equal of the resistor.
 - e. Measurement after condition: Resistance shall be measured at the end of 100 hours +16 hours, -4 hours as specified in 4.8.2c and 4.8.3. The same procedure for measurement shall be used for initial and final measurements. Leads may be cleaned prior to final measurement.
 - f. Examination after conditioning: Resistors shall be examined for evidence of mechanical damage.
- * 4.8.3 DC resistance (see 3.9). Resistors shall be tested in accordance with MIL-STD-202-303. The following details and exceptions shall apply:
- a. Measuring apparatus: Different types of measuring test equipment (multimeters, bridges, or equivalent) are permitted to be used on the initial and final readings of this test, provided the equipment is the same style, model, or if it can be shown that the performance of the equipment is equivalent or better.
 - b. Limit of error of measuring apparatus: One fourth of the specified initial resistance tolerance or 0.1 percent, whichever is less, +0.002 ohm. The same measuring apparatus shall be used for any one test, but not necessarily for all tests.
 - c. Test voltage: Measurements of resistance shall be made using a dc potential resulting in not more than 1 percent of rated wattage. This same voltage shall be used whenever a subsequent resistance measurement is made. For values less than 10 ohms, use a measuring device limited to 100 milliamperes or less.
 - d. Measurement energy for electronic test equipment: The measurement energy applied to the unit under test shall not exceed 10 percent of the 25°C rated wattage times 1 second.
 - e. Points of application of test voltage for initial resistance tolerance measurement: Resistors shall be measured by attaching the test leads as close to the resistor body as practical. For resistors 20 ohms and less, the referee point for attaching the test leads shall be .375 inch \pm .062 inch from the body.

- * 4.8.4 Solderability (applicable to S and N terminals only) (see 3.10). Resistors shall be tested in accordance with MIL-STD-202-208. The following details shall apply:
 - a. Both leads shall be tested.
 - b. The leads shall be dipped within .062 inch of the body.
- * 4.8.5 Resistance to solvents (see 3.11). Resistors shall be tested in accordance with MIL-STD-202-215. The following details shall apply:
 - a. The marked portion of the resistor body shall be brushed.
 - b. The number of sample units shall be as specified in table XI or table XV, as applicable.
 - c. Resistors shall be examined for mechanical damage and legibility of markings.
- * 4.8.6 Thermal shock (see 3.12). Resistors shall be tested in accordance with MIL-STD-202-107. The following details and exception shall apply:
 - a. Mounting: Resistors shall be mounted by means other than soldering or may be placed in trays. When trays are used, they must be designed to present a minimum obstruction to the airstream. In no case shall the fixture prevent the specified ambient temperature from being achieved with 4 minutes after resistors are placed in chamber. One chamber may be used for this test.
 - b. Measurement before cycling: DC resistance shall be measured as specified in 4.8.3.
 - c. Test condition B.
 - d. Measurement after cycling: Not less than 1 hour, but within a 24-hour period after the last cycle, dc resistance shall be measured as specified in 4.8.3.
 - e. Examination after test: Resistors shall be examined for evidence of mechanical damage.
- * 4.8.7 Resistance temperature characteristic (see 3.13). Resistors shall be tested in accordance with MIL-STD-202-304. The test temperature shall be in accordance with table XVII.

ABLE XVII. Resistance temperature characteristic.

Sequence	Temperature	
	Qualification inspection	Group C inspection
	°C ±3°C	°C ±3°C
1	<u>1/</u> 25	<u>1/</u> 25
2	-15	
3	-55	
4	<u>1/</u> 25	<u>1/</u> 25
5	125	125
6	200	
7	250	250

1/ This temperature shall be considered the reference temperature for each of the succeeding temperatures.

NOTE: At the option of the manufacturer, the reverse sequence of table XVII may be as follows:

1. 25 ±3°C.
2. +125 ±3°C.
3. +250 ±3°C.
4. 25 ±3°C.
5. -55 ±3°C.

4.8.8 Low temperature storage (see 3.14).

4.8.8.1 Mounting. Resistors shall be mounted by means other than soldering or may be placed in trays. When trays are used, they must be designed to present a minimum obstruction to the airstream. In no case shall the fixture prevent the specified ambient temperature from being achieved within 4 minutes after resistors are placed in chamber. One chamber may be used for this test.

4.8.8.2 Procedure. DC resistance shall be measured as specified in 4.8.3. Within 1 hour after this measurement, the resistors shall be placed in a cold chamber at a temperature of $-55^{\circ}\text{C} \pm 2^{\circ}\text{C}$ for a period of 24 hours ± 4 hours. The resistors shall then be removed from the chamber and maintained at a temperature of $+25^{\circ}\text{C} \pm 5^{\circ}\text{C}$ for a period of approximately 2 hours to 8 hours; the dc resistance shall again be measured as specified in 4.8.3. Resistors shall then be examined for evidence of mechanical damage.

4.8.9 Short time overload (see 3.15). DC resistance shall be measured as specified in 4.8.3. The resistors shall then be mounted by means other than soldering and shall be subjected to an overload voltage which will result in the specified multiple of rated wattage for 5-second duration (see 3.1). DC resistance shall again be measured after the resistors have cooled to room temperature.

4.8.10 Dielectric withstanding voltage (3.16).

* 4.8.10.1 Atmospheric pressure. Resistors shall be tested in accordance with MIL-STD-202-301. The following details and exceptions shall apply:

- a. Special preparations: Resistors shall be placed in a conductive material which will conform to the resistor surface so that between 90 to 100 percent of the outer periphery is contacted. The conductive material shall be centered on the resistor body. Care should be taken that any part of the resistor lead is as far away from the conductive material as possible.
- b. Initial measurement: DC resistance shall be measured as specified in 4.8.3. Not applicable for group A inspection.
- c. Magnitude of test voltage: As specified (see 3.1).
- d. Nature of potential: An ac supply at commercial line frequency and waveform.
- e. Duration of application of test voltage:
 - (1) Five seconds for group A inspection.
 - (2) One minute for qualification and group C inspection.
- f. Rate of application of voltage: The test voltage shall be raised from zero to the application value, as uniformly as practicable, at the following rates:
 - (1) 500 volts rms per second for group A testing.
 - (2) 100 volts rms per second for group C and qualification testing.
- g. Points of application of test voltage: Between the resistor terminals connected together and mounting hardware, or the conductive material, as applicable.
- h. Measurement during the test: The leakage current shall be monitored during the application of test voltage.
- i. Measurement after test (not applicable to group A testing): DC resistance shall be measured as specified in 4.8.3.
- j. Examinations after test: Resistors shall be examined for evidence of flashover, mechanical damage, arcing, and insulation breakdown.

- * 4.8.10.2 Barometric pressure (reduced). Resistors shall be tested in accordance with [MIL-STD-202-105](#). The following details and exceptions shall apply: (Applicable to qualification and group C inspection only.)
 - a. Method of mounting: As specified in [4.8.10.1a](#).
 - b. Initial measurement: DC resistance shall be measured as specified in [4.8.3](#).
 - c. Test condition D (100,000 feet).
 - d. Test voltage during subjection to reduced pressure: As specified (see [3.1](#)).
 - e. Nature of potential: As specified in [4.8.10.1d](#).
 - f. Duration of test: One minute.
 - g. Points of application of test voltage: As specified in [4.8.10.1g](#).
 - h. Final measurement: DC resistance shall be measured as specified in [4.8.3](#).
 - i. Examinations after test: As specified in [4.8.10.1i](#).
- * 4.8.11 Insulation resistance (see [3.17](#)). Resistors shall be tested in accordance with [MIL-STD-202-302](#). The following details shall apply:
 - a. Test condition A.
 - b. Special preparation: As specified in [4.8.10.1a](#).
 - c. Points of measurement: As specified in [4.8.10.1g](#).
- * 4.8.12 Moisture resistance (see [3.18](#)). Resistors shall be tested in accordance with [MIL-STD-202-106](#). The following details and exceptions shall apply:
 - a. Mounting: Soldered by the leads to rigid mounts or terminal lugs. The spacing of the mounts or terminal lugs shall be such that the length of each resistor lead is approximately .375 inch when measured from the edge of the supporting terminal to the resistor body. One half of the sample units shall be covered with a V shaped metal strap whose width is equal to the length of the resistor body as indicated on [figure 2](#). The strap shall be made of a corrosion resistant metal and shall be kept in contact with the resistor body by supporting the body as indicted on figure 2, with a conducting, noncorrosive support whose width is less than that of the body and which will not act as a moisture trap. For group C inspection, each half of the sample shall be apportioned as three highest values, two lowest values for a total of five sample units per half. The mounting straps may be individual for each resistor or continuous for all resistors.
 - b. Initial measurement: Immediately following the initial conditioning period, dc resistance shall be measured as specified in [4.8.3](#) at test conditions specified in [4.3.1](#).
 - c. Polarization and loading voltage:
 - (1) Polarization voltage: During steps 1 to 6 inclusive, a 100 volt dc potential shall be applied only to those resistors which have a polarization strap. This potential shall be applied with the positive lead connected to the resistor terminals tied together, and the negative lead connected to the polarization straps.
 - (2) Loading voltage: During the first 2 hours of steps 1 and 4, a dc test potential equivalent to 100-percent rated wattage shall be applied to those resistors which do not have the polarizing strap specified in [4.8.12a](#).

- d. Subcycle: Step 7b shall not be applicable. Step 7a shall be performed during any five of the first nine cycles only.
- e. Final measurements: Upon completion of step 6 of the final cycle, the resistors shall be held at the high humidity condition and a temperature of $+25^{\circ}\text{C} \pm 2^{\circ}\text{C}$ for a period of 1 hour and 30 minutes to 3 hours and 30 minutes. Resistors shall then be removed from the chamber, and within 8 hours, the dielectric withstanding voltage (atmospheric), insulation resistance, and dc resistance tests shall be performed as specified in 4.8.10.1, 4.8.11, and 4.8.3, respectively. The same straps used for polarizing the resistors may also be used for the dielectric withstanding voltage and insulation resistance tests.
- f. Examination after test: Resistors shall be examined for evidence of mechanical damage.

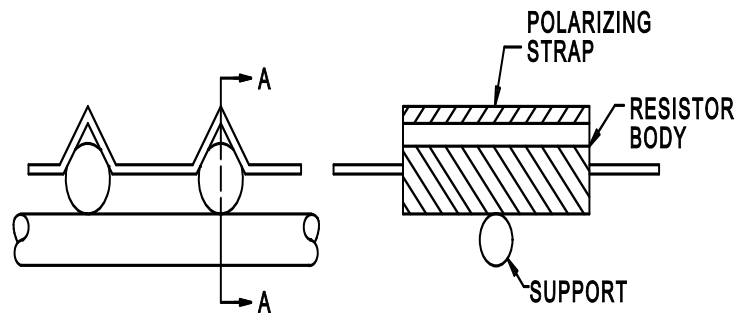

FIGURE 2. Mounting straps for moisture resistance test.

- * 4.8.13 Terminal strength (see 3.19). Tests shall be in accordance with MIL-STD-202-211 with the following exceptions:
 - a. Test condition A and condition D. (Pull test and twist test, respectively.)
 - b. Measurement before test (condition A): DC resistance as specified in 4.8.3.
 - c. Method of holding (condition A): Resistors shall be clamped by one terminal lead.
 - d. Applied force (condition A): As specified (see 3.1).
 - e. Measurement after test (condition D): DC resistance as specified in 4.8.3 and examined for evidence of breaking and loosening of terminals and chipping of coating.

- * 4.8.14 Shock (specified pulse) (see 3.20). Resistors shall be tested in accordance with MIL-STD-202-213. The following details and exceptions shall apply:
- a. Special mounting means: Resistors shall be rigidly mounted on appropriate jig fixtures with their leads supported at a distance of .375 inch \pm .062 inch from the resistor body. These fixtures shall be constructed in a manner to ensure that the points of the resistor mounting supports will have the same motion as the shock table. The leads used during this test shall be no larger than AWG size 22 stranded wire, so that the influence of the test lead on the resistor will be held to a minimum. The test lead length shall be no longer than necessary. In all cases, the resistors shall be mounted in relation to the test equipment in such a manner that the stress applied is in the direction which would be considered most detrimental.
 - b. Measurement before shock: DC resistance shall be measured as specified in 4.8.3.
 - c. Test condition I.
 - d. Number and direction of applied shocks: The resistors shall be subjected to a total of ten shocks in each of two mutually perpendicular planes, one perpendicular and the other parallel to the longitudinal axis of the resistor.
 - e. Measurement during shock: DC resistance shall be measured as specified in 4.8.3.
 - f. Measurement after shock: DC resistance shall be measured as specified in 4.8.3.
 - g. Examination after test: Resistors shall be examined for evidence of mechanical and electrical damage.
- * 4.8.15 Vibration, high frequency (see 3.21). Resistors shall be tested in accordance with MIL-STD-202-204. The following details and exceptions shall apply:
- a. Mounting specimens: Resistors shall be mounted on appropriate jig fixtures with their bodies restrained from movement and their leads supported at a distance of .375 inch \pm .062 inch from the resistor body. The fixtures shall be constructed in a manner to ensure that the points of the resistor mounting supports will have the same motion as the vibration test table. The fixtures shall also be of a construction that will preclude any resonance in the fixture when subjected to vibration within the test frequency range, and the fixture shall be monitored for these features on the vibration table. Test leads used during this test shall be no larger than AWG size 22 stranded wire, so that the influence of the test lead on the resistor will be held to a minimum. The test lead length shall be no greater than is absolutely necessary. A shielded cable, which may be necessary because of the field surrounding the vibration table, shall be clamped to the resistor mounting jig.
 - b. Initial measurement: DC resistance shall be measured as specified in 4.8.3.
 - c. Test condition D.
 - d. Direction of motion: In each of two mutually perpendicular directions, one perpendicular and the other parallel to the longitudinal axis of the resistor. Total test time shall be 6 hours in each direction for a total of 12 hours.
 - e. Measurement during test: Each resistor shall monitor to determine electrical discontinuity by a method which shall at least be sensitive enough to monitor or register, automatically, any electrical discontinuity of 0.1 millisecond or greater duration.
 - f. Measurement after vibration: DC resistance shall be measured as specified in 4.8.3.
 - g. Examination after test: Resistors shall be examined for evidence of mechanical damage.

- * 4.8.16 Life (see 3.22). Resistors shall be tested in accordance with [MIL-STD-202-108](#). The following details and exceptions shall apply:
- a. Method of mounting: Resistors shall be mounted on lightweight terminals. The integrity of the terminations shall be determined at each measurement interval. The voltage applied to any resistor shall not be less than 95 percent of the dc, ac line or true rms rate continuous working voltage. Resistors shall be arranged so that the temperature of any one resistor shall not appreciably influence the temperature of any other resistor. If force air circulation is employed, the air velocity shall not exceed 500-feet per minute, and there shall be no direct impingement of the forced air supply on the resistors.
 - b. Test temperature: $+25^{\circ}\text{C} \pm 5^{\circ}\text{C}$.
 - c. Initial measurements: Initial resistance shall be measured after mounting at $+25^{\circ}\text{C} \pm 5^{\circ}\text{C}$. This initial measurement shall be used as the reference temperature for all measurements.
 - d. Operating conditions: Resistors shall be operated at full rated wattage by applying dc continuous working voltage, or ac rated continuous working voltage, from an ac supply at commercial line frequency, intermittently, 1 hour and 30 minutes "on" and 30 minutes "off" for the applicable number of hours (see [4.8.16f](#)). "On time" shall be .750 of the total elapsed time. The actual test time shall be recorded. Where the resulting waveform is other than that of a commercial line, voltages shall be set using a "true rms" voltmeter, and the peak voltage shall not exceed 2.5 times the rated continuous working voltage.
 - e. Test condition: 2,000 hours for qualification inspection with all samples continued on test to 10,000 hours. Ten thousand hours for FR level determination of group C.
 - f. Measurements during test:
 - (1) Qualification inspection: Resistance (see [4.8.3](#)) shall be measured at the end of the 30 minutes "off" periods after 250 hours +72 hours, -24 hours, 500 hours +72 hours, -24 hours, 1,000 hours +72 hours, -24 hours, and 2,000 hours +96 hours, -24 hours have elapsed. Units continued on test shall be measured at intervals above 2,000 hours +96 hours, -24 hours in accordance with [4.8.16f \(2\)](#).
 - (2) Extended life testing: Resistance (see [4.8.3](#)) shall be measured at the end of the 30 minutes "off" periods after 250 hours +72 hours, -24 hours, 500 hours +72 hours, -24 hours, 1,000 hours +72 hours, -24 hours, 2,000 hours +96 hours, -24 hours and every 2,000 hours +96 hours, -24 hours thereafter, until the required extended life period (10,000 hours +120 hours, -0 hours) has elapsed. Measurements shall be made as near as possible to the specified time but may be adjusted so that measurements need not be made during other than normal working days.
 - g. Examination after test: Resistors shall be examined for evidence of mechanical damage.
- 4.8.17 High temperature exposure (see 3.23).
- a. Mounting: Resistors shall be mounted by means other than soldering or may be placed in trays. When trays are used, they must be designed to present a minimum obstruction to the airstream. In no case shall the fixture prevent the specified ambient temperature from being achieved within 4 minutes after resistors are placed in chamber. One chamber may be used for this test.
 - b. Initial measurement: DC resistance shall be measured as specified in [4.8.3](#) at room ambient conditions.
 - c. Procedure: Following initial resistance measurements, resistors shall be placed in a chamber maintained at $250^{\circ}\text{C} \pm 7^{\circ}\text{C}$ for a period of 2,000 hours +72 hours, -24 hours with no load applied.

- d. Measurement during test: At 250 hours +72 hours, -24 hours, resistors shall be removed from the chamber and permitted to stabilize at room temperature and within 6 hours after removal, the dc resistance shall be measured as specified in 4.8.3. Resistors shall be examined for evidence of mechanical damage.
- e. Final measurements: After removal from the test chamber, resistors shall be permitted to stabilize at room ambient temperature and within 6 hours after removal, cleaning of the leads will be allowed and the dc resistance shall be measured as specified in 4.8.3. Resistors shall be examined for evidence of mechanical damage.

4.8.18 Fungus (see 3.24). Resistors shall be tested in accordance with method 508 of MIL-STD-810. Resistors shall be examined for evidence of mechanical damage.

4.8.19 DPA (space level only) (see 3.25). Resistors shall be examined as specified in appendix B of this document.

4.8.20 Outgassing (space level only) (see 3.26). The resistors organic materials shall be tested in accordance with ASTM E595.

4.8.21 Radiographic inspection (space level only) (see 3.27). In accordance with appendix C; two views 90 degrees apart by X-ray, or 360 degrees view by Vidicon. Use of "real time" X-ray system capable of viewing through 360 degrees of rotation is encouraged.

5. PACKAGING

5.1 Packaging. For acquisition purposes, the packaging requirements shall be as specified in the contract or order (see 6.2). When packaging of material is to be performed by DoD or in-house contractor personnel, these personnel need to contact the responsible packaging activity to ascertain packaging requirements. Packaging requirements are maintained by the Inventory Control Point's packaging activities within the Military Service or Defense Agency, or within the military service's system commands. Packaging data retrieval is available from the managing Military Department's or Defense Agency's automated packaging files, CD-ROM products, or by contacting the responsible packaging activity.

6. NOTES

(This section contains information of a general or explanatory nature which may be helpful, but is not mandatory).

6.1 Intended use. Resistors described herein are intended to be used in electrical, electronic communication, and associated equipment.

6.2 Acquisition requirements. Acquisition documents must specify the following:

- a. Title, number, and date of this specification, the applicable associated specification, and the complete PIN (see 1.2.1).
- b. Unless otherwise specified (see 2.1), the versions of the individual documents referenced will be those in effect on the date of release of the solicitation.
- c. Packaging requirements (see 5.1).
- d. Allowable substitution (see 3.29 and 3.29.1).

* 6.3 Qualification. With respect to products requiring qualification, awards will be made only for products which are, at the time of award of contract, qualified for inclusion in Qualified Product List [QPL-39007](#) whether or not such products have actually been so listed by that date. The attention of the contractors is called to these requirements, and manufacturers are urged to arrange to have the products that they propose to offer to the Federal Government tested for qualification in order that they may be eligible to be awarded contracts or orders for the products covered by this specification. The activity responsible for the QPL is the US Army Communications - Electronics Research Development and Engineering Center (CERDEC), ATTN: RDER-PRO, Aberdeen Proving Ground, Bldg. 6010 K-130, MD 21005; however, information pertaining to qualification of products may be obtained from DLA Land and Maritime, ATTN: VQP, P.O. Box 3990, Columbus, OH 43218-3990 or by email to vqp.chief@dla.mil. An online listing of products qualified to this specification may be found in the Qualified Products Database (QPD) at <https://assist.dla.mil>.

6.4 Derating. The intention of this specification is to cover resistors capable of full load operation with a high degree of stability at any ambient temperature up to and including +25°C. However, if it is desired to operate these resistors at ambient temperatures greater than +25°C, the resistors should be derated in accordance with [figure 1](#).

6.5 Mounting. Under conditions of severe shock or vibration, or a combination of both, resistors of all sizes described in this specification should be mounted so that the body of the resistor is restrained from movement with respect to the mounting base. It should be noted that if clamps are used, certain electrical characteristics of the resistors will be altered. The heat clamping material is a good or poor heat conductor. Under less severe vibration conditions, all styles may be supported by their leads only. The lead lengths should be kept as short as possible, .250 inch or less is preferred, but not longer than .625 inch. The longer the lead is the more likely that a mechanical failure will occur.

6.5.1 RWR80 series mounting. When RWR80 series resistors are to be used at full rated wattage, the maximum lead length should be .500 inch from the resistor body to the mounting surface.

6.6 High frequency. Resistors should not be used in circuits where their ac performance is of critical importance in operation of such circuits.

6.7 Coating materials. Certain coating materials used in fabricating resistors to this specification may be subject to "outgassing" of volatile material when operated at surface temperatures over +200°C. These phenomena should be taken into consideration for equipment design.

6.8 Selection and use information. Equipment designers should refer to [MIL-HDBK-199](#), "Resistors, Selection and Use of", for a selection of standard resistor types and values for any new equipment design. All applications and use information concerning these resistors are provided in MIL-HDBK-199, and in [table I](#) within.

6.9 Thermal conductivity and cost (RWR80 series). The RWR80 series of resistors are constructed with cores of higher thermal conducting material than the RWR70 series; as a result, the RWR80 series of resistors are higher in power ratings and cost in respect to the equivalent RWR70 series of resistors.

6.10 Maintenance and replacement of lead types. For maintenance and replacement or other logistical purposes, solderable leads (S) should be used to support weldable leads (W). Weldable leads should not be stocked.

6.10.1 Tin whisker growth. The use of alloys with tin content greater than 97 percent, by mass, may exhibit tin whisker growth problems after manufacture. Tin whiskers may occur anytime from a day to years after manufacture and can develop under typical operating conditions, on products that use such materials. Conformal coatings applied over top of a whisker-prone surface will not prevent the formation of tin whiskers. Alloys of tin containing 3 percent or more lead, by mass, have shown to inhibit the growth of tin whiskers. For additional information on this matter, refer to [ASTM-B545](#) (Standard Specification for Electrodeposited Coatings of Tin).

6.11 Supersession data.

6.11.1 Characteristic designation. Resistors formerly identified with characteristic letter "G" under MIL-PRF-39007 are interchangeable and are superseded by resistors of the same style and resistance value under MIL-R-39007D.

6.11.2 Style supersession. The styles of the specification supersede other styles and types as given in table XVIII.

TABLE XVIII. Style supersession.

Style in MIL-R-39007D	Supersede styles in MIL-R-39007A	Superseded styles in MIL-R-39007 ^{1/}	Superseded associate specification in MIL-R-38101 (USAF)
RWR71	RWR71	RWR71	MIL-R-38101/2
RWR74	RWR74	RWR67	MIL-R-38101/16
RWR78	RWR78	RWR68	MIL-R-38101/18
RWR80	RWR80	RWR70	MIL-R-38101/14
RWR81	RWR81		MIL-R-38101/13
RWR84	RWR84		MIL-R-38101/17
RWR89	RWR89	RWR69	MIL-R-38101/15

^{1/} Solderable lead type only.

6.11.3 Method of winding. Resistors classified as having an inductive method of winding (see 1.2.1.2 and 3.5) are equivalent to previously identified resistors with the same PIN and with a solderable terminal (symbol S).

6.12 Retinning leads. If retinning (hot solder dip) of the leads is required see 3.5.6.

6.13 Circuit reactance. If circuit reactance is critical for your application, the contractor should contact the manufacturer for the resistors circuit reactance characteristics.

6.13.1 Reactance resistors. When low reactance resistors are required with values below 10 ohms, the S winding and W winding should be used since these values are low in reactance.

6.13.2 Reactance (applicable to "N" and "Z" terminals and windings only). Effective series inductance and parallel capacitance can be determined using method indicated (see 6.13.2.1). The units should be mounted by their normal mounting means using the fixtures as suggested in the following procedure.

6.13.2.1 Method I. Effective inductance of the resistor should be measured using an HP4194A Impedance/Gain-Phase Analyzer with a 16047D fixture or an HP4192A LF Impedance Analyzer with a 16047A fixture or equivalent. The fixtures should be adjusted so the lead length for all part sizes are minimum. The bridge is zeroed out with the appropriate shorting bar (see figure 3) prior to taking readings and every time the test clip spacing is changed.

MIL-PRF-39007J
w/ Amendment 3

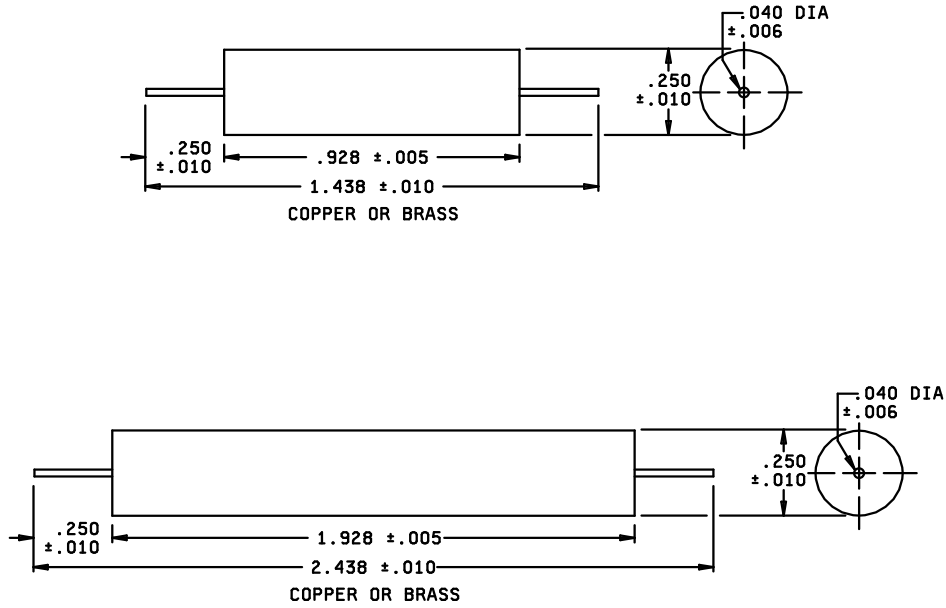

Inches	mm
.005	0.13
.006	0.15
.010	0.25
.040	1.02
.250	6.35
.928	23.57
1.438	36.53
1.928	48.97
2.438	61.93

NOTES:

1. Dimensions are in inches.
2. Metric equivalents are given for general information only.

FIGURE 3. Shorting bar for test fixtures.

MIL-PRF-39007J
w/ Amendment 3

6.14 Caution in handling RWR80 series resistors. The cores of RWR80 series are usually made of beryllium (or beryllium oxide). Dust from the core material of these resistors is hazard if inhaled or deposited in cuts in the skin. Do not machine, abraid, file, cut, etc. without proper safety equipment and procedures.

6.15 Subject term (key word) listing.

Axial leaded
Inductively wound
Non-inductively wound
Precision
Solderable terminals

6.16 Amendment notations. The margins of this specification are marked with asterisks to indicate modifications generated by this amendment. This was done as a convenience only and the Government assumes no liability whatsoever for any inaccuracies in these notations. Bidders and contractors are cautioned to evaluate the requirements of this document based on the entire content irrespective of the marginal notations.

APPENDIX A

PROCEDURE FOR QUALIFICATION INSPECTION

A.1 SCOPE

A.1.1 Scope. This appendix details the procedure for submission of samples, for qualification inspection, of resistors covered by this specification. The procedure for extending qualification of the required sample to other resistors covered by this specification is also outlined herein. This appendix is a mandatory part of the specification. The information contained herein is intended for compliance.

A.2 APPLICABLE DOCUMENTS

This section is not applicable to this appendix.

A.3 SUBMISSION

A.3.1 Product levels. Qualification of the C (nonestablished reliability) level is predicated upon meeting the established reliability qualification requirements for FR level P (see A.4.1). Qualification of the T (space) level is predicted upon meeting the established reliability qualifications requirements for FR level S (see A.4.1). To obtain qualification to the T (space) level, the manufacturer shall also meet the additional requirements for outgassing and the 100 cycle thermal shock test (see A.3.2) as well as being approved by the qualifying activity on the capability to conduct tests and examinations for the space level product (e.g., moisture resistance, destructive physical analysis, production lot formations). The procedure for submitting samples to become qualified to the initial failure level M is specified in A.3.2.

A.3.2 Sample. A sample consisting of 118 highest values and 118 lowest values (down to 0.01 ohm), a coating of enclosed resistors in each style, terminal type, or in each style terminal type (see A.4.2) 1/. At the option of the manufacturer, tolerances of ± 1 percent or ± 5 percent may be submitted in lieu of ± 1 percent. In addition, ten sample units each, of any resistance value, shall be submitted and subjected to the tests of group II and group VIII, respectively. For space level only, 15 lowest values, 15 highest values, to test group IX. If the same coating and core materials are not used, a separate submission shall be furnished for each in each coating and core material for which qualification approval is sought. Four uncoated or unenclosed (2 at the highest and 2 at the lowest resistance value down to 0.10 ohms), shall also be submitted in each style 2/. If enclosures are used in lieu of coating, four enclosures shall be furnished (see A.4.1). After qualification has been granted, no changes shall be made in material, design, or construction without prior notification to the qualifying activity.

A.3.2.1 Additional sample for extension of terminal qualification. When terminal type "S" in a style is submitted, qualification for type "W" shall be granted with the added submission of 32 type "W" resistors (16 of the highest and 16 of the lowest resistance values) to group I, group IA, and group V of table XI. When terminal type "W" in a style is submitted, qualification for type "S" shall be granted with the added submission of 32 (16 of the highest and 16 of the lowest resistance values) samples of type "S" to group I, group IA, and group V (2 additional unenclosed) and group III of table XI. An additional ten samples shall also be subjected to group II alone (see A.4.1).

A.3.2.2 Additional samples for extension of tolerances qualification. When a sample of ± 1 percent tolerance is submitted A.3.1, and where qualification to a lower resistance tolerance is desired (i.e., ± 5 percent, .1 percent), ten additional samples units each of the highest value and lowest or 10 ohms, whichever is higher, in the lowest resistance tolerances for which qualification is sought, shall be submitted and subjected to the inspection of group I, group IA, and group III of table XI (see A.4.1).

- 1/ One additional sample unit of each resistance value shall be submitted to permit substitution for the allowable defect in group IA inspection.
- 2/ The uncoated and unenclosed resistors shall be individually packaged to preclude damage in shipment.

APPENDIX A

A.4 EXTENSION OF QUALIFICATION

A.4.1 Qualification extension. The extension of qualification or resistance values for each style shall range between the highest and lowest values qualified. The extension of qualification between the FR shall be as in table A-I.

Table A-I. Product level extension.

FR level	Will qualify FR level
T	---
S	R, P, M, C
R	P, M, C
P	M, C
M	---
C	---

The extension of qualification between tolerances shall be as in table A-II.

Table A-II. Tolerance extension.

Tolerance	Will qualify
B	D, F
D	F
F(see note)	---

The extension between terminal types shall be as specified [A.3.2.1](#).

NOTE: See [A.3.2.2](#) for extension when additional samples are submitted.

A.4.2 Qualification. Qualification of "N" terminal (solderable, noninductively wound) will qualify the "Z" terminal (weldable, noninductively wound), "S" terminal (solderable, inductively wound), and "W" terminal (weldable, inductively wound) resistors.

A.5. SOLDER DIP (RETINNING) LEADS

A.5.1 Solder dip (retinning) leads. The manufacturer (or their authorized category B or category C distributor) may solder dip/retin the leads of product supplied to this specification provided the solder dip process (see A.5.2) or an equivalent process has been approved by the qualifying activity.

A.5.2 Qualifying activity approval. Approval of the solder dip process will be based on one of the following options:

- a. When the original lead finish qualified was hot solder dip lead finish 52 of [MIL-STD-1276](#) (NOTE: The 200 microinch maximum thickness is not applicable.) The manufacturer shall use the same solder dip process for retinning as is used in the original manufacture of the product.
- b. When the lead originally qualified was not hot solder dip lead finish 52 of [MIL-STD-1276](#), as prescribed in A.5.2a, approval for the process to be used for solder dip shall be based on the following test procedure:
 - (1) Thirty samples of any resistance value for each style and lead finish are subjected to the manufacturer's solder dip process. Following the solder dip process, the resistors are subjected to the dc resistance test (and other group A electricals). No defects are allowed.
 - (2) Ten of the 30 samples are then subjected to the solderability test. No defects are allowed.
 - (3) The remaining 20 samples are subjected to the resistance to solder heat test followed by the moisture resistance test. No defects are allowed.

APPENDIX A

A.5.3 Solder dip/retinning options. The manufacturer (or authorized category B or category C distributor) may solder dip/retin as follows:

- a. After the 100 percent group A screening tests: Following the solder dip/retinning process, the dc resistance measurement shall be repeated on 100 percent of the lot. (NOTE: The manufacturer may solder dip/retin prior to the 100 percent electrical measurements of the group A, subgroup 1 tests.) The PDA for the electrical measurements shall be as for the subgroup 1 tests.
- b. As a corrective action: If the lot fails the group A solderability test, the lot may be retinned no more than two times. The lot after retinning shall be 100 percent screened for dc resistance, any parts failing (not exceeding the PDA for group A, subgroup 1 electricals, (see [4.6.3.2.1](#)) these screens shall not be supplied to this specification. If electrical failures are detected after the second retinning operation exceeding three percent of the lot, the lot shall not be supplied to this specification.
- c. After the group A inspection has been completed: Following the solder dip/retinning process, dc resistance shall be repeated on 100 percent of the lot. The PDA for the electrical measurements shall be as for the subgroup 1 tests. Following these tests, the manufacturer shall submit the lot to the group A solderability test as specified in [4.8.4](#).

APPENDIX B

PROCEDURES FOR DESTRUCTIVE PHYSICAL ANALYSIS (DPA)
(SPACE LEVEL ONLY)

B.1 SCOPE

B.1.1 Scope. This appendix provides the methods and detailed requirements for DPA of wire-wound resistors (see [figure B-1](#)). This appendix is a mandatory part of the specification. The information contained herein is intended for compliance.

B.2 APPLICABLE DOCUMENTS

This section is not applicable to this appendix.

B.3 EQUIPMENT AND PROCEDURES

B.3.1 Equipment.

B.3.1.1 Sample preparation. A mechanical or chemical process shall be use to remove the outer insulating materials. This process shall cause minimal damage to the internal resistor structure. When resistors contain beryllium-oxide cores, there shall be no machining, grinding, filling, or polishing performed on the cores. Beryllium-oxide dust is highly toxic.

B.3.1.2 Optical equipment. A binocular microscope with a minimum capability of 30x magnification and an integral light source or fiber optic light ring shall be used.

B.3.2 Resistor, fixed, wire-wound, style RWR81, RWR84, and RWR89.

B.3.2.1 Method.

B.3.2.2 External visual. Examine resistors at 30x minimum magnification, and examine terminals, leads, marking, general dimensions, and appearance for any evidence of defective workmanship.

B.4 SAMPLE PREPARATION

B.4.1 Conformably coated resistors. Conformal coating can be mechanically or chemically removed. When mechanical means are employed, care must be taken not to induce any rejectable defect on the resistor itself (see [B.3.1.1](#) when core is beryllium-oxide). When chemically stripping the coating, use a process and material which dissolves the coating and exposes, but not attacks, the wire, core, end terminations, leads, and welded connections, and which does not discolor or stain any surface. As required, perform scanning electron microscope (SEM) inspection and check for corrosion.

B.5 DATA RECORDS

B.5.1 Data records. DPA findings that deviate from configuration and other requirements shall be documented as defects.

APPENDIX B

B.5.2 Evaluation criteria. When the DPA is conducted as a lot conformance test, the production lot shall be rejected if one or more of the DPA samples exhibit any of the defects listed below. The manufacturer has the option, with qualifying activity approval, to use DPA evaluation criteria tailored to the individual product. The DPA evaluation criteria shall be documented in the [MIL-STD-790](#) program. All exposed inner surfaces of each resistor shall be examined at 30x minimum magnification for the following characteristics:

- a. End cap misalignment greater than 5 degrees.
- b. End cap showing corrosion, lifted, or missing plating.
- c. Weld splatter at lead-to-end cap termination, or cracks in weld joint.
- d. Cracked, split, or holes (from welding operation) on end caps.
- e. Sudden kinks, bends, or sharp distortion on the resistance wire that reduces the wire diameter to 5/6ths or less of the initial value.
- f. Loose windings on active portion of the resistor.
- g. Wire not secure at weld on end cap.
- h. Number of wire turns different between samples having similar resistance values, up to 5 percent or one turn, whichever is greater.
- i. Space between wires turns more than five times the wire diameter except for values less than 1 ohm, or space between turns of less than the wire diameter except for high-value resistors using insulated wires.
- j. Cracks, spalls or surface holes on the core that exceed .025 inch (0.06 mm) in the greatest dimension.

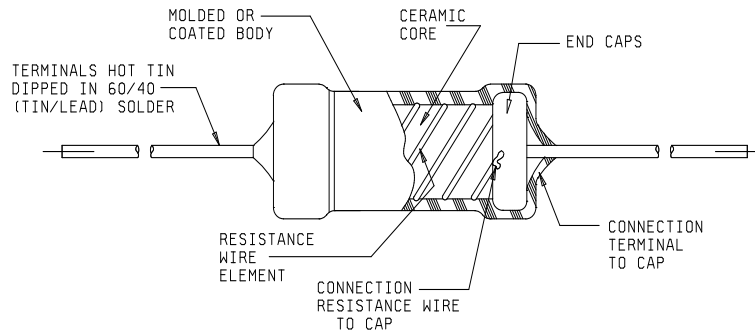

FIGURE B-1. Typical wire-wound resistor, RWR style.

APPENDIX C

RADIOGRAPHIC INSPECTION
(SPACE LEVEL ONLY)

C.1 SCOPE

C.1.1 Scope. This appendix specifies procedures and practices necessary for radiographic inspection of wire-wound resistors during group A inspection. This appendix is a mandatory part of the specification. The information contained herein is intended for compliance only.

C.1.2 Facilities. Radiographs of the resistors may be made by the resistor manufacturer or a suitable independent laboratory. In case, facilities, equipment, personnel, and techniques shall be in accordance with the requirements specified herein.

C.1.3 Responsibility for inspection. The resistor manufacturer shall perform the inspection of the radiographic films and acceptance/rejection of the resistors.

C.2 APPLICABLE DOCUMENTS

This section is not applicable to this document.

C.3 EQUIPMENT

C.3.1 Dimensions. The dimensional values upon which these requirements are based were developed using the U.S. system. The metric equivalents are obtained by direct conversion based upon 1 inch = 25.4 mm. Where such equivalents do not correspond to a standard metric size, the closest standardized metric equivalent size may be used.

C.3.2 Radiography. The X-ray equipment shall have sufficient voltage range to produce radiographs in accordance with this document. The equipment shall have a focal spot of .14 inch (3.5 mm) or less and shall maintain a sharply defined image at a focal film distance of 30 inches to 60 inches (76.20 centimeters to 152.40 centimeters).

C.3.3 Exposure factors. The X-ray exposure factors shall be selected to achieve maximum image detail within the sensitivity requirements. The film shall be exposed in accordance with the following requirements:

- a. X-ray voltage: Lowest voltage possible.
- b. H and D film density: 1.5 to 3.0.
- c. Milliampere and time settings: Adjusted, as necessary, to obtain satisfactory exposure.

C.3.4 Film. The X-ray film shall be single emulsion and of a grade defined as very fine grain.

C.3.4.1 Sensitivity. X-ray film and equipment shall be capable of detecting metallic particles with a major dimension of .004 inch or greater.

C.3.4.2 Exposure. Exposure factors such as KVP, current, and time shall be compatible with the sensitivity requirements of C.3.4.1.

MIL-PRF-39007J
w/ Amendment 3

APPENDIX C

C.3.4.3 **Film density.** The X-ray equipment and processing techniques shall be capable of producing H and D film density of 1.5 to 3.0 in accordance with the American Standard Printing density, type P.

C.3.4.4 **Film dimensions.** Radiographic film shall not exceed 14 inches (35.56 centimeters) in width and 17 inches (43.18 centimeters) in length.

C.3.4.5 **Processing.** The exposed X-ray film shall be processed in such a manner that the film shall be free of processing defects, i.e., fingerprints, chemical spots, blemishes, etc.

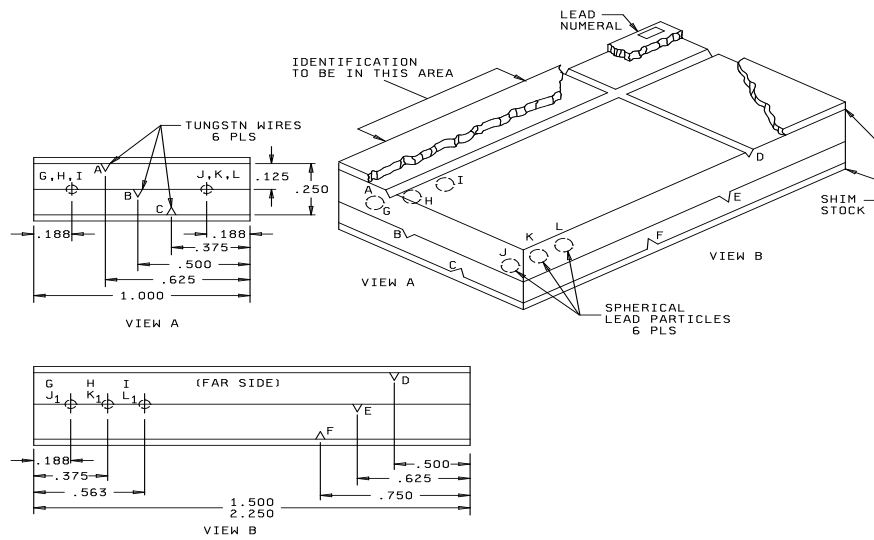

Inches	mm	Inches	mm
.125	3.18	.625	15.88
.188	4.78	.675	17.14
.250	6.35	.750	19.05
.375	9.52	1.000	25.40
.500	12.70	1.500	38.10
.563	14.30	2.250	57.15

FIGURE C-1. Penetrameter.

MIL-PRF-39007J
w/ Amendment 3

APPENDIX C

Tungsten wire diameters						Lead particle diameters						Steel shim stock
A	B	C	D	E	F	G	H	I	J	K	L	
.002 (.05)	.001 (.03)	.0005 (.013)	.0005 (.013)	.001 (.03)	.002 (.05)	.015 (.38)	.010 (.25)	.008 (.20)	.006 (.15)	.004 (.10)	.002 (.05)	None
												.002 (.05)
												.005 (.13)
↓	↓	↓	↓	↓	↓							.007 (.18)
.003 (.08)	.002 (.05)	.001 (.03)	.001 (.03)	.002 (.05)	.003 (.08)							.010 (.25)
.003 (.08)	.002 (.05)	.001 (.03)	.001 (.03)	.002 (.05)	.003 (.08)							.015 (.38)
.005 (.13)	.003 (.08)	.002 (.05)	.002 (.05)	.003 (.08)	.005 (.13)							.025 (.64)
.005 (.13)	.003 (.08)	.002 (.05)	.002 (.05)	.003 (.08)	.005 (.13)	↓	↓	↓	↓	↓	↓	.035 (.89)

NOTES:

1. Dimensions are in inches.
2. Metric equivalents are given for general information only.
3. Wires to be tungsten, shim stock to be carbon steel, particles to be lead. Center section to be .125 inch (3.18 mm) layers of clear acrylic plastic, bonded with clear plastic cement of low X-ray density. Fasteners may be used within .250 inch (6.35 mm) or less from each corner, but shall not interfere with end of use of the penetrometer. Bottom surfaces shall be flush.
4. All dimensions shown are ± 0.005 inch (0.13 mm), except wires and shim stock, which shall be within standard mill tolerances, and lead particles which shall be ± 0.0002 inch (0.005 mm). Groove details are not critical except that the wire must be embedded flush or below surface of plastic and centered at location shown. Particle holes size are not critical, and should not exceed .031 inch (0.79 mm) in diameter and depth. Holes must be centered as shown (± 0.005 inch (0.13 mm)).
5. Additional layers of shim stock may be used as necessary.
6. Identification marking shall be permanent and legible. Location and size of characters is not critical but shall not interfere with, or obscure, the radiographic image details.

FIGURE C-1. Penetrometer - Continued.

APPENDIX C

C.3.4.6 Film identification. Each radiographic film shall be identified with the following information:

- a. Part manufacturer's name.
- b. PIN (as marked on part).
- c. Part cross reference.
- d. Date or lot code (as marked on part).
- e. View number.
- f. X-ray laboratory name.
- g. Penetrameter image.
- h. Penetrameter number (see [figure C-1](#)).

C.3.5 Penetrameters. Penetrameters shall be employed in all radiographic testing and shall be as specified on [figure C-1](#). The penetrameter image shall be used to determine radiographic quality and shall meet the following requirements:

- a. Penetrameter wires shall be visible on each radiograph.
- b. Penetrameters shall be selected to give a film density within +10 percent of the density of the area of immediate interest.
- c. Penetrameters shall be placed on diagonal corners on the source side of the film. The plane of the penetrameters shall be normal to the radiation film. The plane of the penetrameters shall be normal to the radiation beam. When 35-m film strip is used, the penetrameter shall be placed in a position normally occupied by a part, and a penetrameter image shall be made (exposed) for every 50 parts or 17 inches (43.18 centimeters) of film, whichever is more convenient.
- d. Distortion of any penetrameter shall not exceed 10 percent.
- e. The spacing between wires of a penetrameter shall not be distorted by more than 10 percent. The percentage of distortion as used in this standard is defined as follows:

Percentage distortion = $[(S_0 - S_1)/S_0] \times 100$, where S_0 = actual wire spacing, and S_1 = wire spacing as it appears on the X-ray film.

C.3.6 Fixtures. Suitable fixtures shall be used for mounting the electronic parts during the X-ray operation.

C.3.6.1 Mounting of parts. The resistors may be mounted in any type of fixture, provided that any metallic portion of the fixture is not between the body of the resistor and the film.

C.3.6.2 Identification of resistors. Each resistor shall be traceable from its position on the fixture to its corresponding image on the film until completion of film inspection and identification of any resistor with rejectable defects.

C.3.7 Inspection and examination of radiographs. Inspection of radiographs shall be conducted by the device manufacturer. Each radiograph shall be examined, utilizing the equipment specified herein. The radiographs shall be inspected to determine that each resistor conforms to the requirements of this document.

APPENDIX C

C.3.7.1 Viewing equipment. The radiograph shall be examined on a suitable illuminator with variable intensity, or on a viewer suitable for radiographic inspection of projection type viewing equipment.

C.3.7.2 Magnification. A magnification of 10x power minimum shall be used for radiographic examination.

C.4 REPORTS AND RECORDS

C.4.1 Report of inspection. Unless otherwise specified by the contractor, the testing activity shall furnish inspection reports signed by an authorized representative of the testing activity. The reports shall give the results of the radiographic inspection and shall list the part number, the number of parts inspected, the number of parts rejected, and the date of the test.

C.4.2 Records of inspection. A complete record of details of inspection shall be kept by the manufacturer or testing laboratory. The record shall list the voltage potentials and currents used in the radiographic process, the time of exposure, the distance of the source of radiation from the surface of the part, the distance of the film from the same surface, the approximate angle between the central beam of radiation and the film, the screens and filters used, the size of the focal spot, the time of development of the film, and the PIN and lot or date code of the resistors.

C.4.3 Records of radiographs. Each radiograph shall carry a radiograph inspection serial number or code letters to identify the radiograph with the parts examined shown in the radiograph. One complete set of radiographs shall be kept by the manufacture for a period of 3 years, minimum.

C.5 PERSONNEL

C.5.1 Radiographer. Personnel engaged in radiographic processing shall be familiar with the requirements of this standard and with all applicable documentation controlling radiographic quality of parts and material being inspected. They shall be certified by their employer to be capable of producing radiographs which meet the requirements of all applicable documentation.

C.5.2 Radiographic interpreters. Personnel engaged in the interpretation of radiographs shall be familiar with the requirements of this standard and with all applicable documentation controlling radiographic quality of parts and materials being inspected. They shall be certified by their employer to be capable of evaluating radiographs to determine conformance of parts and materials to the requirements of all applicable documentation.

C.5.3 Vision. The minimum vision requirements for visual acuity of personnel inspecting film shall be as follows:

- a. Distant vision shall equal to 20/30 in at least one eye, either corrected or uncorrected.
- b. Near vision shall be such that the individual can read Jaeger type No. 2 at a distance of 16 inches (40.64 centimeters) either corrected or uncorrected.

C.5.4 Vision tests. Vision tests shall be performed by an oculist, optometrist, or by other professionally recognized personnel. One year from the effective due date of original certification, and each year thereafter, certified personnel shall be required to pass the vision tests specified herein.

APPENDIX C

C.6 ACCEPT REJECT CRITERIA

C.6.1 Accept reject criteria. Any defects shown on figure C-2.

C.6.1.1 End caps. See 3.5.4.

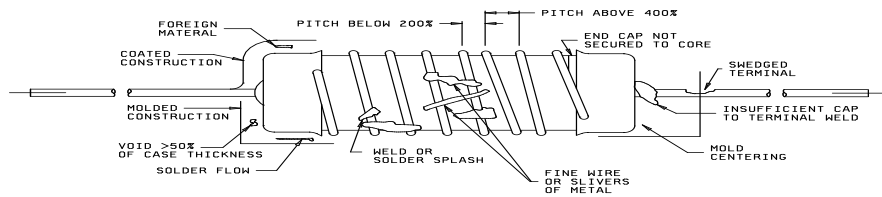

FIGURE C-2. Radiography visual reject criteria.

MIL-PRF-39007J
w/ Amendment 3

Custodians:
Army - CR
Navy - EC
Air Force - 85
NASA - NA

Preparing activity:
Army - CR

Agent:
DLA - CC

Review activities:
Army - AR, MI
Navy - AS, CG, MC, OS
Air Force - 19, 99
Other - MDA

(Project 5905-2017-071)

NOTE: The activities listed above were interested in this document as of the date of this document. Since organizations and responsibilities can change, you should verify the currency of the information above using the ASSIST Online database at <https://assist.dla.mil>.