

[INCH-POUND]
A-A-55534/8C
28 June 2018
SUPERSEDING
A-A-55534/8B
24 April 2003

COMMERCIAL ITEM DESCRIPTION

RESISTOR, FIXED, CHIP, VERY LOW VALUES (POWER TYPE), STYLE VLV2512

The General Services Administration has authorized the use of this commercial item description (CID) for all federal agencies.

Inactive for new design after 28 June 2018.
For replacement purposes only. For new design use
DLA Land and Maritime drawing [06011](#).

- * The complete requirements for procuring of a fixed, wirewound or metal element resistor described herein shall consist of this document and the issue in effect of [A-A-55534](#).
- * CLASSIFICATION OR PART IDENTIFICATION NUMBER (PIN). This commercial item description (CID) specification sheet uses a classification system which is included in the PIN as shown in the following example (see [NOTES](#)).

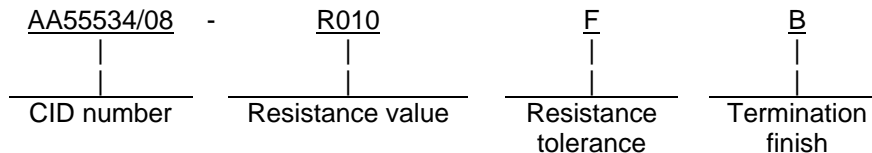

NOTE: This PIN has been derived in accordance with [A-A-55534](#).

SALIENT CHARACTERISTICS.

- * Interface and physical dimensions. Resistors supplied to this CID specification sheet shall meet the interface and physical dimensions as specified herein (see [figure 1](#)).

Resistance value. The resistance value shall be 0.005 ohm to 0.1 ohm.

Resistance tolerance. This style resistor is available in resistance tolerances F, H, and J (± 1 percent, ± 3 percent, and ± 5 percent respectively).

Termination finish. The termination finish shall be identified by a single letter, B for tin/lead (Sn/Pb) (3 percent lead minimum) or T (Sn) (100 percent tin).

AMSC N/A

FSC 5905



A-A-55534/8C

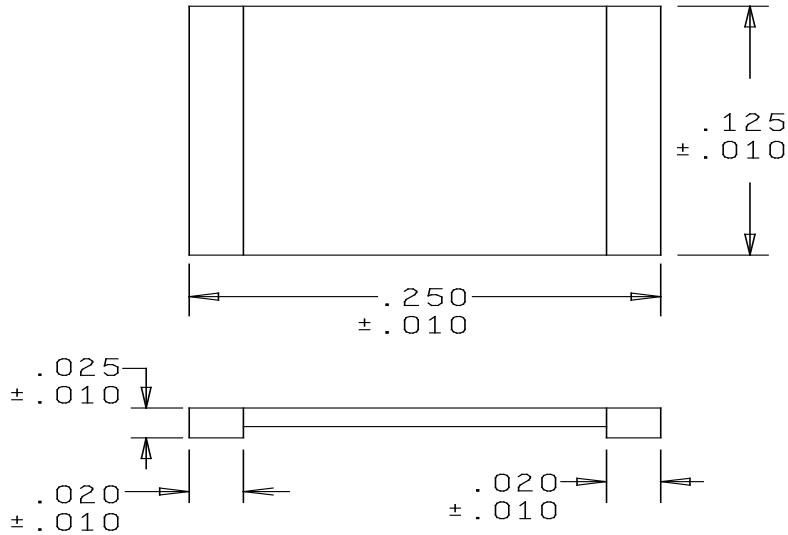

Inches	mm	Inches	mm
0.010	0.25	0.125	3.18
0.020	0.51	0.250	6.35
0.025	0.64		

NOTES:

1. Dimensions are in inches.
2. Metric equivalents are given for general information only.
3. The picturization of the style above is given as representative of the envelope of the item. Slight deviations from the outline shown, which are contained within the envelope and do not alter the functional aspects of the device, are acceptable.

FIGURE 1. Resistors, fixed, chip, very low values (style VLV2512).

- * Power rating. The power rating shall be 0.25 watt at +70°C. The power rating shall be linearly derated to zero at +150°C or +175°C (see [Commercial products](#)).
- * Temperature coefficient. The temperature coefficient of resistance shall not exceed ±400ppm/°C from -55°C to +150°C or +175°C.
- * Marking. Resistors supplied to this CID specification sheet shall be marked with the manufacturer's standard commercial PIN. Marking of individual small devices (e.g. chips) is not required but is permitted; however, each unit pack supplied to this CID shall be marked with the commercial item description PIN.

NOTES.

- * PIN. The PIN should be used for Government purposes to buy commercial products to this CID specification sheet. See [Classification](#) section for PIN format.

Source of documents.

Commercial Item Description

[A-A-55534](#) - Resistor, Fixed, Power Type (Very Low Resistance Values), General Requirements For

- * (Copies of commercial item descriptions are available online at <http://quicksearch.dla.mil>.)
- * Commercial products. As part of the market analysis and research effort, this CID specification sheet was coordinated with the following manufacturers of commercial products. At the time of CID specification sheet preparation and coordination, these manufacturers were known to have commercial products that would meet the requirements of this CID specification sheet. (NOTE: This information should not be considered as a list of approved manufacturers or be used to restrict procurement to only the manufacturers shown.)

MFR's CAGE	MFR's name and address
91637	Dale Electronics, Incorporated 1122 23 rd St. Columbus, NE 68601-0609 Dale Israel, Ltd. Emek-Sara Industrial Zone 3, Ha'Kotzer str. Be'er Sheva, Israel 84 874 Phone: 402-563-6866 Fax: 402-563-6296 Email: business-americas@vishay.com Website: www.vishay.com
57027	TT Electronics / IRC 4222 S. Staples St. Corpus Christi, TX 78411-2702 Phone: 972-323-2200 Email: http://www.ttelectronics.com/ Website: www.ttelectronics.com

- * Part number (P/N) supersession data. This CID specification sheet PINs supersedes the MFGR's as shown. This information is being provided to assist in reducing proliferation in the Government inventory system.

A-A-55534/8C

CID PIN	MFGR's CAGE	MFGR's P/N <u>1/</u>	MFGR's SALIENT CHARACTERISTICS
AA55534/08-*****	91637	WSL 2512	Resistance value 0.005 ohm to 0.1 ohm, resistance tolerance F, H, and J, temp coefficient 75 ppm, derated to zero at 175°C.
AA55534/08-*****	57027	LR2512	Res. value 0.050 ohm to 0.100 ohm, temp coefficient ±100ppm; res. value 0.020 ohm to 0.049 ohm, temp coefficient ±300ppm; res. value 0.010 ohm to 0.019 ohm, temp coefficient ±400ppm; derated to zero at 150°C, res. Tol. F, H, and J.

1/ The manufacturers P/N shall not be used for acquisition to the requirements of this CID specification sheet. At the time of preparation of this CID specification sheet, the aforementioned commercial products were reviewed and could be replaced by the CID PIN shown. For actual part marking requirements, see the marking paragraph of [A-A-55534](#).

- * National Stock Number. This section is not applicable to this CID.
- * Changes from previous issue. The margins of this CID specification sheet are marked with asterisks to indicate where changes from the previous issue were made. This was done as a convenience only and the Government assumes no liability whatsoever for any inaccuracies in these notations. Bidders and contractors are cautioned to evaluate the requirements of this document based on the entire content irrespective of the marginal notations and relationship to the last previous issue.

MILITARY INTERESTS:

Custodian
Navy - EC
DLA-CC

CIVIL AGENCY COORDINATING ACTIVITY:

GSA - FAS

Preparing Activity:
DLA-CC

Project 5905-2018-029

NOTE: The activities listed above were interested in this document as of the date of this document. Since organizations and responsibilities can change, you should verify the currency of the information above using the ASSIST Online database at <https://assist.dla.mil>.